



PARTS CATALOGUE

YZ250FE (1SM1) CANADA

YZ250F (1SM2) EUROPE

YZ250F (1SM3) JAPAN

YZ250FE (1SM4) OCEANIA, SOUTH AFRICA

YZ250FE/YZ250F
PARTS CATALOGUE
©2013 by Yamaha Motor Co., Ltd.
1st edition, September 2013
All rights reserved.
Any reprinting or unauthorized use
without the written permission of
Yamaha Motor Co., Ltd.
is expressly prohibited.
Printed in Japan.

FOREWORD

This Parts Catalogue is related to the parts for the model(s) on the cover page. When you are ordering replacement parts, please refer to this Parts Catalogue and quote both part numbers and part names correctly.

1. Modifications or additions which have been made after the issue of the Parts Catalogue will be announced in the Parts News.

It is advisable that you make the necessary corrections to the Parts Catalogue according to the Parts News.

2. Abbreviations

The following abbreviations are used in this Parts Catalogue.

“UR” Use specified parts number.

“UN” Use as many as needed.

“AP” Alternate Parts

“LM” Locally Made (Parts need to be ordered locally)

“F#” Frame No. (Applicable machine No.)

“O/S” Over Size

3. The number of components for assembly

- Parts, which are to be supplied in an assembly, are listed with a dot (.) in front of the part name as shown below.
- The numeral appearing to the right of each component part indicates the quantity of parts for each assembly unit.

PART NO.	DESCRIPTION	Q'TY	REMARKS
2F5-83310-60	FRONT FLASHER LIGHT ASSY	2	
115-83311-60	.BULB (6V-18W)	1	

4. Applicable colours of graphics are represented in the “REMARKS” as shown below.

PART NO.	DESCRIPTION	Q'TY	REMARKS
2N4-24110-00-X5	FUEL TANK COMP.	2	MXR
3J1-24240-10	.GRAPHIC, FUEL TANK	1	FOR MXR

5. Note that the illustrations for reference in finding parts numbers are not to be used for assembling. When assembling, please use the applicable service manual.

6. The asterisk (*) before a reference number indicates modified items after the first edition.

MODEL LABEL

(1) A label called "Model Label" is affixed in the location as indicated in (3) below. When using this parts catalogue, please be sure to cross-reference the "model code – production code No." in the catalogue with the "model code – production code No." indicated on the Model Label affixed onto the product concerned.

(2) "Model Label" Indication

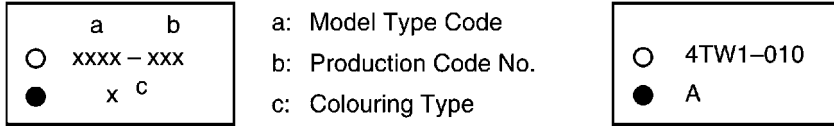

(3) Model Label Affixing Location

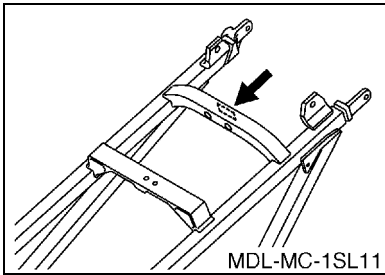

(4) Colouring Information

Model Code	Colouring Type Code	Colour Code	Colour Name	Abbreviation
1SM1	A	0583	DEEP PURPLISH BLUE SOLID E	DPBSE
	B	0206	PURPLISH WHITE SOLID 1	PWS1
1SM2	A	0583	DEEP PURPLISH BLUE SOLID E	DPBSE
	B	0206	PURPLISH WHITE SOLID 1	PWS1
1SM3	A	0583	DEEP PURPLISH BLUE SOLID E	DPBSE
1SM4	A	0583	DEEP PURPLISH BLUE SOLID E	DPBSE
	B	0206	PURPLISH WHITE SOLID 1	PWS1

(5) Model Code – Production Code Number of Model Listed in This Parts Catalogue

Model Code	Production Code No.	Country (destination)	Model Code	Production Code No.	Country (destination)
1SM1	020	CANADA	1SM4	010	AUSTRALIA
1SM2	010	AUSTRIA			NEW ZEALAND
		BELGIUM			SOUTH AFRICA
		CYPRUS			
		CZECHO			
		DENMARK			
		FINLAND			
		FRANCE			
		GERMANY			
		GREECE			
		HUNGARY			
		IRELAND			
		ITALY			
		NETHERLANDS			
		NORWAY			
		POLAND			
		PORTUGAL			
		SLOVAK			
SLOVENIA					
SPAIN					
SWEDEN					
SWITZERLAND					
TURKEY					
UNITED KINGDOM					
1SM3	010	JAPAN			

CONTENTS

ENGINE

CYLINDER	1
CRANKSHAFT & PISTON	3
VALVE	4
CAMSHAFT & CHAIN	6
WATER PUMP	7
RADIATOR & HOSE	8
OIL PUMP	9
OIL CLEANER	10
INTAKE	11
INTAKE 2	13
EXHAUST	14
CRANKCASE	16
CRANKCASE COVER 1	17
STARTER	18
CLUTCH	19
TRANSMISSION	21
SHIFT CAM & FORK	23
SHIFT SHAFT	24

CHASSIS

FRAME	25
FENDER	27
SIDE COVER	28
REAR ARM	30
REAR SUSPENSION	32
STEERING	34
FRONT FORK	35
FUEL TANK	38
SEAT	39
FRONT WHEEL	40
FRONT BRAKE CALIPER	41
REAR WHEEL	42
REAR BRAKE CALIPER	44
STEERING HANDLE & CABLE	45
FRONT MASTER CYLINDER	46
STAND & FOOTREST	47
REAR MASTER CYLINDER	48
GENERATOR	49
HANDLE SWITCH & LEVER	50
ELECTRICAL 1	51
ALTERNATE FOR CHASSIS	53

INDEX

NUMERICAL INDEX	54
-----------------------	----

FIG. 1 CYLINDER

REF. NO.	PART NO.	DESCRIPTION	1SM1	1SM2	1SM3	1SM4	REMARKS
1	1SM-11101-09	CYLINDER HEAD ASSY	1	1	1	1	
2	5TA-11134-10	.GUIDE, VALVE 2	2	2	2	2	
3	3D7-11133-10	.GUIDE, VALVE 1	2	2	2	2	
4	91808-16023	.PIN, DOWEL	4	4	4	4	
5	90105-06027	.BOLT, FLANGE	8	8	8	8	
6	90340-12007	.PLUG, STRAIGHT SCREW	1	1	1	1	
7	95022-06010	BOLT, FLANGE	1	1	1	1	
8	90430-06014	GASKET	1	1	1	1	
9	95612-08620	BOLT, STUD	2	2	2	2	
10	94701-00434	PLUG, SPARK (NGK LMAR8G)	1	1		1	
	94703-00434	PLUG, SPARK (NGK LMAR8G)			1		
11	1SM-11181-00	GASKET, CYLINDER HEAD 1	1	1	1	1	
12	93612-16254	PIN, DOWEL	2	2	2	2	
13	90105-09004	BOLT, FLANGE	4	4	4	4	
14	90201-096J9	WASHER, PLATE	4	4	4	4	
15	90116-06037	BOLT, STUD	2	2	2	2	
16	95702-06500	NUT, FLANGE	2	2	2	2	
17	1SM-11190-09	COVER, CYLINDER HEAD 1	1	1	1	1	
18	5BE-12241-00	GUIDE, STOPPER 2	1	1	1	1	
19	1SM-11166-00	PIPE, BREATHER 1	1	1	1	1	
20	90467-140A4	CLIP	1	1	1	1	
21	5UM-1119E-00	BOLT, COVER HEAD	2	2	2	2	
22	1SM-11194-00	GASKET, HEAD COVER 2	1	1	1	1	
23	1SM-11193-00	GASKET, HEAD COVER 1	1	1	1	1	
24	1SM-11311-00	CYLINDER 1	1	1	1	1	
25	1SM-11351-00	GASKET, CYLINDER	1	1	1	1	
26	93612-16254	PIN, DOWEL	2	2	2	2	

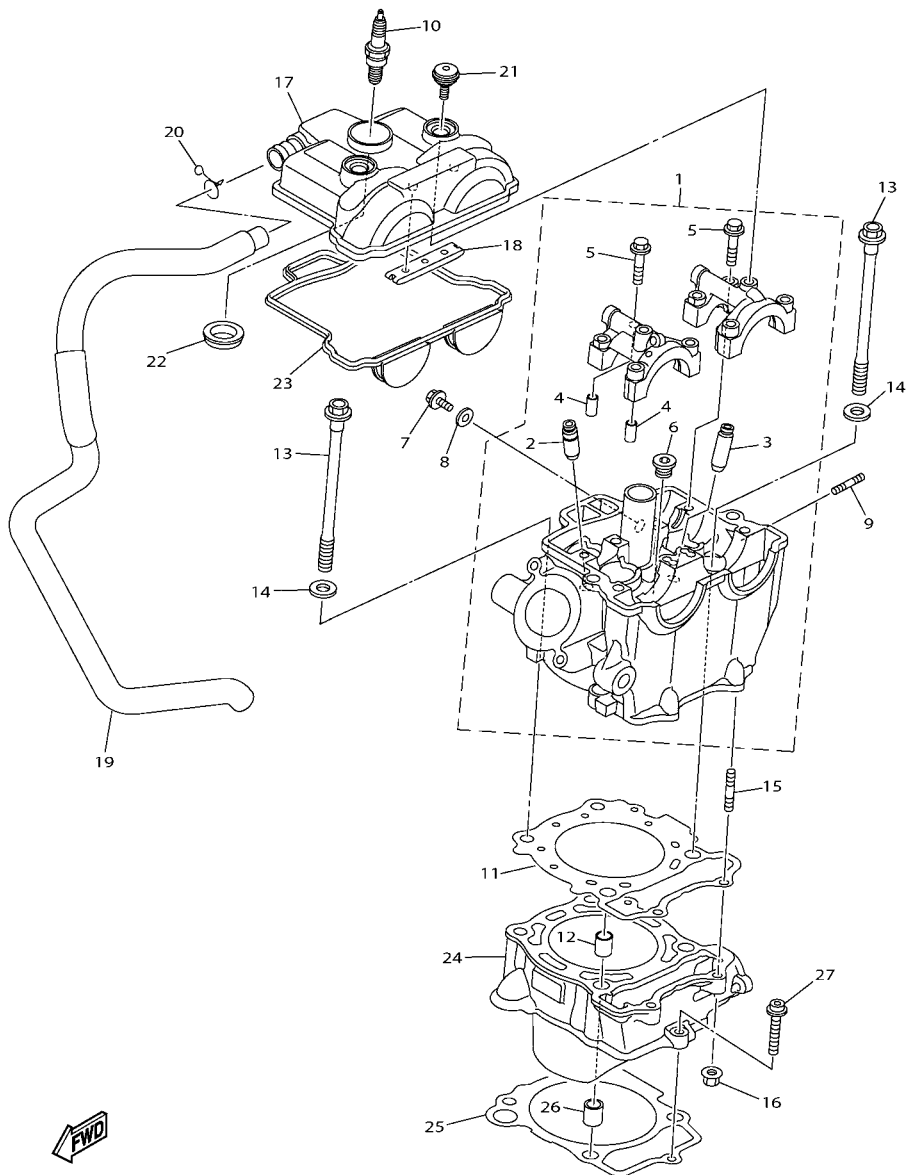

1SM1110-N010

FIG. 2 CRANKSHAFT & PISTON

REF. NO.	PART NO.	DESCRIPTION	1SM1	1SM2	1SM3	1SM4	REMARKS
1	1SM-11400-00	CRANKSHAFT ASSY	1	1	1	1	
2	1SM-11412-00	.CRANK 1	1	1	1	1	
3	1SM-11422-00	.CRANK 2	1	1	1	1	
4	1SM-11681-00	.PIN, CRANK 1	1	1	1	1	
5	93310-63096	.BEARING	1	1	1	1	
6	1SM-11651-00	.ROD, CONNECTING	1	1	1	1	
7	93306-20648	BEARING	2	2	2	2	
8	1SM-11536-00	GEAR, DRIVE (30T)	1	1	1	1	
9	1SM-11455-00	SHAFT 1	1	1	1	1	
10	93306-20351	BEARING	2	2	2	2	
11	90387-175R2	COLLAR	1	1	1	1	
12	1SM-11531-00	GEAR, BALANCE WEIGHT	1	1	1	1	
13	1SM-11454-00	WEIGHT 1	1	1	1	1	
14	90149-06083	SCREW	2	2	2	2	
15	90208-14033	WASHER, CONICAL SPRING	1	1	1	1	
16	90170-14171	NUT	1	1	1	1	
17	1SM-11464-00	WEIGHT 2	1	1	1	1	
18	90208-10001	WASHER, CONICAL SPRING	1	1	1	1	
19	90170-10405	NUT	1	1	1	1	
20	1SM-116A0-00	PISTON ASSY			1	1	
21	1SM-11631-00	.PISTON (STD)			1	1	
22	1SM-11603-00	.PISTON RING SET (STD)			1	1	
23	1SM-11633-00	.PIN, PISTON			1	1	
24	93450-17129	.CIRCLIP			2	2	
25	90280-03006	KEY, WOODRUFF	1	1	1	1	

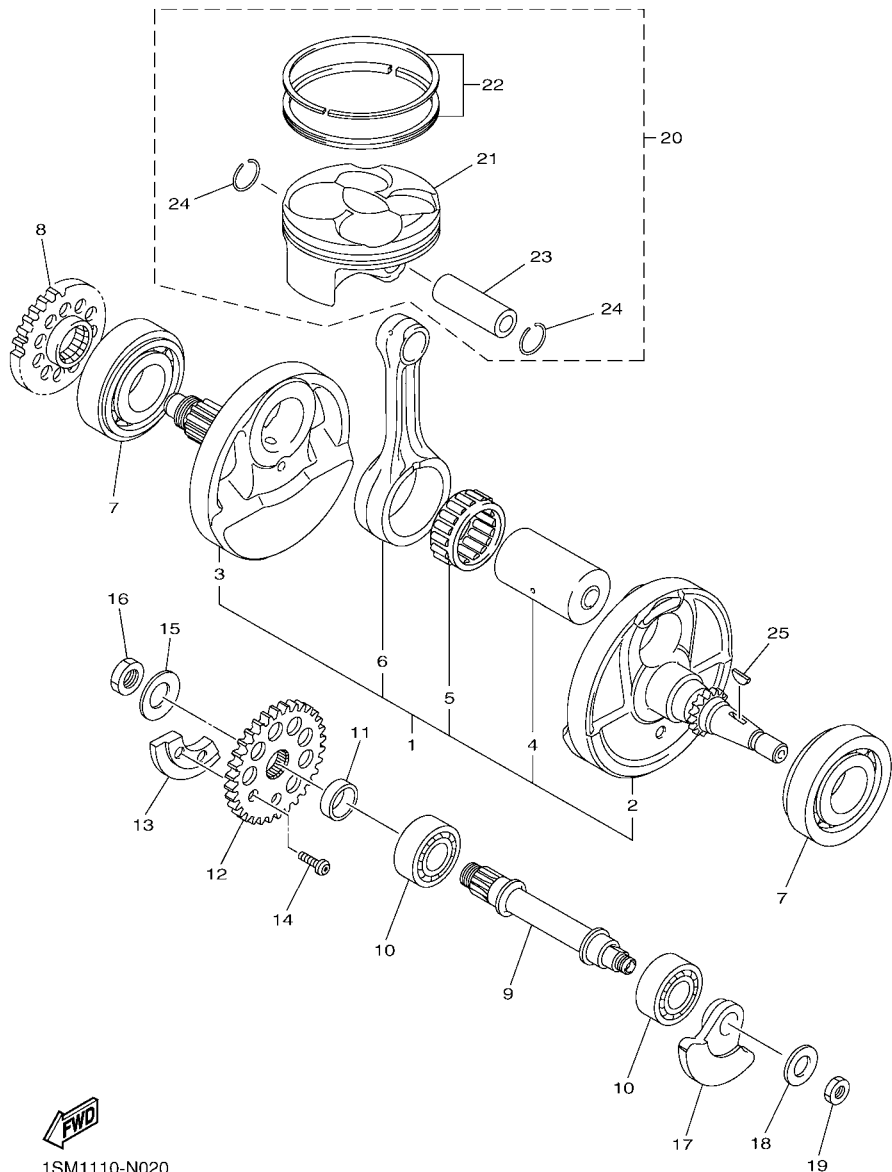

1SM1110-N020

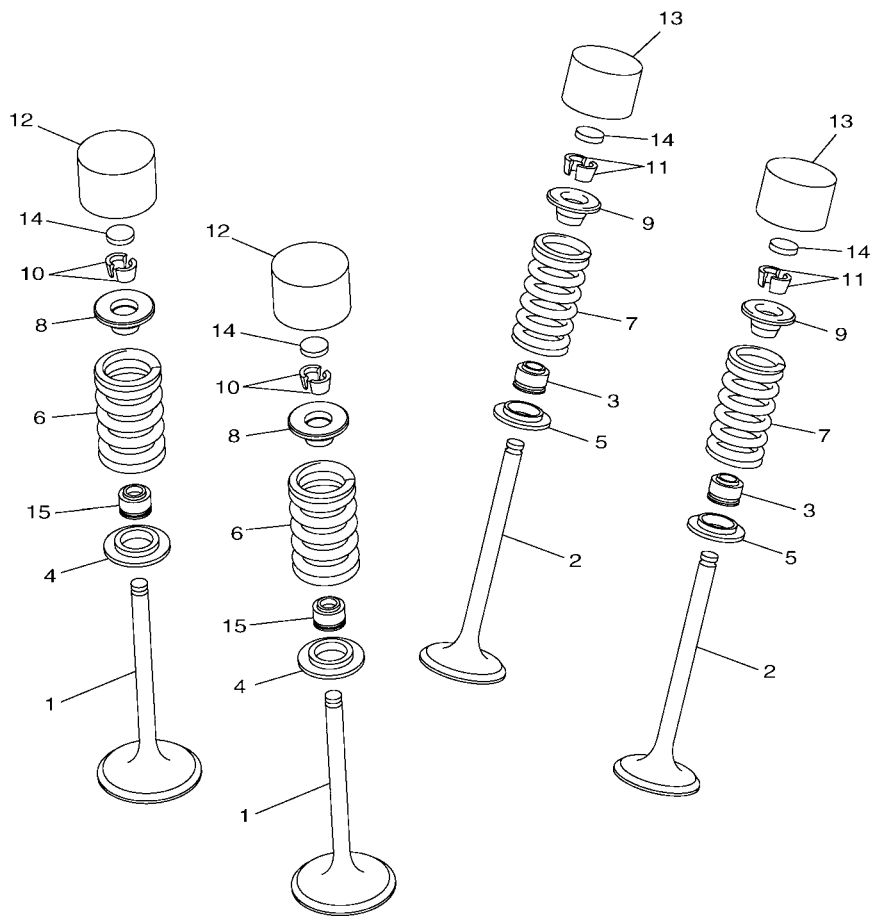

1SM1110-N030

FIG. 3 VALVE

REF. NO.	PART NO.	DESCRIPTION	1SM1	1SM2	1SM3	1SM4	REMARKS
1	1SM-12111-00	VALVE, INTAKE	2	2	2	2	
2	1SM-12121-00	VALVE, EXHAUST	2	2	2	2	
3	4TE-12119-00	SEAL, VALVE STEM	2	2	2	2	
4	1SM-12116-00	SEAT, VALVE SPRING	2	2	2	2	
5	1SM-12126-00	SEAT, VALVE SPRING 2	2	2	2	2	
6	1SM-12113-00	SPRING, VALVE INNER	2	2	2	2	
7	1SM-12114-00	SPRING, VALVE OUTER	2	2	2	2	
8	1SM-12117-00	RETAINER, VALVE SPRING	2	2	2	2	
9	1SM-12127-00	RETAINER, VALVE SPRING	2	2	2	2	
10	1AA-12118-00	LOCK, VALVE SPRING RETAINER	4	4	4	4	
11	1WG-12118-00	LOCK, VALVE SPRING RETAINER	4	4	4	4	
12	5EB-12153-10	LIFTER, VALVE	2	2	2	2	YELLOW
	5EB-12153-09	LIFTER, VALVE (O/S)	2	2	2	2	GREEN GREEN
13	3FV-12153-10	LIFTER, VALVE	2	2	2	2	YELLOW
	3FV-12153-09	LIFTER, VALVE (O/S)	2	2	2	2	GREEN GREEN
14	3LD-12168-00	PAD, ADJUSTING (1.20)	4	4	4	4	UR
	3LD-12168-20	PAD, ADJUSTING (1.25)	4	4	4	4	UR
	3LD-12168-40	PAD, ADJUSTING (1.30)	4	4	4	4	UR
	3LD-12168-60	PAD, ADJUSTING (1.35)	4	4	4	4	UR
	3LD-12168-80	PAD, ADJUSTING (1.40)	4	4	4	4	UR
	3LD-12168-A0	PAD, ADJUSTING (1.45)	4	4	4	4	UR
	3LD-12168-F0	PAD, ADJUSTING (1.50)	4	4	4	4	UR
	3LD-12168-H1	PAD, ADJUSTING (1.55)	4	4	4	4	UR
	3LD-12168-K1	PAD, ADJUSTING (1.60)	4	4	4	4	UR
	3LD-12168-M1	PAD, ADJUSTING (1.65)	4	4	4	4	UR
	3LD-12168-R1	PAD, ADJUSTING (1.70)	4	4	4	4	UR
	3LD-12168-U1	PAD, ADJUSTING (1.75)	4	4	4	4	UR

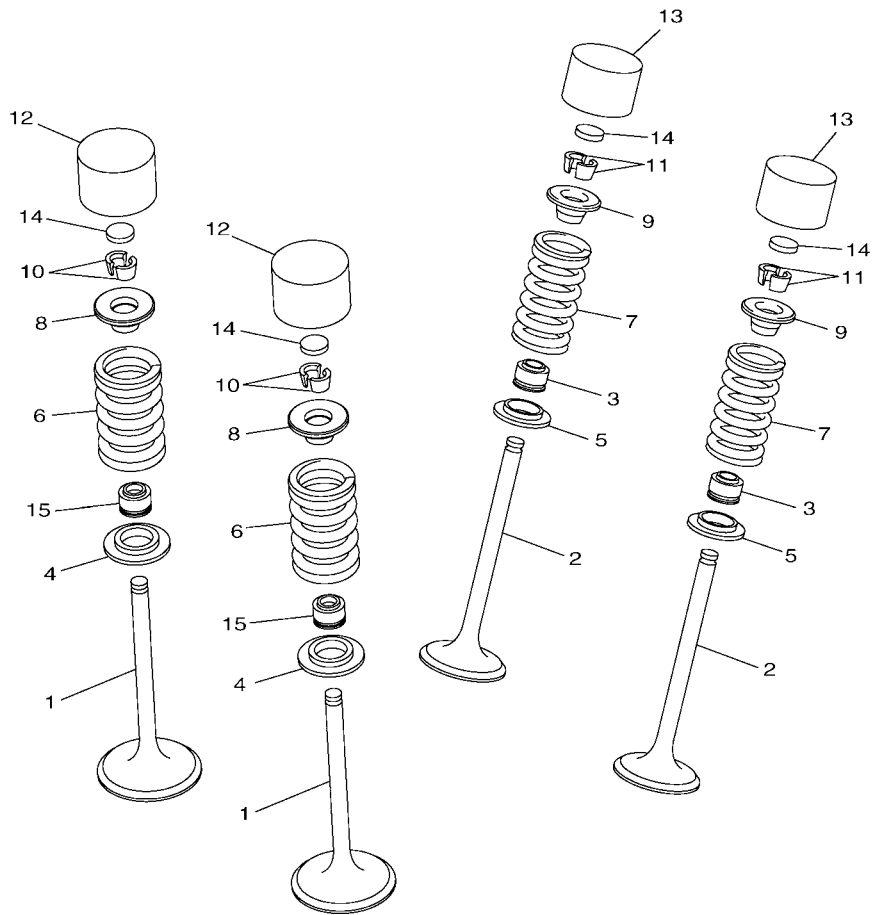

1SM1110-N030

FIG. 3 VALVE

REF. NO.	PART NO.	DESCRIPTION	1SM1	1SM2	1SM3	1SM4	REMARKS
14	3LD-12168-W1	PAD, ADJUSTING (1.80)	4	4	4	4	UR
	3LD-12168-Y1	PAD, ADJUSTING (1.85)	4	4	4	4	UR
	3LD-12169-11	PAD, ADJUSTING (1.90)	4	4	4	4	UR
	3LD-12169-31	PAD, ADJUSTING (1.95)	4	4	4	4	UR
	3LD-12169-50	PAD, ADJUSTING (2.00)	4	4	4	4	UR
	3LD-12169-70	PAD, ADJUSTING (2.05)	4	4	4	4	UR
	3LD-12169-90	PAD, ADJUSTING (2.10)	4	4	4	4	UR
	3LD-12169-E0	PAD, ADJUSTING (2.15)	4	4	4	4	UR
	3LD-12169-G0	PAD, ADJUSTING (2.20)	4	4	4	4	UR
	3LD-12169-J0	PAD, ADJUSTING (2.25)	4	4	4	4	UR
	3LD-12169-L0	PAD, ADJUSTING (2.30)	4	4	4	4	UR
	3LD-12169-N0	PAD, ADJUSTING (2.35)	4	4	4	4	UR
	3LD-12169-T0	PAD, ADJUSTING (2.40)	4	4	4	4	UR
15	33M-12119-00	SEAL, VALVE STEM	2	2	2	2	

FIG. 5 WATER PUMP

REF. NO.	PART NO.	DESCRIPTION	ISM1	ISM2	ISM3	ISM4	REMARKS
1	1SM-12450-00	IMPELLER SHAFT ASSY	1	1	1	1	
2	93102-08004	OIL SEAL	1	1	1	1	
3	93102-08307	OIL SEAL	1	1	1	1	
4	93300-60801	BEARING	1	1	1	1	KOYO
5	1SM-12453-00	GEAR	1	1	1	1	
6	93603-12007	PIN, DOWEL	1	1	1	1	
7	90387-08032	COLLAR	1	1	1	1	
8	90201-08512	WASHER, PLATE	2	2	2	2	
9	93440-07182	CIRCLIP	1	1	1	1	
10	33D-12422-00	COVER, HOUSING	1	1	1	1	
11	33D-12427-00	GASKET, HOUSING COVER 1	1	1	1	1	
12	93604-10011	PIN, DOWEL	2	2	2	2	
13	95022-06025	BOLT, FLANGE	4	4	4	4	
14	95022-06010	BOLT, FLANGE	1	1	1	1	
15	90430-06014	GASKET	1	1	1	1	
16	5NL-12564-00	PIPE, WATER	1	1	1	1	
17	93210-16716	O-RING	1	1	1	1	

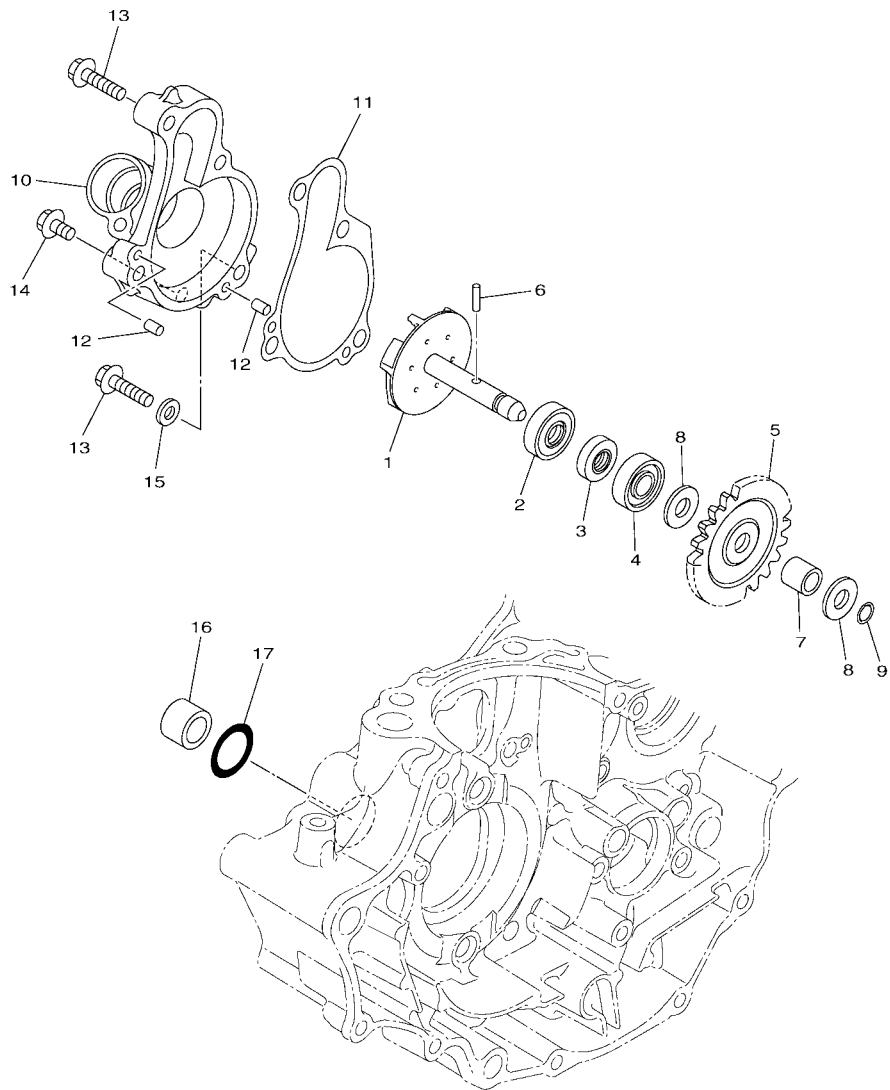

1SM1110-N050

FIG. 6 RADIATOR & HOSE

REF. NO.	PART NO.	DESCRIPTION	1SM1	1SM2	1SM3	1SM4	REMARKS
1	1SL-12482-00	PIPE 2	1	1	1	1	
2	95022-06012	BOLT, FLANGE	1	1	1	1	
3	93210-16500	O-RING	1	1	1	1	
4	1SM-12446-00	JOINT	1	1	1	1	
5	93210-16275	O-RING	1	1	1	1	
6	95022-06020	BOLT, FLANGE	1	1	1	1	
7	1SL-1240A-00	RADIATOR ASSY	1	1	1	1	
8	1SL-12461-00	RADIATOR COMP	1	1	1	1	
9	5SL-12462-00	CAP, RADIATOR	1	1	1	1	
10	33D-12465-00	DAMPER, RADIATOR	2	2	2	2	
11	5YT-24665-00	DAMPER	1	1	1	1	
12	91A20-05065	TUBE, FLEXIBLE VINYL	1	1	1	1	
13	90467-090A2	CLIP	1	1	1	1	
14	1SM-12576-00	HOSE 1	1	1	1	1	
15	1SL-12577-00	HOSE 2	1	1	1	1	
16	1SM-12578-00	HOSE 3	1	1	1	1	
17	1SM-12579-00	HOSE 4	1	1	1	1	
18	90450-28001	HOSE CLAMP ASSY	3	3	3	3	
19	90450-25001	HOSE CLAMP ASSY	3	3	3	3	
20	90450-22001	HOSE CLAMP ASSY	2	2	2	2	
21	90480-15012	GROMMET	4	4	4	4	
22	90387-06065	COLLAR	4	4	4	4	
23	90119-06262	BOLT, WITH WASHER	4	4	4	4	

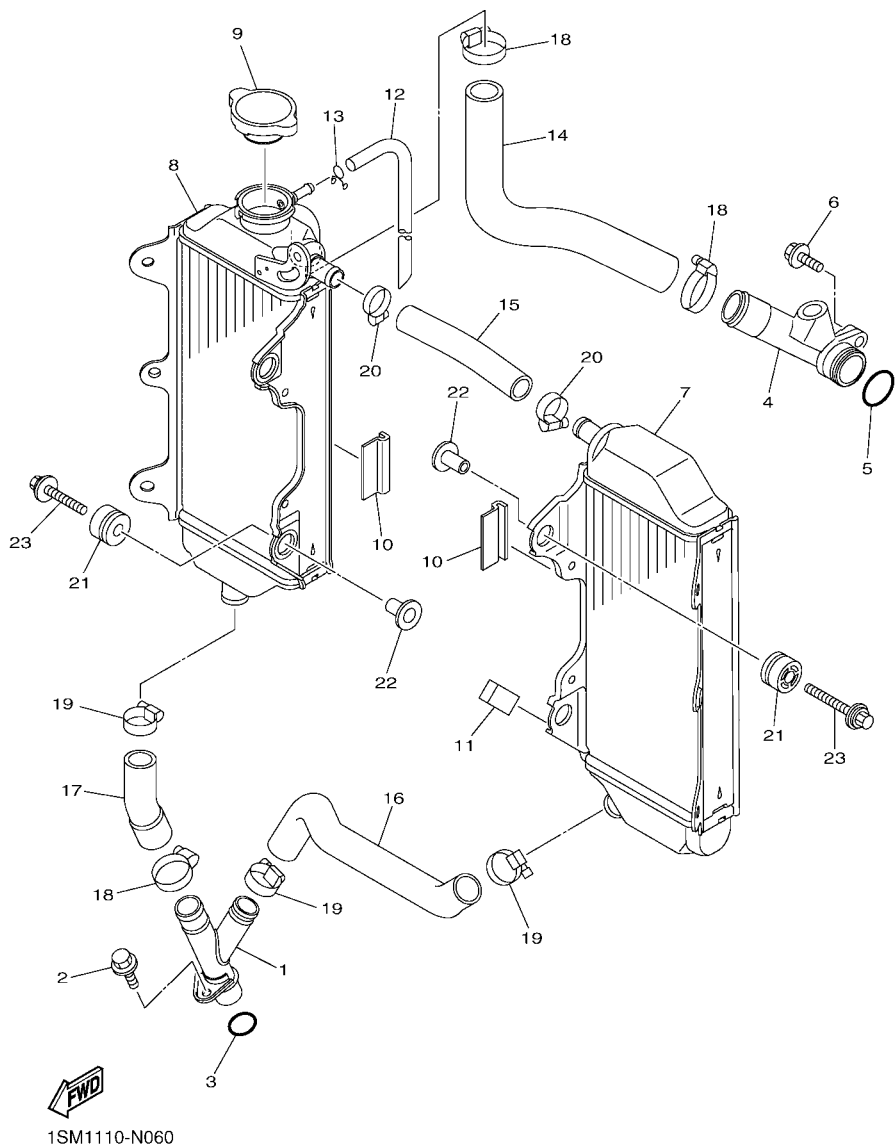
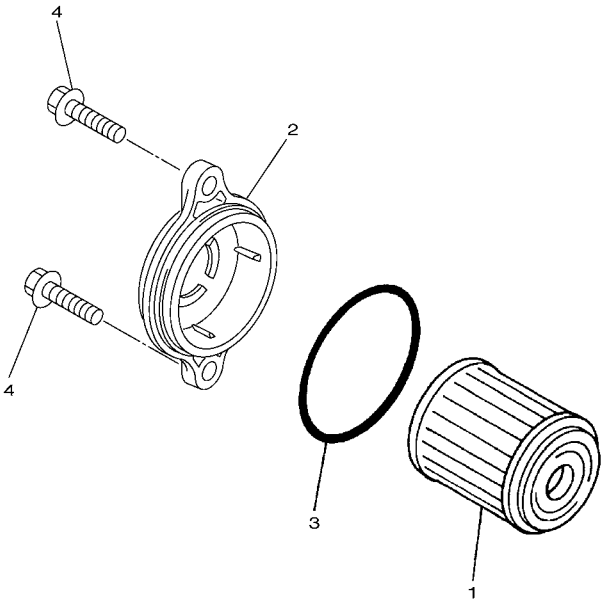

FIG. 8 OIL CLEANER



REF. NO.	PART NO.	DESCRIPTION	1SM1	1SM2	1SM3	1SM4	REMARKS
1	5D3-13440-01	ELEMENT ASSY, OIL CLEANER	1	1	1	1	
2	1SL-13447-00	COVER, OIL ELEMENT	1	1	1	1	
3	93210-45708	O-RING	1	1	1	1	
4	95022-06016	BOLT, FLANGE	2	2	2	2	



1SL1110-N080

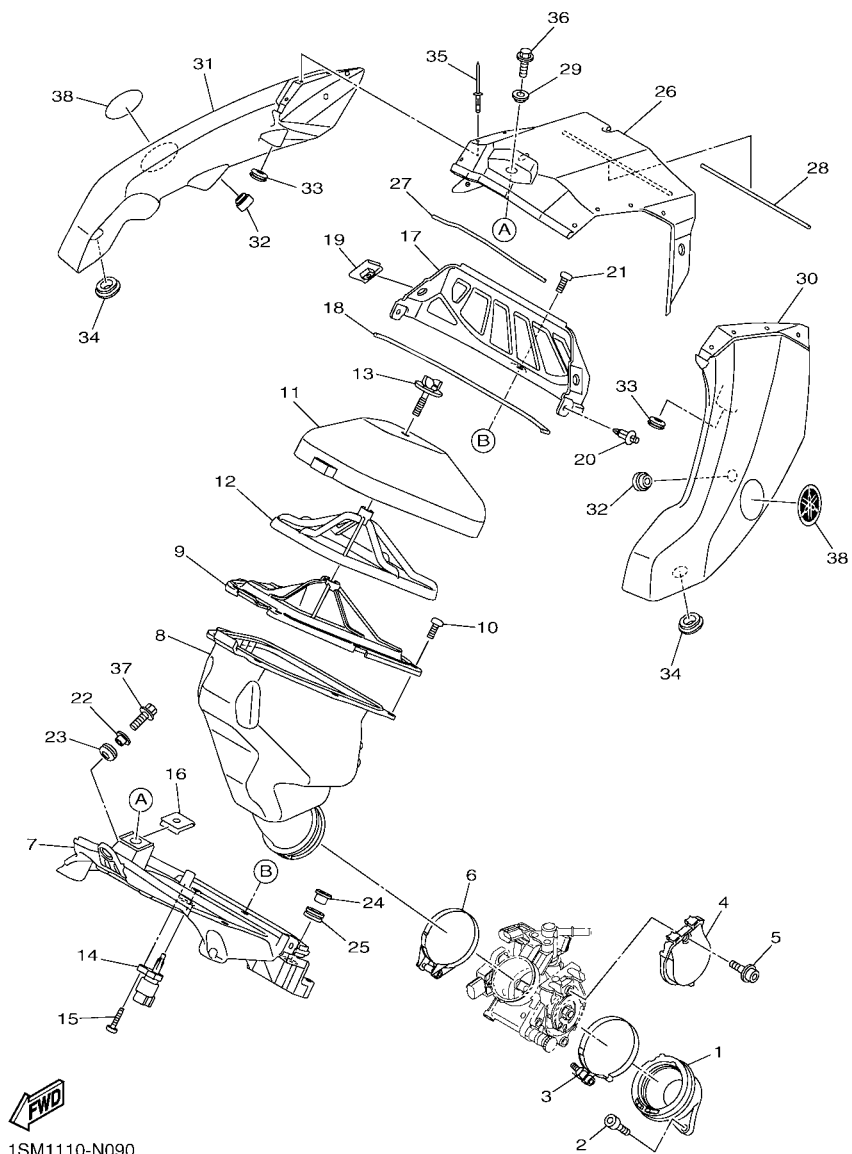

1SM1110-N090

FIG. 9 INTAKE

REF. NO.	PART NO.	DESCRIPTION	1SM1	1SM2	1SM3	1SM4	REMARKS
1	1SM-13597-00	JOINT, CARBURETOR 3	1	1	1	1	
2	91312-06020	BOLT	2	2	2	2	
3	90450-60004	HOSE CLAMP ASSY	1	1	1	1	
4	1SL-14293-00	COVER 1	1	1	1	1	
5	90110-05066	BOLT, HEXAGON SOCKET HEAD	1	1	1	1	
6	90450-58007	HOSE CLAMP ASSY	1	1	1	1	
7	1SL-14411-00	CASE, AIR CLEANER 1	1	1	1	1	
8	1SM-14453-00	JOINT, AIR CLEANER 1	1	1	1	1	
9	1SL-14459-00	HOLDER, GUIDE	1	1	1	1	
10	98502-05014	SCREW, PAN HEAD	8	8	8	8	
11	1SL-14451-00	ELEMENT, AIR CLEANER	1	1	1	1	
12	1SL-14458-00	GUIDE	1	1	1	1	
13	1SL-14428-00	BOLT	1	1	1	1	
14	8FP-85886-00	SENSOR, AIR TEMPERATURE	1	1	1	1	
15	97702-50520	SCREW, TAPPING	1	1	1	1	
16	90183-061A0	NUT, SPRING	1	1	1	1	
17	1SL-14422-00	CAP, CLEANER CASE 2	1	1	1	1	
18	1SL-14462-00	SEAL	1	1	1	1	
19	90183-061A0	NUT, SPRING	2	2	2	2	
20	90269-06008	RIVET	2	2	2	2	
21	98502-05014	SCREW, PAN HEAD	1	1	1	1	
22	90387-087L0	COLLAR	1	1	1	1	
23	90480-12237	GROMMET	1	1	1	1	
24	1SL-14442-00	SPACER	2	2	2	2	
25	90480-01027	GROMMET	2	2	2	2	
26	1SL-14412-00	CAP, CLEANER CASE 1	1	1	1	1	UR FOR DPBSE
	1SL-14412-10	CAP, CLEANER CASE 1	1	1		1	UR FOR PWS1

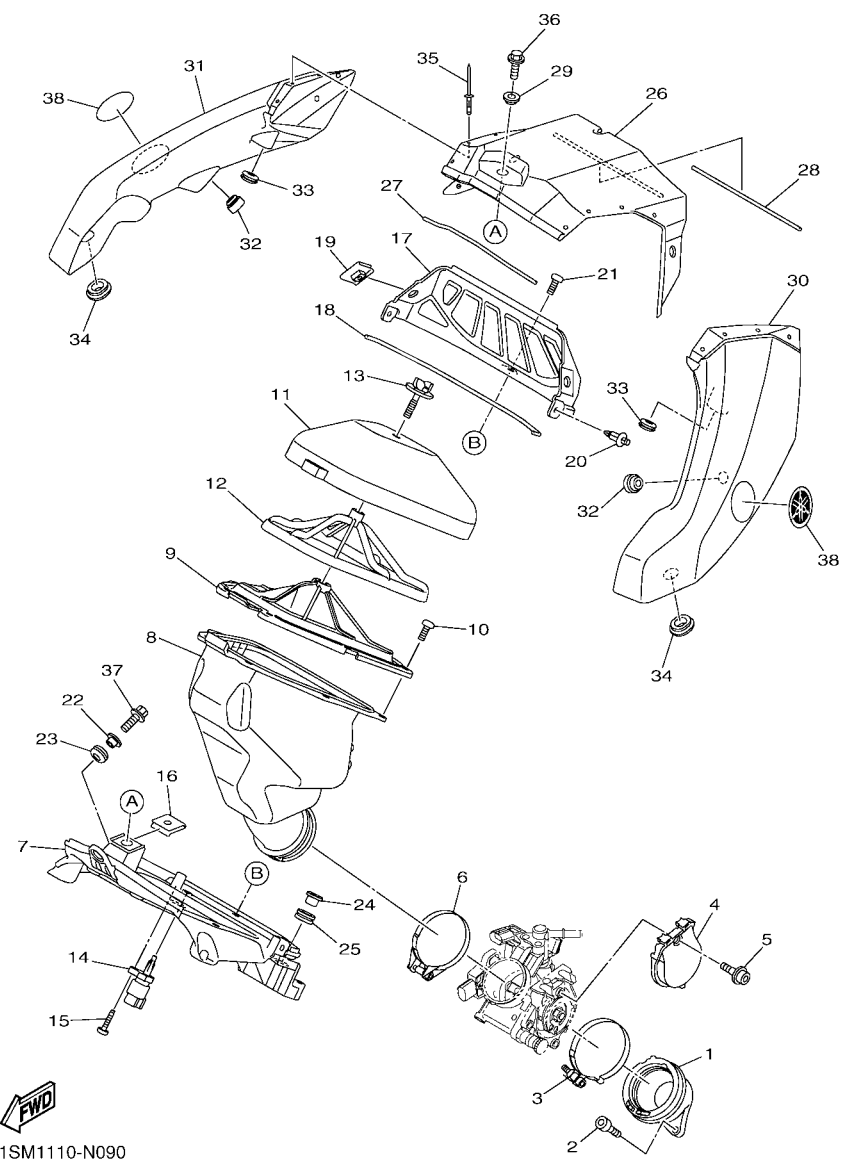

1SM1110-N090

FIG. 9 INTAKE

REF. NO.	PART NO.	DESCRIPTION	1SM1	1SM2	1SM3	1SM4	REMARKS
27	1SL-14452-00	SEAL	1	1	1	1	
28	1SL-14457-00	SEAL	1	1	1	1	
29	90387-07045	COLLAR	3	3	3	3	
30	1SL-14437-00	DUCT	1	1	1	1	
31	1SL-1443A-00	DUCT	1	1	1	1	
32	90480-11298	GROMMET	2	2	2	2	
33	90480-12237	GROMMET	2	2	2	2	
34	90480-01558	GROMMET	2	2	2	2	
35	90267-41004	RIVET, BLIND	12	12	12	12	UR FOR DPBSE
	90267-40014	RIVET, BLIND	12	12		12	UR FOR PWS1
36	90105-06170	BOLT, FLANGE	3	3	3	3	
37	90105-06203	BOLT, FLANGE	3	3	3	3	
38	1SL-2175C-00	TUNING FORK MARK	2	2	2	2	

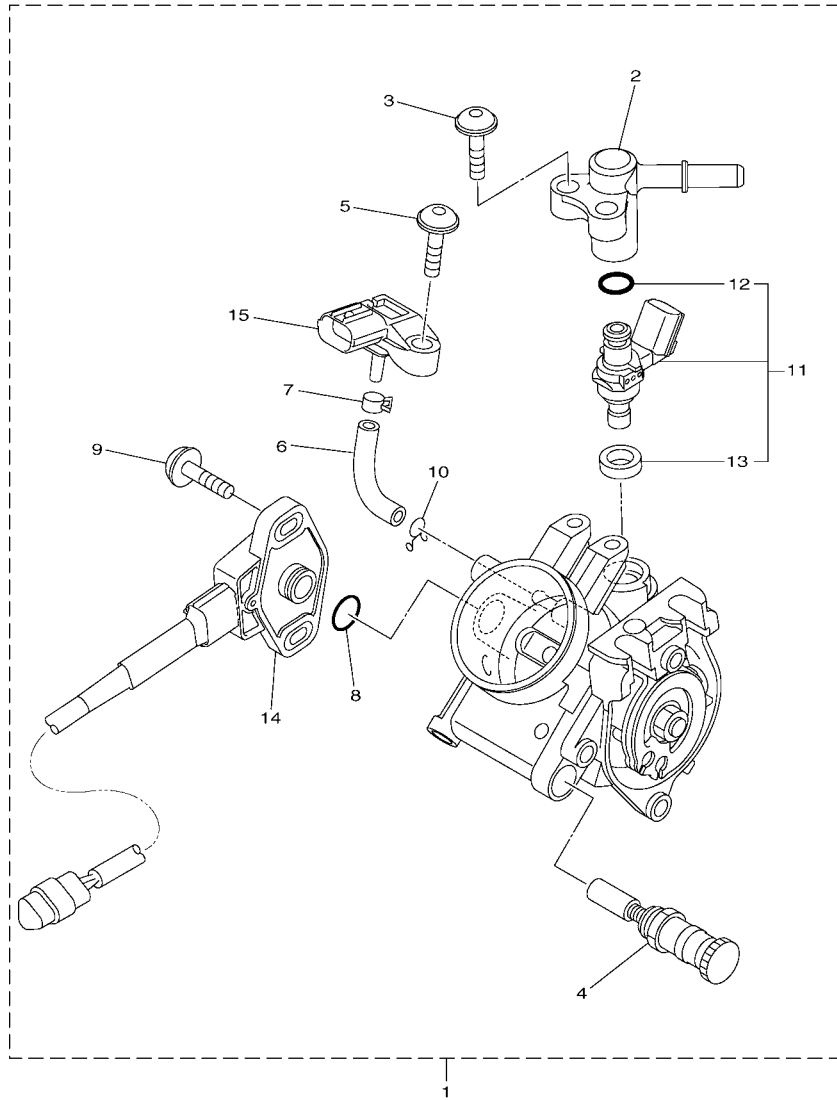

1SM1110-N100

FIG. 10 INTAKE 2

REF. NO.	PART NO.	DESCRIPTION	1SM1	1SM2	1SM3	1SM4	REMARKS
1	1SM-13750-00	THROTTLE BODY ASSY	1	1	1	1	
2	1SM-13938-00	.PIPE	1	1	1	1	
3	33D-14486-00	.SCREW, ROD	2	2	2	2	
4	1SL-14171-00	.PLUNGER, STARTER	1	1	1	1	
5	33D-14325-00	.SCREW, PAN HEAD	1	1	1	1	
6	33D-14348-00	.PIPE 1	1	1	1	1	
7	33D-13577-00	.CLIP	1	1	1	1	
8	1DX-14562-00	.O-RING	1	1	1	1	
9	1DX-14216-00	.SCREW	1	1	1	1	
10	3TJ-14137-40	.CLIP	1	1	1	1	
11	1SM-13761-00	.INJECTOR	1	1	1	1	
12	1SM-14147-00	..O-RING	1	1	1	1	
13	1SM-141A1-00	..SEAL RING	1	1	1	1	
14	1SL-85885-00	.THROTTLE SENSOR ASSY	1	1	1	1	
15	2C0-82380-00	.SENSOR, PRESSURE	1	1	1	1	

FIG. 11 EXHAUST

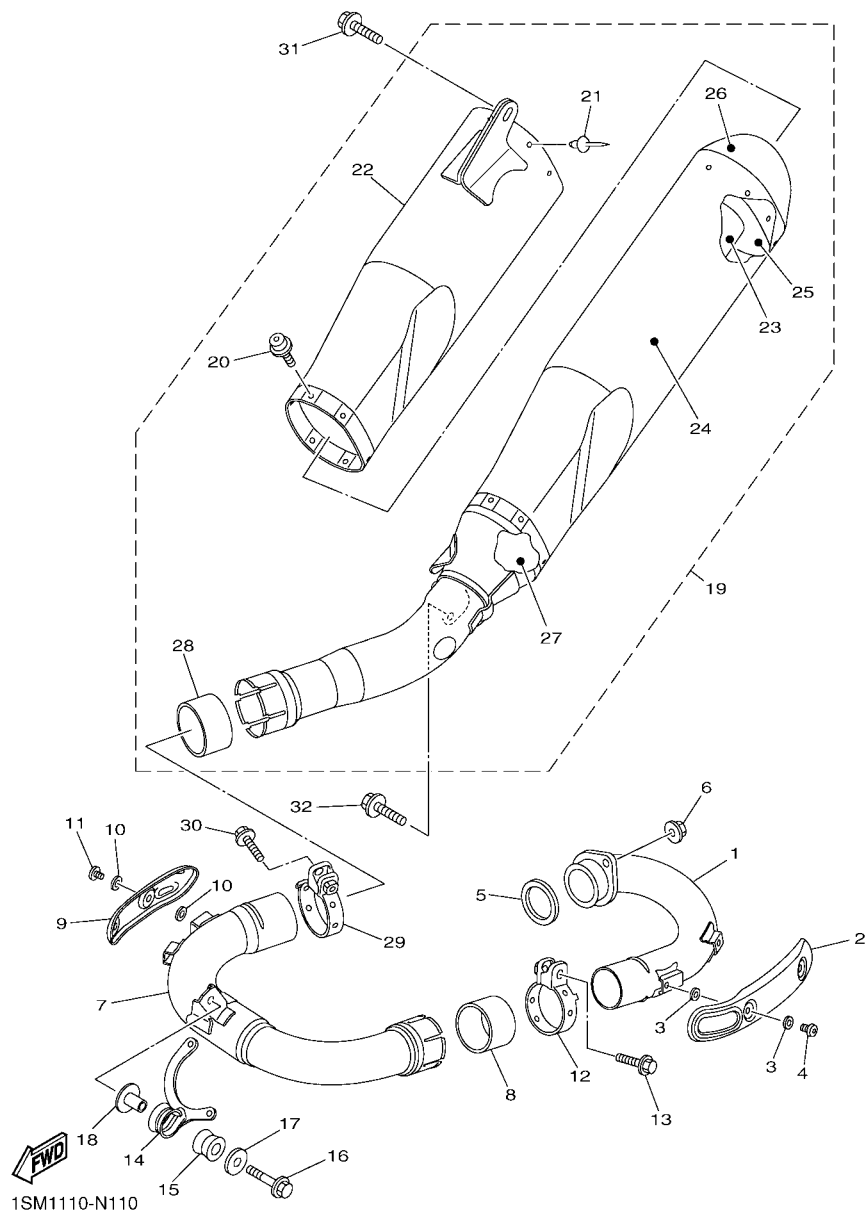

REF. NO.	PART NO.	DESCRIPTION	1SM1	1SM2	1SM3	1SM4	REMARKS
1	1SM-14611-00	PIPE, EXHAUST 1	1	1	1	1	
2	1SL-14628-00	PROTECTOR, EXHAUST PIPE	1	1	1	1	
3	90201-05017	WASHER, PLATE	4	4	4	4	
4	98980-06008	SCREW, BIND	2	2	2	2	
5	5NL-14613-00	GASKET, EXHAUST PIPE	1	1	1	1	
6	95702-08500	NUT, FLANGE	2	2	2	2	
7	1SM-14621-00	PIPE, EXHAUST 2	1	1	1	1	
8	5PX-14755-00	GASKET, SILENCER	1	1	1	1	
9	1SL-1463B-00	PROTECTOR, EXT. PIPE 2	1	1	1	1	
10	90201-05017	WASHER, PLATE	4	4	4	4	
11	98980-06008	SCREW, BIND	2	2	2	2	
12	1SM-14788-00	BAND, SILENCER	1	1	1	1	
13	95024-08040	BOLT, FLG.(SMALL HEAD)	1	1	1	1	
14	1SM-14639-00	STAY, EXHAUST PIPE 1	1	1	1	1	
15	5VY-14747-00	DAMPER, MUFFLER	1	1	1	1	
16	90105-08137	BOLT, FLANGE	1	1	1	1	
17	90201-08061	WASHER, PLATE	1	1	1	1	
18	90387-08081	COLLAR	1	1	1	1	
19	1SM-14750-00	SILENCER ASSY	1				
	1SM-14750-10	SILENCER ASSY		1	1	1	
20	90110-05064	.BOLT, HEXAGON SOCKET HEAD	6	6	6	6	
21	90267-48121	.RIVET, BLIND	8	8	8	8	
22	1SM-1466G-00	.BODY, SILENCER	1	1	1	1	
23	1SM-1469A-00	.FIBER	1				
	1SM-1469A-10	.FIBER		1	1	1	
24	1SM-1477E-00	.FIBER 2	1				
	1SM-1477E-10	.FIBER 2		1	1	1	

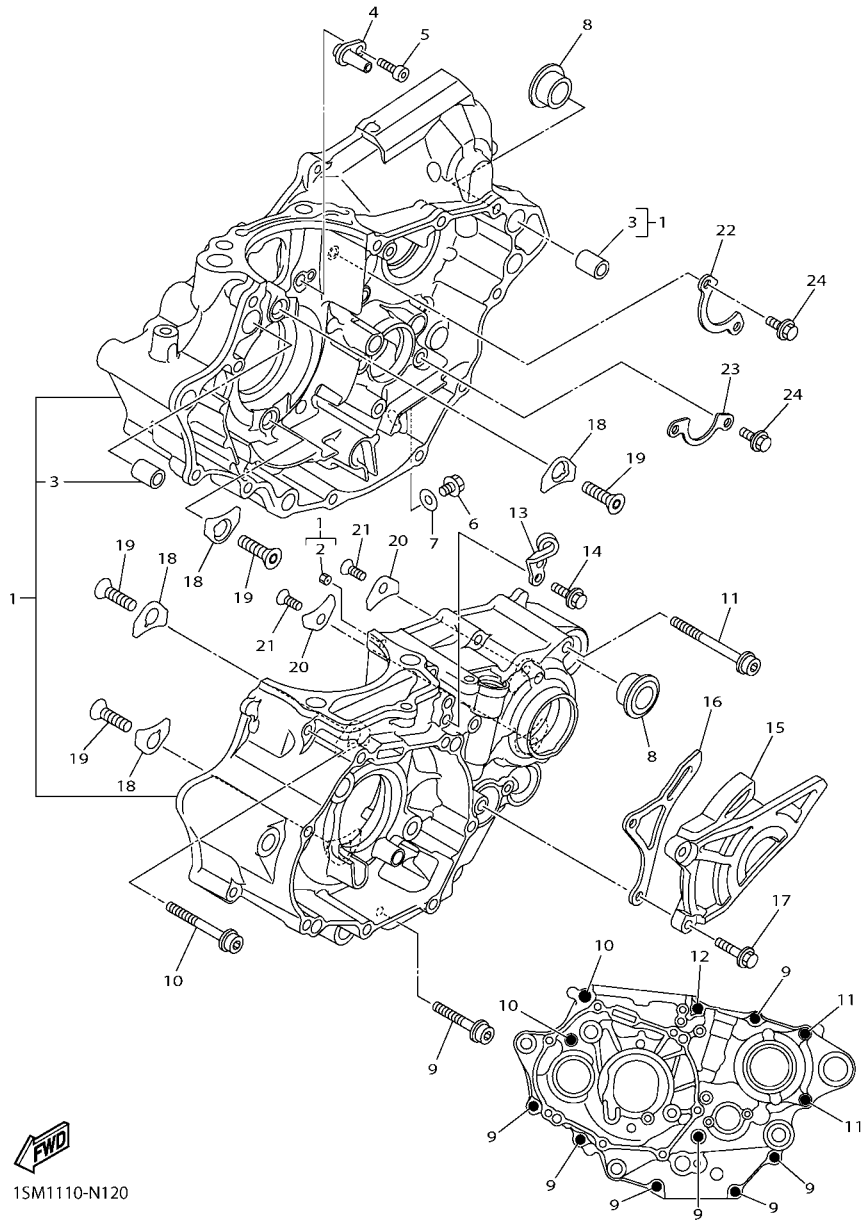

1SM1110-N120

FIG. 12 CRANKCASE

REF. NO.	PART NO.	DESCRIPTION	1SM1	1SM2	1SM3	1SM4	REMARKS
1	1SM-15100-09	CRANKCASE ASSY	1	1	1	1	
2	1SM-15138-00	.NOZZLE 1	1	1	1	1	
3	99530-14016	.PIN, DOWEL	2	2	2	2	
4	1SM-15155-00	NOZZLE 3	1	1	1	1	
5	90110-05032	BOLT, HEXAGON SOCKET HEAD	1	1	1	1	
6	95022-10016	BOLT, FLANGE	1	1	1	1	
7	90430-10188	GASKET	1	1	1	1	
8	90387-17015	COLLAR	2	2	2	2	
9	90110-06391	BOLT, HEXAGON SOCKET HEAD	7	7	7	7	
10	91312-06060	BOLT	2	2	2	2	
11	90110-06392	BOLT, HEXAGON SOCKET HEAD	2	2	2	2	
12	91317-06075	BOLT	1	1	1	1	
13	1SL-15441-00	HOLDER, CLUTCH CABLE	1	1	1	1	
14	90105-06099	BOLT, FLANGE	2	2	2	2	
15	1SL-15421-00	COVER, CRANKCASE 2	1	1	1	1	
16	1SL-17466-00	GUIDE, CHAIN	1	1	1	1	
17	90105-06189	BOLT, FLANGE	2	2	2	2	
18	18P-15383-00	PLATE, BEARING COVER	4	4	4	4	
19	90151-08007	SCREW, COUNTERSUNK	4	4	4	4	
20	4JT-15381-01	PLATE, BEARING COVER	2	2	2	2	
21	90149-06074	SCREW	2	2	2	2	
22	1SM-15388-00	PLATE, BEARING COVER	1	1	1	1	
23	1SL-18562-00	PLATE, STOPPER 2	1	1	1	1	
24	90105-06081	BOLT, FLANGE	4	4	4	4	

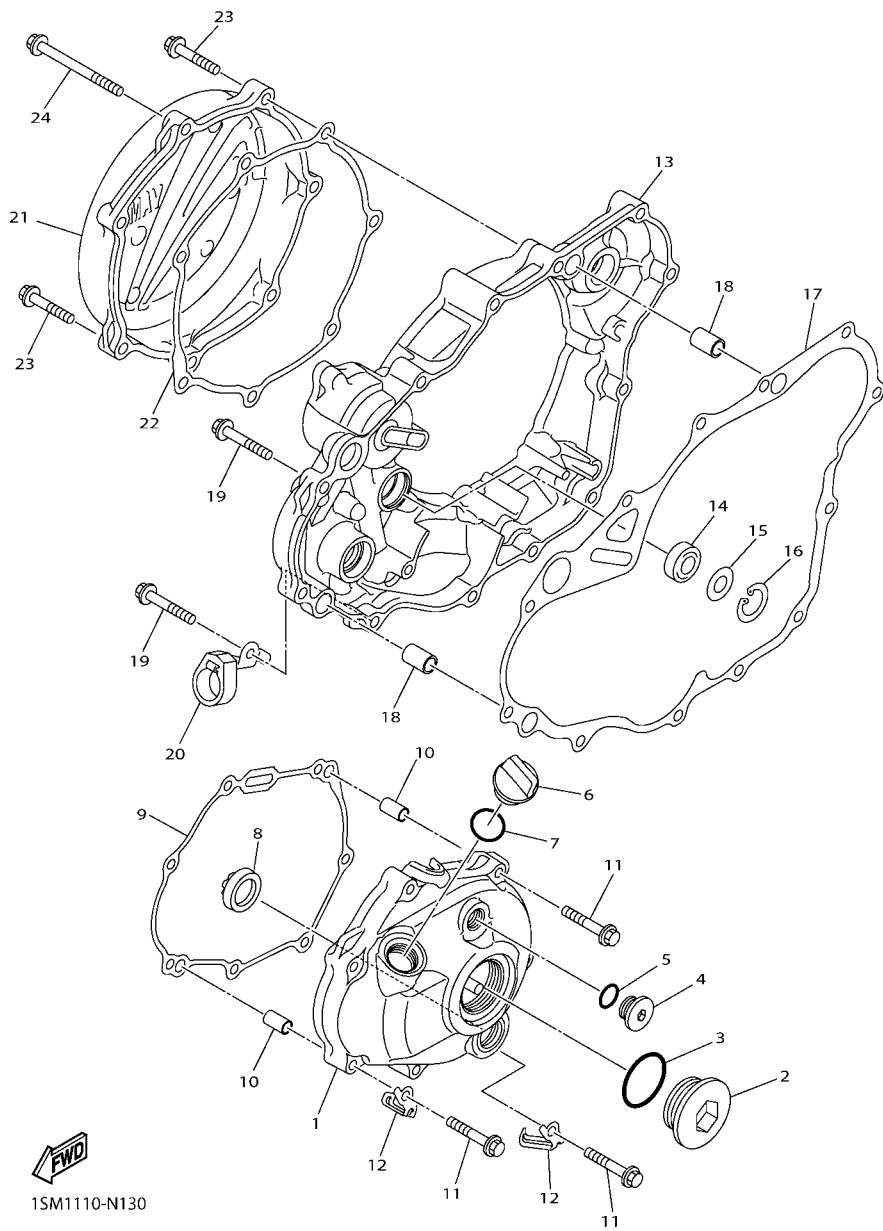

1SM1110-N130

FIG. 13 CRANKCASE COVER 1

REF. NO.	PART NO.	DESCRIPTION	1SM1	1SM2	1SM3	1SM4	REMARKS
1	1SM-15411-00	COVER, CRANKCASE 1	1	1	1	1	
2	90340-36002	PLUG, STRAIGHT SCREW	1	1	1	1	
3	93210-357A3	O-RING	1	1	1	1	
4	90340-14011	PLUG, STRAIGHT SCREW	1	1	1	1	
5	93210-14369	O-RING	1	1	1	1	
6	3Y1-15363-10	PLUG, OIL	1	1	1	1	
7	93210-19123	O-RING	1	1	1	1	
8	3Y1-15361-00	GAUGE, LEVEL	1	1	1	1	
9	1SM-15451-00	GASKET, CRANKCASE COVER 1	1	1	1	1	
10	99530-08016	PIN, DOWEL	2	2	2	2	
11	95022-06030	BOLT, FLANGE	7	7	7	7	
12	90465-08062	CLAMP	2	2	2	2	
13	1SM-15431-00	COVER, CRANKCASE 3	1	1	1	1	
14	93101-14164	OIL SEAL	1	1	1	1	
15	90201-15701	WASHER, PLATE (T=1.0)	1	1	1	1	
16	99009-22500	CIRCLIP	1	1	1	1	
17	1SM-15462-00	GASKET, CRANKCASE COVER 3	1	1	1	1	
18	99530-12016	PIN, DOWEL	2	2	2	2	
19	90105-06102	BOLT, FLANGE	11	11	11	11	
20	17D-15378-00	HOLDER	1	1	1	1	
21	1SM-15415-00	COVER, GENERATOR	1	1	1	1	
22	1SM-15453-00	GASKET	1	1	1	1	
23	95022-06025	BOLT, FLANGE	6	6	6	6	
24	95022-06060	BOLT, FLANGE	1	1	1	1	

FIG. 14 STARTER

REF. NO.	PART NO.	DESCRIPTION	1SM1	1SM2	1SM3	1SM4	REMARKS
1	1SM-15601-00	KICK SHAFT ASSY	1	1	1	1	
2	1SM-15641-00	.GEAR, KICK	1	1	1	1	
3	90201-20685	.WASHER, PLATE (T=0.5)	1	1	1	1	
4	93410-20038	.CIRCLIP	1	1	1	1	
5	2S2-15671-00	.WHEEL, RATCHET	1	1	1	1	
6	90501-160A2	.SPRING, COMPRESSION	1	1	1	1	
7	90201-167P7	.WASHER, PLATE	1	1	1	1	
8	99009-16400	.CIRCLIP	1	1	1	1	
9	5NL-15664-00	.GUIDE, SPRING	1	1	1	1	
10	90508-30743	.SPRING, TORSION	1	1	1	1	
11	214-15674-00	GUIDE, RATCHET WHEEL	1	1	1	1	
12	2NX-15668-00	STOPPER	1	1	1	1	
13	90101-06044	BOLT	2	2	2	2	
14	93102-18278	OIL SEAL	1	1	1	1	
15	1SM-15651-00	GEAR, KICK IDLE	1	1	1	1	
16	90201-177G4	WASHER, PLATE	1	1	1	1	
17	99009-17400	CIRCLIP	1	1	1	1	
18	1SM-15620-00	KICK CRANK ASSY	1	1	1	1	
19	1SM-15621-00	.BOSS, KICK CRANK	1	1	1	1	
20	90501-147A5	.SPRING, COMPRESSION	1	1	1	1	
21	93507-32009	.BALL	1	1	1	1	
22	90151-06045	.SCREW, COUNTERSUNK	1	1	1	1	
23	93210-17570	.O-RING	1	1	1	1	
24	90110-08051	BOLT, HEXAGON SOCKET HEAD	1	1	1	1	
25	90201-08048	WASHER, PLATE	1	1	1	1	

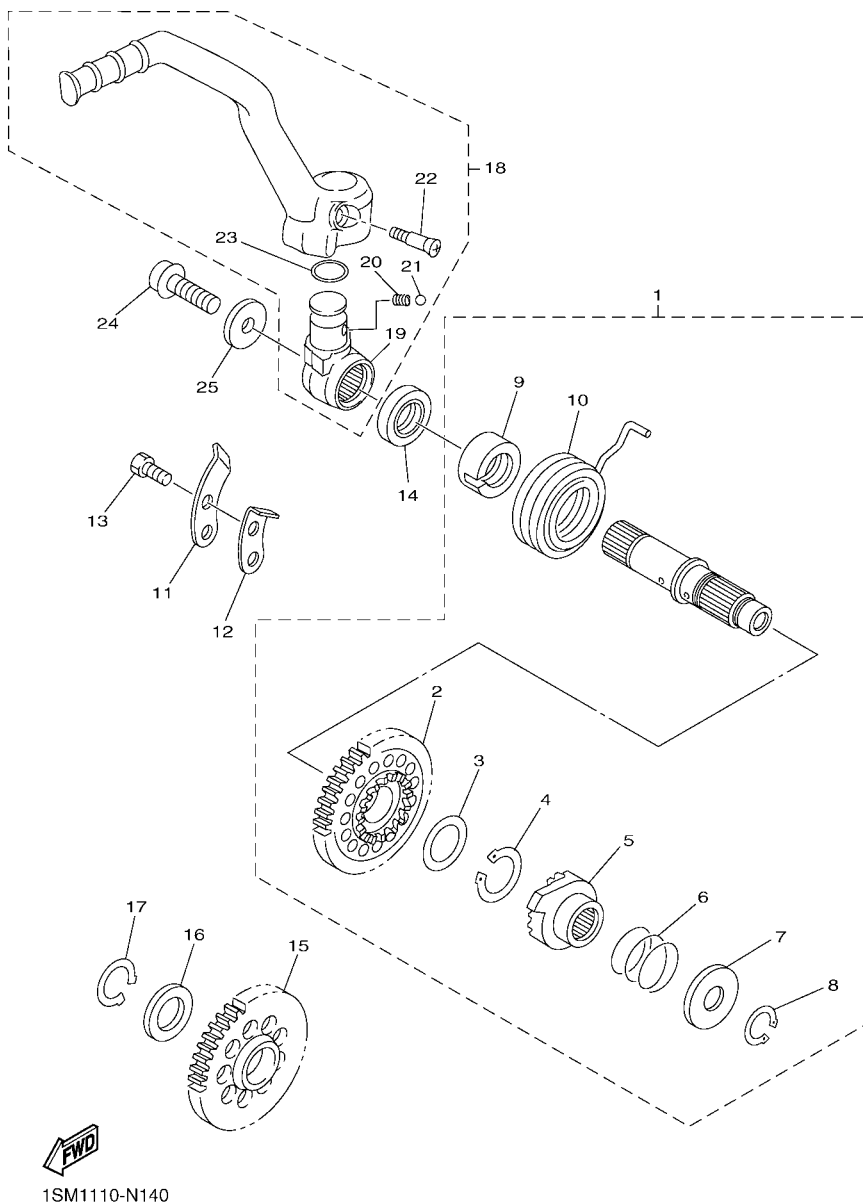

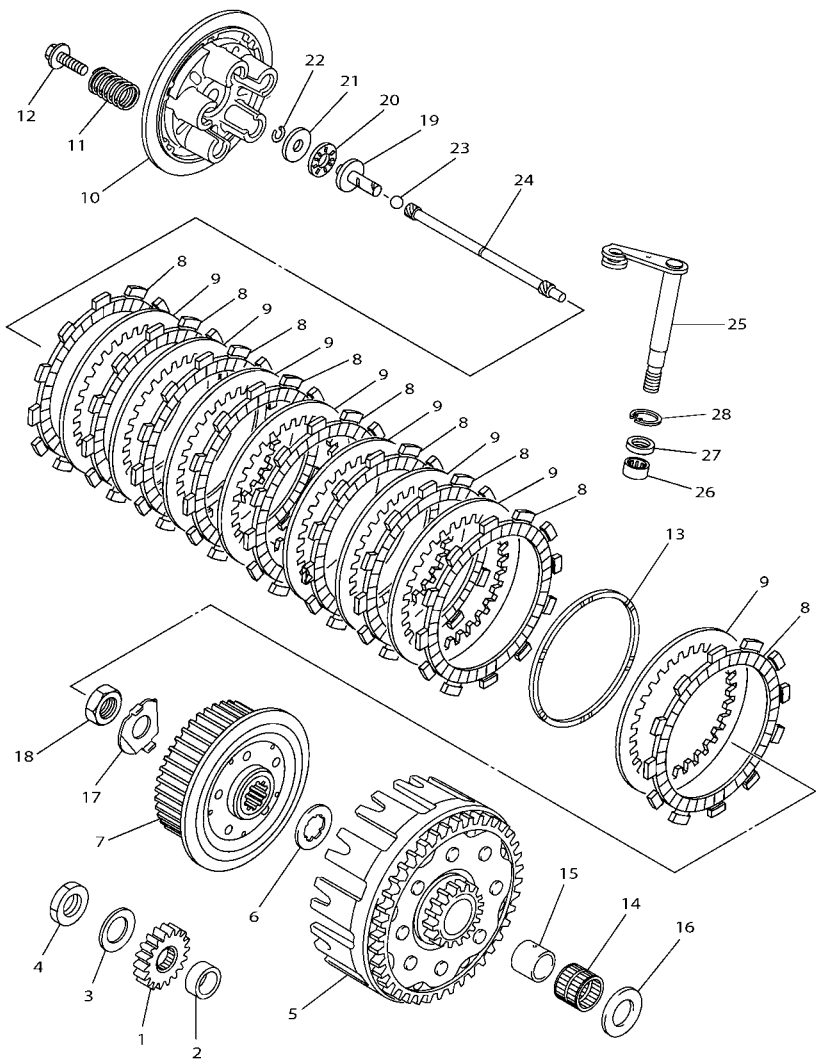

1SM1110-N150

FIG. 15 CLUTCH

REF. NO.	PART NO.	DESCRIPTION	1SM1	1SM2	1SM3	1SM4	REMARKS
1	1SM-16111-00	GEAR, PRIMARY DRIVE	1	1	1	1	
2	90387-19008	COLLAR	1	1	1	1	
3	90208-16019	WASHER, CONICAL SPRING	1	1	1	1	
4	90170-16003	NUT	1	1	1	1	
5	1SM-16150-00	PRIMARY DRIVEN GEAR COMP.	1	1	1	1	
6	1SM-16154-00	PLATE, THRUST 1	1	1	1	1	
7	5NL-16371-40	BOSS, CLUTCH	1	1	1	1	
8	5XC-16321-00	PLATE, FRICTION	9	9	9	9	
9	5NL-16325-00	PLATE, CLUTCH 2	8	8	8	8	
10	1SM-16351-00	PLATE, PRESSURE 1	1	1	1	1	
11	90501-230A6	SPRING, COMPRESSION	5	5	5	5	
12	90159-06029	SCREW, WITH WASHER	5	5	5	5	
13	1SM-16383-00	SPRING., CUSHION	1	1	1	1	
14	93310-225N0	BEARING	1	1	1	1	
15	1SM-16181-00	SPACER 1	1	1	1	1	
16	90201-20611	WASHER, PLATE	1	1	1	1	
17	90215-16289	WASHER, LOCK	1	1	1	1	
18	90170-16326	NUT	1	1	1	1	
19	1SM-16356-00	ROD, PUSH 1	1	1	1	1	
20	93340-21008	BEARING	1	1	1	1	
21	90201-080H1	WASHER, PLATE	1	1	1	1	
22	93440-07182	CIRCLIP	1	1	1	1	
23	93511-32027	BALL	1	1	1	1	
24	1SM-16357-00	ROD, PUSH 2	1	1	1	1	
25	1SM-16381-00	PUSH LEVER COMP.	1	1	1	1	
26	93317-11096	BEARING	1	1	1	1	
27	93102-10008	OIL SEAL	1	1	1	1	

FIG. 15 CLUTCH

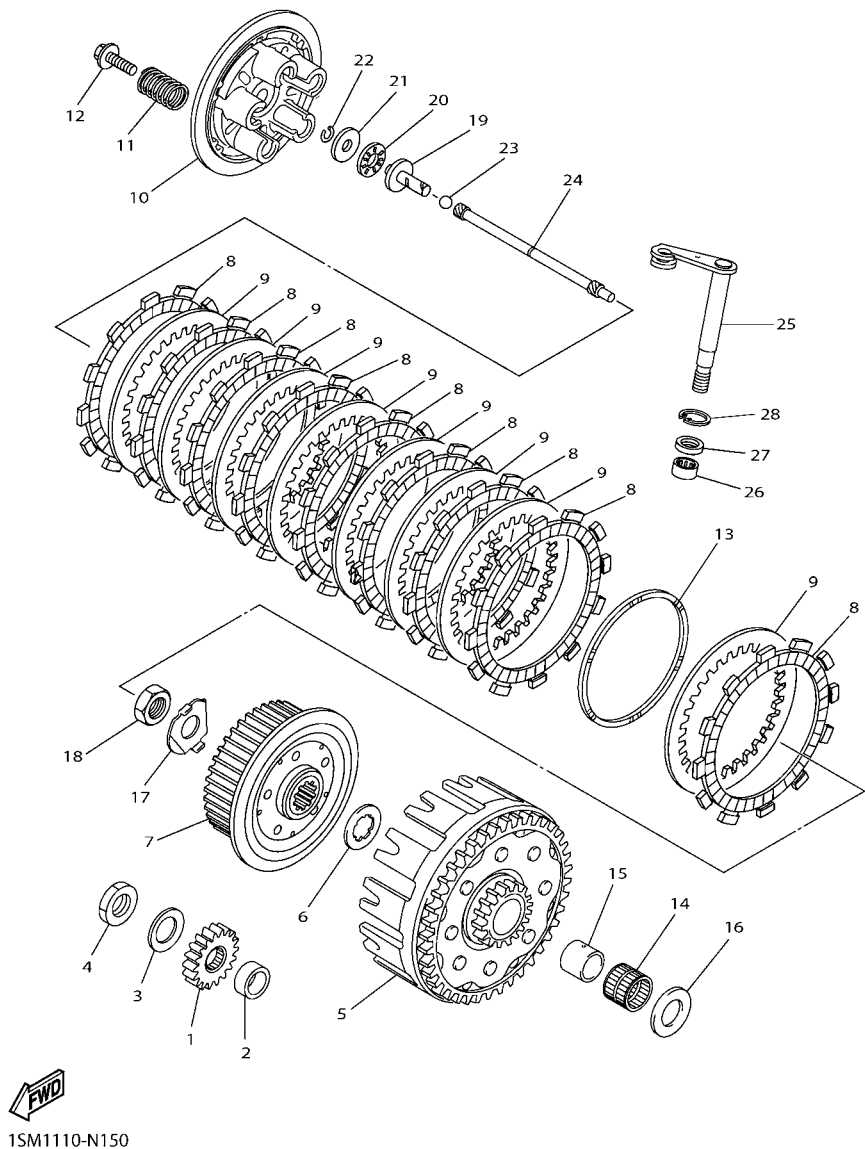

REF. NO.	PART NO.	DESCRIPTION	1SM1	1SM2	1SM3	1SM4	REMARKS
28	99009-18500	CIRCLIP	1	1	1	1	

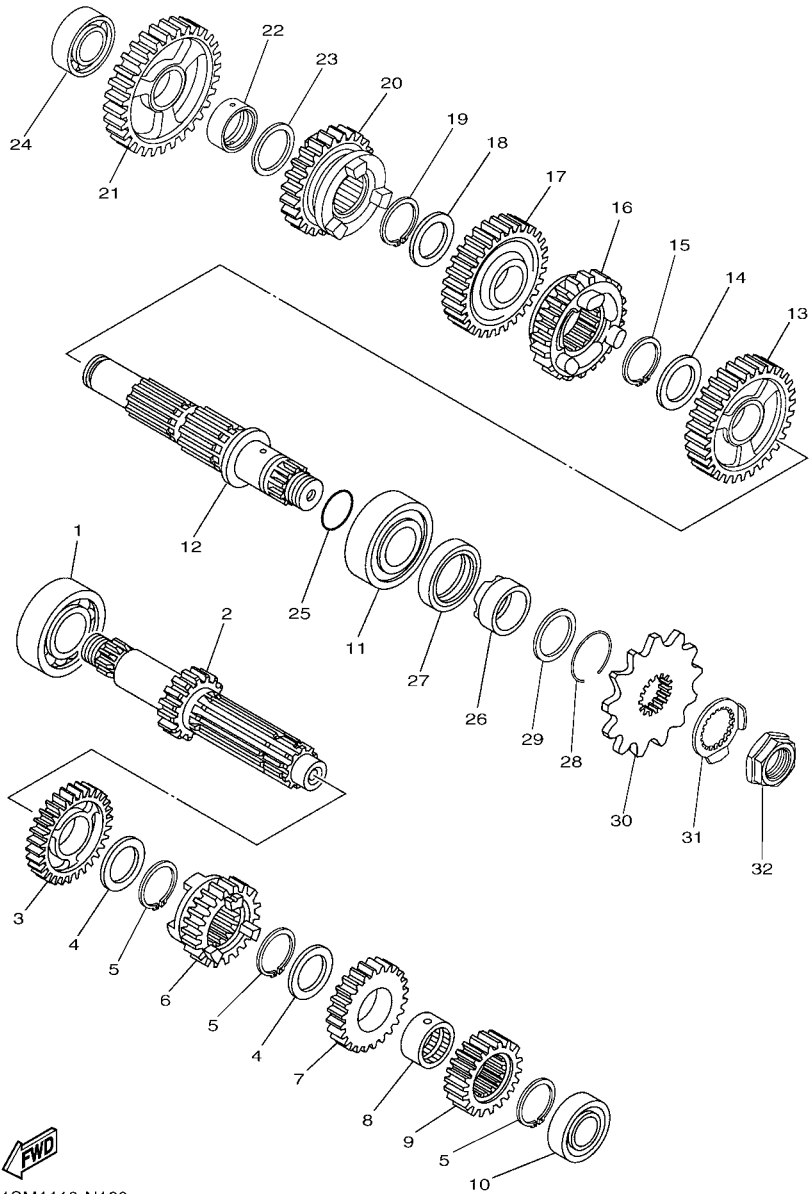

1SM1110-N160

FIG. 16 TRANSMISSION

REF. NO.	PART NO.	DESCRIPTION	1SM1	1SM2	1SM3	1SM4	REMARKS
1	93306-00426	BEARING	1	1	1	1	
2	1SM-17411-00	AXLE,MAIN(14T)	1	1	1	1	
3	1SM-17151-00	GEAR, 5TH PINION (24T)	1	1	1	1	
4	90209-20008	WASHER	2	2	2	2	
5	93410-22039	CIRCLIP	3	3	3	3	
6	1SM-17131-00	GEAR, 3RD PINION (18T)	1	1	1	1	
7	1SM-17141-00	GEAR, 4TH PINION (18T)	1	1	1	1	
8	90387-20006	COLLAR	1	1	1	1	
9	1SM-17121-00	GEAR, 2ND PINION (16T)	1	1	1	1	
10	93306-20336	BEARING	1	1	1	1	
11	93306-27209	BEARING	1	1	1	1	
12	1SM-1742A-00	DRIVE AXLE ASSY.,2	1	1	1	1	
13	1SM-17221-00	GEAR, 2ND WHEEL (28T)	1	1	1	1	
14	90209-23012	WASHER	1	1	1	1	
15	93410-26067	CIRCLIP	1	1	1	1	
16	1SM-17241-00	GEAR, 4TH WHEEL (22T)	1	1	1	1	
17	17D-17231-10	GEAR, 3RD WHEEL (26T)	1	1	1	1	
18	90209-20008	WASHER	1	1	1	1	
19	93410-22039	CIRCLIP	1	1	1	1	
20	1SM-17251-00	GEAR, 5TH WHEEL (25T)	1	1	1	1	
21	1SM-17211-00	GEAR, 1ST WHEEL (30T)	1	1	1	1	
22	90387-17012	COLLAR	1	1	1	1	
23	90201-177G4	WASHER, PLATE	1	1	1	1	
24	93306-20351	BEARING	1	1	1	1	
25	93210-196A4	O-RING	1	1	1	1	
26	90387-22033	COLLAR	1	1	1	1	
27	93102-28012	OIL SEAL	1	1	1	1	

FIG. 17 SHIFT CAM & FORK

REF. NO.	PART NO.	DESCRIPTION	1SM1	1SM2	1SM3	1SM4	REMARKS
1	1SM-18541-00	CAM, SHIFT	1	1	1	1	
2	3D7-18542-00	POINT, NEUTRAL	1	1	1	1	
3	90501-06022	SPRING, COMPRESSION	1	1	1	1	
4	93306-90409	BEARING	1	1	1	1	
5	93306-80502	BEARING	1	1	1	1	
6	1SM-18511-00	FORK, SHIFT 1	1	1	1	1	
7	1SM-18512-00	FORK, SHIFT 2	1	1	1	1	
8	1SM-18513-00	FORK, SHIFT 3	1	1	1	1	
9	1SL-18531-00	BAR, SHIFT FORK GUIDE 1	1	1	1	1	
10	1SL-18535-00	BAR, SHIFT FORK GUIDE 2	1	1	1	1	
11	90501-064L1	SPRING, COMPRESSION	4	4	4	4	
12	1SL-18140-00	STOPPER LEVER ASSY	1	1	1	1	
13	90508-26080	SPRING, TORSION	1	1	1	1	
14	90159-06027	SCREW, WITH WASHER	1	1	1	1	
15	33D-18175-00	SPACER	1	1	1	1	

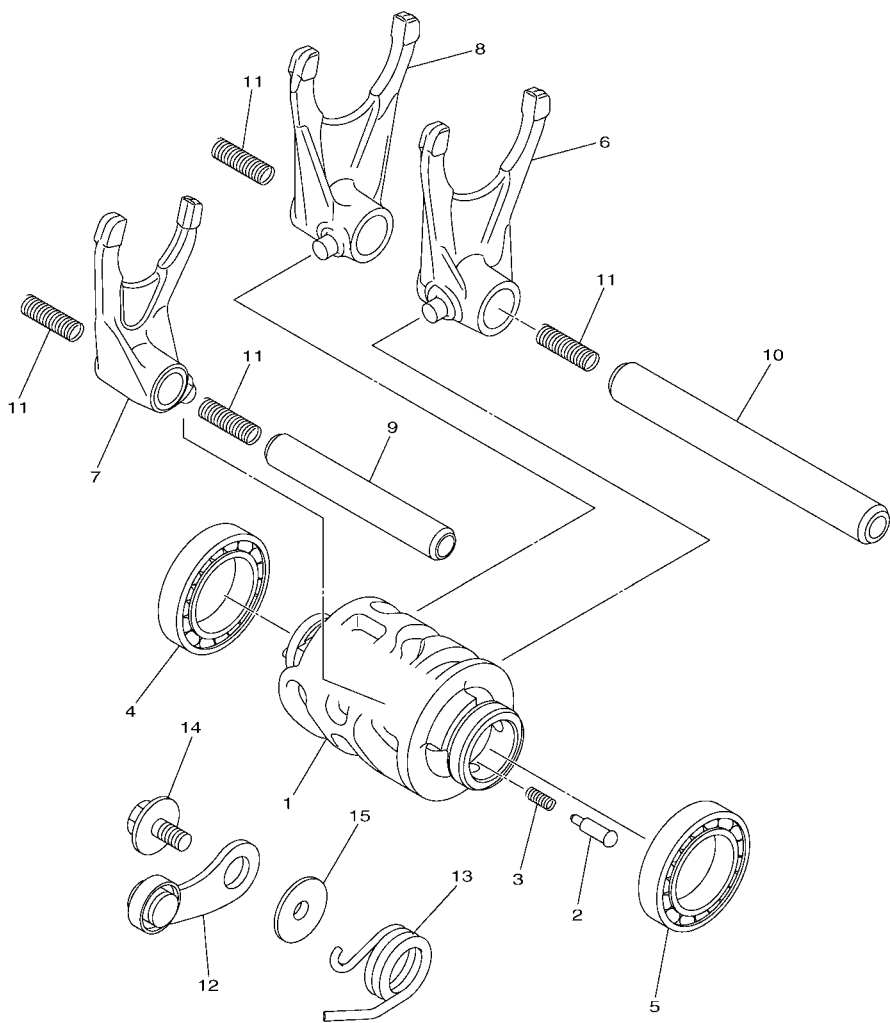

1SM1110-N170

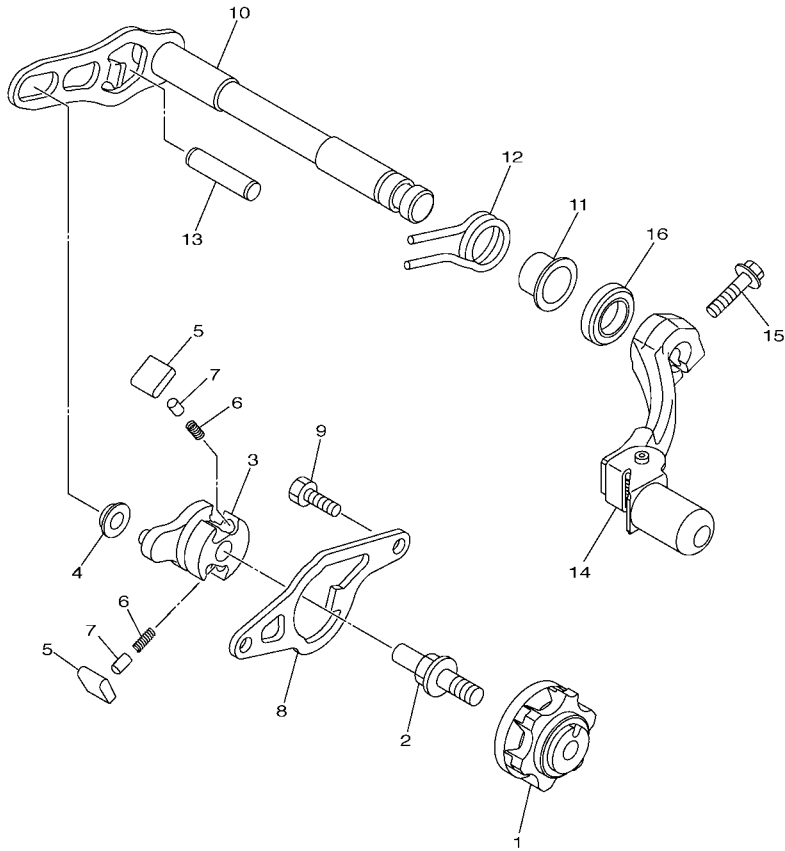

1SL1110-N180

FIG. 18 SHIFT SHAFT

REF. NO.	PART NO.	DESCRIPTION	1SM1	1SM2	1SM3	1SM4	REMARKS
1	1SL-18185-00	SEGMENT	1	1	1	1	
2	3XJ-18173-10	PIN, SHIFT	1	1	1	1	
3	1SL-18122-00	LEVER, SHIFT 2	1	1	1	1	
4	3XJ-18178-00	ROLLER, SHIFT LEVER	1	1	1	1	
5	3XJ-18182-00	PAWL, SHIFTER	2	2	2	2	
6	90501-052G5	SPRING, COMPRESSION	2	2	2	2	
7	3XJ-18184-00	PIN, PAWL	2	2	2	2	
8	1SL-18172-00	GUIDE, SHIFT	1	1	1	1	
9	90101-06041	BOLT	2	2	2	2	
10	1SM-18101-00	SHIFT SHAFT ASSY	1	1	1	1	
11	90387-14020	COLLAR	1	1	1	1	
12	90508-29023	SPRING, TORSION	1	1	1	1	
13	93608-33002	PIN, DOWEL	1	1	1	1	
14	1SL-18110-00	SHIFT PEDAL ASSY	1	1	1	1	
15	90119-06M12	BOLT, WITH WASHER	1	1	1	1	
16	93109-14010	OIL SEAL	1	1	1	1	

FIG. 19 FRAME

REF. NO.	PART NO.	DESCRIPTION	ISM1	ISM2	ISM3	ISM4	REMARKS
1	1SL-21101-00	FRONT FRAME COMP.	1	1	1	1	
2	17D-21447-00	.BRACKET, FOOTREST	1	1	1	1	
3	17D-21448-00	.BRACKET, FOOTREST	1	1	1	1	
4	90149-10031	.SCREW	4	4	4	4	
5	1SL-21190-00	REAR FRAME COMP.	1	1	1	1	
6	33D-23472-00	PROTECTOR	2	2	2	2	
7	90105-08230	BOLT, FLANGE	4	4	4	4	
8	30X-22178-00	TENSIONER	1	1	1	1	
9	4V4-22184-00	BUSH	1	1	1	1	
10	90201-08045	WASHER, PLATE	2	2	2	2	
11	90387-08041	COLLAR	1	1	1	1	
12	95022-08040	BOLT, FLANGE	1	1	1	1	
13	3JD-22178-20	TENSIONER	1	1	1	1	
14	93300-60839	BEARING	1	1	1	1	
15	90387-086N4	COLLAR	1	1	1	1	
16	90105-08232	BOLT, FLANGE	1	1	1	1	
17	90185-08009	NUT, SELF-LOCKING	1	1	1	1	
18	90201-08043	WASHER, PLATE	1	1	1	1	
19	90105-10176	BOLT, FLANGE	1	1	1	1	
20	90179-10658	NUT	1	1	1	1	
21	90201-10045	WASHER, PLATE	1	1	1	1	
22	1SM-21417-00	BRACKET, FRONT LOWER 1	1	1	1	1	
23	1SM-21418-00	BRACKET, FRONT LOWER 2	1	1	1	1	
24	90105-08143	BOLT, FLANGE	4	4	4	4	
25	90105-10443	BOLT, FLANGE	1	1	1	1	
26	90179-10658	NUT	1	1	1	1	
27	90201-10025	WASHER, PLATE	1	1	1	1	

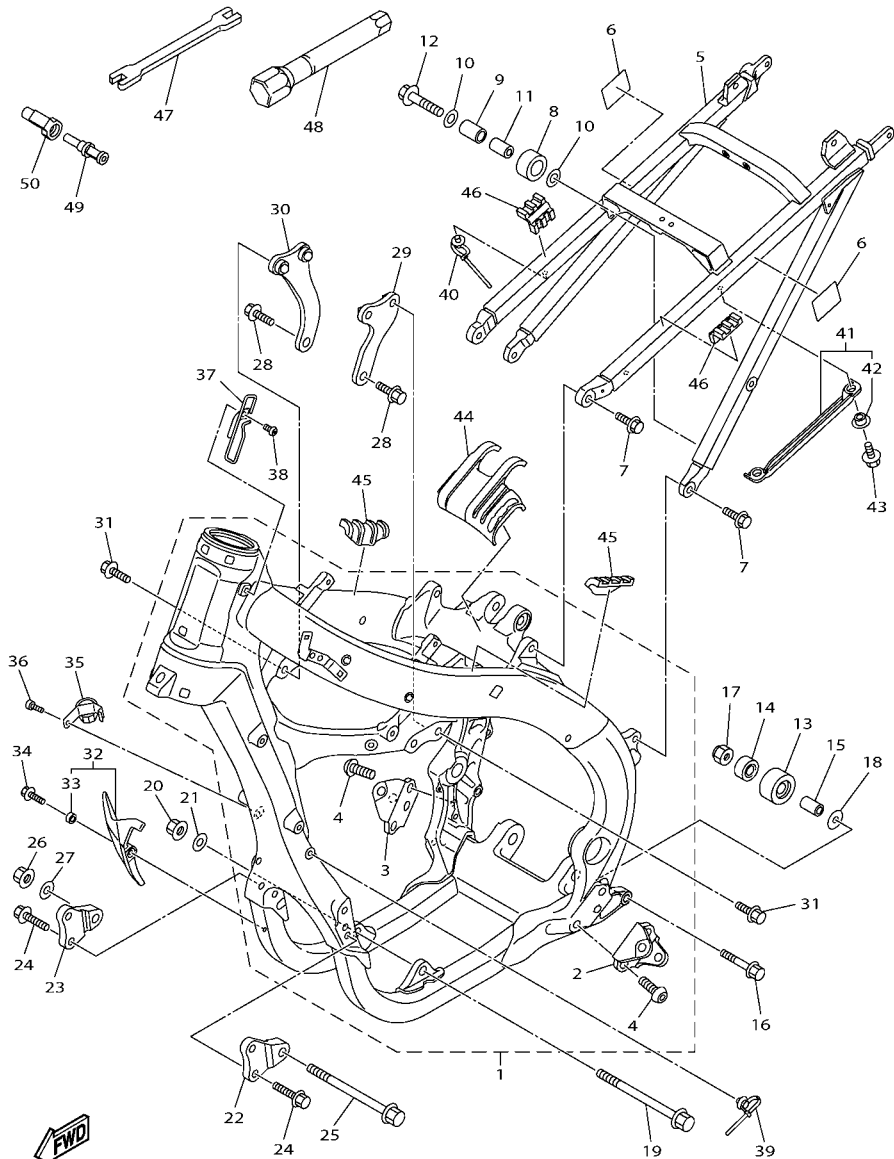

1SM1110-N190

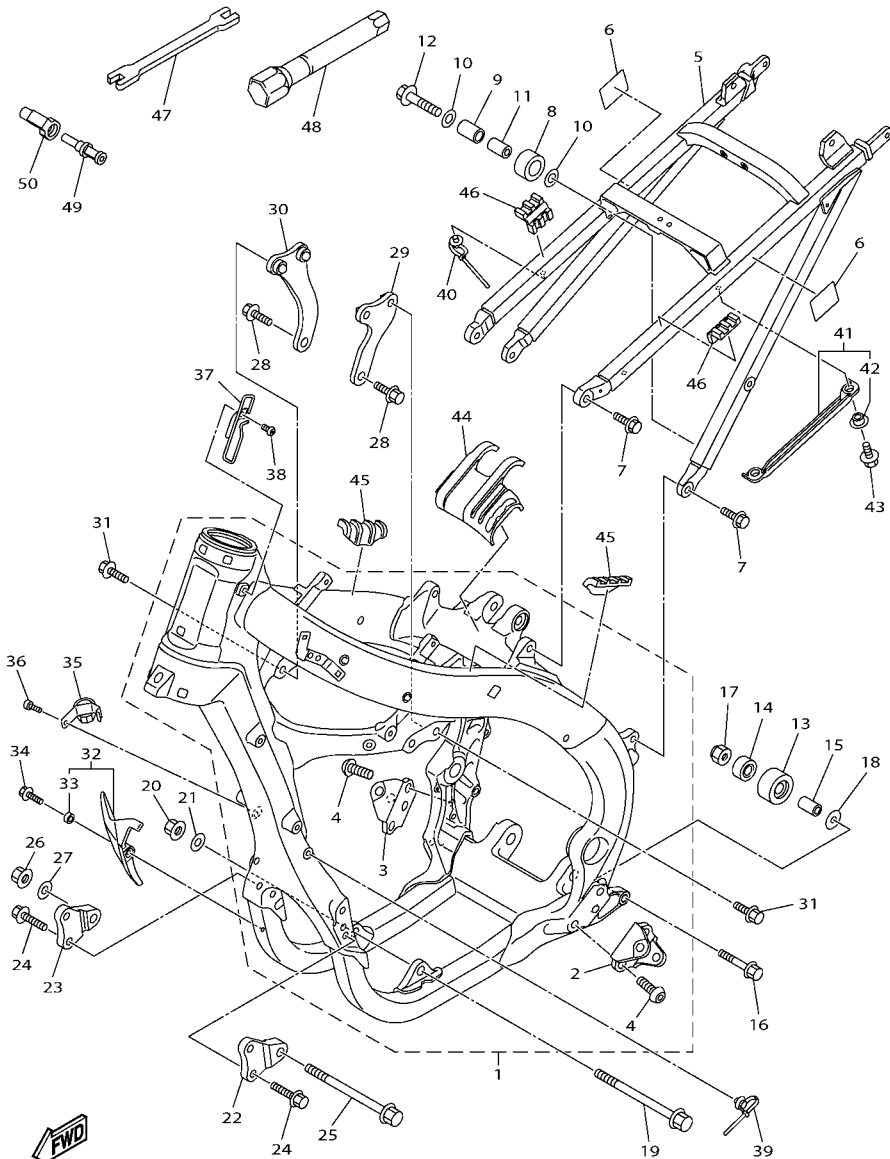

1SM1110-N190

FIG. 19 FRAME

REF. NO.	PART NO.	DESCRIPTION	1SM1	1SM2	1SM3	1SM4	REMARKS
28	90105-10189	BOLT, FLANGE	2	2	2	2	
29	1SM-21425-00	BRACKET, REAR UPPER 1	1	1	1	1	
30	1SM-21426-00	BRACKET, REAR UPPER 2	1	1	1	1	
31	90105-08143	BOLT, FLANGE	4	4	4	4	
32	1SM-21471-00	PROTECTOR, ENGINE	1	1	1	1	
33	90387-06106	.COLLAR	1	1	1	1	
34	90105-06203	BOLT, FLANGE	1	1	1	1	
35	1SM-21335-00	CLAMP, WIRE HARNESS 1	1	1	1	1	
36	91312-05008	BOLT	1	1	1	1	
37	1SL-21163-00	HOLDER, CLUTCH CABLE	1	1	1	1	
38	92012-06010	BOLT, BUTTON HEAD	1	1	1	1	
39	90464-31002	CLAMP	1	1	1	1	
40	90464-31002	CLAMP	1	1	1	1	
41	1SL-2171E-00	COVER, SIDE 5	1	1	1	1	
42	90387-065T2	.COLLAR	2	2	2	2	
43	95022-06016	BOLT, FLANGE	2	2	2	2	
44	1SL-24181-00	DAMPER, LOCATING 1	1	1	1	1	
45	33D-24182-00	DAMPER, LOCATING 2	2	2	2	2	
46	33D-24183-00	DAMPER, LOCATING 3	2	2	2	2	
47	5ET-28166-10	WRENCH, HEXAGON	1	1	1	1	
48	17D-2814F-00	BOX, SPARK PLUG	1	1	1	1	
49	18P-2467E-00	CAP	1	1	1	1	
50	18P-2464V-00	CASE, CAP	1	1	1	1	

FIG. 20 FENDER

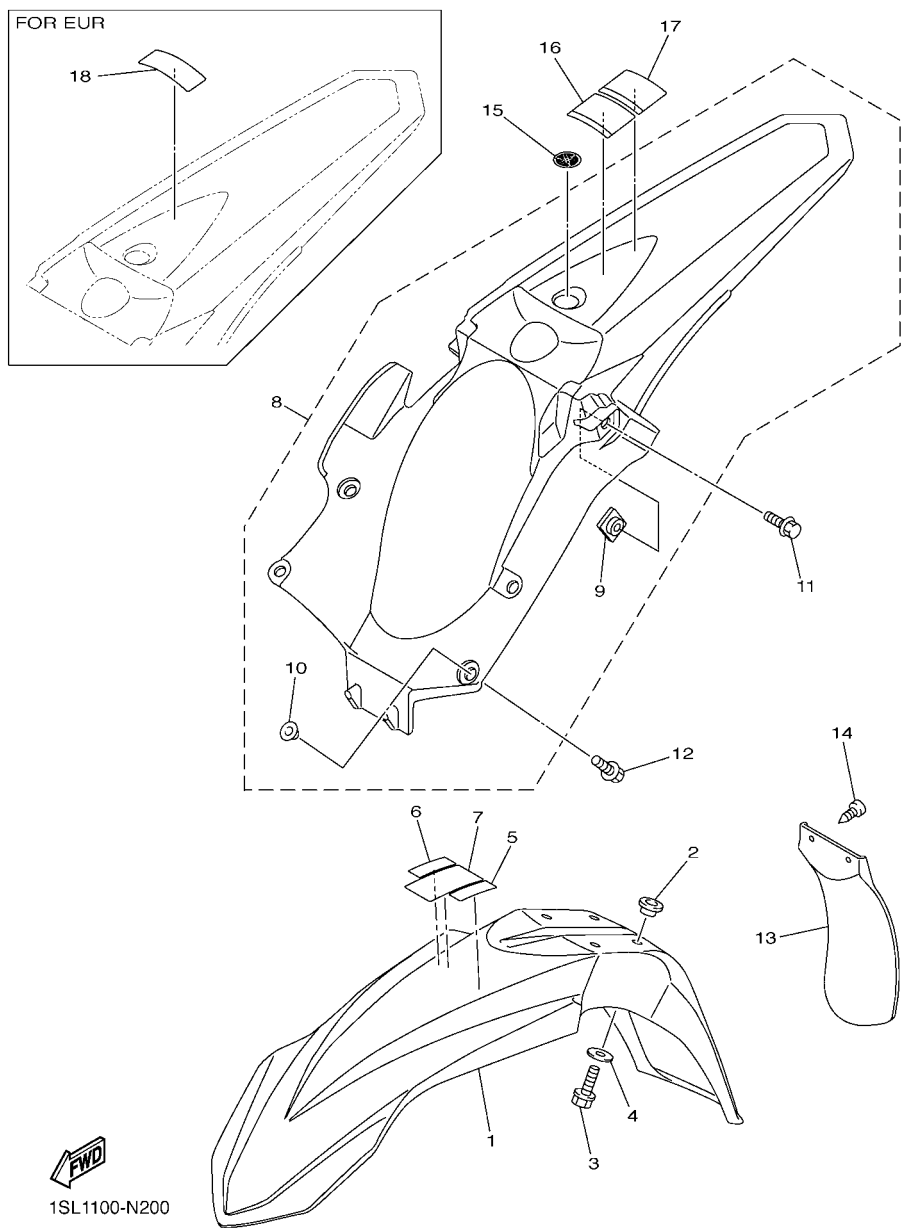

1SL1100-N200

REF. NO.	PART NO.	DESCRIPTION	1SM1	1SM2	1SM3	1SM4	REMARKS
1	17D-21511-50	FENDER, FRONT	1	1	1	1	UR FOR DPBSE
	17D-21511-60	FENDER, FRONT	1	1		1	UR FOR PWS1
2	90387-06259	COLLAR	4	4	4	4	
3	90105-06127	BOLT, FLANGE	4	4	4	4	
4	90201-06108	WASHER, PLATE	4	4	4	4	
5	3FB-2415E-02	LABEL, CAUTION	1				
	3FB-2415E-C1	LABEL, CAUTION			1		JAPANESE
6	3FB-2415E-12	LABEL, CAUTION	1				
7	4SR-2416E-00	LABEL, CAUTION CANADA	1				
8	1SL-21610-00	REAR FENDER COMP.	1	1	1	1	UR FOR DPBSE
	1SL-21610-10	REAR FENDER COMP.	1	1		1	UR FOR PWS1
9	5XE-21635-10	.NUT, REAR FENDER	2	2	2	2	
10	5BE-21749-00	.COLLAR	4	4	4	4	
11	90105-06100	BOLT, FLANGE	2	2	2	2	
12	90119-06268	BOLT, WITH WASHER	4	4	4	4	
13	17D-21642-00	GUARD, FLAP	1	1	1	1	
14	97702-60016	SCREW, TAPPING	2	2	2	2	
15	5FK-2175C-30	TUNING FORK MARK	1	1	1	1	
16	5PA-2118K-00	LABEL, CAUTION	1			1	
	5PA-2118K-20	LABEL, CAUTION			1		
17	5PA-2118K-10	LABEL, CAUTION	1				
18	5PG-2816R-00	LABEL, WARNING GENERAL INFO.		1			

FIG. 21 SIDE COVER

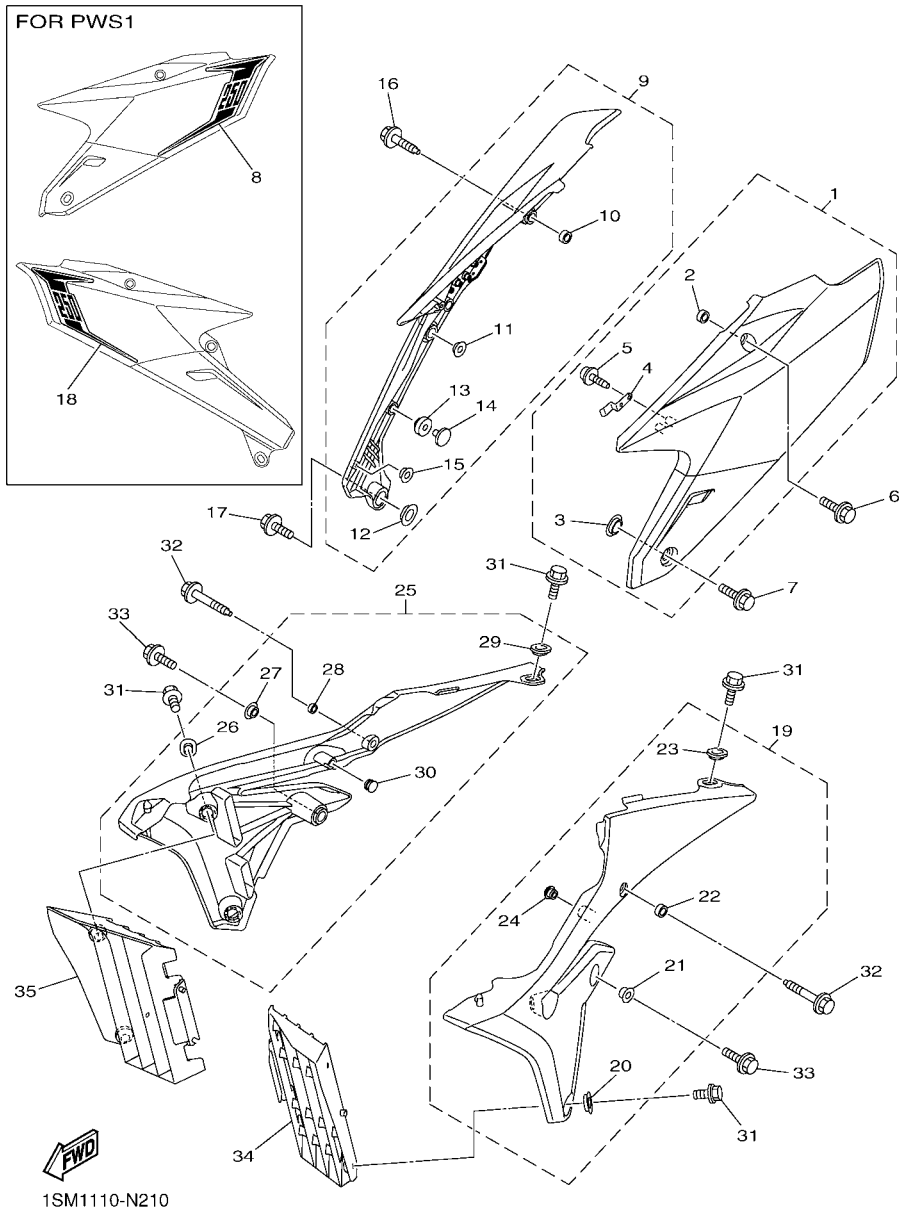

REF. NO.	PART NO.	DESCRIPTION	1SM1	1SM2	1SM3	1SM4	REMARKS
1	1SL-21710-00	SIDE COVER ASSY 1	1	1	1	1	
2	90387-08057	.COLLAR	1	1	1	1	
3	5TA-21749-00	.COLLAR	1	1	1	1	
4	1SL-2176M-00	.HOOK	1	1	1	1	
5	97702-40012	.SCREW, TAPPING	5	5	5	5	
6	90105-08230	BOLT, FLANGE	1	1	1	1	
7	90119-06096	BOLT, WITH WASHER	1	1	1	1	
8	1SM-2173E-00	GRAPHIC 1	1	1		1	FOR PWS1
9	1SL-21720-00	SIDE COVER ASSY 2	1	1	1	1	
10	90387-08057	.COLLAR	1	1	1	1	
11	5BE-21749-00	.COLLAR	1	1	1	1	
12	5TA-21749-00	.COLLAR	1	1	1	1	
13	1SL-21719-00	.GROMMET	3	3	3	3	
14	1DX-21746-00	.DAMPER	1	1	1	1	
15	90387-06M31	.COLLAR	1	1	1	1	
16	90105-08230	BOLT, FLANGE	1	1	1	1	
17	90119-06096	BOLT, WITH WASHER	2	2	2	2	
18	1SM-2173F-00	GRAPHIC 2	1	1		1	FOR PWS1
19	1SM-217R0-00	SIDE COVER ASSY 3(W/GRAPHIC)	1	1	1	1	UR FOR DPBSE
	1SL-217R0-10	SIDE COVER ASSY 3(W/GRAPHIC)	1	1		1	UR FOR PWS1
	1SL-21730-00	SIDE COVER ASSY 3(WO/GRAPHIC)	1	1	1	1	AP DPBSE
20	17D-21749-00	.COLLAR	2	2	2	2	
21	90387-11009	.COLLAR	1	1	1	1	
22	90387-06372	.COLLAR	1	1	1	1	
23	1SL-21748-00	.COLLAR	1	1	1	1	
24	90480-10068	.GROMMET	1	1	1	1	
25	1SM-217S0-00	SIDE COVER ASSY 4(W/GRAPHIC)	1	1	1	1	UR FOR DPBSE

FIG. 22 REAR ARM

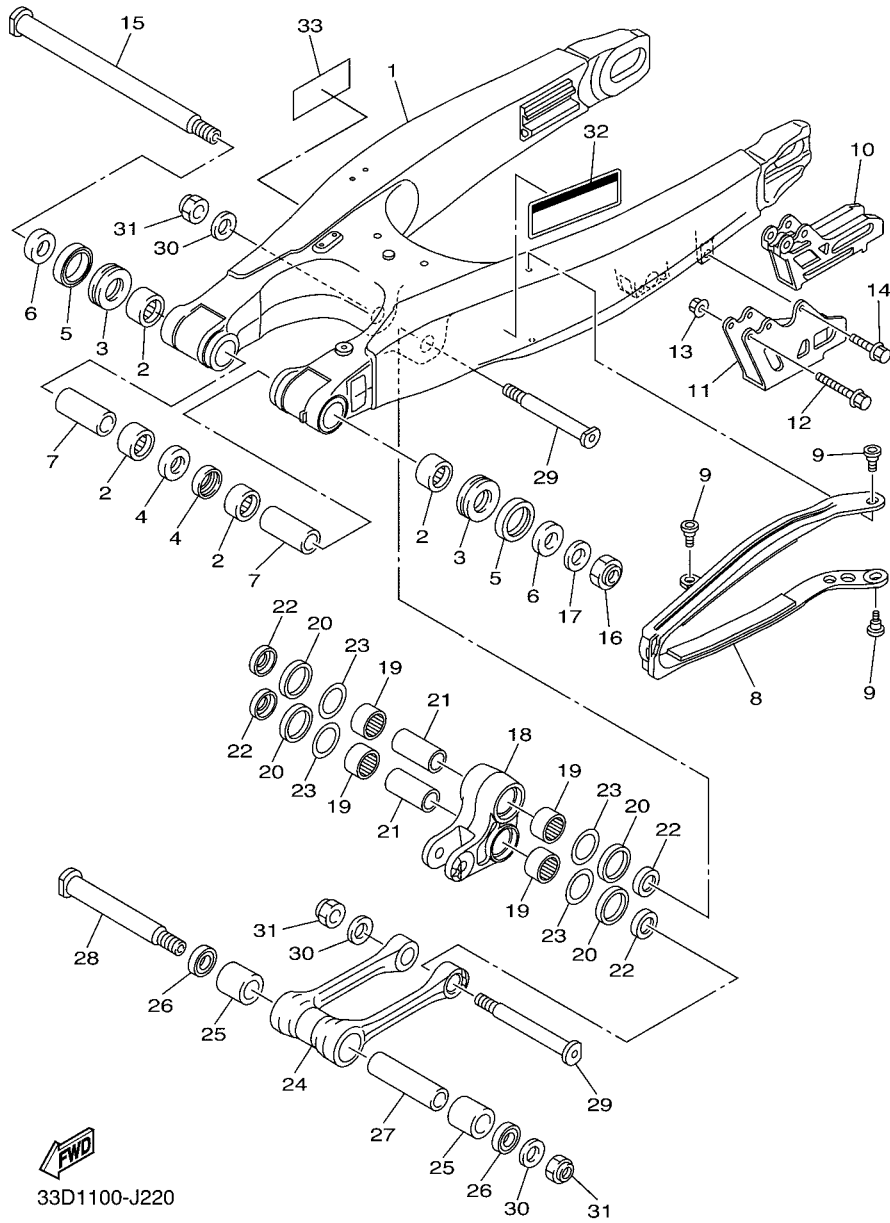

33D1100-J220

REF. NO.	PART NO.	DESCRIPTION	ISM1	ISM2	ISM3	ISM4	REMARKS
1	1SL-22110-00	REAR ARM COMP.	1	1	1	1	
2	93317-22262	BEARING	4	4	4	4	
3	93342-22217	BEARING	2	2	2	2	
4	93106-22002	OIL SEAL	2	2	2	2	
5	93109-28043	OIL SEAL	2	2	2	2	
6	90387-17016	COLLAR	2	2	2	2	
7	90387-1714S	COLLAR	2	2	2	2	
8	34P-22151-01	SEAL, GUARD	1	1	1	1	
9	1C3-22969-90	SCREW, 1	3	3	3	3	
10	2S2-22199-70	SUPPORT, CHAIN	1	1	1	1	
11	2S2-22128-70	COVER, THRUST 1	1	1	1	1	
12	90105-06104	BOLT, FLANGE	2	2	2	2	
13	95702-06500	NUT, FLANGE	2	2	2	2	
14	90105-06105	BOLT, FLANGE	1	1	1	1	
15	33D-22141-00	SHAFT, PIVOT	1	1	1	1	
16	90185-16002	NUT, SELF-LOCKING	1	1	1	1	
17	90201-16018	WASHER, PLATE	1	1	1	1	
18	17D-2217A-00	ARM, RELAY	1	1	1	1	
19	93315-32166	BEARING	4	4	4	4	
20	93109-25001	OIL SEAL	4	4	4	4	
21	90387-16026	COLLAR	2	2	2	2	
22	90209-16011	WASHER	4	4	4	4	
23	90201-21014	WASHER, PLATE	4	4	4	4	
24	33D-2217F-00	ROD, CONNECTING 1	1	1	1	1	
25	93315-32166	BEARING	2	2	2	2	
26	93109-21001	OIL SEAL	2	2	2	2	
27	90387-14016	COLLAR	1	1	1	1	

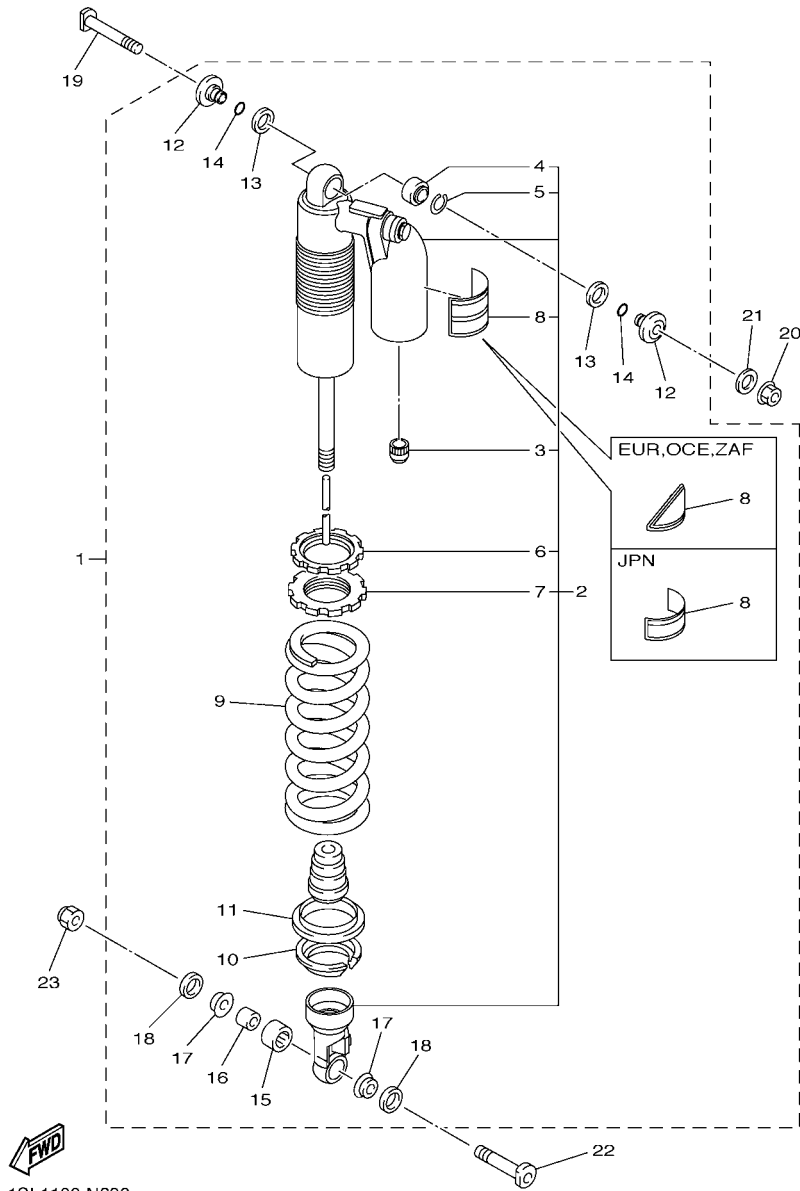

1SL1100-N230

FIG. 23 REAR SUSPENSION

REF. NO.	PART NO.	DESCRIPTION	1SM1	1SM2	1SM3	1SM4	REMARKS
1	1SM-22200-60	SHOCK ABSORBER ASSY, REAR	1				UR FOR DPBSE
	1SM-22200-70	SHOCK ABSORBER ASSY, REAR	1				UR FOR PWS1
	1SM-22200-20	SHOCK ABSORBER ASSY, REAR		1	1		UR FOR DPBSE
	1SM-22200-30	SHOCK ABSORBER ASSY, REAR		1	1		UR FOR PWS1
	1SM-22200-40	SHOCK ABSORBER ASSY, REAR			1		
2	1SM-22201-30	.DAMPER SUB ASSY	1				
	1SM-22201-10	.DAMPER SUB ASSY		1	1		
	1SM-22201-20	.DAMPER SUB ASSY			1		
3	509-23184-L0	..CAP, AIR VALVE	1	1	1	1	
4	4JX-22226-00	..BUSH, SHOCK ABSORBER LOWER	1	1	1	1	
5	5DH-23183-00	..CIRCLIP	1	1	1	1	
6	33D-22234-00	..GUIDE, SPRING 3	1	1	1	1	
7	1SL-22213-00	..SEAT, SPRING UPPER	1	1	1	1	
8	4AA-22259-70	..LABEL, WARNING	1				
	4AA-22259-40	..LABEL, WARNING		1		1	
	4AA-22259-50	..LABEL, WARNING			1		
9	1SL-22212-20	.SPRING (K=56 BLUE)	1				UR FOR DPBSE
	1SL-22212-30	.SPRING (K=56 RED)	1				UR FOR PWS1
	1SL-22212-60	.SPRING (K=54 BLUE)		1	1	1	UR FOR DPBSE
	1SL-22212-70	.SPRING (K=54 RED)		1		1	UR FOR PWS1
10	33D-22214-00	..GUIDE, SPRING 1	1	1	1	1	
11	33D-22224-00	..GUIDE, SPRING 2	1	1	1	1	
12	1C3-22253-50	..COLLAR, DISTANCE	2	2	2	2	
13	3JE-22475-00	..SEAL, DUST	2	2	2	2	
14	4EW-22474-00	..SEAL, RING	2	2	2	2	
15	5UN-22176-00	..BEARING	1	1	1	1	
16	5MV-22184-00	..BUSH	1	1	1	1	

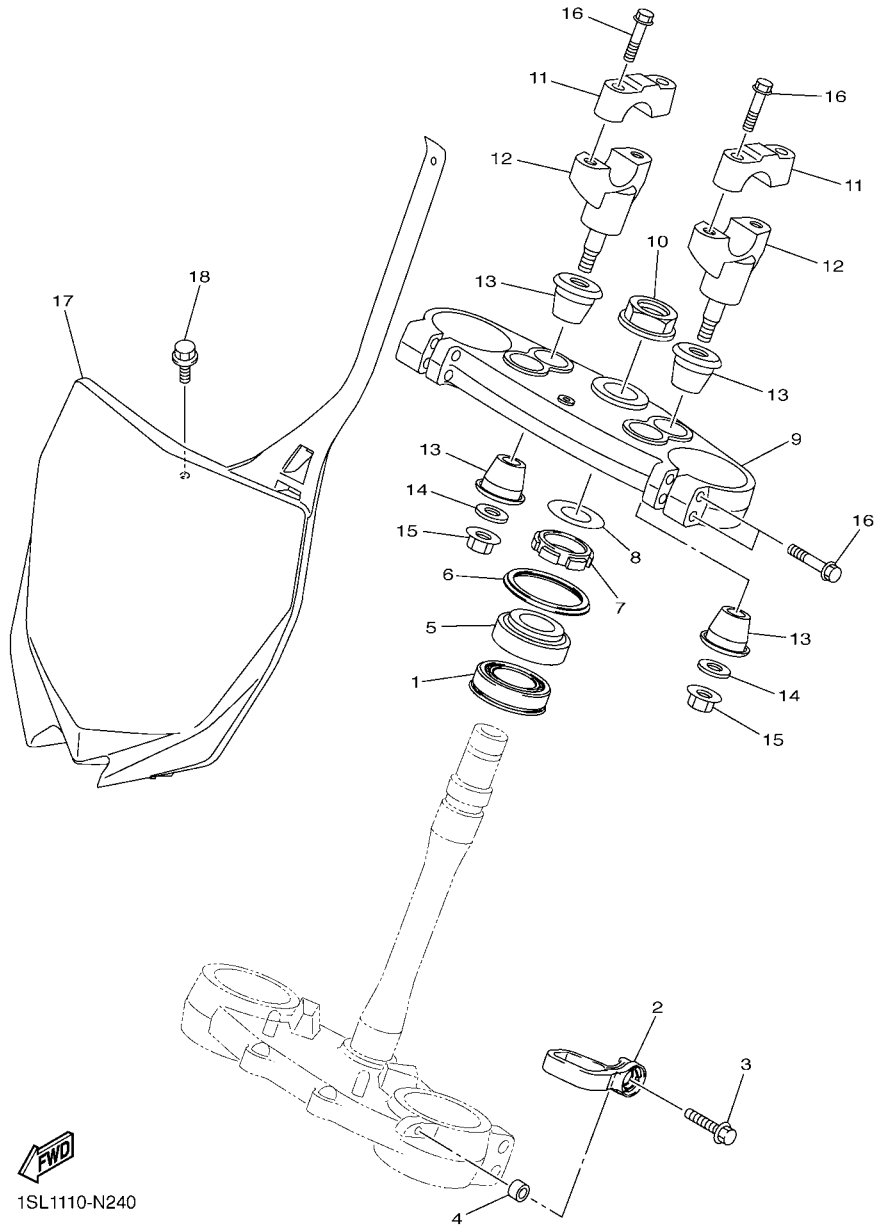

1SL1110-N240

FIG. 24 STEERING

REF. NO.	PART NO.	DESCRIPTION	ISM1	ISM2	ISM3	ISM4	REMARKS
1	93332-00081	BEARING	1	1	1	1	
2	17D-23389-50	GUIDE, CABLE	1	1	1	1	
3	90105-06170	BOLT, FLANGE	1	1	1	1	
4	90387-06105	COLLAR	1	1	1	1	
5	93332-00068	BEARING	1	1	1	1	
6	17D-23416-50	COVER, BALL RACE 2	1	1	1	1	
7	90179-28015	NUT	1	1	1	1	
8	90201-286K9	WASHER, PLATE (T1.0)	1	1	1	1	
9	1SL-23435-00	CROWN, HANDLE	1	1	1	1	
10	90179-24004	NUT	1	1	1	1	
11	18P-23441-00	HOLDER, HANDLE UPPER	2	2	2	2	
12	1SL-23442-00	HOLDER, HANDLE LOWER	2	2	2	2	
13	1SL-23434-00	HOLDER, DAMPER	4	4	4	4	
14	90201-10035	WASHER, PLATE	2	2	2	2	
15	95602-10200	NUT, U FLANGE	2	2	2	2	
16	90105-08154	BOLT, FLANGE	8	8	8	8	
17	17D-23485-50	PLATE, NUMBER	1	1	1	1	
18	90105-06064	BOLT, FLANGE	1	1	1	1	

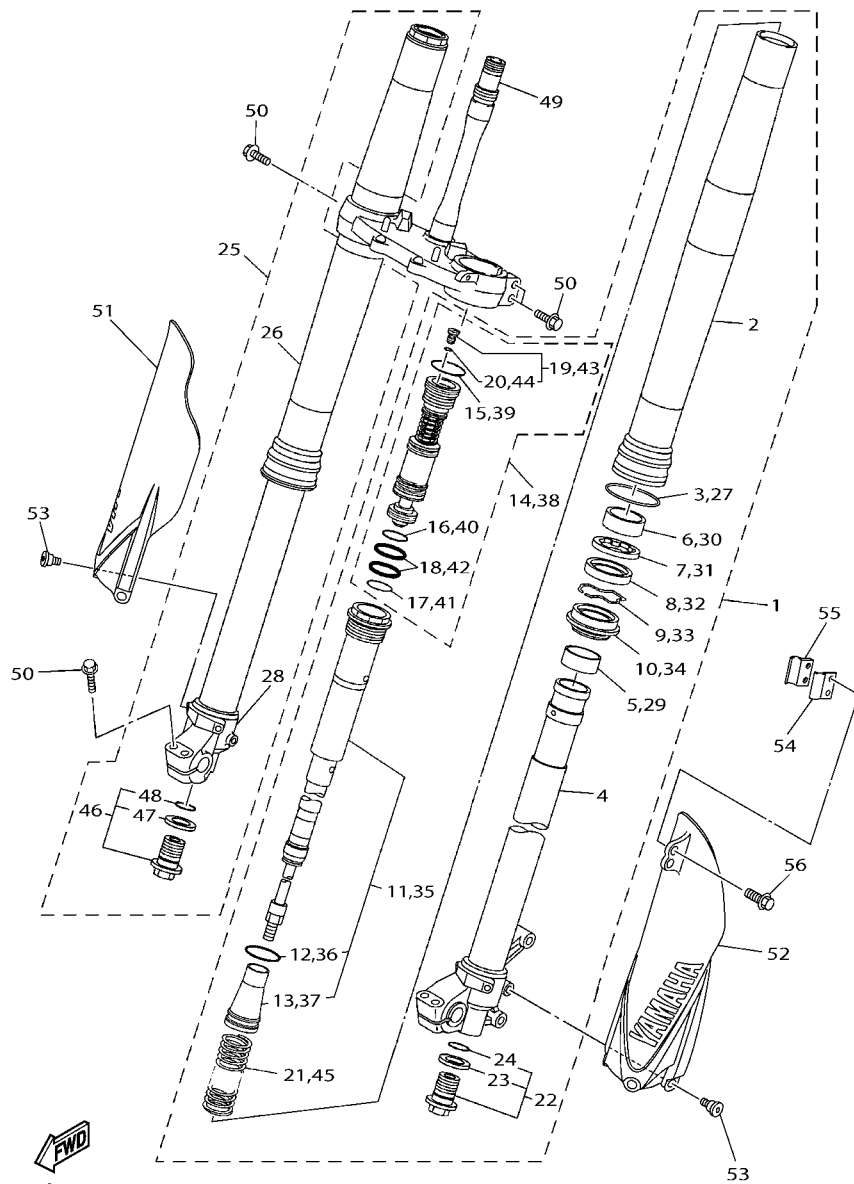

1SM1110-N250

FIG. 25 FRONT FORK

REF. NO.	PART NO.	DESCRIPTION	1SM1	1SM2	1SM3	1SM4	REMARKS
1	1SM-23102-00	FRONT FORK ASSY (L.H)	1				
	1SM-23102-10	FRONT FORK ASSY (L.H)		1	1	1	
2	33D-23136-00	.TUBE, OUTER	1	1	1	1	
3	17D-23153-00	.RING, SNAP	1	1	1	1	
4	1SL-23120-00	.INNER TUBE COMP. (L.H.)	1	1	1	1	
5	5XE-23171-L0	.PISTON, FRONT FORK	1	1	1	1	
6	5XE-23125-L0	.METAL, SLIDE 1	1	1	1	1	
7	5XC-23146-10	.WASHER, OIL SEAL	1	1	1	1	
8	17D-23145-00	.OIL SEAL	1	1	1	1	
9	5XE-23153-L0	.RING, SNAP	1	1	1	1	
10	5XE-23144-L0	.SEAL, DUST	1	1	1	1	
11	1SM-23170-00	.CYLINDER COMP., FRONT FORK	1				
	1SM-23170-10	.CYLINDER COMP., FRONT FORK		1	1	1	
12	1C3-23147-L0	..O-RING	1	1	1	1	
13	17D-23142-00	..SEAT, SPRING UPPER	1	1	1	1	
14	1SM-2316A-00	.VALVE COMP.	1				
	1SM-2316A-10	.VALVE COMP.		1	1	1	
15	1C3-23188-L0	..O-RING	1	1	1	1	
16	1C3-23188-N0	..O-RING	1	1	1	1	
17	1C3-23188-P0	..O-RING	1	1	1	1	
18	1AE-23147-00	..O-RING	2	2	2	2	
19	1C3-23190-L0	..AIR VALVE COMP.	1	1	1	1	
20	1C3-23188-R0	..O-RING	1	1	1	1	
21	1SL-23141-10	.SPRING, FRONT FORK	1				
	1SM-23141-00	.SPRING, FRONT FORK		1	1	1	
22	5XC-23111-00	.BOLT, CAP	1	1	1	1	
23	2HH-23158-L0	..GASKET	1	1	1	1	

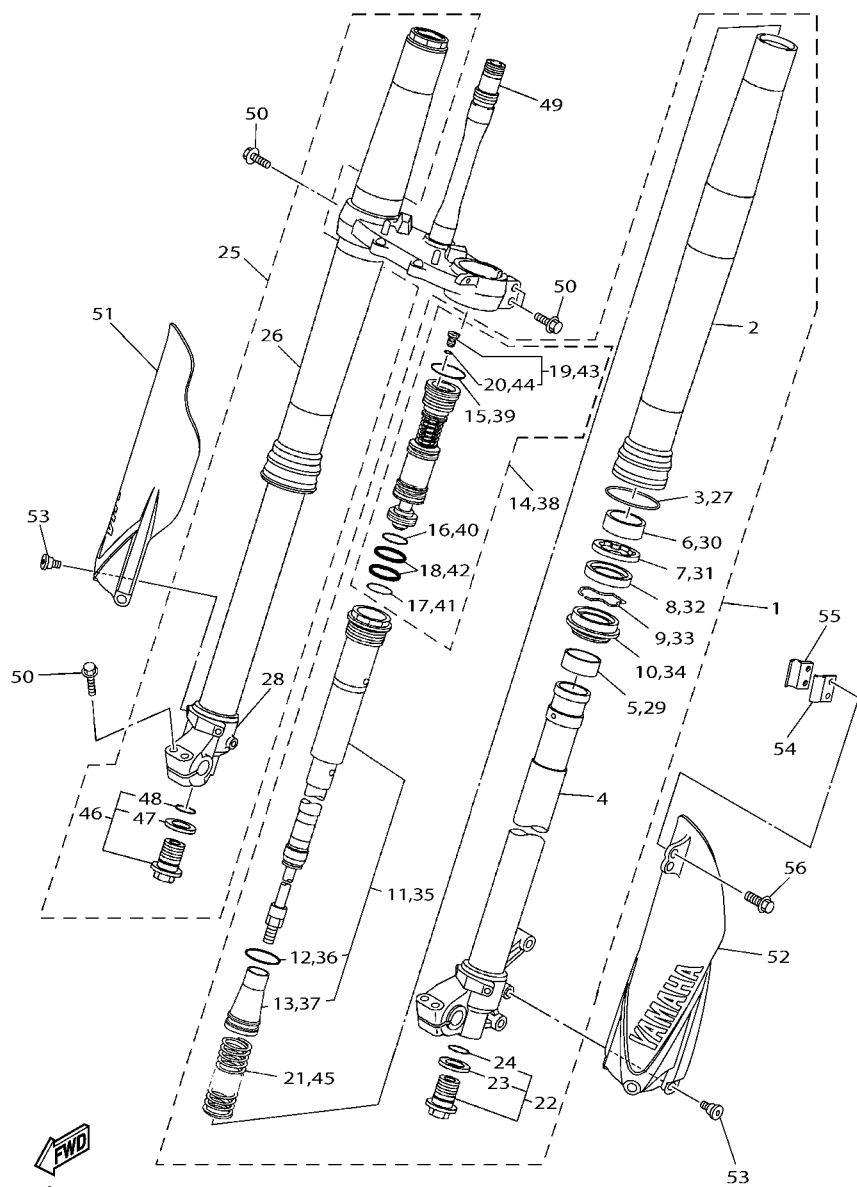

1SM1110-N250

FIG. 25 FRONT FORK

REF. NO.	PART NO.	DESCRIPTION	1SM1	1SM2	1SM3	1SM4	REMARKS
24	276-23114-00	..GASKET	1	1	1	1	
25	1SM-23103-00	FRONT FORK ASSY (R.H)	1				
	1SM-23103-10	FRONT FORK ASSY (R.H)		1	1	1	
26	33D-23136-00	.TUBE, OUTER	1	1	1	1	
27	17D-23153-00	.RING, SNAP	1	1	1	1	
28	1SL-23110-00	..INNER TUBE COMP. (R.H.)	1	1	1	1	
29	5XE-23171-L0	.PISTON, FRONT FORK	1	1	1	1	
30	5XE-23125-L0	.METAL, SLIDE 1	1	1	1	1	
31	5XC-23146-10	.WASHER, OIL SEAL	1	1	1	1	
32	17D-23145-00	.OIL SEAL	1	1	1	1	
33	5XE-23153-L0	.RING, SNAP	1	1	1	1	
34	5XE-23144-L0	.SEAL, DUST	1	1	1	1	
35	1SM-23170-00	.CYLINDER COMP., FRONT FORK	1				
	1SM-23170-10	.CYLINDER COMP., FRONT FORK		1	1	1	
36	1C3-23147-L0	..O-RING	1	1	1	1	
37	17D-23142-00	..SEAT, SPRING UPPER	1	1	1	1	
38	1SM-2316A-00	.VALVE COMP.	1				
	1SM-2316A-10	.VALVE COMP.		1	1	1	
39	1C3-23188-L0	..O-RING	1	1	1	1	
40	1C3-23188-N0	..O-RING	1	1	1	1	
41	1C3-23188-P0	..O-RING	1	1	1	1	
42	1AE-23147-00	..O-RING	2	2	2	2	
43	1C3-23190-L0	..AIR VALVE COMP.	1	1	1	1	
44	1C3-23188-R0	..O-RING	1	1	1	1	
45	1SL-23141-10	.SPRING, FRONT FORK	1				
	1SM-23141-00	.SPRING, FRONT FORK		1	1	1	
46	5XC-23111-00	.BOLT, CAP	1	1	1	1	

FIG. 26 FUEL TANK

REF. NO.	PART NO.	DESCRIPTION	1SM1	1SM2	1SM3	1SM4	REMARKS
1	1SL-24110-00	FUEL TANK COMP.	1	1	1	1	
2	1S4-2414J-00	DAMPER, PLATE 2	3	3	3	3	
3	1SL-24188-00	MOLD, FUEL TANK	1	1	1	1	
4	1SL-24610-00	CAP ASSY	1	1	1	1	
5	90445-09008	HOSE (L470)	1	1	1	1	
6	1SL-24115-00	STAY, FUEL TANK 1	2	2	2	2	
7	90105-06170	BOLT, FLANGE	4	4	4	4	
8	90387-06091	COLLAR	2	2	2	2	
9	90480-18549	GROMMET	2	2	2	2	
10	1SL-2419A-00	HOLDER	1	1	1	1	
11	90105-06170	BOLT, FLANGE	2	2	2	2	
12	90387-066Y6	COLLAR	1	1	1	1	
13	90480-10289	GROMMET	1	1	1	1	
14	95022-06020	BOLT, FLANGE	1	1	1	1	
15	33D-13907-00	FUEL PUMP COMP.	1	1	1	1	
16	33D-24486-00	O-RING	1	1	1	1	
17	33D-24491-00	BRACKET, FUEL PUMP	1	1	1	1	
18	90110-05058	BOLT, HEXAGON SOCKET HEAD	6	6	6	6	
19	1SM-13971-00	PIPE, FUEL 1	1	1	1	1	
20	33D-24135-00	CLAMP 1	1	1	1	1	
21	4EW-2412F-00	BRACKET, SEAT	1	1	1	1	
22	98707-06025	SCREW, FLAT HEAD	1	1	1	1	
23	90111-06149	BOLT, HEX. SOCKET BUTTON	2	2	2	2	
24	90387-06284	COLLAR	2	2	2	2	

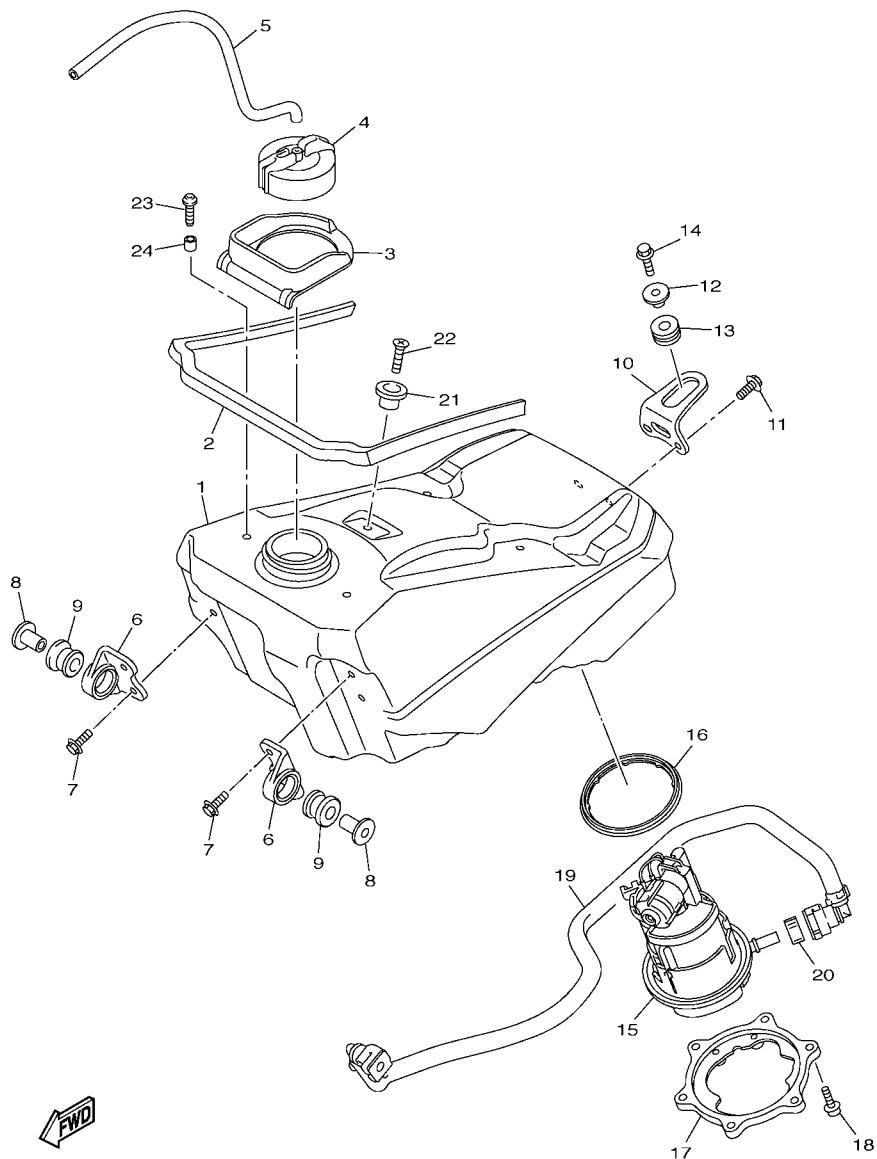

1SL1110-N260

FIG. 28 FRONT WHEEL

REF. NO.	PART NO.	DESCRIPTION	ISM1	ISM2	ISM3	ISM4	REMARKS
1	1SL-25111-00	HUB, FRONT	1	1	1	1	
2	93306-97203	BEARING	2	2	2	2	
3	1SL-25117-00	SPACER, BEARING	1	1	1	1	
4	93102-30014	OIL SEAL	2	2	2	2	
5	94416-21034	RIM (1.60-21)	1	1	1	1	UR FOR DPBSE
	94416-21045	RIM (1.60-21)	1	1		1	UR FOR PWS1
6	17D-2531B-00	.EMBLEM, WHEEL	2	2		2	FOR PWS1
7	5NY-25104-00	SPOKE SET, FRONT	1	1	1	1	
8	5NY-25196-00	.SPOKE, INNER 1			36		
9	56A-25195-00	.NIPPLE, SPOKE			36		
10	94108-21027	TIRE (80/100-21 51M)	1			1	BRIDGESTONE
	*	TIRE (80/100-21 51R MST)		1			LM PIRELLI
	*	TIRE (80/100-21 51M MX51FA)			1		LM DUNLOP
11	94209-21229	TUBE (80/100-21 M/C TR4)	1			1	BRIDGESTONE
	*	TUBE (80/100-21)			1		LM PIRELLI
	*	TUBE (80/100-21 M/C TR4)				1	LM DUNLOP
12	94330-21084	BAND,RIM (1.60-21)	1			1	BRIDGESTONE
	*	BAND, RIM (80/100-21)			1		LM PIRELLI
	*	BAND, RIM (22-21)				1	LM DUNLOP
13	5SF-25394-00	SPACER, BEAD	1	1	1	1	
14	1SL-25181-00	AXLE, WHEEL	1	1	1	1	
15	1SL-25183-00	COLLAR, WHEEL	1	1	1	1	
16	1SL-25186-00	COLLAR, WHEEL	1	1	1	1	
17	90179-18011	NUT	1	1	1	1	

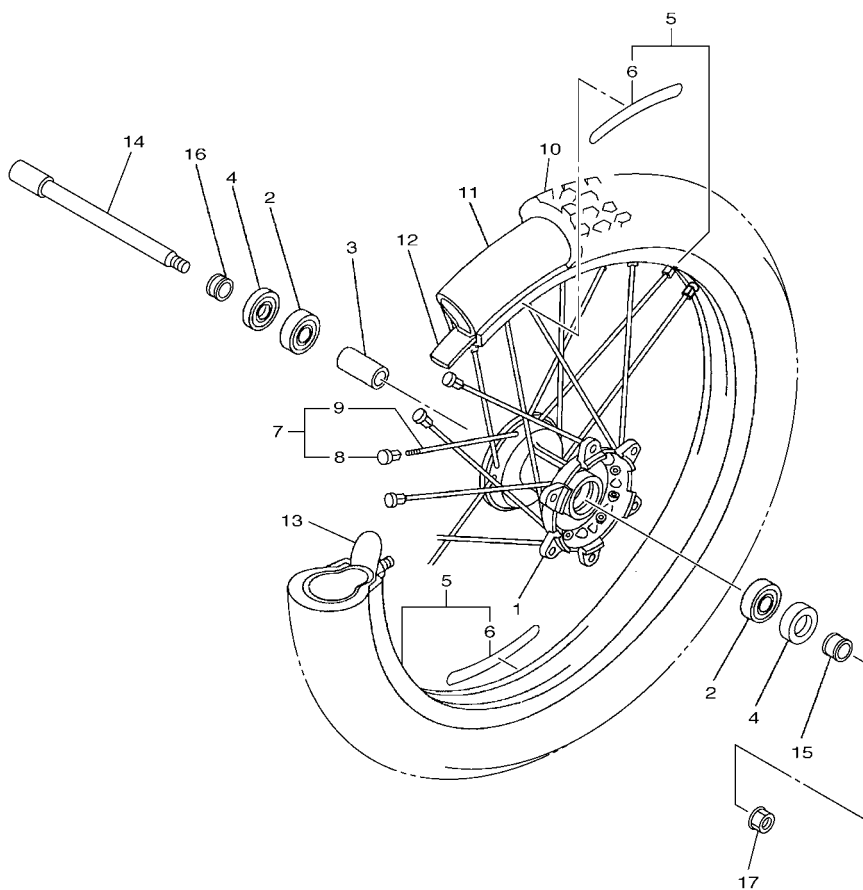

1SL1100-N280

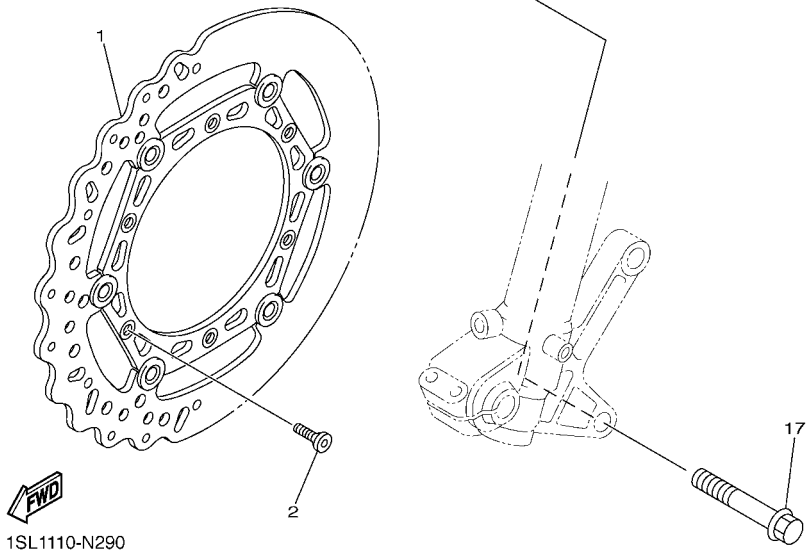
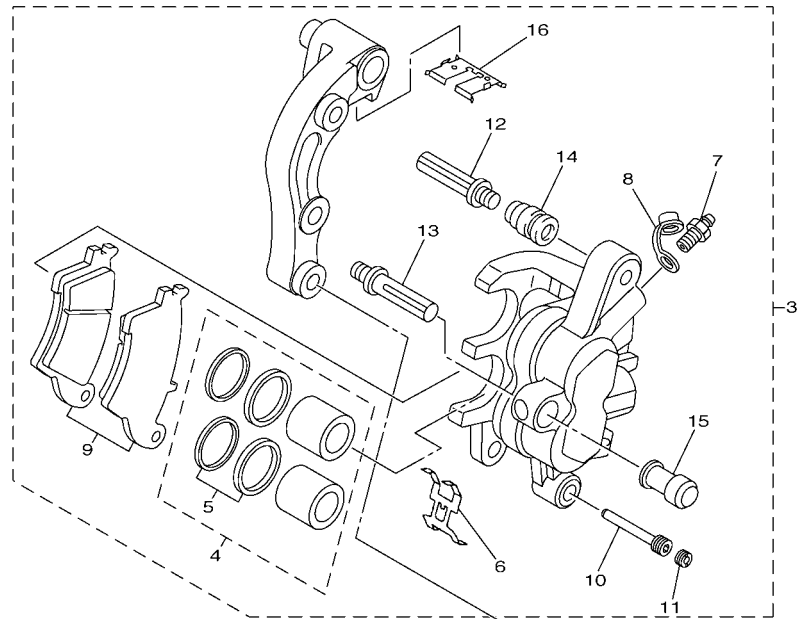
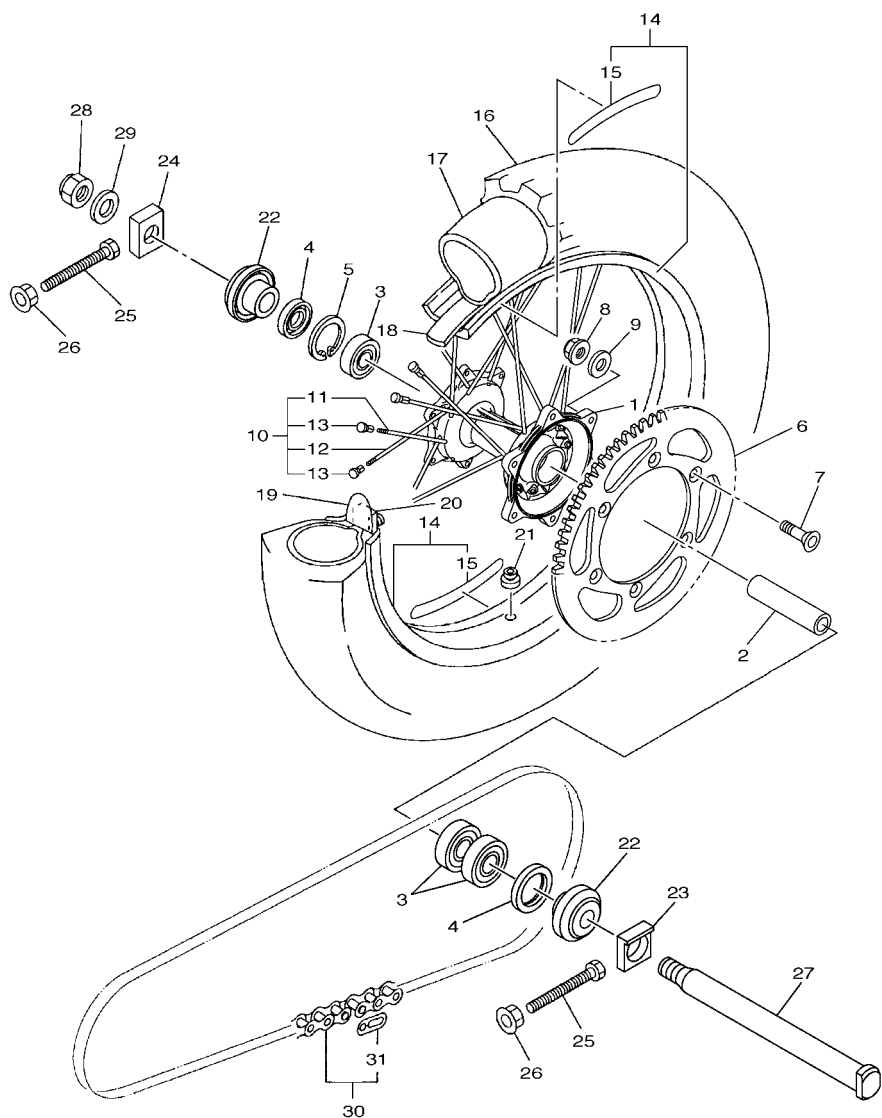

FIG. 29 FRONT BRAKE CALIPER

REF. NO.	PART NO.	DESCRIPTION	ISM1	ISM2	ISM3	ISM4	REMARKS
1	5XC-2581T-G0	DISK BRAKE ASSY	1	1	1	1	
2	90151-06051	SCREW, COUNTERSUNK	6	6	6	6	
3	5XC-2580T-G0	CALIPER ASSY (LEFT)	1	1	1	1	
4	5XC-W0057-00	.PISTON ASSY, CALIPER	1	1	1	1	
5	5KM-W0047-10	..CALIPER SEAL KIT	1	1	1	1	
6	5DH-25919-00	.SUPPORT, PAD	1	1	1	1	
7	1UY-25824-51	.SCREW, BLEED	1	1	1	1	
8	1UY-25825-51	.CAP	1	1	1	1	
9	5XC-W0045-00	.BRAKE PAD KIT	1	1	1	1	
10	5DH-25933-00	.PIN, PAD	1	1	1	1	
11	5DH-25916-00	.PLUG	1	1	1	1	
12	3SP-25926-51	.BOLT	1	1	1	1	
13	3SP-25914-51	.PIN, SLIDE	1	1	1	1	
14	3JD-25917-00	.BOOT, CALIPER	1	1	1	1	
15	1UY-25937-51	.BOOT 2	1	1	1	1	
16	5XC-25849-G0	.RETAINER, CALIPER	1	1	1	1	
17	90105-08137	BOLT, FLANGE	2	2	2	2	

FIG. 30 REAR WHEEL

REF. NO.	PART NO.	DESCRIPTION	ISM1	ISM2	ISM3	ISM4	REMARKS
1	17D-25311-00	HUB, REAR	1	1	1	1	
2	17D-25317-00	SPACER, BEARING	1	1	1	1	
3	93306-90510	BEARING	3	3	3	3	
4	93102-32337	OIL SEAL	2	2	2	2	
5	99009-42700	CIRCLIP	1	1	1	1	
6	17D-25450-50	SPROCKET, DRIVEN (50T)	1	1	1	1	STD
	17D-25447-50	SPROCKET, DRIVEN (47T)	1	1	1	1	AP
	17D-25448-50	SPROCKET, DRIVEN (48T)	1	1	1	1	AP
	17D-25449-50	SPROCKET, DRIVEN (49T)	1	1	1	1	AP
	17D-25451-50	SPROCKET, DRIVEN (51T)	1	1	1	1	AP
	17D-25452-50	SPROCKET, DRIVEN (52T)	1	1	1	1	AP
7	90109-08078	BOLT	6	6	6	6	
8	90185-08008	NUT, SELF-LOCKING	6	6	6	6	
9	90201-08048	WASHER, PLATE	6	6	6	6	
10	34P-25304-00	SPOKE SET, REAR	1	1	1	1	
11	34P-25396-00	.SPOKE, INNER 2			18		
12	34P-25397-00	.SPOKE, OUTER 2			18		
13	5ET-25395-00	.NIPPLE, SPOKE			36		
14	94418-19026	RIM (1.85-19)	1	1	1	1	UR FOR DPBSE
	94418-19036	RIM (1.85-19)	1	1		1	UR FOR PWS1
15	17D-2531B-00	.EMBLEM, WHEEL	2	2		2	FOR PWS1
16	94110-19019	TIRE (100/90-19 57M M404)	1			1	BRIDGESTONE
*		TIRE (100/90-19 57M NHS)			1		LM PIRELLI
*		TIRE (100/90-19 57M MX51G)			1		LM DUNLOP
17	94210-19222	TUBE (100/90-19 M/C TR4)	1			1	BRIDGESTONE
*		TUBE (110/90-19)			1		LM PIRELLI
*		TUBE (100/90-19 M/C TR4 BTL)				1	LM DUNLOP



1SL1100-N300

FIG. 30 REAR WHEEL

REF. NO.	PART NO.	DESCRIPTION	ISM1	ISM2	ISM3	ISM4	REMARKS
18	94316-19156	BAND, RIM (1.85-19)	1			1	BRIDGESTONE
	*	BAND, RIM (3.50-18)		1			LM METZELER
	*	BAND, RIM (22-19)			1		LM DUNLOP
19	4XM-25394-00	SPACER, BEAD	1	1	1	1	
20	4XM-25364-00	DAMPER	1	1	1	1	
21	90480-08608	GROMMET	1	1	1	1	
22	17D-2530S-00	COLLAR ASSY	2	2	2	2	
23	1SL-25388-00	PULLER, CHAIN 1	1	1	1	1	
24	1SL-25389-00	PULLER, CHAIN 2	1	1	1	1	
25	90101-08006	BOLT	2	2	2	2	
26	90179-08019	NUT	2	2	2	2	
27	17D-25381-00	AXLE, WHEEL	1	1	1	1	
28	90185-22011	NUT, SELF-LOCKING	1	1	1	1	
29	90201-22023	WASHER, PLATE	1	1	1	1	
30	9Y581-92113	CHAIN (DID520DMA2 SDH 114LL)	1	1	1	1	UR FOR DPBSE
	9Y582-28113	CHAIN (DID520DMA2-114LL)	1	1		1	UR FOR PWS1
31	94681-68001	.JOINT,CHAIN (DID 520DM-RJ)	1	1	1	1	UR FOR DPBSE
	94682-28001	.JOINT, CHAIN(DID520DM G&B-RJ)	1	1		1	UR FOR PWS1

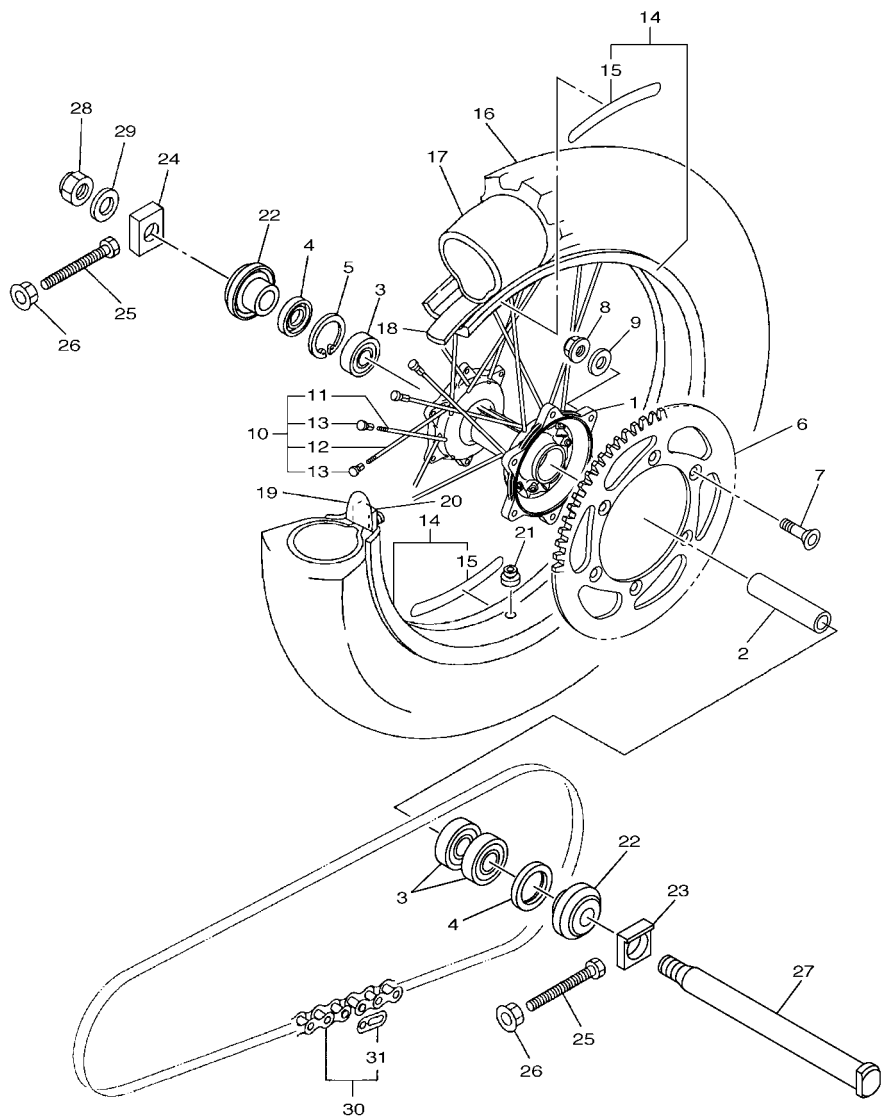

1SL1100-N300

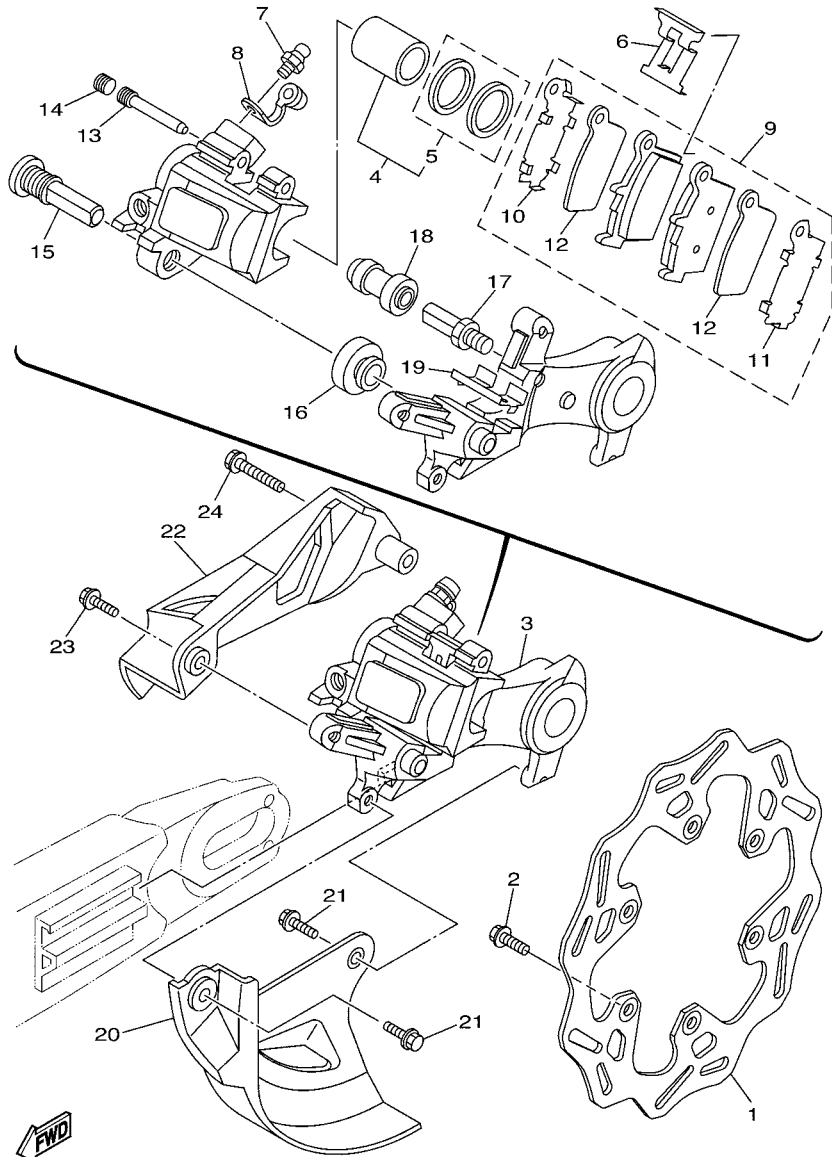

33DD110-M310

FIG. 31 REAR BRAKE CALIPER

REF. NO.	PART NO.	DESCRIPTION	ISM1	ISM2	ISM3	ISM4	REMARKS
1	2S2-2582W-70	DISK, REAR BRAKE 2	1	1	1	1	
2	90105-06156	BOLT, FLANGE	6	6	6	6	
3	17D-2580W-01	CALIPER ASSY, REAR 2	1		1	1	
	17D-2580W-11	CALIPER ASSY, REAR 2		1			
4	5UN-W0057-50	.PISTON ASSY, CALIPER	1	1	1	1	
5	5UN-W0047-50	..CALIPER SEAL KIT	1	1	1	1	
6	5DH-25919-50	.SUPPORT, PAD	1	1	1	1	
7	1UY-25824-51	.SCREW, BLEED	1	1	1	1	
8	1UY-25825-51	.CAP	1	1	1	1	
9	1C3-W0046-50	.BRAKE PAD KIT 2	1		1	1	
	1C3-W0046-B0	.BRAKE PAD KIT 2		1			
10	5UN-25828-60	..SHIM, CALIPER	1	1	1	1	
11	5UN-25827-60	..SHIM, CALIPER	1	1	1	1	
12	5UN-22898-60	..INSULATOR, HEAT	2	2	2	2	
13	8CR-25924-00	.PIN, PAD	1	1	1	1	
14	5DH-25916-00	.PLUG	1	1	1	1	
15	5DH-25914-50	.PIN, SLIDE	1	1	1	1	
16	3JD-25917-00	.BOOT, CALIPER	1	1	1	1	
17	5UN-25914-00	.PIN, SLIDE	1	1	1	1	
18	1UY-25937-51	.BOOT 2	1	1	1	1	
19	5UN-25913-00	.RETAINER	1	1	1	1	
20	17D-25718-50	PROTECTOR, DISK BRAKE	1	1	1	1	
21	90105-06110	BOLT, FLANGE	2	2	2	2	
22	17D-27491-50	PROTECTOR	1	1	1	1	
23	90105-06110	BOLT, FLANGE	1	1	1	1	
24	90105-06111	BOLT, FLANGE	1	1	1	1	

FIG. 32 STEERING HANDLE & CABLE

REF. NO.	PART NO.	DESCRIPTION	1SM1	1SM2	1SM3	1SM4	REMARKS
1	17D-26111-H0	HANDLEBAR	1	1	1	1	
2	4GY-26241-00	GRIP	1	1	1	1	
3	1SL-26240-00	GRIP ASSY	1	1	1	1	
4	4GY-26242-00	.GRIP (RIGHT)	1	1	1	1	
5	3Y1-26249-00	.RING, LEAF	1	1	1	1	
6	5BE-26281-01	CAP, GRIP UPPER	1	1	1	1	
7	5BE-26282-00	CAP, GRIP UNDER	1	1	1	1	
8	98507-05020	SCREW, PAN HEAD	2	2	2	2	
9	5SF-26287-11	COVER, CAP GRIP	1	1	1	1	
10	1SM-26302-00	THROTTLE CABLE ASSY	1	1	1	1	
11	1SM-26335-00	CABLE, CLUTCH	1	1	1	1	
12	34P-26342-00	BOOT, CABLE	1	1	1	1	
13	90387-225N2	COLLAR	1	1	1	1	
14	17D-26124-00	PROTECTOR, HANDLEBAR	1	1	1	1	
15	17D-26143-H0	COVER, HANDLE UPPER 1	1	1	1	1	

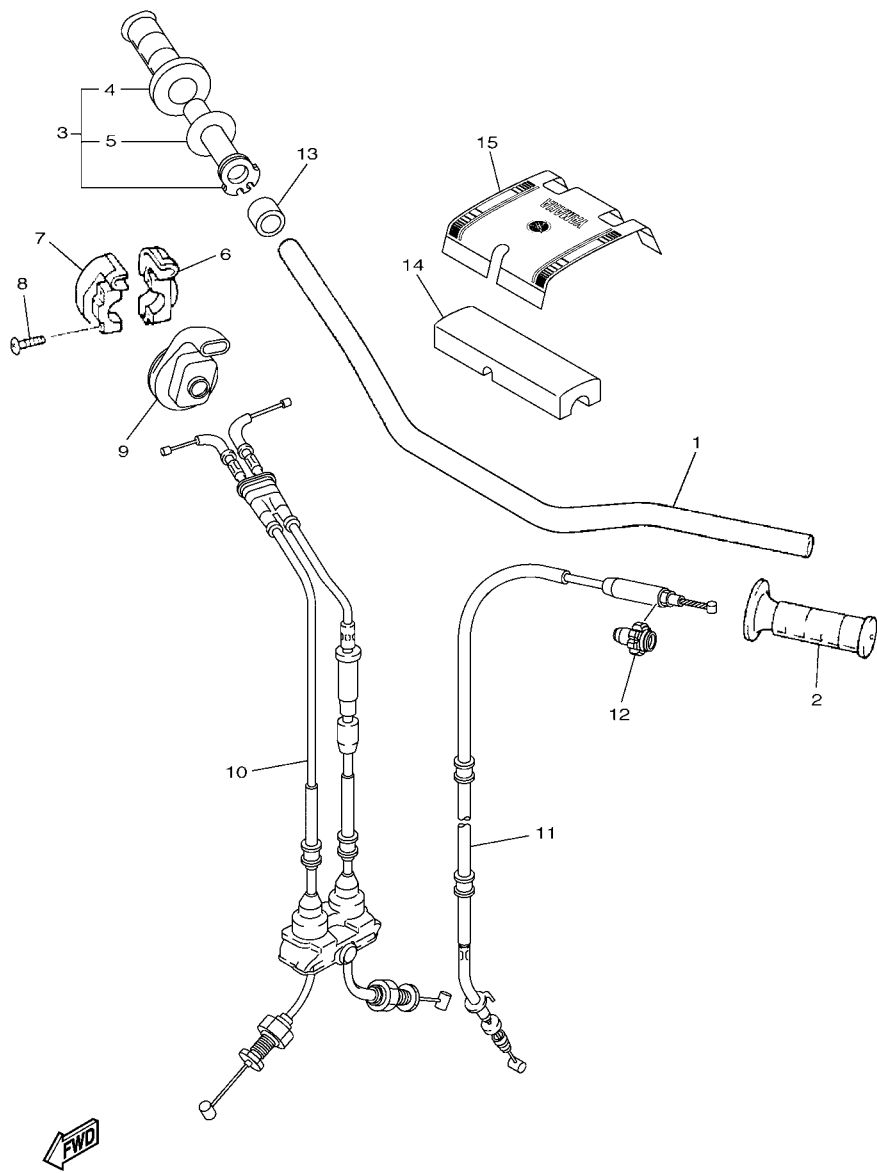

1SL1110-N320

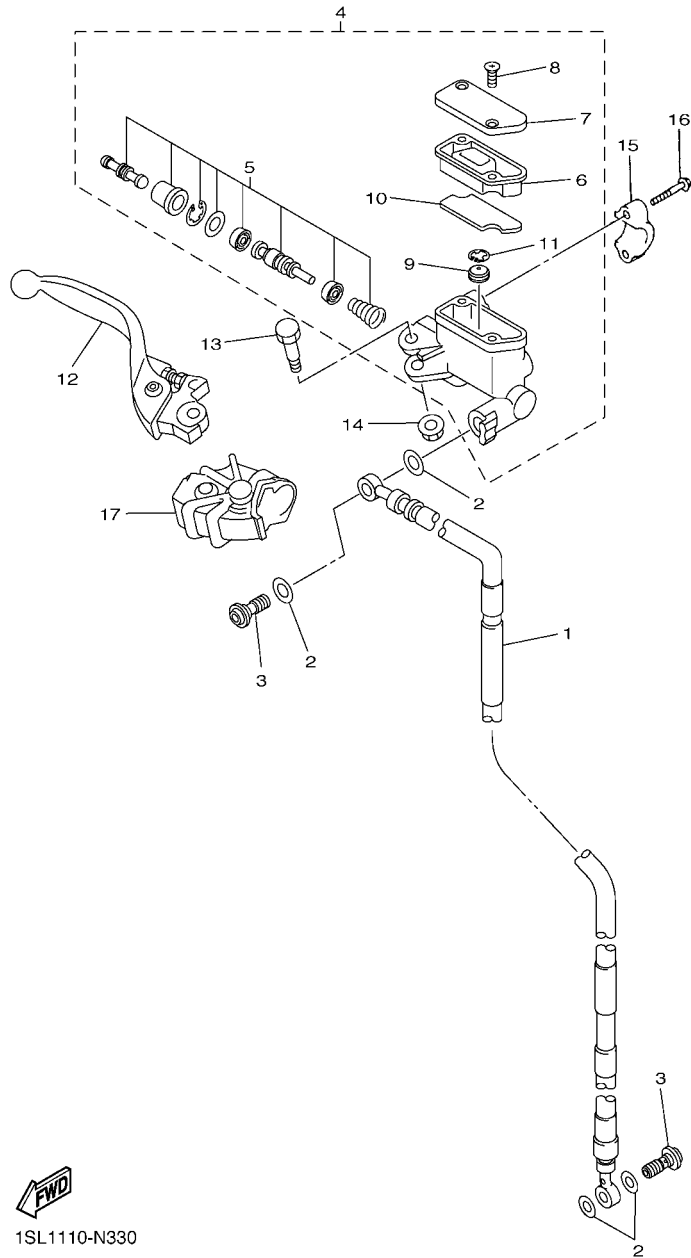

1SL1110-N330

FIG. 33 FRONT MASTER CYLINDER

REF. NO.	PART NO.	DESCRIPTION	1SM1	1SM2	1SM3	1SM4	REMARKS
1	1SL-25872-00	HOSE, BRAKE 1	1	1	1	1	
2	90430-10005	GASKET	4	4	4	4	
3	90401-10172	BOLT, UNION	2	2	2	2	
4	5XC-W2587-00	MASTER CYLINDER SUB ASSY	1	1	1	1	
5	5XC-W0041-00	.CYLINDER KIT, MASTER	1	1	1	1	
6	5XC-25854-G0	.DIAPHRAGM, RESERVOIR	1	1	1	1	
7	5XC-25852-G0	.CAP, RESERVOIR	1	1	1	1	
8	98706-04012	.SCREW, FLAT HEAD	2	2	2	2	
9	5CG-25715-00	.SEPARATOR ASSY	1	1	1	1	
10	5CG-2585G-00	.CIRCLIP	1	1	1	1	
11	5XC-25853-G0	.FLOAT, RESERVOIR	1	1	1	1	
12	5XC-83922-L0	LEVER 2	1	1	1	1	
13	5MV-2589F-00	BOLT, LEVER	1	1	1	1	
14	95701-06500	NUT, WITH WASHER	1	1	1	1	
15	5MV-25867-00	BRACKET, MASTER CYLINDER	1	1	1	1	
16	5MV-25833-00	BOLT, FITTING	2	2	2	2	
17	5XC-26372-G0	COVER, HANDLE LEVER 1	1	1	1	1	

FIG. 34 STAND & FOOTREST

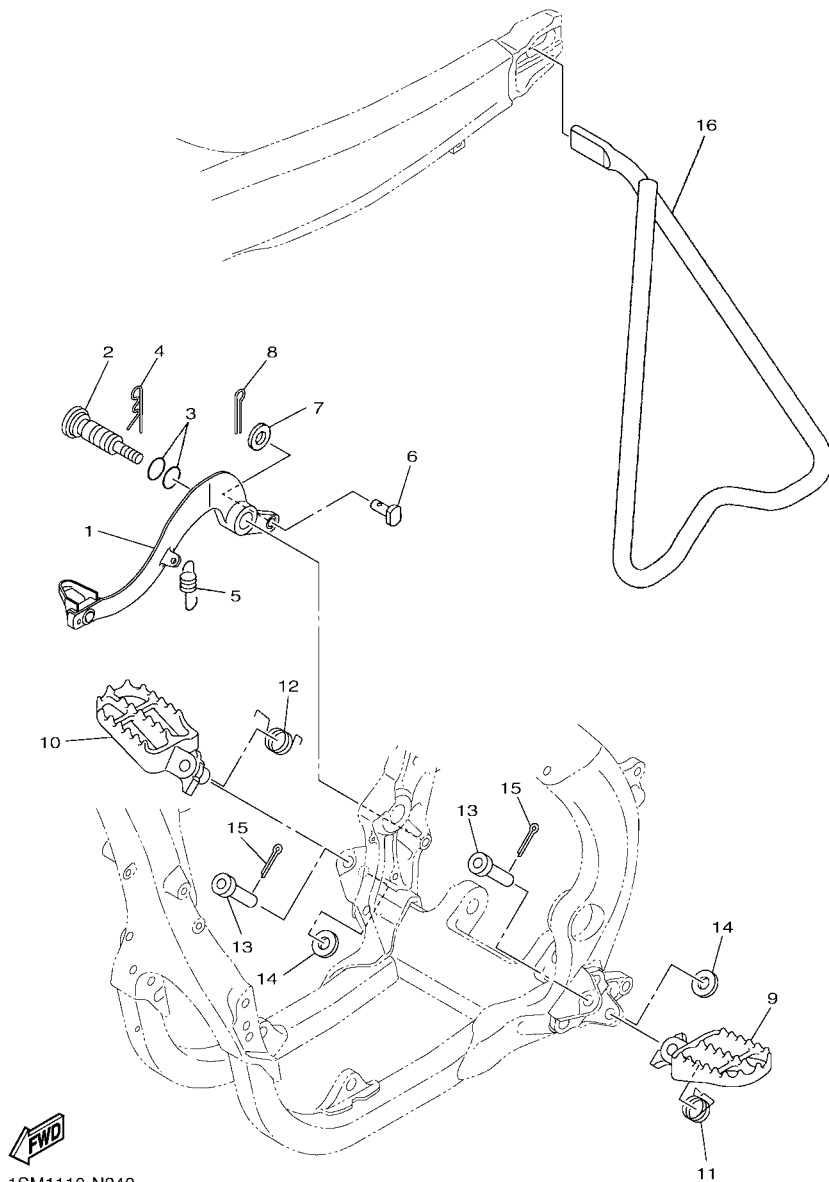

1SM1110-N340

REF. NO.	PART NO.	DESCRIPTION	1SM1	1SM2	1SM3	1SM4	REMARKS
1	17D-27200-51	PEDAL, BRAKE	1	1	1	1	
2	17D-27217-00	BOLT	1	1	1	1	
3	93210-11073	O-RING	2	2	2	2	
4	90468-16001	CLIP	1	1	1	1	
5	90506-20031	SPRING, TENSION	1	1	1	1	
6	90240-08120	PIN, CLEVIS	1	1	1	1	
7	90201-08044	WASHER, PLATE	1	1	1	1	
8	91402-20012	PIN, COTTER	1	1	1	1	
9	17D-27411-00	FOOTREST 1	1	1	1	1	
10	17D-27421-00	FOOTREST 2	1	1	1	1	
11	90508-28015	SPRING, TORSION	1	1	1	1	
12	90508-28018	SPRING, TORSION	1	1	1	1	
13	90240-10004	PIN, CLEVIS	2	2	2	2	
14	90201-10032	WASHER, PLATE	2	2	2	2	
15	91402-25015	PIN, COTTER	2	2	2	2	
16	34P-27311-00	STAND, SIDE	1	1	1	1	

FIG. 35 REAR MASTER CYLINDER

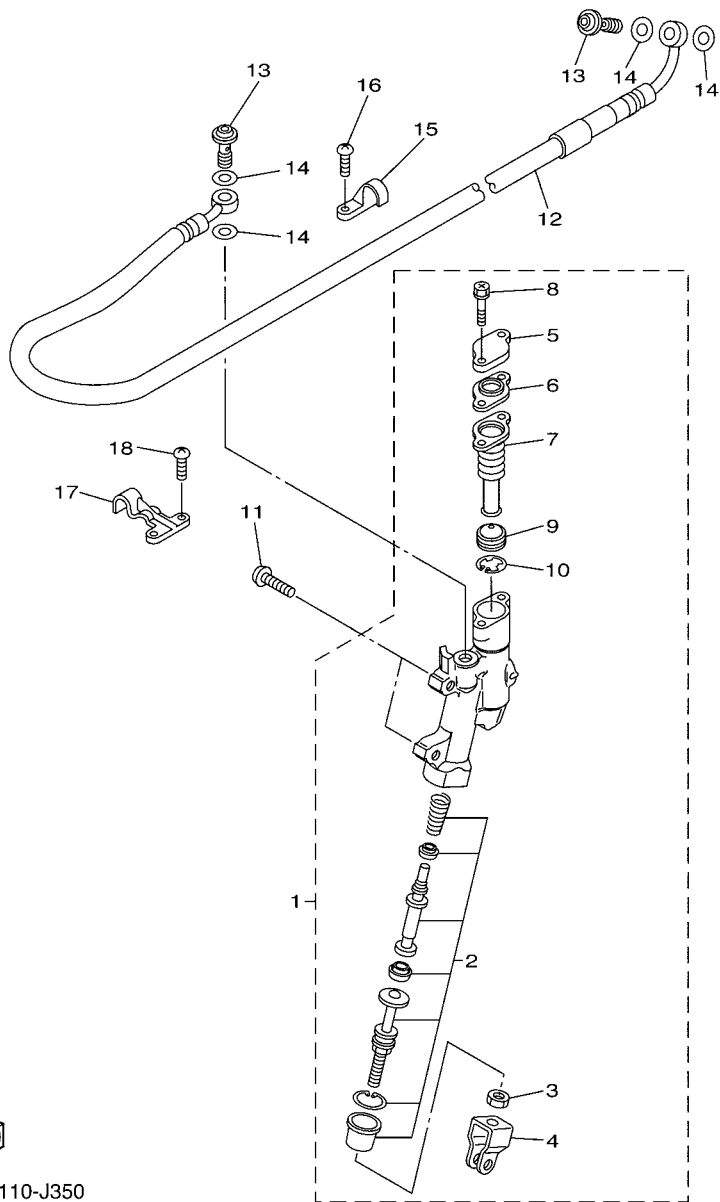

33D1110-J350

REF. NO.	PART NO.	DESCRIPTION	1SM1	1SM2	1SM3	1SM4	REMARKS
1	33D-2583V-00	RR. MASTER CYLINDER ASSY.	1	1	1	1	
2	5UN-W0042-50	.CYLINDER KIT, MASTER	1	1	1	1	
3	5UN-27218-00	.NUT	1	1	1	1	
4	5UN-27222-00	.JOINT	1	1	1	1	
5	5UN-25852-50	.CAP, RESERVOIR	1	1	1	1	
6	5UN-2585B-00	.PLATE, DIAPHRAGM	1	1	1	1	
7	5UN-25854-00	.DIAPHRAGM, RESERVOIR	1	1	1	1	
8	5UN-27217-00	.BOLT	2	2	2	2	
9	5CG-25715-00	.SEPARATOR ASSY	1	1	1	1	
10	5CG-2585G-00	.CIRCLIP	1	1	1	1	
11	90111-06116	BOLT,HEX. SOCKET BUTTON	2	2	2	2	
12	5XC-25873-L0	HOSE, BRAKE 2	1	1	1	1	
13	90401-10172	BOLT, UNION	2	2	2	2	
14	90430-10005	GASKET	4	4	4	4	
15	1C3-25886-50	HOLDER, BRAKE HOSE	1	1	1	1	
16	98502-05010	SCREW, PAN HEAD	2	2	2	2	
17	1C3-25876-50	HOLDER, BRAKE HOSE 2	1	1	1	1	
18	98502-05010	SCREW, PAN HEAD	2	2	2	2	

FIG. 38 ELECTRICAL 1

REF. NO.	PART NO.	DESCRIPTION	1SM1	1SM2	1SM3	1SM4	REMARKS
1	33D-82370-00	PLUG CAP ASSY	1	1	1	1	
2	4P9-83591-00	THERMO UNIT	1	1	1	1	
3	90430-10004	GASKET	1	1	1	1	
4	1SL-82540-00	NEUTRAL SWITCH ASSY	1	1	1	1	
5	93210-21001	O-RING	1	1	1	1	
6	90110-05062	BOLT, HEXAGON SOCKET HEAD	2	2	2	2	
7	1SM-8591A-00	ENGINE CONTROL UNIT ASSY	1				
	1SM-8591A-10	ENGINE CONTROL UNIT ASSY		1		1	
	1SM-8591A-20	ENGINE CONTROL UNIT ASSY			1		
8	90105-05005	BOLT, FLANGE	2	2	2	2	
9	90387-05048	COLLAR	2	2	2	2	
10	90480-13029	GROMMET	2	2	2	2	
11	1SM-82310-00	IGNITION COIL ASSY	1	1	1	1	
12	90480-11015	GROMMET	1	1	1	1	
13	95022-06016	BOLT, FLANGE	2	2	2	2	
14	1SL-81960-00	RECTIFIER & REGULATOR ASSY	1	1	1	1	
15	1SL-21287-00	BRACKET, REGULATOR	1	1	1	1	
16	90105-06203	BOLT, FLANGE	2	2	2	2	
17	90480-13025	GROMMET	2	2	2	2	
18	90387-066J9	COLLAR	2	2	2	2	
19	90105-06064	BOLT, FLANGE	2	2	2	2	
20	1SL-81965-00	CONDENSER, SMOOTHING	1	1	1	1	
21	1SL-21273-00	BRKT. CONDENSER	1	1	1	1	
22	92017-05012	BOLT, BUTTON HEAD	2	2	2	2	
23	1SM-82590-00	WIRE HARNESS ASSY	1	1	1	1	
24	1SL-82309-00	WIRE, SUB LEAD	1	1	1	1	
25	33D-82378-00	CONNECTOR	1	1	1	1	

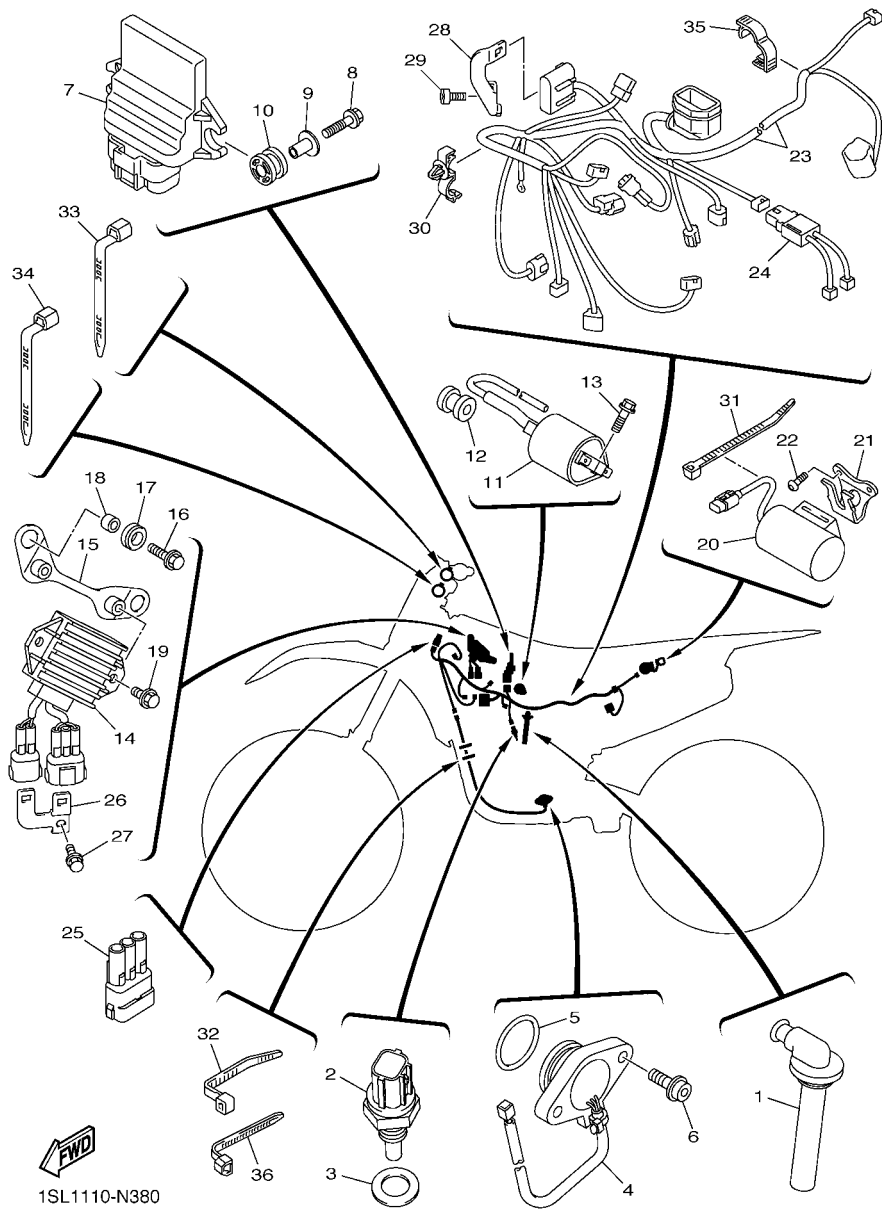

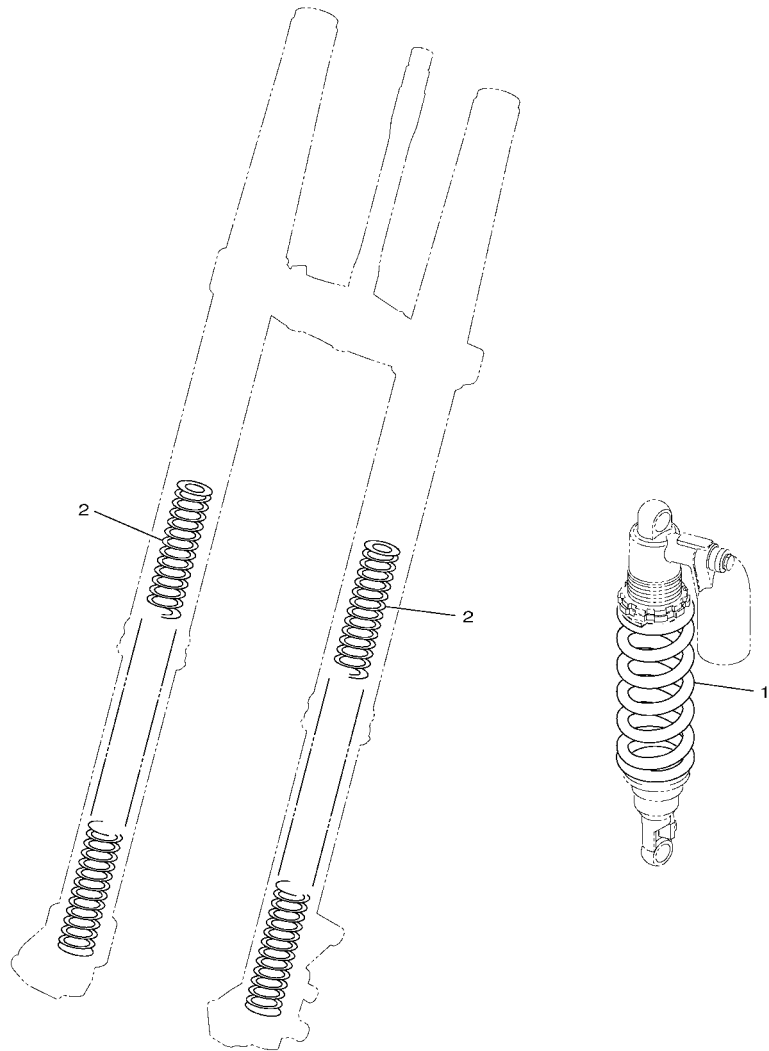

1SL1110-N390

FIG. 39 ALTERNATE FOR CHASSIS

REF. NO.	PART NO.	DESCRIPTION	1SM1	1SM2	1SM3	1SM4	REMARKS
1	1SL-22212-00	SPRING (K=58 BLUE)	1	1	1	1	AP FOR DPBSE
	1SL-22212-10	SPRING (K=58 RED)	1	1		1	AP FOR PWS1
	1SL-22212-20	SPRING (K=56 BLUE)			1	1	AP FOR DPBSE
	1SL-22212-30	SPRING (K=56 RED)	1	1		1	AP FOR PWS1
	1SL-22212-40	SPRING (K=52 BLUE)	1	1	1	1	AP FOR DPBSE
	1SL-22212-50	SPRING (K=52 RED)	1	1		1	AP FOR PWS1
	1SL-22212-60	SPRING (K=54 BLUE)	1				AP FOR DPBSE
	1SL-22212-70	SPRING (K=54 RED)	1	1		1	AP FOR PWS1
	1SL-22212-80	SPRING (K=60 BLUE)	1	1	1	1	AP FOR DPBSE
	1SL-22212-90	SPRING (K=60 RED)	1	1		1	AP FOR PWS1
2	1SL-23141-20	SPRING, FRONT FORK (K=4.5)	1	1	1	1	AP
	1SL-23141-30	SPRING, FRONT FORK (K=4.6)	1	1	1	1	AP
	1SL-23141-40	SPRING, FRONT FORK (K=4.7)	1	1	1	1	AP
	1SL-23141-50	SPRING, FRONT FORK (K=4.8)	1	1	1	1	AP
	1SL-23141-60	SPRING, FRONT FORK (K=4.9)	1	1	1	1	AP
	1SL-23141-70	SPRING, FRONT FORK (K=5.0)	1	1	1	1	AP

NUMERICAL INDEX

PART NO.	REF. NO.	PART NO.	REF. NO.	PART NO.	REF. NO.	PART NO.	REF. NO.	PART NO.	REF. NO.	PART NO.	REF. NO.
1SM-11101-09	1 - 1	3LD-12168-H1	3 - 14	1SM-13597-00	9 - 1	1SM-1477E-10	11 - 24	17D-17231-10	16 - 17	3RV-21668-B0	22 - 33
3D7-11133-10	1 - 3	3LD-12168-K1	3 - 14	1SM-13750-00	10 - 1	1SL-1477G-00	11 - 26	1SM-17241-00	16 - 16	1SL-21710-00	21 - 1
5TA-11134-10	1 - 2	3LD-12168-M1	3 - 14	1SM-13761-00	10 - 11	1SL-1477H-00	11 - 27	1SM-17251-00	16 - 20	1SL-21719-00	21 - 13
1SM-11166-00	1 - 19	3LD-12168-R1	3 - 14	33D-13907-00	26 - 15	1SM-14788-00	11 - 12	1SM-17411-00	16 - 2	1SL-2171E-00	19 - 41
1SM-11181-00	1 - 11	3LD-12168-U1	3 - 14	1SM-13938-00	10 - 2	1SM-15100-09	12 - 1	1SM-1742A-00	16 - 12	1SL-21720-00	21 - 9
1SM-11190-09	1 - 17	3LD-12168-W1	3 - 14	1SM-13971-00	26 - 19	1SM-15138-00	12 - 2	1SL-17466-00	12 - 16	1SL-2172A-00	21 - 34
1SM-11193-00	1 - 23	3LD-12168-Y1	3 - 14	3TJ-14137-40	10 - 10	1SM-15155-00	12 - 4	1SM-18101-00	18 - 10	1SL-2172F-00	21 - 35
1SM-11194-00	1 - 22	3LD-12169-11	3 - 14	1SM-14147-00	10 - 12	3Y1-15361-00	13 - 8	1SL-18110-00	18 - 14	1SL-21730-00	21 - 19
5UM-1119E-00	1 - 21	3LD-12169-31	3 - 14	1SL-14171-00	10 - 4	3Y1-15363-10	13 - 6	1SL-18122-00	18 - 3	1SM-2173E-00	21 - 8
1SM-11311-00	1 - 24	3LD-12169-50	3 - 14	1SM-141A1-00	10 - 13	17D-15378-00	13 - 20	1SL-18140-00	17 - 12	1SM-2173F-00	21 - 18
1SM-11351-00	1 - 25	3LD-12169-70	3 - 14	1DX-14216-00	10 - 9	4JT-15381-01	12 - 20	1SL-18172-00	18 - 8	1SL-21740-00	21 - 25
1SM-11400-00	2 - 1	3LD-12169-90	3 - 14	1SL-14293-00	9 - 4	18P-15383-00	12 - 18	3XJ-18173-10	18 - 2	1DX-21746-00	21 - 14
1SM-11412-00	2 - 2	3LD-12169-E0	3 - 14	33D-14325-00	10 - 5	1SM-15388-00	12 - 22	33D-18175-00	17 - 15	1SL-21748-00	21 - 23
1SM-11422-00	2 - 3	3LD-12169-G0	3 - 14	33D-14348-00	10 - 6	1SM-15411-00	13 - 1	3XJ-18178-00	18 - 4	1SL-21740-00	21 - 29
1SM-11454-00	2 - 13	3LD-12169-J0	3 - 14	1SL-14411-00	9 - 7	1SM-15415-00	13 - 21	3XJ-18182-00	18 - 5	17D-21749-00	21 - 20
1SM-11455-00	2 - 9	3LD-12169-L0	3 - 14	1SL-14412-00	9 - 26	1SL-15421-00	12 - 15	3XJ-18184-00	18 - 7	1SL-21740-00	21 - 26
1SM-11464-00	2 - 17	3LD-12169-N0	3 - 14	1SL-14412-10	9 - 26	1SM-15431-00	13 - 13	1SM-18185-00	18 - 1	5BE-21749-00	20 - 10
1SM-11531-00	2 - 12	3LD-12169-T0	3 - 14	1SL-14422-00	9 - 17	1SL-15441-00	12 - 13	1SM-18511-00	17 - 6	1SL-21740-00	21 - 11
1SM-11536-00	2 - 8	1SM-12170-00	4 - 1	1SL-14428-00	9 - 13	1SM-15451-00	13 - 9	1SM-18512-00	17 - 7	5TA-21749-00	21 - 3
1SM-11603-00	2 - 22	1SM-12180-00	4 - 2	1SL-14437-00	9 - 30	1SM-15453-00	13 - 22	1SM-18513-00	17 - 8	1SL-2175C-00	9 - 38
1SM-11631-00	2 - 21	5TA-12210-10	4 - 4	1SL-1443A-00	9 - 31	1SM-15462-00	13 - 17	1SL-18531-00	17 - 9	5FK-2175C-30	20 - 15
1SM-11633-00	2 - 23	4FM-12213-00	4 - 7	1SL-14442-00	9 - 24	1SM-15601-00	14 - 1	1SL-18535-00	17 - 10	1SM-2176M-00	21 - 4
1SM-11651-00	2 - 6	5EL-12214-00	4 - 5	1SL-14451-00	9 - 11	1SM-15620-00	14 - 18	1SM-18541-00	17 - 1	1SM-2176R-00	21 - 19
1SM-11681-00	2 - 4	5EL-12228-00	4 - 6	1SL-14452-00	9 - 27	1SM-15621-00	14 - 19	3D7-18542-00	17 - 2	1SL-217R0-10	21 - 19
1SM-116A0-00	2 - 20	1SL-12233-00	4 - 12	1SM-14453-00	9 - 8	1SM-15641-00	14 - 2	1SL-18562-00	12 - 23	1SM-217S0-00	21 - 25
1SM-12111-00	3 - 1	5BE-12241-00	1 - 18	1SL-14457-00	9 - 28	1SM-15651-00	14 - 15	1SL-21101-00	19 - 1	1SL-217S0-10	21 - 25
1SM-12113-00	3 - 6	1SM-12251-00	4 - 10	1SL-14458-00	9 - 12	5NL-15664-00	14 - 9	1SL-21163-00	19 - 37	1SL-22110-00	22 - 1
1SM-12114-00	3 - 7	1SM-12252-10	4 - 11	1SL-14459-00	9 - 9	2NX-15668-00	14 - 12	5PA-2118K-00	20 - 16	5XC-22121-91	22 - 28
1SM-12116-00	3 - 4	1SL-1240A-00	6 - 7	1SL-14462-00	9 - 18	2S2-15671-00	14 - 5	5PA-2118K-10	20 - 17	34P-22122-00	22 - 29
1SM-12117-00	3 - 8	33D-12422-00	5 - 10	33D-14486-00	10 - 3	214-15674-00	14 - 11	5PA-2118K-20	20 - 16	2S2-22128-70	22 - 11
1AA-12118-00	3 - 10	33D-12427-00	5 - 11	1DX-14562-00	10 - 8	1SM-16111-00	15 - 1	1SL-21190-00	19 - 5	33D-22141-00	22 - 15
1WG-12118-00	3 - 11	1SM-12446-00	6 - 4	1SM-14611-00	11 - 1	1SM-16150-00	15 - 5	1SL-21273-00	38 - 21	34P-22151-01	22 - 8
33M-12119-00	3 - 15	1SM-12450-00	5 - 1	5NL-14613-00	11 - 5	1SM-16154-00	15 - 6	1SL-21287-00	38 - 15	5UN-22176-00	23 - 15
4TE-12119-00	3 - 3	1SM-12453-00	5 - 5	1SM-14621-00	11 - 7	1SM-16181-00	15 - 15	1SM-21335-00	19 - 35	30X-22178-00	19 - 8
1SM-12121-00	3 - 2	1SL-12461-00	6 - 8	1SL-14628-00	11 - 2	5XC-16321-00	15 - 8	1SM-21417-00	19 - 22	3JD-22178-20	19 - 13
1SM-12126-00	3 - 5	5SL-12462-00	6 - 9	1SM-14639-00	11 - 14	5NL-16325-00	15 - 9	1SM-21418-00	19 - 23	17D-2217A-00	22 - 18
1SM-12127-00	3 - 9	33D-12465-00	6 - 10	1SL-1463B-00	11 - 9	1SM-16351-00	15 - 10	1SM-21425-00	19 - 29	33D-2217F-00	22 - 24
3FV-12153-09	3 - 13	1SL-12482-00	6 - 1	1SM-1466G-00	11 - 22	1SM-16356-00	15 - 19	1SM-21426-00	19 - 30	4V4-22184-00	19 - 9
5EB-12153-09	3 - 12	5NL-12564-00	5 - 16	1SM-1469A-00	11 - 23	1SM-16357-00	15 - 24	17D-21447-00	19 - 2	5MV-22184-00	23 - 16
3FV-12153-10	3 - 13	1SM-12576-00	6 - 14	1SM-1469A-10	11 - 23	5NL-16371-40	15 - 7	17D-21448-00	19 - 3	2S2-22199-70	22 - 10
5EB-12153-10	3 - 12	1SL-12577-00	6 - 15	1SL-1469F-00	11 - 25	1SM-16381-00	15 - 25	1SM-21471-00	19 - 32	1SM-22200-20	23 - 1
3LD-12168-00	3 - 14	1SM-12578-00	6 - 16	1SL-14714-00	11 - 28	1SM-16383-00	15 - 13	17D-21511-50	20 - 1	1SM-22200-30	23 - 1
3LD-12168-20	3 - 14	1SM-12579-00	6 - 17	1SL-14715-00	11 - 29	1SM-17121-00	16 - 9	17D-21511-60	20 - 1	1SM-22200-40	23 - 1
3LD-12168-40	3 - 14	1SM-13300-00	7 - 1	5VY-14747-00	11 - 15	1SM-17131-00	16 - 6	1SL-21610-00	20 - 8	1SM-22200-60	23 - 1
3LD-12168-60	3 - 14	1SL-13411-00	7 - 4	1SM-14750-00	11 - 19	1SM-17141-00	16 - 7	1SL-21610-10	20 - 8	1SM-22200-70	23 - 1
3LD-12168-80	3 - 14	5D3-13440-01	8 - 1	1SM-14750-10	11 - 19	1SM-17151-00	16 - 3	5XE-21635-10	20 - 9	1SM-22201-10	23 - 2
3LD-12168-A0	3 - 14	1SL-13447-00	8 - 2	5PX-14755-00	11 - 8	1SM-17211-00	16 - 21	17D-21642-00	20 - 13	1SM-22201-20	23 - 2
3LD-12168-F0	3 - 14	33D-13577-00	10 - 7	1SM-1477E-00	11 - 24	1SM-17221-00	16 - 13	3RV-21668-A0	22 - 32		

NUMERICAL INDEX

PART NO.	REF. NO.	PART NO.	REF. NO.	PART NO.	REF. NO.	PART NO.	REF. NO.	PART NO.	REF. NO.	PART NO.	REF. NO.
1SM-22201-30	23 - 2	1SL-23141-10	25 - 21	1C3-23190-L0	25 - 19	34P-25304-00	30 - 10	5XC-25873-L0	35 - 12	1SL-81450-00	36 - 2
1SL-22212-00	39 - 1		25 - 45		25 - 43	17D-2530S-00	30 - 22	1C3-25876-50	35 - 17	1SL-81528-00	36 - 7
1SL-22212-10	39 - 1	1SL-23141-20	39 - 2	33D-23340-00	25 - 49	17D-25311-00	30 - 1	1C3-25886-50	35 - 15	1SL-81960-00	38 - 14
1SL-22212-20	23 - 9	1SL-23141-30	39 - 2	17D-23389-50	24 - 2	17D-25317-00	30 - 2	5MV-2589F-00	33 - 13	1SL-81965-00	38 - 20
	39 - 1	1SL-23141-40	39 - 2	17D-23416-50	24 - 6	17D-2531B-00	28 - 6	5UN-25913-00	31 - 19	1SL-82309-00	38 - 24
1SL-22212-30	23 - 9	1SL-23141-50	39 - 2	1SL-23434-00	24 - 13		30 - 15	5UN-25914-00	31 - 17	1SM-82310-00	38 - 11
	39 - 1	1SL-23141-60	39 - 2	1SL-23435-00	24 - 9	4XM-25364-00	30 - 20	5DH-25914-50	31 - 15	33D-82370-00	38 - 1
1SL-22212-40	39 - 1	1SL-23141-70	39 - 2	18P-23441-00	24 - 11	17D-25381-00	30 - 27	3SP-25914-51	29 - 13	33D-82378-00	38 - 25
1SL-22212-50	39 - 1	17D-23142-00	25 - 13	1SL-23442-00	24 - 12	1SL-25388-00	30 - 23	5DH-25916-00	29 - 11	2C0-82380-00	10 - 15
1SL-22212-60	23 - 9		25 - 37	17D-23466-00	25 - 54	1SL-25389-00	30 - 24		31 - 14	1SL-82388-00	38 - 26
	39 - 1	5XE-23144-L0	25 - 10	17D-23467-00	25 - 55	4XM-25394-00	30 - 19	3JD-25917-00	29 - 14	1SL-82389-00	38 - 28
1SL-22212-70	23 - 9		25 - 34	33D-23472-00	19 - 6	5SF-25394-00	28 - 13		31 - 16	1SL-82540-00	38 - 4
	39 - 1	17D-23145-00	25 - 8	17D-23485-50	24 - 17	5ET-25395-00	30 - 13	5DH-25919-00	29 - 6	1SM-82590-00	38 - 23
1SL-22212-80	39 - 1		25 - 32	1SL-24110-00	26 - 1	34P-25396-00	30 - 11	17D-82911-00	31 - 6	17D-82911-00	37 - 1
1SL-22212-90	39 - 1	5XC-23146-10	25 - 7	1SL-24115-00	26 - 6	34P-25397-00	30 - 12	8CR-25924-00	31 - 13	33D-82913-00	37 - 9
1SL-22213-00	23 - 7		25 - 31	4EW-2412F-00	26 - 21	17D-25447-50	30 - 6	3SP-25926-51	29 - 12	4P9-83591-00	38 - 2
33D-22214-00	23 - 10	1AE-23147-00	25 - 18	33D-24135-00	26 - 20	17D-25448-50	30 - 6	5DH-25933-00	29 - 10	17D-83912-00	37 - 2
33D-22224-00	23 - 11		25 - 42	1S4-2414J-00	26 - 2	17D-25449-50	30 - 6	1UY-25937-51	29 - 15	5XC-83922-L0	33 - 12
4JX-22226-00	23 - 4	1C3-23147-L0	25 - 12	3FB-2415E-02	20 - 5	17D-25450-50	30 - 6		31 - 18	1SL-83976-00	37 - 11
33D-22234-00	23 - 6		25 - 36	3FB-2415E-12	20 - 6	17D-25451-50	30 - 6	17D-26111-H0	32 - 1	5LP-84126-10	37 - 4
5NY-22241-00	23 - 22	17D-23153-00	25 - 3	3FB-2415E-C1	20 - 5	17D-25452-50	30 - 6	17D-26124-00	32 - 14	1SL-85885-00	10 - 14
5XE-22242-00	23 - 19		25 - 27	4SR-2416E-00	20 - 7	5CG-25715-00	33 - 9	17D-26143-H0	32 - 15	8FP-85886-00	9 - 14
1C3-22253-50	23 - 12	5XE-23153-L0	25 - 9	1SL-24181-00	19 - 44		35 - 9	1SL-26240-00	32 - 3	1SM-8591A-00	38 - 7
1C3-22253-L1	23 - 17		25 - 33	33D-24182-00	19 - 45	17D-25718-50	31 - 20	4GY-26241-00	32 - 2	1SM-8591A-10	38 - 7
4AA-22259-40	23 - 8	2HH-23158-L0	25 - 23	33D-24183-00	19 - 46	5XC-2580T-G0	29 - 3	4GY-26242-00	32 - 4	1SM-8591A-20	38 - 7
4AA-22259-50	23 - 8		25 - 47	1SL-24188-00	26 - 3	17D-2580W-01	31 - 3	3Y1-26249-00	32 - 5	5XC-W0041-00	33 - 5
4AA-22259-70	23 - 8	17D-2315H-50	25 - 52	1SL-2419A-00	26 - 10	17D-2580W-11	31 - 3	5BE-26281-01	32 - 6	5UN-W0042-50	35 - 2
4EW-22474-00	23 - 14	17D-2315J-50	25 - 51	33D-24486-00	26 - 16	5XC-2581T-G0	29 - 1	5BE-26282-00	32 - 7	5XC-W0045-00	29 - 9
3JE-22475-00	23 - 13	1SM-2316A-00	25 - 14	33D-24491-00	26 - 17	1UY-25824-51	29 - 7	5SF-26287-11	32 - 9	1C3-W0046-50	31 - 9
5NY-22475-00	23 - 18		25 - 38	1SL-24610-00	26 - 4		31 - 7	1SM-26302-00	32 - 10	1C3-W0046-B0	31 - 9
5UN-22898-60	31 - 12	1SM-2316A-10	25 - 14	1SL-2464E-00	27 - 3	1UY-25825-51	29 - 8	1SM-26335-00	32 - 11	5KM-W0047-10	29 - 5
1C3-22969-90	22 - 9		25 - 38	18P-2464V-00	19 - 50		31 - 8	17D-26337-00	37 - 5	5UN-W0047-50	31 - 5
1SM-23102-00	25 - 1	1SM-23170-00	25 - 11	5YT-24665-00	6 - 11	5UN-25827-60	31 - 11	34P-26342-00	32 - 12	5XC-W0057-00	29 - 4
1SM-23102-10	25 - 1		25 - 35	18P-2467E-00	19 - 49	5UN-25828-60	31 - 10	34P-26372-00	37 - 8	5UN-W0057-50	31 - 4
1SM-23103-00	25 - 25	1SM-23170-10	25 - 11	1SL-2470F-00	27 - 2	2S2-2582W-70	31 - 1	5XC-26372-G0	33 - 17	5XC-W2587-00	33 - 4
1SM-23103-10	25 - 25		25 - 35	1SL-2470F-10	27 - 2	5MV-25833-00	33 - 16	17D-27200-51	34 - 1	90101-05005	37 - 7
1SL-23110-00	25 - 28	5XE-23171-L0	25 - 5	1SL-24710-00	27 - 1	33D-2583V-00	35 - 1	17D-27217-00	34 - 2	90101-06041	18 - 9
5XC-23111-00	25 - 22		25 - 29	1SL-24710-10	27 - 1	5XC-25849-G0	29 - 16	5UN-27217-00	35 - 8	90101-06044	14 - 13
	25 - 46	5DH-23183-00	23 - 5	1SL-24734-00	27 - 5	5UN-25852-50	35 - 5	5UN-27218-00	35 - 3	90101-08006	30 - 25
276-23114-00	25 - 24	509-23184-L0	23 - 3	1SL-24742-00	27 - 4	5XC-25852-G0	33 - 7	5UN-27222-00	35 - 4	90105-05005	38 - 8
	25 - 48	1C3-23188-L0	25 - 15	5NY-25104-00	28 - 7	5XC-25853-G0	33 - 11	34P-27311-00	34 - 16	90105-06027	1 - 5
1SL-23120-00	25 - 4		25 - 39	1SL-25111-00	28 - 1	5UN-25854-00	35 - 7	17D-27411-00	34 - 9	90105-06064	21 - 31
5XE-23125-L0	25 - 6	1C3-23188-N0	25 - 16	1SL-25117-00	28 - 3	5XC-25854-G0	33 - 6	17D-27421-00	34 - 10		24 - 18
	25 - 30		25 - 40	1SL-25181-00	28 - 14	5UN-2585B-00	35 - 6	17D-27491-50	31 - 22		38 - 19
33D-23136-00	25 - 2	1C3-23188-P0	25 - 17	1SL-25183-00	28 - 15	5CG-2585G-00	33 - 10	17D-2814F-00	19 - 48	90105-06081	12 - 24
	25 - 26		25 - 41	1SL-25186-00	28 - 16		35 - 10	5ET-28166-10	19 - 47	90105-06099	12 - 14
1SM-23141-00	25 - 21	1C3-23188-R0	25 - 20	56A-25195-00	28 - 9	5MV-25867-00	33 - 15	5PG-2816R-00	20 - 18	90105-06100	20 - 11
	25 - 45		25 - 44	5NY-25196-00	28 - 8	1SL-25872-00	33 - 1	1SL-81410-00	36 - 1	90105-06102	13 - 19

NUMERICAL INDEX

PART NO.	REF. NO.	PART NO.	REF. NO.	PART NO.	REF. NO.	PART NO.	REF. NO.	PART NO.	REF. NO.	PART NO.	REF. NO.
90105-06104	22 - 12	90110-06392	12 - 11	90201-08048	14 - 25	90387-06284	26 - 24	90464-18004	38 - 35	93102-08004	5 - 2
90105-06105	22 - 14	90110-08051	14 - 24		30 - 9	90387-06372	21 - 22	90464-31002	19 - 39	93102-08307	5 - 3
90105-06110	31 - 21	90111-06116	35 - 11	90201-08061	11 - 17		21 - 28		19 - 40	93102-10008	15 - 27
	31 - 23	90111-06149	26 - 23	90201-080H1	15 - 21	90387-065T2	19 - 42	90465-08062	13 - 12	93102-18278	14 - 14
	38 - 27	90116-06037	1 - 15	90201-08512	5 - 8	90387-066J9	38 - 18	90465-10098	38 - 32	93102-28012	16 - 27
90105-06111	31 - 24	90119-06096	21 - 7	90201-096J9	1 - 14	90387-066Y6	26 - 12	90465-12356	38 - 31	93102-30014	28 - 4
90105-06127	20 - 3		21 - 17	90201-10025	19 - 27	90387-06M31	21 - 15	90467-090A2	6 - 13	93102-32337	30 - 4
90105-06148	4 - 8	90119-06262	6 - 23	90201-10032	34 - 14	90387-07045	9 - 29	90467-140A4	1 - 20	93106-22002	22 - 4
90105-06156	31 - 2	90119-06268	20 - 12	90201-10035	24 - 14	90387-08032	5 - 7	90468-16001	34 - 4	93109-14010	18 - 16
90105-06170	9 - 36	90119-06M12	18 - 15	90201-10045	19 - 21	90387-08041	19 - 11	90480-01027	9 - 25	93109-21001	22 - 26
	24 - 3	90119-08133	11 - 31	90201-127E1	36 - 4	90387-08057	21 - 2	90480-01558	9 - 34	93109-25001	22 - 20
	25 - 56	90149-05031	36 - 5	90201-14020	22 - 30		21 - 10	90480-08608	30 - 21	93109-28043	22 - 5
	26 - 7	90149-06074	12 - 21	90201-15701	13 - 15	90387-08081	11 - 18	90480-10068	21 - 24	93210-11073	34 - 3
	26 - 11	90149-06083	2 - 14	90201-16018	22 - 17	90387-086N4	19 - 15		21 - 30	93210-12010	7 - 5
90105-06179	21 - 32	90149-10031	19 - 4	90201-167P7	14 - 7	90387-087L0	9 - 22	90480-10289	26 - 13	93210-14369	13 - 5
90105-06189	12 - 17	90151-06024	4 - 13	90201-177G4	14 - 16	90387-11009	21 - 21	90480-11015	38 - 12	93210-16275	6 - 5
90105-06203	9 - 37	90151-06045	14 - 22		16 - 23		21 - 27	90480-11298	9 - 32	93210-16500	6 - 3
	19 - 34	90151-06051	29 - 2	90201-20611	15 - 16	90387-14016	22 - 27	90480-12237	9 - 23	93210-16716	5 - 17
	21 - 33	90151-08007	12 - 19	90201-20685	14 - 3	90387-14020	18 - 11		9 - 33	93210-17570	14 - 23
	38 - 16	90159-06021	7 - 6	90201-21014	22 - 23	90387-16026	22 - 21	90480-13025	38 - 17	93210-19123	13 - 7
90105-08137	11 - 16	90159-06027	17 - 14	90201-22023	30 - 29	90387-17012	16 - 22	90480-13029	38 - 10	93210-196A4	16 - 25
	29 - 17	90159-06029	15 - 12	90201-286K9	24 - 8	90387-17015	12 - 8	90480-15012	6 - 21	93210-21001	38 - 5
90105-08143	19 - 24	90170-10405	2 - 19	90201-29M00	16 - 29	90387-17016	22 - 6	90480-18549	26 - 9	93210-357A3	13 - 3
	19 - 31	90170-14171	2 - 16	90208-10001	2 - 18	90387-1714S	22 - 7	90501-052G5	18 - 6	93210-45708	8 - 3
90105-08154	24 - 16	90170-16003	15 - 4	90208-14033	2 - 15	90387-175R2	2 - 11	90501-06022	17 - 3	93300-60801	5 - 4
	25 - 50	90170-16326	15 - 18	90208-16019	15 - 3	90387-19008	15 - 2	90501-064L1	17 - 11	93300-60839	19 - 14
90105-08230	11 - 32	90179-08019	30 - 26	90209-16011	22 - 22	90387-20006	16 - 8	90501-147A5	14 - 20	93306-00426	16 - 1
	19 - 7	90179-10658	19 - 20	90209-20008	16 - 4	90387-22033	16 - 26	90501-160A2	14 - 6	93306-20336	16 - 10
	21 - 6		19 - 26		16 - 18	90387-225N2	32 - 13	90501-230A6	15 - 11	93306-20351	2 - 10
	21 - 16	90179-12657	36 - 3	90209-23012	16 - 14	90401-10172	33 - 3	90506-20031	34 - 5		16 - 24
90105-08232	19 - 16	90179-18001	16 - 32	90215-16289	15 - 17		35 - 13	90508-26080	17 - 13	93306-20648	2 - 7
90105-09004	1 - 13	90179-18011	28 - 17	90215-20003	16 - 31	90430-06014	1 - 8	90508-28015	34 - 11	93306-27209	16 - 11
90105-10176	19 - 19	90179-24004	24 - 10	90240-08120	34 - 6		5 - 15	90508-28018	34 - 12	93306-80502	17 - 5
90105-10189	19 - 28	90179-28015	24 - 7	90240-10004	34 - 13	90430-06156	7 - 3	90508-29023	18 - 12	93306-90409	17 - 4
90105-10443	19 - 25	90183-061A0	9 - 16	90267-40014	9 - 35	90430-10004	38 - 3	90508-30743	14 - 10	93306-90510	30 - 3
90109-06034	37 - 3		9 - 19	90267-41004	9 - 35	90430-10005	33 - 2	91312-05008	19 - 36	93306-97203	28 - 2
90109-06232	25 - 53	90185-08008	30 - 8	90267-48121	11 - 21		35 - 14	91312-06020	9 - 2	93310-225N0	15 - 14
90109-08078	30 - 7	90185-08009	19 - 17	90269-06008	9 - 20	90430-10188	12 - 7	91312-06060	12 - 10	93310-63096	2 - 5
90110-05032	12 - 5	90185-10012	23 - 23	90280-03006	2 - 25	90445-09008	26 - 5	91317-06075	12 - 12	93315-32166	22 - 19
	36 - 8	90185-14010	22 - 31	90340-12007	1 - 6	90450-22001	6 - 20	91380-06012	38 - 29		22 - 25
90110-05033	7 - 2	90185-16002	22 - 16	90340-14011	13 - 4	90450-25001	6 - 19	91402-20012	34 - 8	93317-11096	15 - 26
90110-05058	26 - 18	90185-22011	30 - 28	90340-36002	13 - 2	90450-28001	6 - 18	91402-25015	34 - 15	93317-22262	22 - 2
90110-05062	38 - 6	90201-05017	11 - 3	90387-05048	38 - 9	90450-58007	9 - 6	91808-16023	1 - 4	93332-00068	24 - 5
90110-05064	11 - 20		11 - 10	90387-06065	6 - 22	90450-60004	9 - 3	91A20-05065	6 - 12	93332-00081	24 - 1
90110-05066	9 - 5	90201-06108	20 - 4	90387-06091	26 - 8	90464-13073	38 - 34	92012-06010	19 - 38	93340-21008	15 - 20
90110-06161	36 - 6	90201-08043	19 - 18	90387-06105	24 - 4	90464-13077	38 - 33	92017-05012	38 - 22	93342-22217	22 - 3
90110-06380	1 - 27	90201-08044	34 - 7	90387-06106	19 - 33	90464-15195	38 - 36	92902-10200	23 - 21	93410-20038	14 - 4
90110-06391	12 - 9	90201-08045	19 - 10	90387-06259	20 - 2	90464-17003	38 - 30	93101-14164	13 - 14	93410-22039	16 - 5

NUMERICAL INDEX

PART NO.	REF. NO.	PART NO.	REF. NO.	PART NO.	REF. NO.	PART NO.	REF. NO.	PART NO.	REF. NO.	PART NO.	REF. NO.
93410-22039	16 - 19	95602-10200	23 - 20								
93410-26067	16 - 15		24 - 15								
93440-07182	5 - 9	95612-08620	1 - 9								
	15 - 22	95701-06500	33 - 14								
93440-41178	4 - 3	95702-06500	1 - 16								
93450-17129	2 - 24		22 - 13								
93450-40N50	16 - 28	95702-08500	11 - 6								
93507-32009	14 - 21	97702-40012	21 - 5								
93511-32027	15 - 23	97702-50520	9 - 15								
93603-12007	5 - 6	97702-60016	20 - 14								
93604-10011	5 - 12	98502-05010	35 - 16								
93608-33002	18 - 13		35 - 18								
93612-16254	1 - 12	98502-05014	9 - 10								
	1 - 26		9 - 21								
9383B-13218	16 - 30	98507-05020	32 - 8								
94108-21027	28 - 10	98706-04012	33 - 8								
94110-19019	30 - 16	98707-06025	26 - 22								
94209-21229	28 - 11	98980-06008	11 - 4								
94210-19222	30 - 17		11 - 11								
94316-19156	30 - 18	99009-16400	14 - 8								
94330-21084	28 - 12	99009-17400	14 - 17								
94416-21034	28 - 5	99009-18500	15 - 28								
94416-21045	28 - 5	99009-22500	13 - 16								
94418-19026	30 - 14	99009-42700	30 - 5								
94418-19036	30 - 14	99530-08016	13 - 10								
94591-57114	4 - 9	99530-12016	13 - 18								
94681-68001	30 - 31	99530-14016	12 - 3								
94682-28001	30 - 31	9Y581-92113	30 - 30								
94701-00434	1 - 10	9Y582-28113	30 - 30								
94703-00434	1 - 10										
95022-06010	1 - 7										
	5 - 14										
95022-06012	6 - 2										
95022-06016	8 - 4										
	19 - 43										
	38 - 13										
95022-06020	6 - 6										
	26 - 14										
	37 - 10										
95022-06025	5 - 13										
	13 - 23										
95022-06030	13 - 11										
95022-06060	13 - 24										
95022-08040	19 - 12										
95022-10016	12 - 6										
95024-08040	11 - 13										
	11 - 30										
95302-05600	37 - 6										