



# PARTS CATALOGUE

**YZ250FF** (1SM5) CANADA

**YZ250F** (1SM6) EUROPE

**YZ250F** (1SM7) JAPAN

**YZ250FF** (1SM8) OCEANIA, SOUTH AFRICA

1P1SM-100E1

( )

 **YAMAHA**  
**GENUINE**  
Parts & Accessories

NEWS No.	DATE	COMMENT
PE0-MC-140062	Oct.,24,2014	COR:FIG.11 EXHAUST ILLUSTRATION CORRECTION

2014/10/28

YZ250FF/YZ250F  
PARTS CATALOGUE  
©2014 by Yamaha Motor Co., Ltd.  
1st edition, May 2014  
All rights reserved.  
Any reprinting or unauthorized use  
without the written permission of  
Yamaha Motor Co., Ltd.  
is expressly prohibited.  
Printed in Japan.

# FOREWORD

This Parts Catalogue is related to the parts for the model(s) on the cover page. When you are ordering replacement parts, please refer to this Parts Catalogue and quote both part numbers and part names correctly.

1. Modifications or additions which have been made after the issue of the Parts Catalogue will be announced in the Parts News.

It is advisable that you make the necessary corrections to the Parts Catalogue according to the Parts News.

2. Abbreviations

The following abbreviations are used in this Parts Catalogue.

“UR” Use specified parts number.

“UN” Use as many as needed.

“AP” Alternate Parts

“LM” Locally Made (Parts need to be ordered locally)

“F#” Frame No. (Applicable machine No.)

“O/S” Over Size

3. The number of components for assembly

- Parts, which are to be supplied in an assembly, are listed with a dot (.) in front of the part name as shown below.
- The numeral appearing to the right of each component part indicates the quantity of parts for each assembly unit.

PART NO.	DESCRIPTION	Q'TY	REMARKS
2F5-83310-60	FRONT FLASHER LIGHT ASSY	2	
115-83311-60	.BULB (6V-18W)	1	

4. Applicable colours of graphics are represented in the “REMARKS” as shown below.

PART NO.	DESCRIPTION	Q'TY	REMARKS
2N4-24110-00-X5	FUEL TANK COMP.	2	MXR
3J1-24240-10	.GRAPHIC, FUEL TANK	1	FOR MXR

5. Note that the illustrations for reference in finding parts numbers are not to be used for assembling. When assembling, please use the applicable service manual.

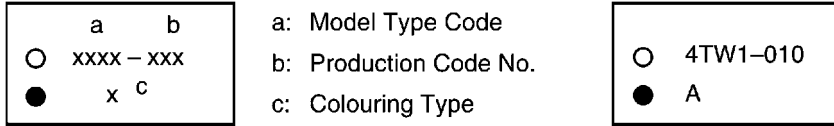
6. The asterisk (\*) before a reference number indicates modified items after the first edition.



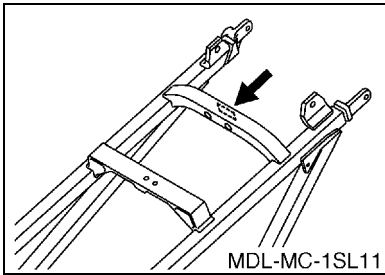
# MODEL LABEL

(1) A label called "Model Label" is affixed in the location as indicated in (3) below. When using this parts catalogue, please be sure to cross-reference the "model code – production code No." in the catalogue with the "model code – production code No." indicated on the Model Label affixed onto the product concerned.

(2) "Model Label" Indication



(3) Model Label Affixing Location



(4) Colouring Information

Model Code	Colouring Type Code	Colour Code	Colour Name	Abbreviation
1SM5	A	0583	DEEP PURPLISH BLUE SOLID E	DPBSE
	B	0206	PURPLISH WHITE SOLID 1	PWS1
1SM6	A	0583	DEEP PURPLISH BLUE SOLID E	DPBSE
1SM7	A	0583	DEEP PURPLISH BLUE SOLID E	DPBSE
1SM8	A	0583	DEEP PURPLISH BLUE SOLID E	DPBSE
	B	0206	PURPLISH WHITE SOLID 1	PWS1

(5) Model Code – Production Code Number of Model Listed in This Parts Catalogue

Model Code	Production Code No.	Country (destination)	Model Code	Production Code No.	Country (destination)
1SM5	020	CANADA	1SM8	010	AUSTRALIA
1SM6	010	AUSTRIA			NEW ZEALAND
		BELGIUM			SOUTH AFRICA
		CYPRUS			
		CZECHO			
		DENMARK			
		FINLAND			
		FRANCE			
		GERMANY			
		GREECE			
		HUNGARY			
		IRELAND			
		ITALY			
		NETHERLANDS			
		NORWAY			
		POLAND			
		PORTUGAL			
		SLOVAK			
SLOVENIA					
SPAIN					
SWEDEN					
SWITZERLAND					
TURKEY					
UNITED KINGDOM					
1SM7	010	JAPAN			

# CONTENTS

## ENGINE

CYLINDER .....	1
CRANKSHAFT & PISTON .....	3
VALVE .....	4
CAMSHAFT & CHAIN .....	6
WATER PUMP .....	7
RADIATOR & HOSE .....	8
OIL PUMP .....	9
OIL CLEANER .....	10
INTAKE .....	11
INTAKE 2 .....	13
EXHAUST .....	14
CRANKCASE .....	16
CRANKCASE COVER 1 .....	17
STARTER .....	18
CLUTCH .....	19
TRANSMISSION .....	21
SHIFT CAM & FORK .....	23
SHIFT SHAFT .....	24

## CHASSIS

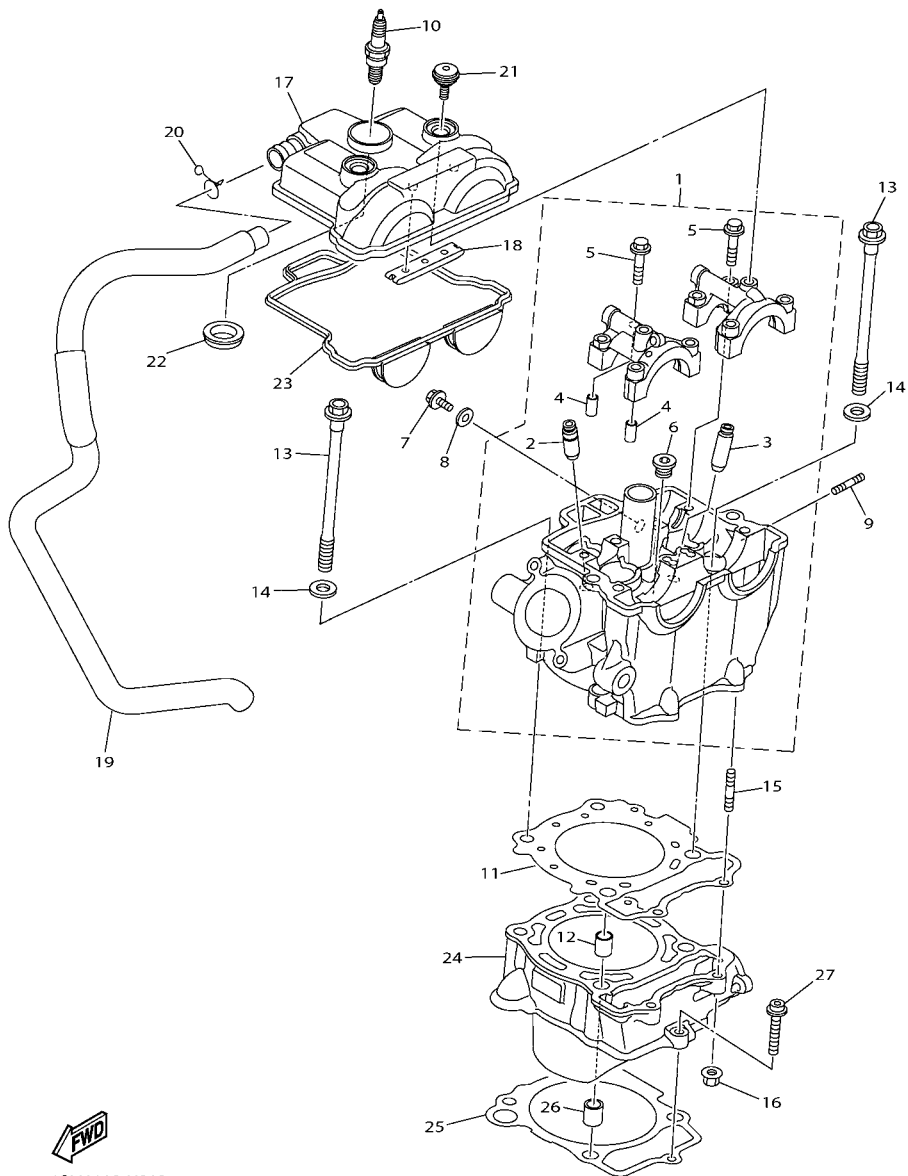
FRAME .....	25
FENDER .....	27
SIDE COVER .....	28
REAR ARM .....	30
REAR SUSPENSION .....	32
STEERING .....	34
FRONT FORK .....	35
FUEL TANK .....	38
SEAT .....	39
FRONT WHEEL .....	40
FRONT BRAKE CALIPER .....	41
REAR WHEEL .....	42
REAR BRAKE CALIPER .....	44
STEERING HANDLE & CABLE .....	45
FRONT MASTER CYLINDER .....	46
STAND & FOOTREST .....	47
REAR MASTER CYLINDER .....	48
GENERATOR .....	49
HANDLE SWITCH & LEVER .....	50
ELECTRICAL 1 .....	51
ALTERNATE FOR CHASSIS .....	53

## INDEX

NUMERICAL INDEX .....	54
-----------------------	----

FIG. 1 CYLINDER

REF. NO.	PART NO.	DESCRIPTION	1SM5	1SM6	1SM7	1SM8	REMARKS
1	1SM-11101-09	CYLINDER HEAD ASSY	1	1	1	1	
2	5TA-11134-10	.GUIDE, VALVE 2	2	2	2	2	
3	3D7-11133-10	.GUIDE, VALVE 1	2	2	2	2	
4	91808-16023	.PIN, DOWEL	4	4	4	4	
5	90105-06027	.BOLT, FLANGE	8	8	8	8	
6	90340-12007	.PLUG, STRAIGHT SCREW	1	1	1	1	
7	95022-06010	BOLT, FLANGE	1	1	1	1	
8	90430-06014	GASKET	1	1	1	1	
9	95612-08620	BOLT, STUD	2	2	2	2	
10	94701-00434	PLUG, SPARK (NGK LMAR8G)	1	1		1	
	94703-00434	PLUG, SPARK (NGK LMAR8G)			1		
11	1SM-11181-00	GASKET, CYLINDER HEAD 1	1	1	1	1	
12	93612-16254	PIN, DOWEL	2	2	2	2	
13	90105-09004	BOLT, FLANGE	4	4	4	4	
14	90201-096J9	WASHER, PLATE	4	4	4	4	
15	90116-06037	BOLT, STUD	2	2	2	2	
16	95702-06500	NUT, FLANGE	2	2	2	2	
17	1SM-11190-09	COVER, CYLINDER HEAD 1	1	1	1	1	
18	5BE-12241-00	GUIDE, STOPPER 2	1	1	1	1	
19	1SM-11166-00	PIPE, BREATHER 1	1	1	1	1	
20	90467-140A4	CLIP	1	1	1	1	
21	5UM-1119E-00	BOLT, COVER HEAD	2	2	2	2	
22	1SM-11194-00	GASKET, HEAD COVER 2	1	1	1	1	
23	1SM-11193-00	GASKET, HEAD COVER 1	1	1	1	1	
24	1SM-11311-00	CYLINDER 1	1	1	1	1	
25	1SM-11351-00	GASKET, CYLINDER	1	1	1	1	
26	93612-16254	PIN, DOWEL	2	2	2	2	



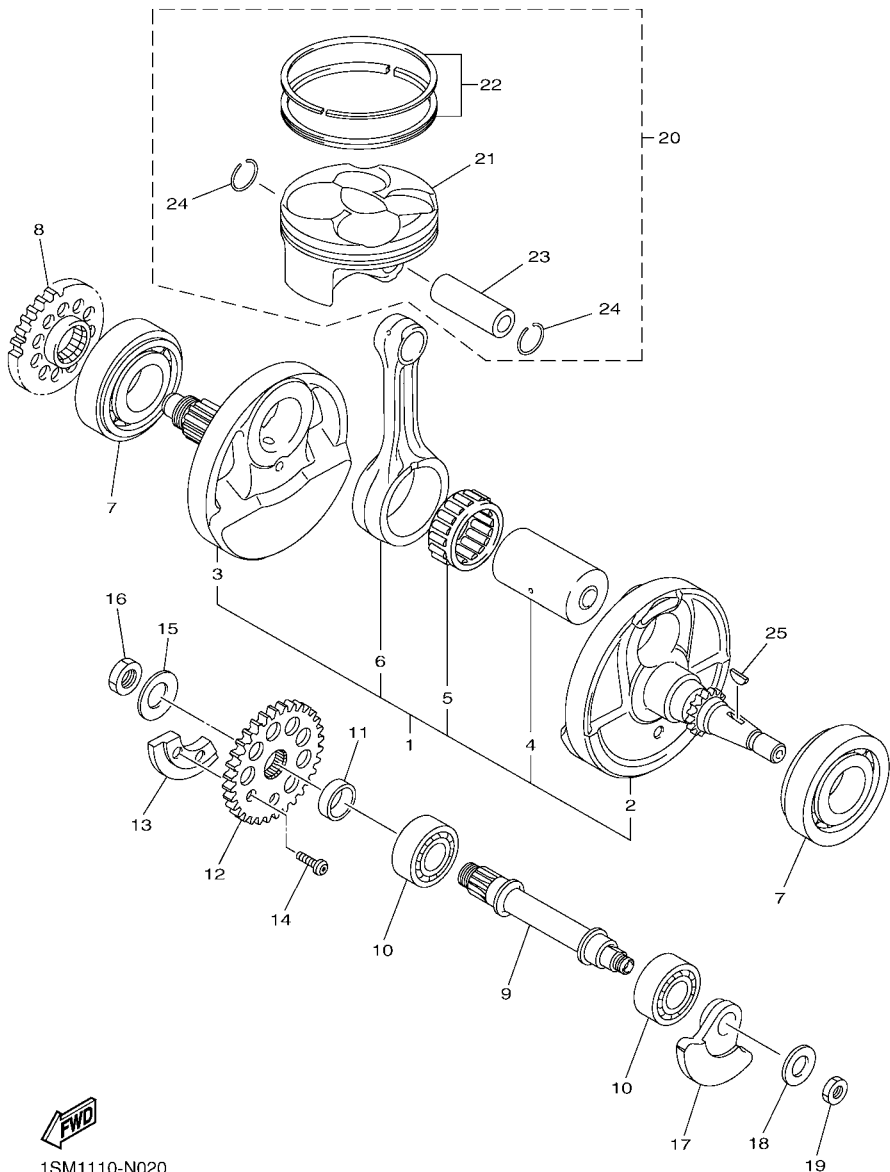
1SM1110-N010



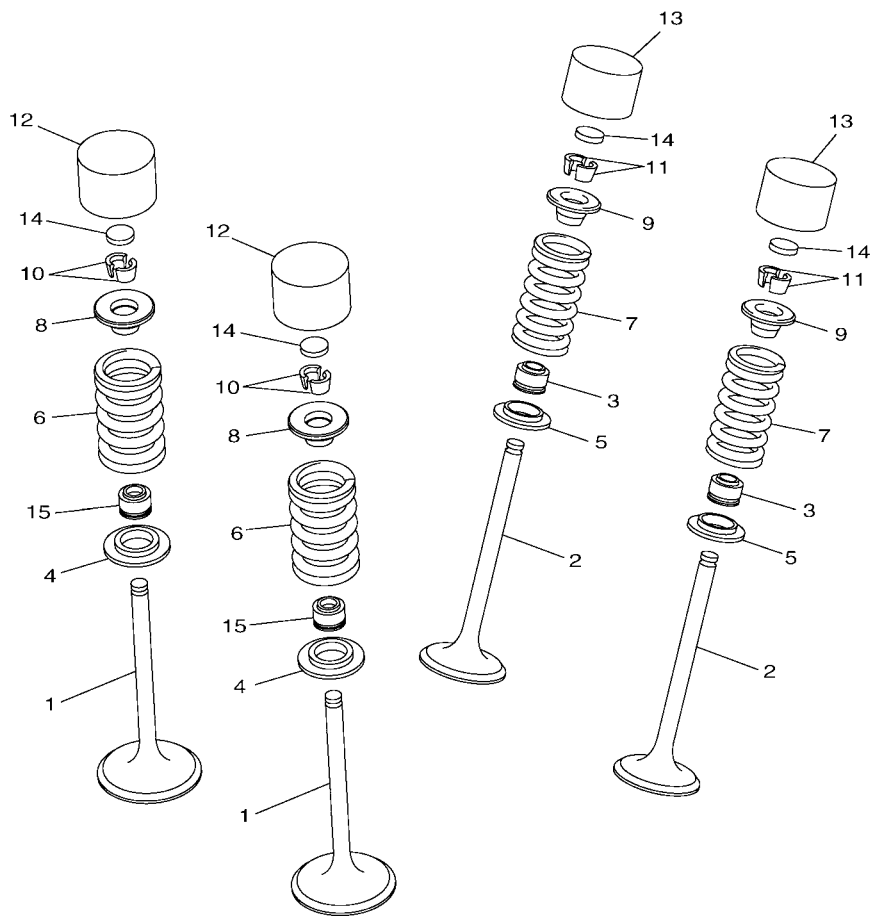


**FIG. 2 CRANKSHAFT & PISTON**

REF. NO.	PART NO.	DESCRIPTION	ISM5	ISM6	ISM7	ISM8	REMARKS
1	1SM-11400-01	CRANKSHAFT ASSY	1	1	1	1	
2	1SM-11412-00	.CRANK 1	1	1	1	1	
3	1SM-11422-00	.CRANK 2	1	1	1	1	
4	1SM-11681-00	.PIN, CRANK 1	1	1	1	1	
5	93310-63096	.BEARING	1	1	1	1	
6	1SM-11651-01	.ROD, CONNECTING	1	1	1	1	
7	93306-20648	BEARING	2	2	2	2	
8	1SM-11536-00	GEAR, DRIVE (30T)	1	1	1	1	
9	1SM-11455-00	SHAFT 1	1	1	1	1	
10	93306-20351	BEARING	2	2	2	2	
11	90387-175R2	COLLAR	1	1	1	1	
12	1SM-11531-00	GEAR, BALANCE WEIGHT	1	1	1	1	
13	1SM-11454-00	WEIGHT 1	1	1	1	1	
14	90149-06083	SCREW	2	2	2	2	
15	90208-14033	WASHER, CONICAL SPRING	1	1	1	1	
16	90170-14171	NUT	1	1	1	1	
17	1SM-11464-00	WEIGHT 2	1	1	1	1	
18	90208-10001	WASHER, CONICAL SPRING	1	1	1	1	
19	90170-10405	NUT	1	1	1	1	
20	1SM-116A0-01	PISTON ASSY	1	1	1	1	
21	1SM-11631-01	.PISTON (STD)	1	1	1	1	
22	1SM-11603-00	.PISTON RING SET (STD)	1	1	1	1	
23	1SM-11633-00	.PIN, PISTON	1	1	1	1	
24	93450-17129	.CIRCLIP	2	2	2	2	
25	90280-03006	KEY, WOODRUFF	1	1	1	1	



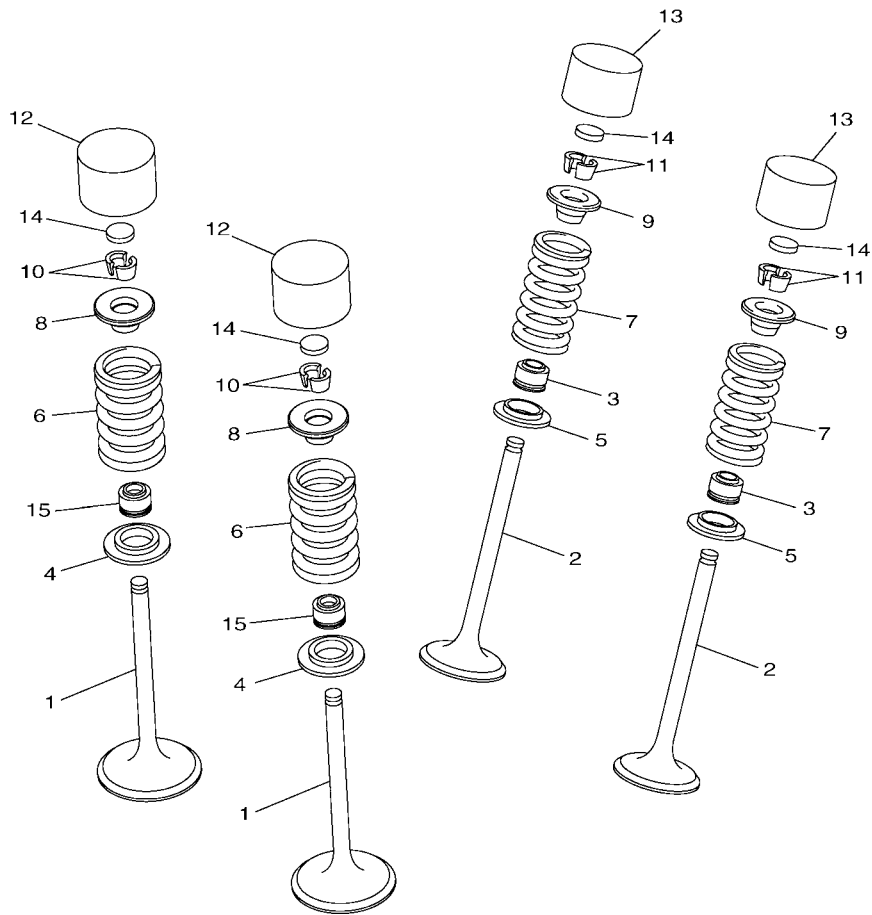
1SM1110-N020



1SM1110-N030

FIG. 3 VALVE

REF. NO.	PART NO.	DESCRIPTION	1SM5	1SM6	1SM7	1SM8	REMARKS
1	1SM-12111-00	VALVE, INTAKE	2	2	2	2	
2	1SM-12121-10	VALVE, EXHAUST	2	2	2	2	
3	4TE-12119-00	SEAL, VALVE STEM	2	2	2	2	
4	1SM-12116-00	SEAT, VALVE SPRING	2	2	2	2	
5	1SM-12126-00	SEAT, VALVE SPRING 2	2	2	2	2	
6	1SM-12113-00	SPRING, VALVE INNER	2	2	2	2	
7	1SM-12114-00	SPRING, VALVE OUTER	2	2	2	2	
8	1SM-12117-00	RETAINER, VALVE SPRING	2	2	2	2	
9	1SM-12127-00	RETAINER, VALVE SPRING	2	2	2	2	
10	1AA-12118-00	LOCK, VALVE SPRING RETAINER	4	4	4	4	
11	1WG-12118-00	LOCK, VALVE SPRING RETAINER	4	4	4	4	
12	5EB-12153-10	LIFTER, VALVE	2	2	2	2	YELLOW
	5EB-12153-09	LIFTER, VALVE (O/S)	2	2	2	2	GREEN
13	3FV-12153-10	LIFTER, VALVE	2	2	2	2	YELLOW
	3FV-12153-09	LIFTER, VALVE (O/S)	2	2	2	2	GREEN
14	3LD-12168-00	PAD, ADJUSTING (1.20)	4	4	4	4	UR
	3LD-12168-20	PAD, ADJUSTING (1.25)	4	4	4	4	UR
	3LD-12168-40	PAD, ADJUSTING (1.30)	4	4	4	4	UR
	3LD-12168-60	PAD, ADJUSTING (1.35)	4	4	4	4	UR
	3LD-12168-80	PAD, ADJUSTING (1.40)	4	4	4	4	UR
	3LD-12168-A0	PAD, ADJUSTING (1.45)	4	4	4	4	UR
	3LD-12168-F0	PAD, ADJUSTING (1.50)	4	4	4	4	UR
	3LD-12168-H1	PAD, ADJUSTING (1.55)	4	4	4	4	UR
	3LD-12168-K1	PAD, ADJUSTING (1.60)	4	4	4	4	UR
	3LD-12168-M1	PAD, ADJUSTING (1.65)	4	4	4	4	UR
	3LD-12168-R1	PAD, ADJUSTING (1.70)	4	4	4	4	UR
	3LD-12168-U1	PAD, ADJUSTING (1.75)	4	4	4	4	UR



1SM1110-N030

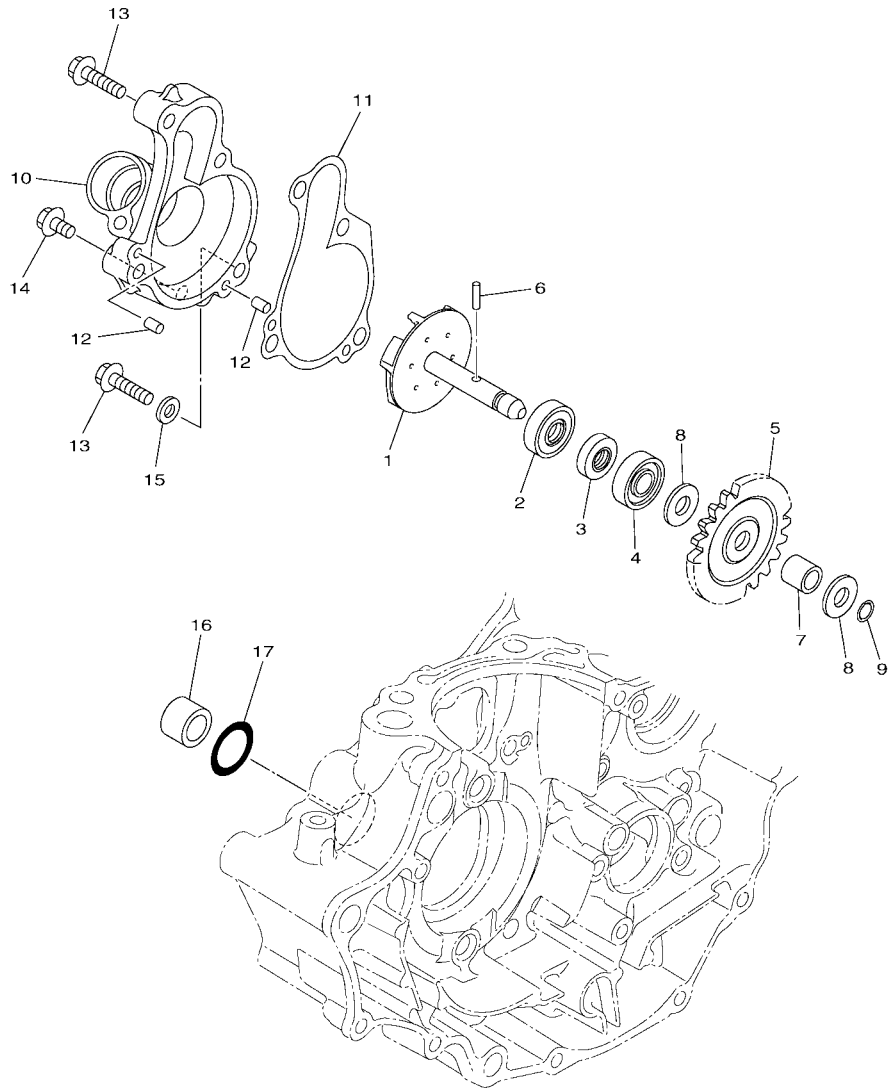
FIG. 3 VALVE

REF. NO.	PART NO.	DESCRIPTION	1SM5	1SM6	1SM7	1SM8	REMARKS
14	3LD-12168-W1	PAD, ADJUSTING (1.80)	4	4	4	4	UR
	3LD-12168-Y1	PAD, ADJUSTING (1.85)	4	4	4	4	UR
	3LD-12169-11	PAD, ADJUSTING (1.90)	4	4	4	4	UR
	3LD-12169-31	PAD, ADJUSTING (1.95)	4	4	4	4	UR
	3LD-12169-50	PAD, ADJUSTING (2.00)	4	4	4	4	UR
	3LD-12169-70	PAD, ADJUSTING (2.05)	4	4	4	4	UR
	3LD-12169-90	PAD, ADJUSTING (2.10)	4	4	4	4	UR
	3LD-12169-E0	PAD, ADJUSTING (2.15)	4	4	4	4	UR
	3LD-12169-G0	PAD, ADJUSTING (2.20)	4	4	4	4	UR
	3LD-12169-J0	PAD, ADJUSTING (2.25)	4	4	4	4	UR
	3LD-12169-L0	PAD, ADJUSTING (2.30)	4	4	4	4	UR
	3LD-12169-N0	PAD, ADJUSTING (2.35)	4	4	4	4	UR
	3LD-12169-T0	PAD, ADJUSTING (2.40)	4	4	4	4	UR
15	33M-12119-00	SEAL, VALVE STEM	2	2	2	2	



**FIG. 5 WATER PUMP**

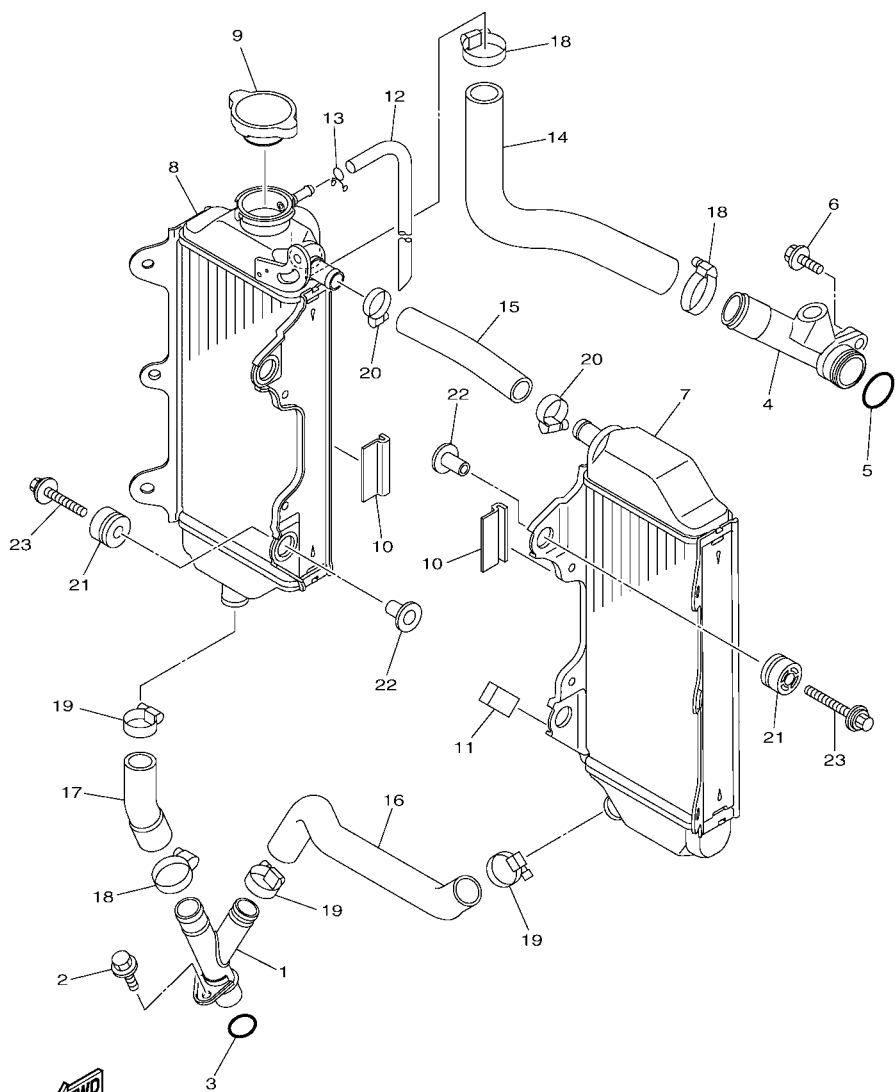
REF. NO.	PART NO.	DESCRIPTION	ISM5	ISM6	ISM7	ISM8	REMARKS
1	1SM-12450-00	IMPELLER SHAFT ASSY	1	1	1	1	
2	93102-08004	OIL SEAL	1	1	1	1	
3	93102-08307	OIL SEAL	1	1	1	1	
4	93300-60801	BEARING	1	1	1	1	KOYO
5	1SM-12453-00	GEAR	1	1	1	1	
6	93603-12007	PIN, DOWEL	1	1	1	1	
7	90387-08032	COLLAR	1	1	1	1	
8	90201-08512	WASHER, PLATE	2	2	2	2	
9	93440-07182	CIRCLIP	1	1	1	1	
10	33D-12422-00	COVER, HOUSING	1	1	1	1	
11	33D-12427-00	GASKET, HOUSING COVER 1	1	1	1	1	
12	93604-10011	PIN, DOWEL	2	2	2	2	
13	95022-06025	BOLT, FLANGE	4	4	4	4	
14	95022-06010	BOLT, FLANGE	1	1	1	1	
15	90430-06014	GASKET	1	1	1	1	
16	5NL-12564-00	PIPE, WATER	1	1	1	1	
17	93210-16716	O-RING	1	1	1	1	



1SM1110-N050

**FIG. 6 RADIATOR & HOSE**

REF. NO.	PART NO.	DESCRIPTION	1SM5	1SM6	1SM7	1SM8	REMARKS
1	1SL-12482-00	PIPE 2	1	1	1	1	
2	95022-06012	BOLT, FLANGE	1	1	1	1	
3	93210-16500	O-RING	1	1	1	1	
4	1SM-12446-00	JOINT	1	1	1	1	
5	93210-16275	O-RING	1	1	1	1	
6	95022-06020	BOLT, FLANGE	1	1	1	1	
7	1SL-1240A-00	RADIATOR ASSY	1	1	1	1	
8	1SL-12461-00	RADIATOR COMP	1	1	1	1	
9	5SL-12462-00	CAP, RADIATOR	1	1	1	1	
10	33D-12465-00	DAMPER, RADIATOR	2	2	2	2	
11	5YT-24665-00	DAMPER	1	1	1	1	
12	91A20-05065	TUBE, FLEXIBLE VINYL	1	1	1	1	
13	90467-090A2	CLIP	1	1	1	1	
14	1SM-12576-00	HOSE 1	1	1	1	1	
15	1SL-12577-00	HOSE 2	1	1	1	1	
16	1SM-12578-00	HOSE 3	1	1	1	1	
17	1SM-12579-00	HOSE 4	1	1	1	1	
18	90450-28001	HOSE CLAMP ASSY	3	3	3	3	
19	90450-25001	HOSE CLAMP ASSY	3	3	3	3	
20	90450-22001	HOSE CLAMP ASSY	2	2	2	2	
21	90480-15012	GROMMET	4	4	4	4	
22	90387-06065	COLLAR	4	4	4	4	
23	90119-06262	BOLT, WITH WASHER	4	4	4	4	



1SM1110-N060







FIG. 9 INTAKE

REF. NO.	PART NO.	DESCRIPTION	ISM5	ISM6	ISM7	ISM8	REMARKS
1	1SM-13597-00	JOINT, CARBURETOR 3	1	1	1	1	
2	91312-06020	BOLT	2	2	2	2	
3	90450-60004	HOSE CLAMP ASSY	1	1	1	1	
4	1SL-14293-00	COVER 1	1	1	1	1	
5	90110-05066	BOLT, HEXAGON SOCKET HEAD	1	1	1	1	
6	90450-58007	HOSE CLAMP ASSY	1	1	1	1	
7	1SL-14411-00	CASE, AIR CLEANER 1	1	1	1	1	
8	1SM-14453-00	JOINT, AIR CLEANER 1	1	1	1	1	
9	1SL-14459-00	HOLDER, GUIDE	1	1	1	1	
10	98502-05014	SCREW, PAN HEAD	8	8	8	8	
11	1SL-14451-00	ELEMENT, AIR CLEANER	1	1	1	1	
12	1SL-14458-00	GUIDE	1	1	1	1	
13	1SL-14428-00	BOLT	1	1	1	1	
14	8FP-85886-00	SENSOR, AIR TEMPERATURE	1	1	1	1	
15	97702-50520	SCREW, TAPPING	1	1	1	1	
16	4XV-2177L-01	PLATE, SPRING	1	1	1	1	
17	1SL-14422-00	CAP, CLEANER CASE 2	1	1	1	1	
18	1SL-14462-00	SEAL	1	1	1	1	
19	4XV-2177L-01	PLATE, SPRING	2	2	2	2	
20	90269-06008	RIVET	2	2	2	2	
21	98502-05014	SCREW, PAN HEAD	1	1	1	1	
22	90387-087L0	COLLAR	1	1	1	1	
23	90480-12237	GROMMET	1	1	1	1	
24	1SL-14442-00	SPACER	2	2	2	2	
25	90480-01027	GROMMET	2	2	2	2	
26	1SL-14412-00	CAP, CLEANER CASE 1	1	1	1	1	UR FOR DPBSE
	1SL-14412-10	CAP, CLEANER CASE 1	1			1	UR FOR PWS1

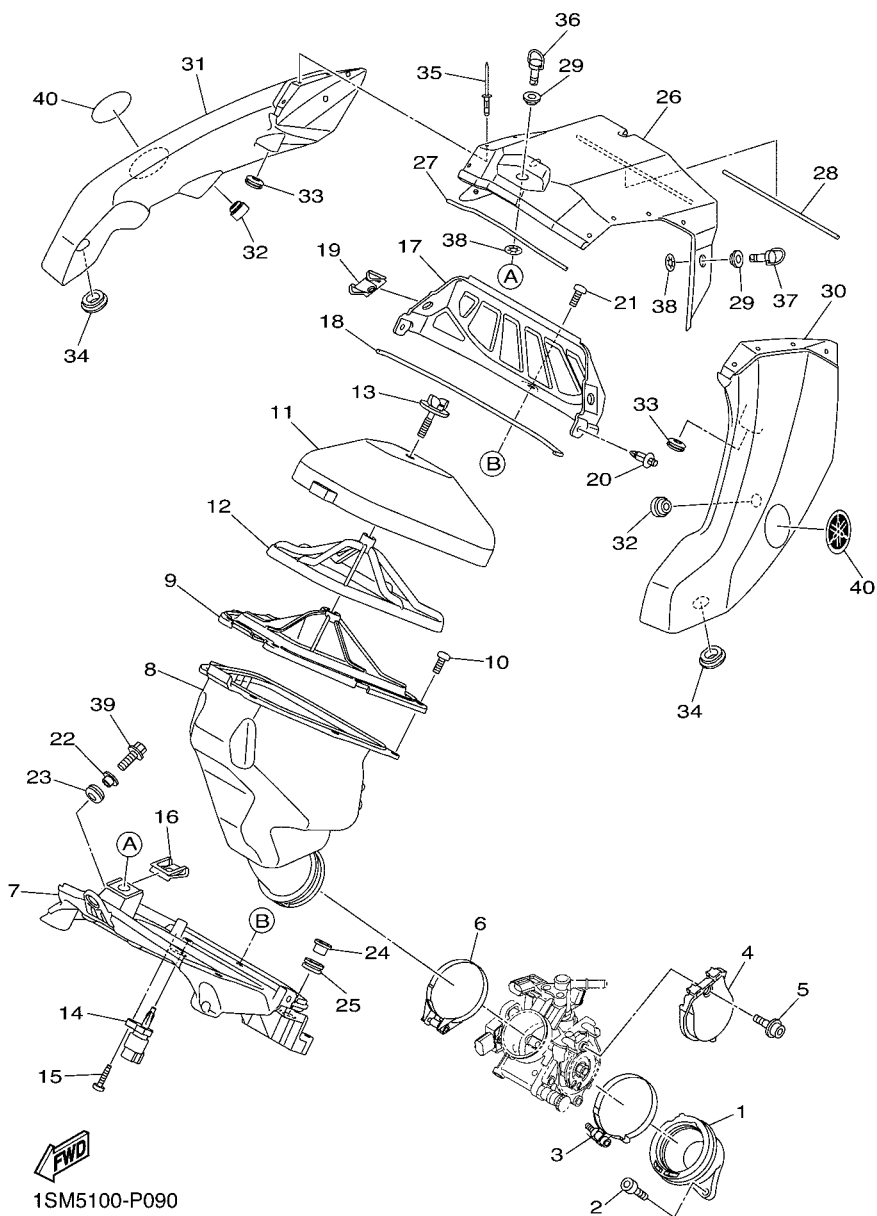
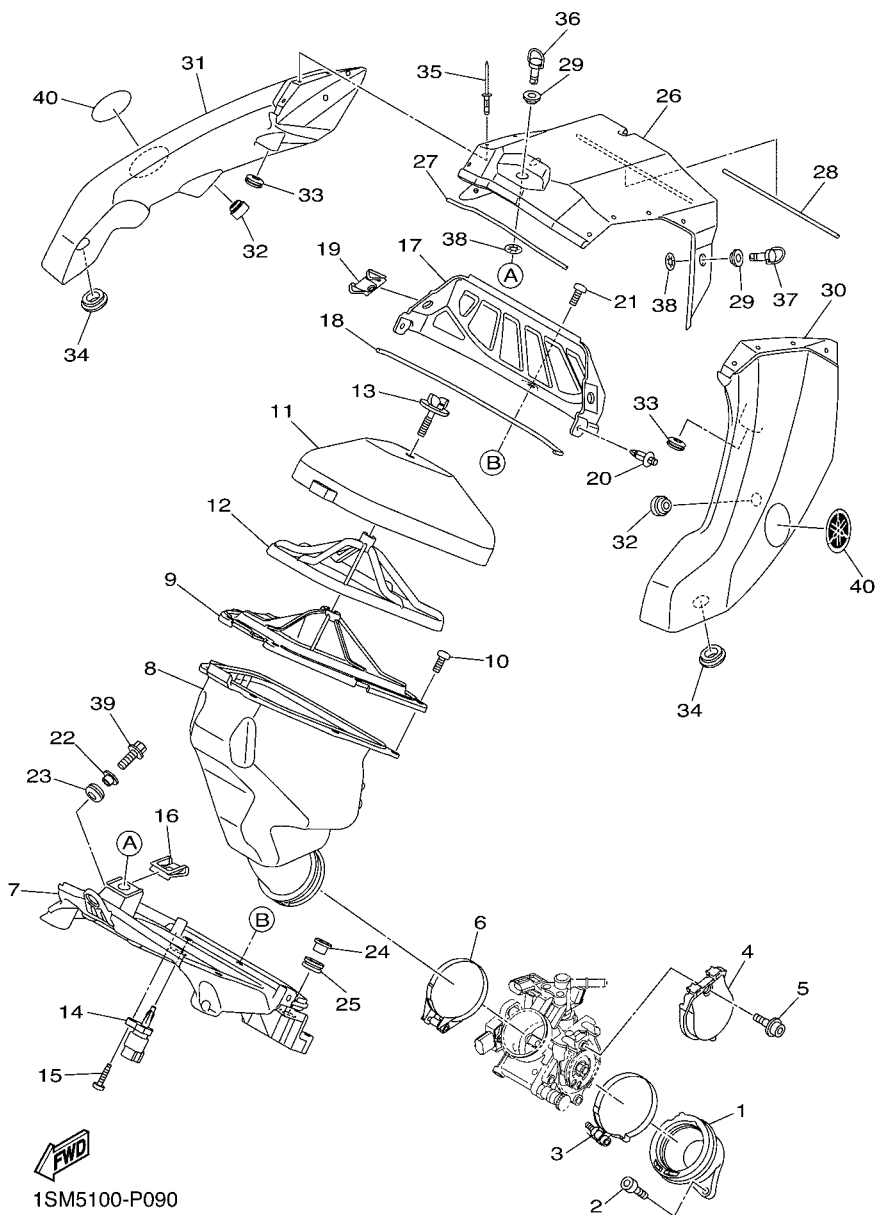
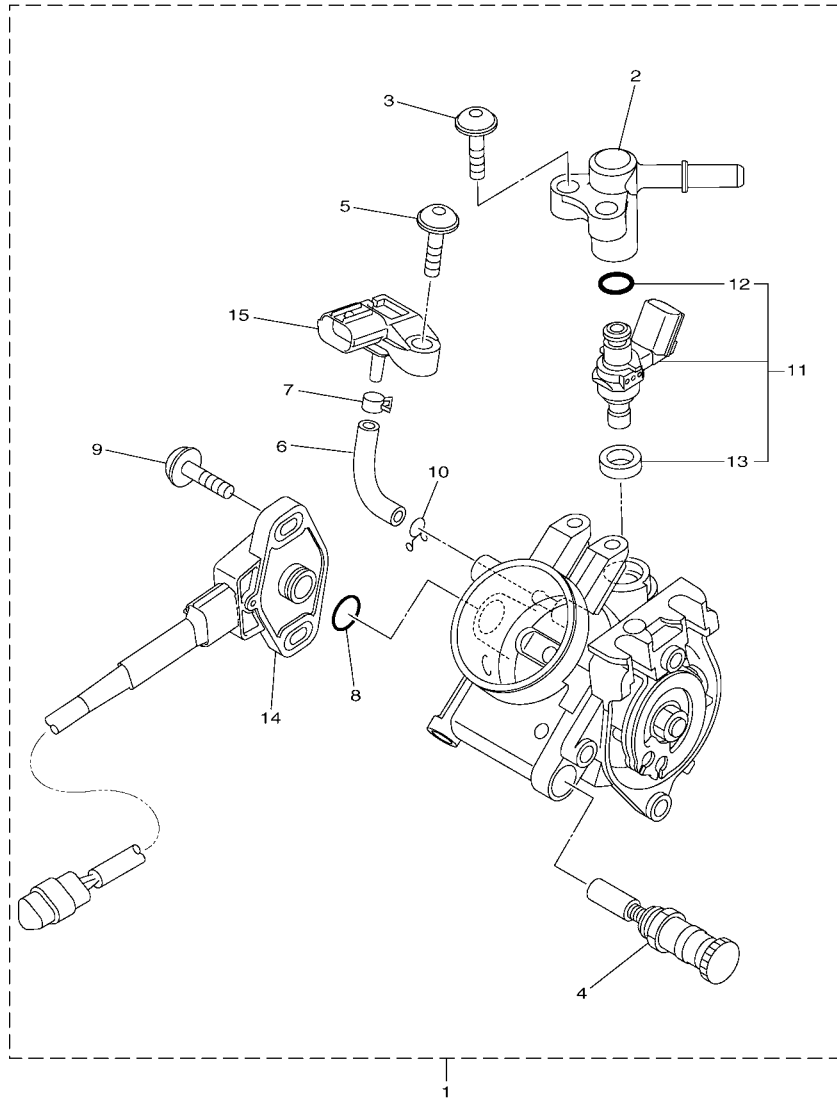


FIG. 9 INTAKE

REF. NO.	PART NO.	DESCRIPTION	ISM5	ISM6	ISM7	ISM8	REMARKS
27	1SL-14452-00	SEAL	1	1	1	1	
28	1SL-14457-00	SEAL	1	1	1	1	
29	90387-07045	COLLAR	3	3	3	3	
30	1SL-14437-00	DUCT	1	1	1	1	
31	1SL-1443A-00	DUCT	1	1	1	1	
32	90480-11298	GROMMET	2	2	2	2	
33	90480-12237	GROMMET	2	2	2	2	
34	90480-01558	GROMMET	2	2	2	2	
35	90267-41004	RIVET, BLIND	12	12	12	12	UR FOR DPBSE
	90267-40014	RIVET, BLIND	12			12	UR FOR PWS1
36	3FV-28386-00	HEAD	1	1	1	1	
37	1SL-28386-00	HEAD	2	2	2	2	
38	5TJ-21757-00	WASHER, SPECIAL 1	3	3	3	3	
39	90105-06203	BOLT, FLANGE	3	3	3	3	
40	1SL-2175C-00	TUNING FORK MARK	2	2	2	2	



  
1SM5100-P090

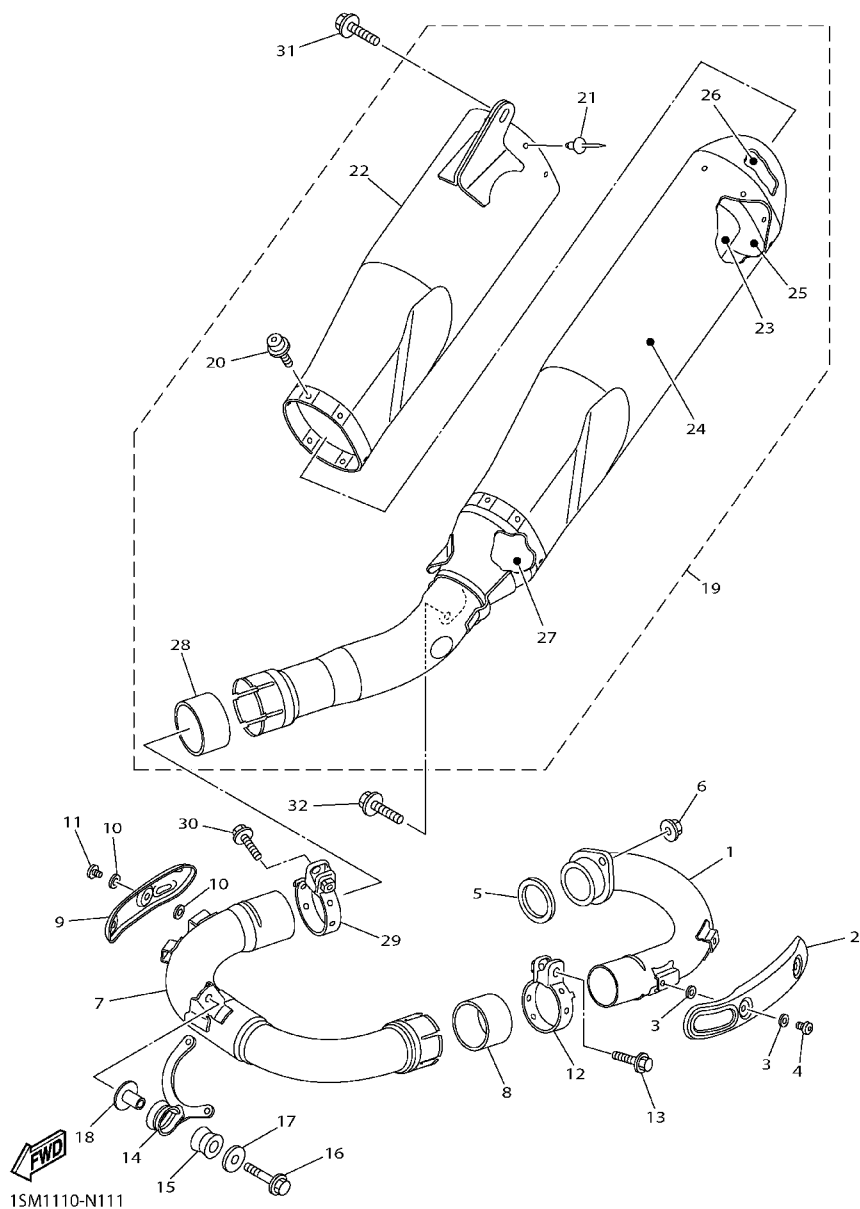


1SM1110-N100

FIG. 10 INTAKE 2

REF. NO.	PART NO.	DESCRIPTION	1SM5	1SM6	1SM7	1SM8	REMARKS
1	1SM-13750-10	THROTTLE BODY ASSY	1	1	1	1	
2	1SM-13938-00	.PIPE	1	1	1	1	
3	33D-14486-00	.SCREW, ROD	2	2	2	2	
4	1SL-14171-00	.PLUNGER, STARTER	1	1	1	1	
5	33D-14325-00	.SCREW, PAN HEAD	1	1	1	1	
6	33D-14348-00	.PIPE 1	1	1	1	1	
7	33D-13577-00	.CLIP	1	1	1	1	
8	1DX-14562-00	.O-RING	1	1	1	1	
9	1DX-14216-00	.SCREW	1	1	1	1	
10	3TJ-14137-40	.CLIP	1	1	1	1	
11	1SM-13761-00	.INJECTOR	1	1	1	1	
12	1SM-14147-00	..O-RING	1	1	1	1	
13	1SM-141A1-00	..SEAL RING	1	1	1	1	
14	1SL-85885-00	.THROTTLE SENSOR ASSY	1	1	1	1	
15	2C0-82380-00	.SENSOR, PRESSURE	1	1	1	1	

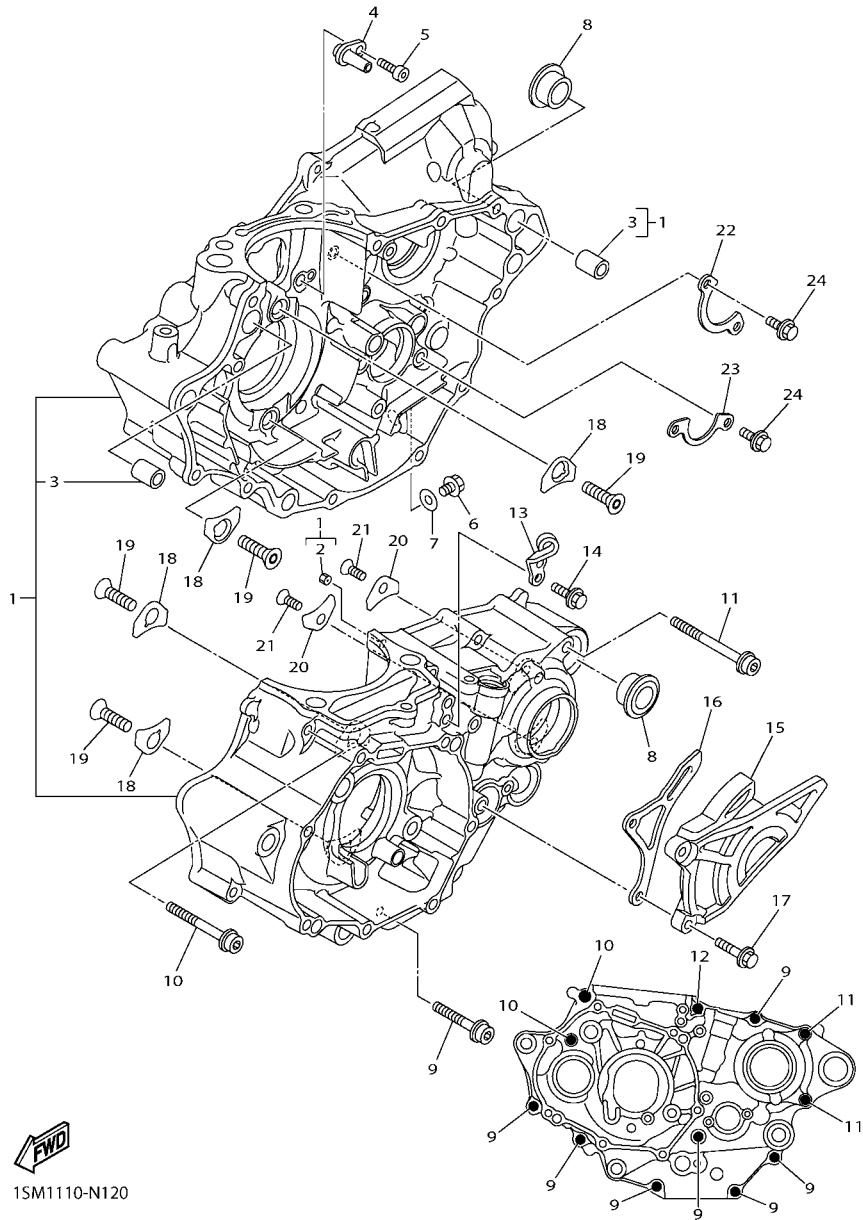
FIG. 11 EXHAUST



1SM1110-N111

REF. NO.	PART NO.	DESCRIPTION	1SM5	1SM6	1SM7	1SM8	REMARKS
1	1SM-14611-00	PIPE, EXHAUST 1	1	1	1	1	
2	1SL-14628-00	PROTECTOR, EXHAUST PIPE	1	1	1	1	
3	90201-05017	WASHER, PLATE	4	4	4	4	
4	98980-06008	SCREW, BIND	2	2	2	2	
5	5NL-14613-00	GASKET, EXHAUST PIPE	1	1	1	1	
6	95702-08500	NUT, FLANGE	2	2	2	2	
7	1SM-14621-00	PIPE, EXHAUST 2	1	1	1	1	
8	5PX-14755-00	GASKET, SILENCER	1	1	1	1	
9	1SL-1463B-00	PROTECTOR, EXT. PIPE 2	1	1	1	1	
10	90201-05017	WASHER, PLATE	4	4	4	4	
11	98980-06008	SCREW, BIND	2	2	2	2	
12	1SM-14788-00	BAND, SILENCER	1	1	1	1	
13	95024-08040	BOLT, FLG.(SMALL HEAD)	1	1	1	1	
14	1SM-14639-00	STAY, EXHAUST PIPE 1	1	1	1	1	
15	5VY-14747-00	DAMPER, MUFFLER	1	1	1	1	
16	90105-08137	BOLT, FLANGE	1	1	1	1	
17	90201-08061	WASHER, PLATE	1	1	1	1	
18	90387-08081	COLLAR	1	1	1	1	
19	1SM-14750-00	SILENCER ASSY	1				
	1SM-14750-10	SILENCER ASSY		1	1	1	
20	90110-05064	BOLT, HEXAGON SOCKET HEAD	6	6	6	6	
21	90267-48121	RIVET, BLIND	8	8	8	8	
22	1SM-1466G-00	BODY, SILENCER	1	1	1	1	
23	1SM-1469A-00	FIBER	1				
	1SM-1469A-10	FIBER		1	1	1	
24	1SM-1477E-00	FIBER 2	1				
	1SM-1477E-10	FIBER 2		1	1	1	

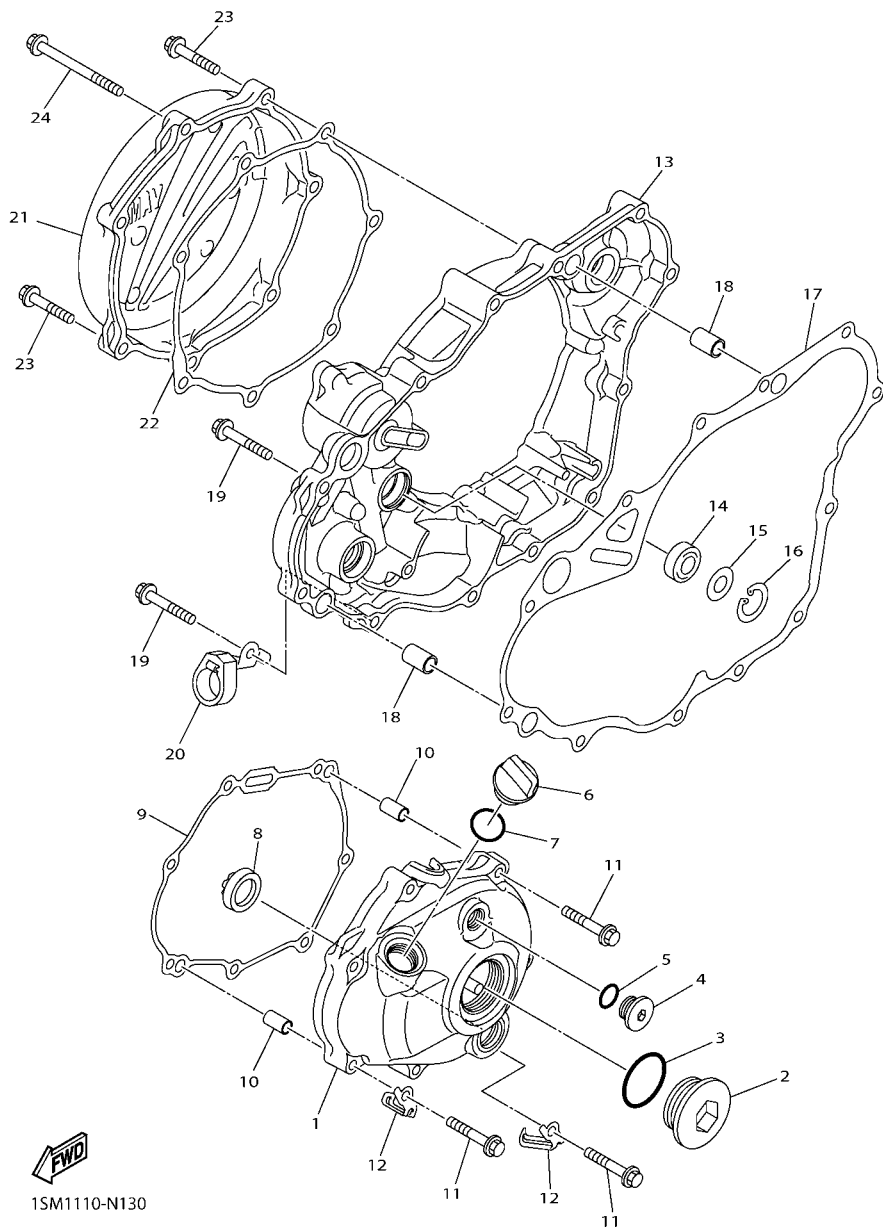




1SM1110-N120

FIG. 12 CRANKCASE

REF. NO.	PART NO.	DESCRIPTION	1SM5	1SM6	1SM7	1SM8	REMARKS
1	1SM-15100-09	CRANKCASE ASSY	1	1	1	1	
2	1SM-15138-00	.NOZZLE 1	1	1	1	1	
3	99530-14016	.PIN, DOWEL	2	2	2	2	
4	1SM-15155-00	NOZZLE 3	1	1	1	1	
5	90110-05032	BOLT, HEXAGON SOCKET HEAD	1	1	1	1	
6	95022-10016	BOLT, FLANGE	1	1	1	1	
7	90430-10188	GASKET	1	1	1	1	
8	90387-17015	COLLAR	2	2	2	2	
9	90110-06391	BOLT, HEXAGON SOCKET HEAD	7	7	7	7	
10	90110-06363	BOLT, HEXAGON SOCKET HEAD	2	2	2	2	
11	90110-06392	BOLT, HEXAGON SOCKET HEAD	2	2	2	2	
12	91317-06075	BOLT	1	1	1	1	
13	1SL-15441-00	HOLDER, CLUTCH CABLE	1	1	1	1	
14	90105-06099	BOLT, FLANGE	2	2	2	2	
15	1SL-15421-00	COVER, CRANKCASE 2	1	1	1	1	
16	1SL-17466-00	GUIDE, CHAIN	1	1	1	1	
17	90105-06189	BOLT, FLANGE	2	2	2	2	
18	18P-15383-00	PLATE, BEARING COVER	4	4	4	4	
19	90151-08007	SCREW, COUNTERSUNK	4	4	4	4	
20	4JT-15381-01	PLATE, BEARING COVER	2	2	2	2	
21	90149-06074	SCREW	2	2	2	2	
22	1SM-15388-00	PLATE, BEARING COVER	1	1	1	1	
23	1SL-18562-00	PLATE, STOPPER 2	1	1	1	1	
24	90105-06081	BOLT, FLANGE	4	4	4	4	



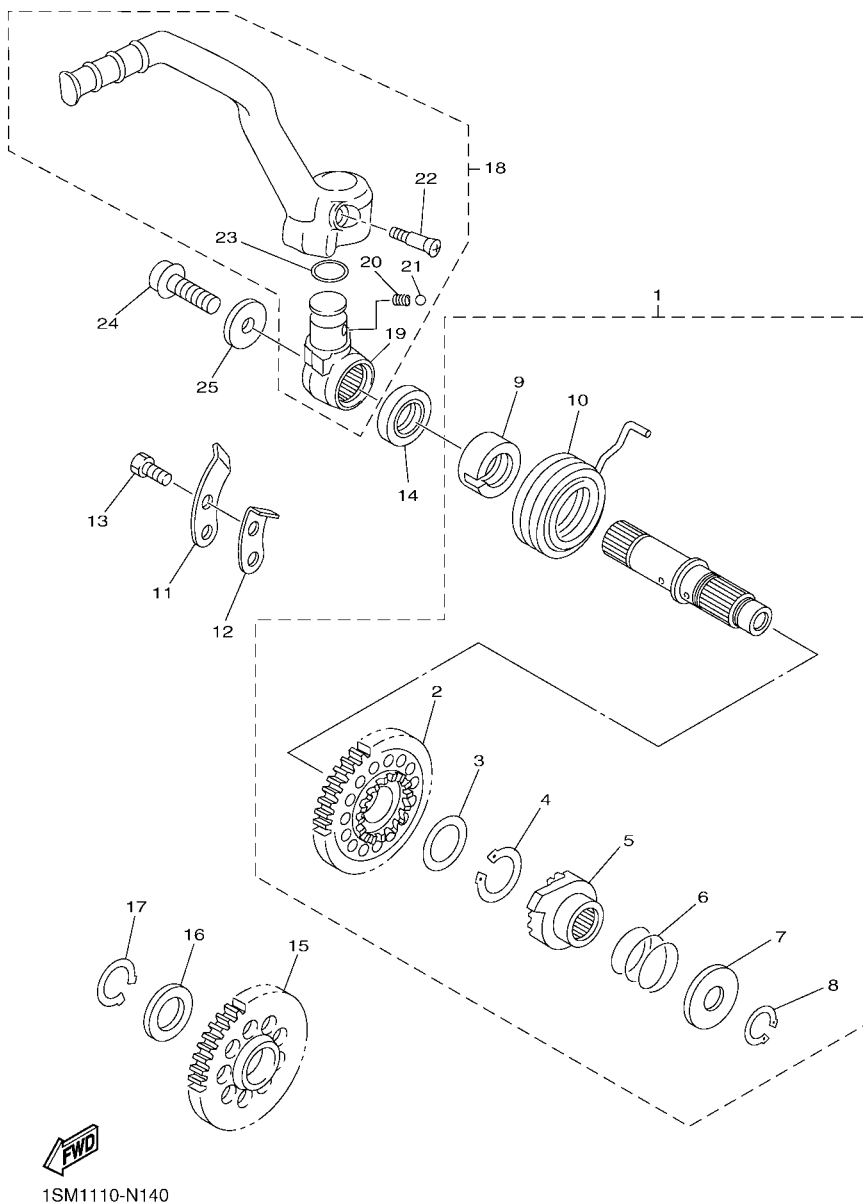
1SM1110-N130

FIG. 13 CRANKCASE COVER 1

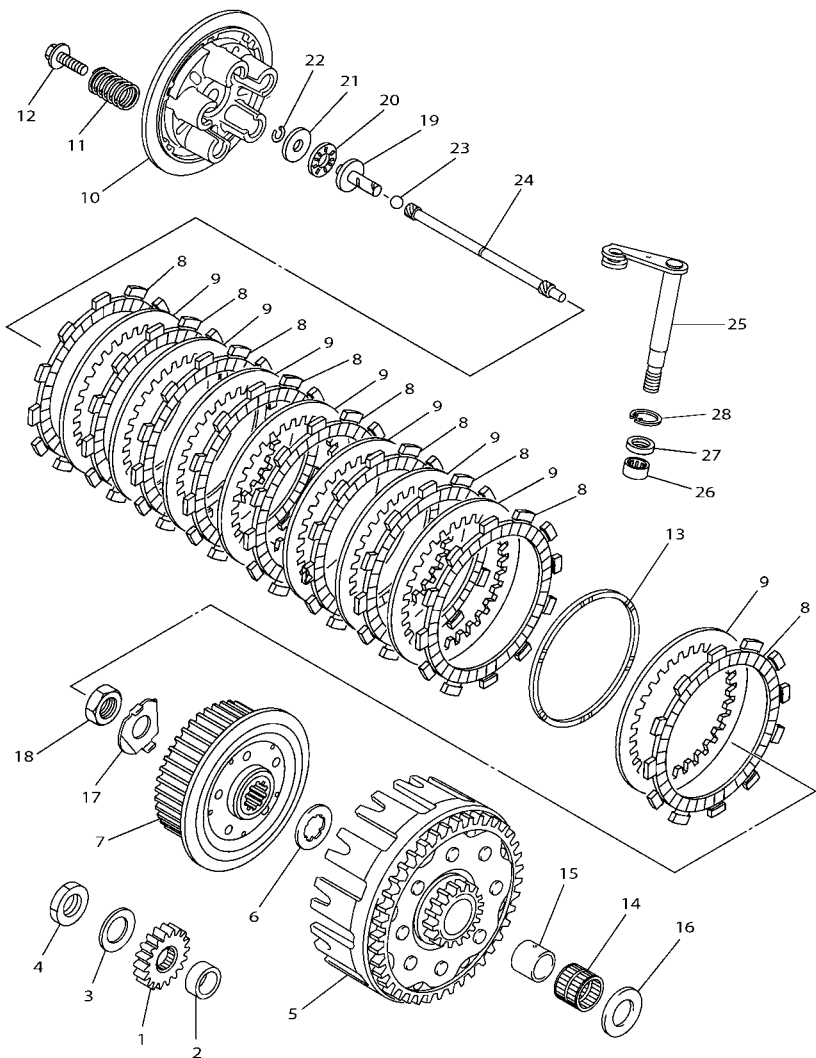
REF. NO.	PART NO.	DESCRIPTION	1SM5	1SM6	1SM7	1SM8	REMARKS
1	1SM-15411-00	COVER, CRANKCASE 1	1	1	1	1	
2	90340-36002	PLUG, STRAIGHT SCREW	1	1	1	1	
3	93210-357A3	O-RING	1	1	1	1	
4	90340-14011	PLUG, STRAIGHT SCREW	1	1	1	1	
5	93210-14369	O-RING	1	1	1	1	
6	3Y1-15363-10	PLUG, OIL	1	1	1	1	
7	93210-19123	O-RING	1	1	1	1	
8	3Y1-15361-00	GAUGE, LEVEL	1	1	1	1	
9	1SM-15451-00	GASKET, CRANKCASE COVER 1	1	1	1	1	
10	99530-08016	PIN, DOWEL	2	2	2	2	
11	95022-06030	BOLT, FLANGE	7	7	7	7	
12	90465-08062	CLAMP	2	2	2	2	
13	1SM-15431-00	COVER, CRANKCASE 3	1	1	1	1	
14	93101-14164	OIL SEAL	1	1	1	1	
15	90201-15701	WASHER, PLATE (T=1.0)	1	1	1	1	
16	99009-22500	CIRCLIP	1	1	1	1	
17	1SM-15462-00	GASKET, CRANKCASE COVER 3	1	1	1	1	
18	99530-12016	PIN, DOWEL	2	2	2	2	
19	90105-06102	BOLT, FLANGE	11	11	11	11	
20	17D-15378-00	HOLDER	1	1	1	1	
21	1SM-15415-00	COVER, GENERATOR	1	1	1	1	
22	1SM-15453-00	GASKET	1	1	1	1	
23	95022-06025	BOLT, FLANGE	6	6	6	6	
24	95022-06060	BOLT, FLANGE	1	1	1	1	

FIG. 14 STARTER

REF. NO.	PART NO.	DESCRIPTION	ISM5	ISM6	ISM7	ISM8	REMARKS
1	1SM-15601-00	KICK SHAFT ASSY	1	1	1	1	
2	1SM-15641-00	.GEAR, KICK	1	1	1	1	
3	90201-20685	.WASHER, PLATE (T=0.5)	1	1	1	1	
4	93410-20038	.CIRCLIP	1	1	1	1	
5	2S2-15671-00	.WHEEL, RATCHET	1	1	1	1	
6	90501-160A2	.SPRING, COMPRESSION	1	1	1	1	
7	90201-167P7	.WASHER, PLATE	1	1	1	1	
8	99009-16400	.CIRCLIP	1	1	1	1	
9	5NL-15664-00	.GUIDE, SPRING	1	1	1	1	
10	90508-30743	.SPRING, TORSION	1	1	1	1	
11	214-15674-00	GUIDE, RATCHET WHEEL	1	1	1	1	
12	2NX-15668-00	STOPPER	1	1	1	1	
13	90101-06044	BOLT	2	2	2	2	
14	93102-18278	OIL SEAL	1	1	1	1	
15	1SM-15651-00	GEAR, KICK IDLE	1	1	1	1	
16	90201-177G4	WASHER, PLATE	1	1	1	1	
17	99009-17400	CIRCLIP	1	1	1	1	
18	1SM-15620-00	KICK CRANK ASSY	1	1	1	1	
19	1SM-15621-00	.BOSS, KICK CRANK	1	1	1	1	
20	90501-147A5	.SPRING, COMPRESSION	1	1	1	1	
21	93507-32009	.BALL	1	1	1	1	
22	90151-06045	.SCREW, COUNTERSUNK	1	1	1	1	
23	93210-17570	.O-RING	1	1	1	1	
24	90110-08051	BOLT, HEXAGON SOCKET HEAD	1	1	1	1	
25	90201-08048	WASHER, PLATE	1	1	1	1	





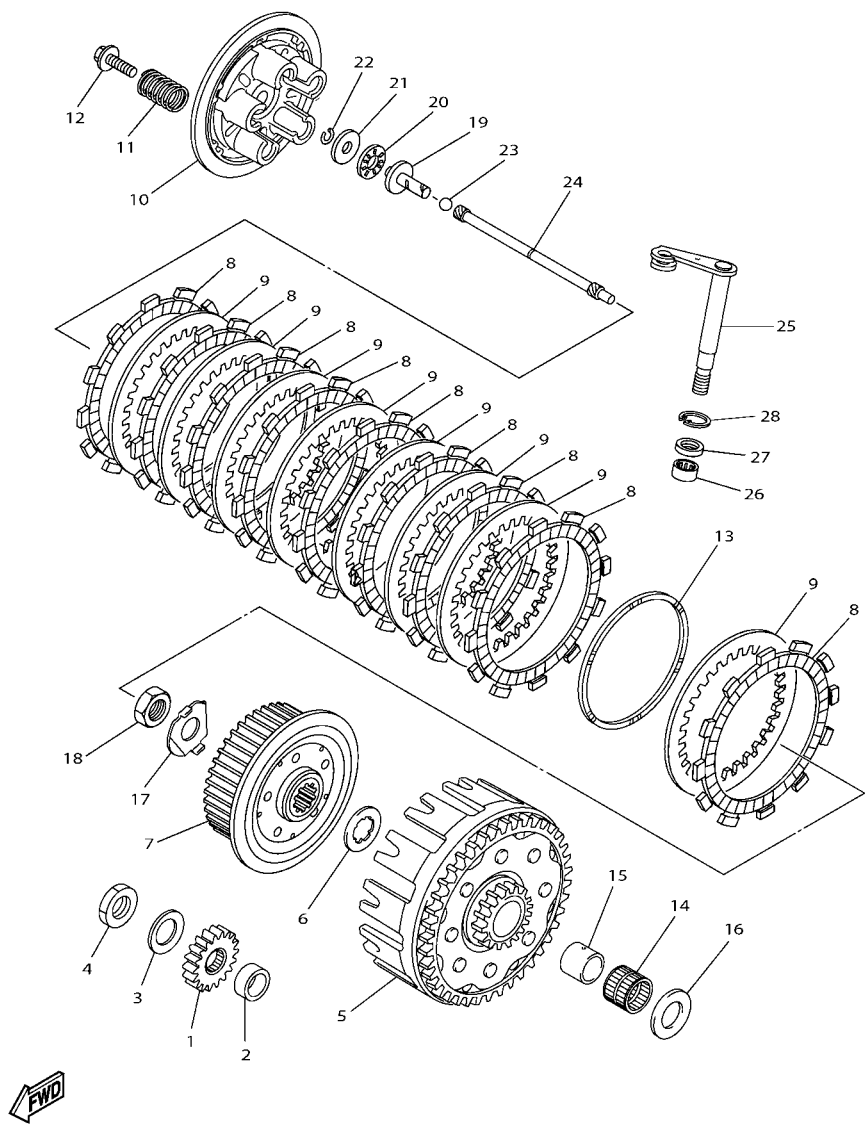


1SM1110-N150

FIG. 15 CLUTCH

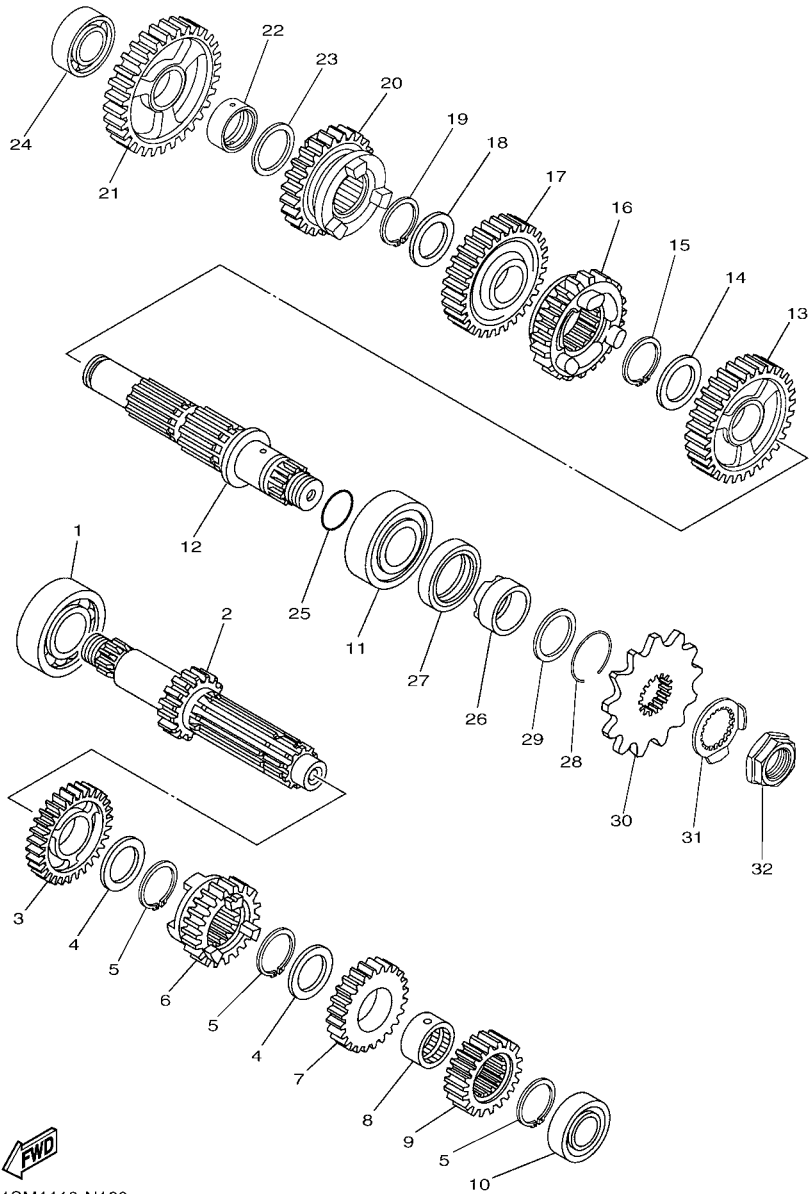
REF. NO.	PART NO.	DESCRIPTION	1SM5	1SM6	1SM7	1SM8	REMARKS
1	1SM-16111-00	GEAR, PRIMARY DRIVE	1	1	1	1	
2	90387-19008	COLLAR	1	1	1	1	
3	90208-16019	WASHER, CONICAL SPRING	1	1	1	1	
4	90170-16003	NUT	1	1	1	1	
5	1SM-16150-00	PRIMARY DRIVEN GEAR COMP.	1	1	1	1	
6	1SM-16154-00	PLATE, THRUST 1	1	1	1	1	
7	5NL-16371-40	BOSS, CLUTCH	1	1	1	1	
8	5XC-16321-00	PLATE, FRICTION	9	9	9	9	
9	5NL-16325-00	PLATE, CLUTCH 2	8	8	8	8	
10	1SM-16351-00	PLATE, PRESSURE 1	1	1	1	1	
11	90501-230A6	SPRING, COMPRESSION	5	5	5	5	
12	90159-06029	SCREW, WITH WASHER	5	5	5	5	
13	1SM-16383-00	SPRING., CUSHION	1	1	1	1	
14	93310-225N0	BEARING	1	1	1	1	
15	1SM-16181-00	SPACER 1	1	1	1	1	
16	90201-20611	WASHER, PLATE	1	1	1	1	
17	90215-16289	WASHER, LOCK	1	1	1	1	
18	90170-16326	NUT	1	1	1	1	
19	1SM-16356-00	ROD, PUSH 1	1	1	1	1	
20	93340-21008	BEARING	1	1	1	1	
21	90201-080H1	WASHER, PLATE	1	1	1	1	
22	93440-07182	CIRCLIP	1	1	1	1	
23	93511-32027	BALL	1	1	1	1	
24	1SM-16357-00	ROD, PUSH 2	1	1	1	1	
25	1SM-16381-00	PUSH LEVER COMP.	1	1	1	1	
26	93317-11096	BEARING	1	1	1	1	
27	93102-10008	OIL SEAL	1	1	1	1	

FIG. 15 CLUTCH



1SM1110-N150

REF. NO.	PART NO.	DESCRIPTION	1SM5	1SM6	1SM7	1SM8	REMARKS
28	99009-18500	CIRCLIP	1	1	1	1	



1SM1110-N160

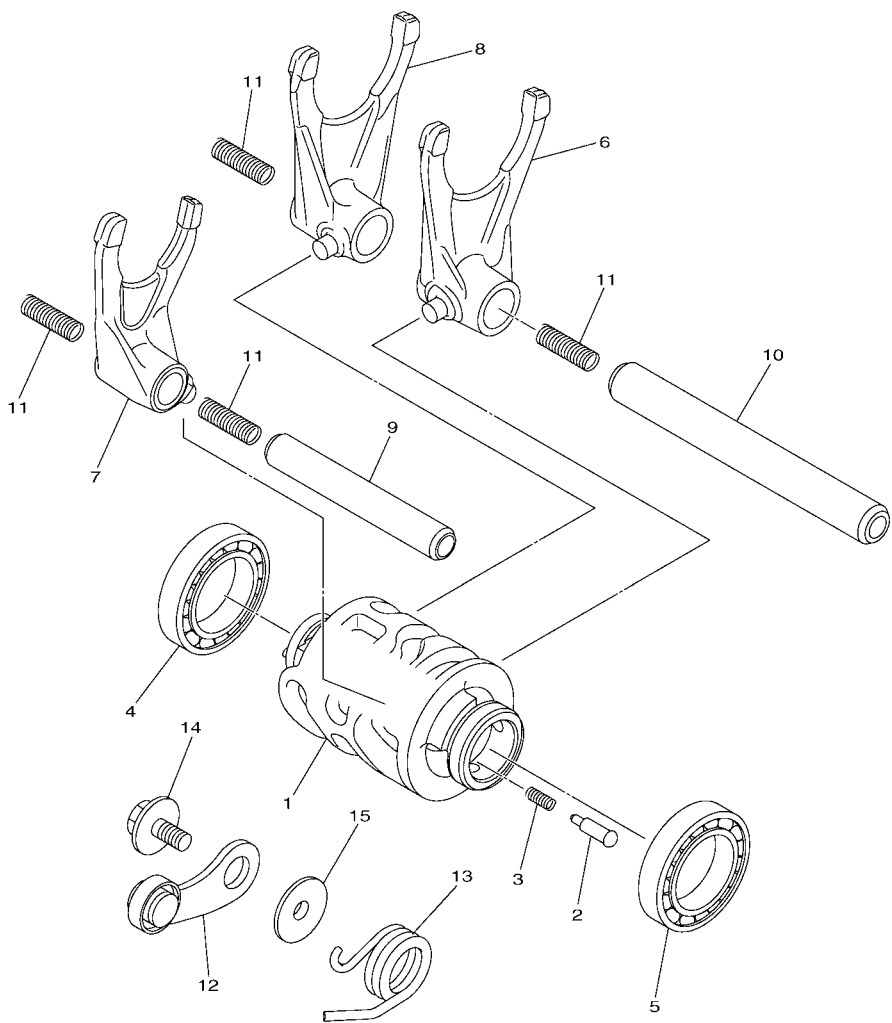
FIG. 16 TRANSMISSION

REF. NO.	PART NO.	DESCRIPTION	1SM5	1SM6	1SM7	1SM8	REMARKS
1	93306-00426	BEARING	1	1	1	1	
2	1SM-17411-00	AXLE,MAIN(14T)	1	1	1	1	
3	1SM-17151-00	GEAR, 5TH PINION (24T)	1	1	1	1	
4	90209-20008	WASHER	2	2	2	2	
5	93410-22039	CIRCLIP	3	3	3	3	
6	1SM-17131-00	GEAR, 3RD PINION (18T)	1	1	1	1	
7	1SM-17141-00	GEAR, 4TH PINION (18T)	1	1	1	1	
8	90387-20006	COLLAR	1	1	1	1	
9	1SM-17121-00	GEAR, 2ND PINION (16T)	1	1	1	1	
10	93306-20336	BEARING	1	1	1	1	
11	93306-27209	BEARING	1	1	1	1	
12	1SM-1742A-00	DRIVE AXLE ASSY.,2	1	1	1	1	
13	1SM-17221-00	GEAR, 2ND WHEEL (28T)	1	1	1	1	
14	90209-23012	WASHER	1	1	1	1	
15	93410-26067	CIRCLIP	1	1	1	1	
16	1SM-17241-00	GEAR, 4TH WHEEL (22T)	1	1	1	1	
17	17D-17231-10	GEAR, 3RD WHEEL (26T)	1	1	1	1	
18	90209-20008	WASHER	1	1	1	1	
19	93410-22039	CIRCLIP	1	1	1	1	
20	1SM-17251-00	GEAR, 5TH WHEEL (25T)	1	1	1	1	
21	1SM-17211-00	GEAR, 1ST WHEEL (30T)	1	1	1	1	
22	90387-17012	COLLAR	1	1	1	1	
23	90201-177G4	WASHER, PLATE	1	1	1	1	
24	93306-20351	BEARING	1	1	1	1	
25	93210-196A4	O-RING	1	1	1	1	
26	90387-22033	COLLAR	1	1	1	1	
27	93102-28012	OIL SEAL	1	1	1	1	

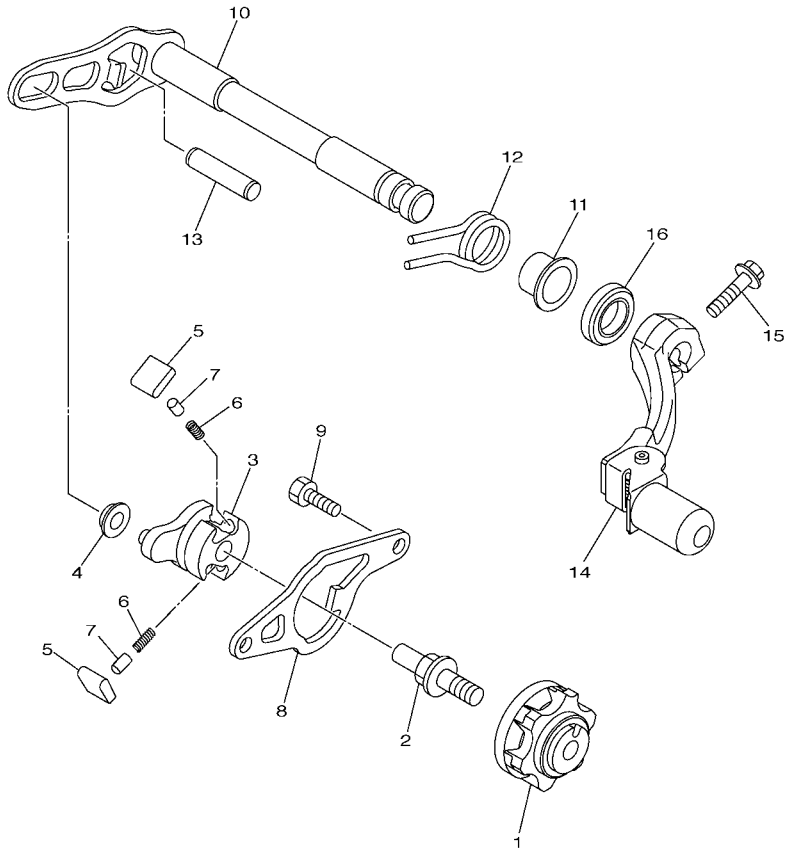


**FIG. 17 SHIFT CAM & FORK**

REF. NO.	PART NO.	DESCRIPTION	ISM5	ISM6	ISM7	ISM8	REMARKS
1	1SM-18541-00	CAM, SHIFT	1	1	1	1	
2	3D7-18542-00	POINT, NEUTRAL	1	1	1	1	
3	90501-06022	SPRING, COMPRESSION	1	1	1	1	
4	93306-90409	BEARING	1	1	1	1	
5	93306-80502	BEARING	1	1	1	1	
6	1SM-18511-00	FORK, SHIFT 1	1	1	1	1	
7	1SM-18512-00	FORK, SHIFT 2	1	1	1	1	
8	1SM-18513-00	FORK, SHIFT 3	1	1	1	1	
9	1SL-18531-00	BAR, SHIFT FORK GUIDE 1	1	1	1	1	
10	1SL-18535-00	BAR, SHIFT FORK GUIDE 2	1	1	1	1	
11	90501-064L1	SPRING, COMPRESSION	4	4	4	4	
12	1SL-18140-01	STOPPER LEVER ASSY	1	1	1	1	
13	90508-26080	SPRING, TORSION	1	1	1	1	
14	90159-06027	SCREW, WITH WASHER	1	1	1	1	
15	33D-18175-00	SPACER	1	1	1	1	



1SM1110-N170



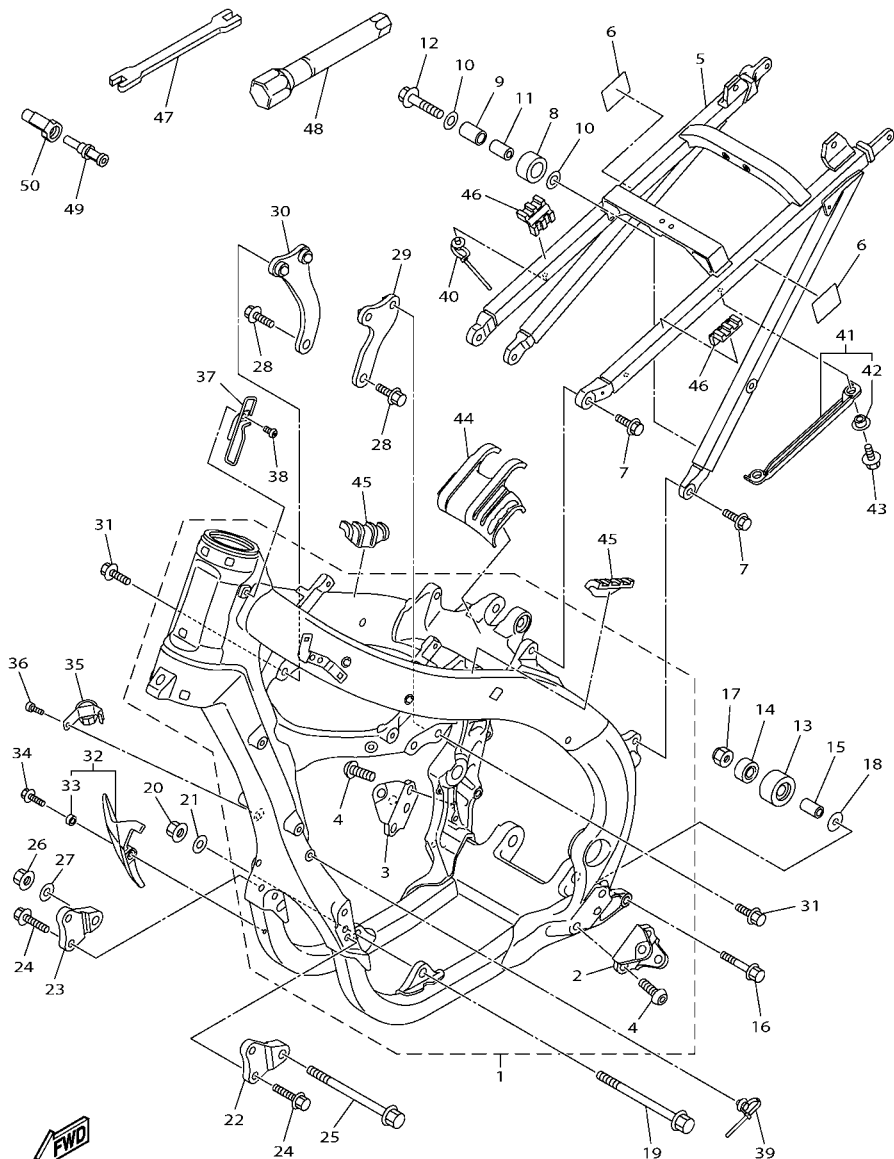
1SL1110-N180

FIG. 18 SHIFT SHAFT

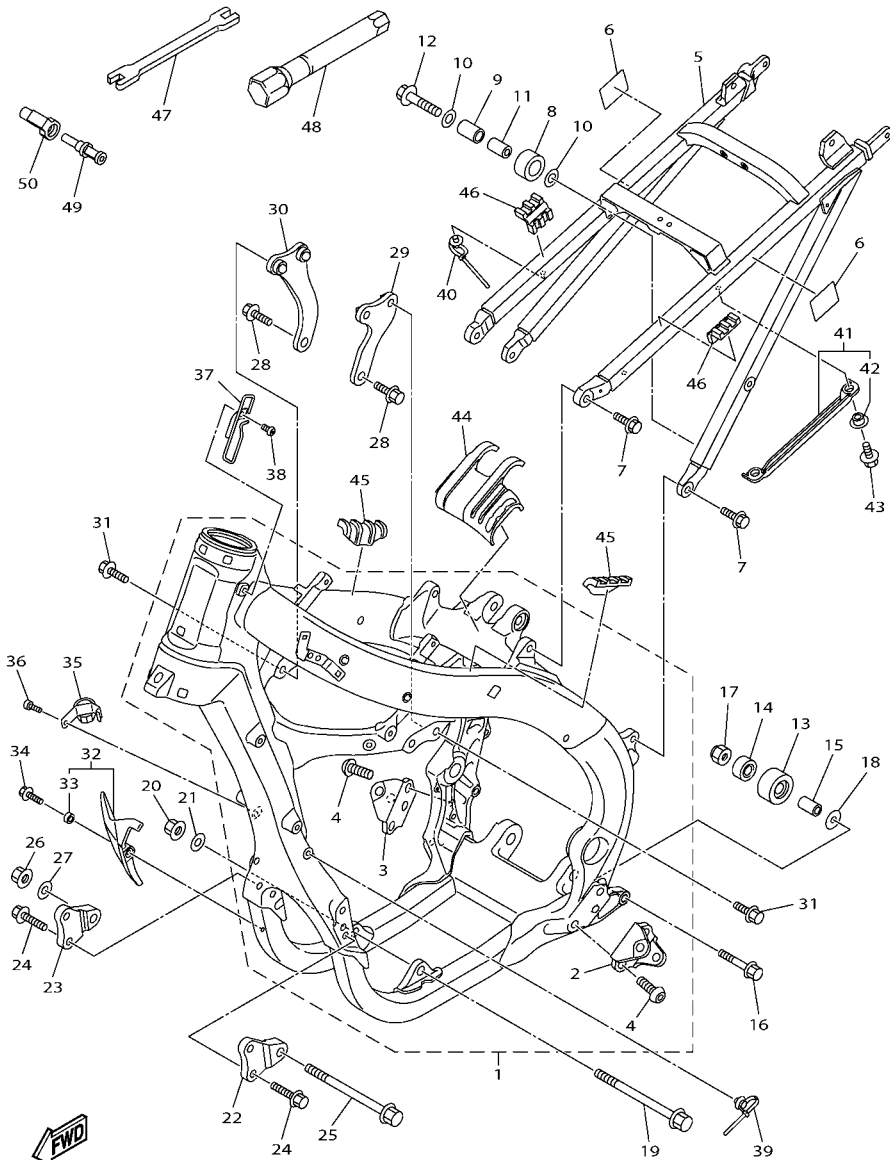
REF. NO.	PART NO.	DESCRIPTION	1SM5	1SM6	1SM7	1SM8	REMARKS
1	1SL-18185-00	SEGMENT	1	1	1	1	
2	3XJ-18173-10	PIN, SHIFT	1	1	1	1	
3	1SL-18122-00	LEVER, SHIFT 2	1	1	1	1	
4	3XJ-18178-00	ROLLER, SHIFT LEVER	1	1	1	1	
5	3XJ-18182-00	PAWL, SHIFTER	2	2	2	2	
6	90501-052G5	SPRING, COMPRESSION	2	2	2	2	
7	3XJ-18184-00	PIN, PAWL	2	2	2	2	
8	1SL-18172-00	GUIDE, SHIFT	1	1	1	1	
9	90101-06041	BOLT	2	2	2	2	
10	1SM-18101-00	SHIFT SHAFT ASSY	1	1	1	1	
11	90387-14020	COLLAR	1	1	1	1	
12	90508-29023	SPRING, TORSION	1	1	1	1	
13	93608-33002	PIN, DOWEL	1	1	1	1	
14	1SL-18110-00	SHIFT PEDAL ASSY	1	1	1	1	
15	90119-06M12	BOLT, WITH WASHER	1	1	1	1	
16	93109-14010	OIL SEAL	1	1	1	1	

FIG. 19 FRAME

REF. NO.	PART NO.	DESCRIPTION	1SM5	1SM6	1SM7	1SM8	REMARKS
1	1SL-21101-00	FRONT FRAME COMP.	1	1	1	1	
2	17D-21447-00	.BRACKET, FOOTREST	1	1	1	1	
3	17D-21448-00	.BRACKET, FOOTREST	1	1	1	1	
4	90149-10031	.SCREW	4	4	4	4	
5	1SL-21190-00	REAR FRAME COMP.	1	1	1	1	
6	33D-23472-00	PROTECTOR	2	2	2	2	
7	90105-08230	BOLT, FLANGE	4	4	4	4	
8	30X-22178-00	TENSIONER	1	1	1	1	
9	4V4-22184-00	BUSH	1	1	1	1	
10	90201-08045	WASHER, PLATE	2	2	2	2	
11	90387-08041	COLLAR	1	1	1	1	
12	95022-08040	BOLT, FLANGE	1	1	1	1	(KYB)
13	3JD-22178-20	TENSIONER	1	1	1	1	
14	93300-60839	BEARING	1	1	1	1	
15	90387-086N4	COLLAR	1	1	1	1	
16	90105-08232	BOLT, FLANGE	1	1	1	1	
17	90185-08009	NUT, SELF-LOCKING	1	1	1	1	
18	90201-08043	WASHER, PLATE	1	1	1	1	
19	90105-10176	BOLT, FLANGE	1	1	1	1	
20	90179-10658	NUT	1	1	1	1	
21	90201-10045	WASHER, PLATE	1	1	1	1	
22	1SM-21417-00	BRACKET, FRONT LOWER 1	1	1	1	1	
23	1SM-21418-00	BRACKET, FRONT LOWER 2	1	1	1	1	
24	90105-08143	BOLT, FLANGE	4	4	4	4	
25	90105-10443	BOLT, FLANGE	1	1	1	1	
26	90179-10658	NUT	1	1	1	1	
27	90201-10025	WASHER, PLATE	1	1	1	1	



1SM1110-N190



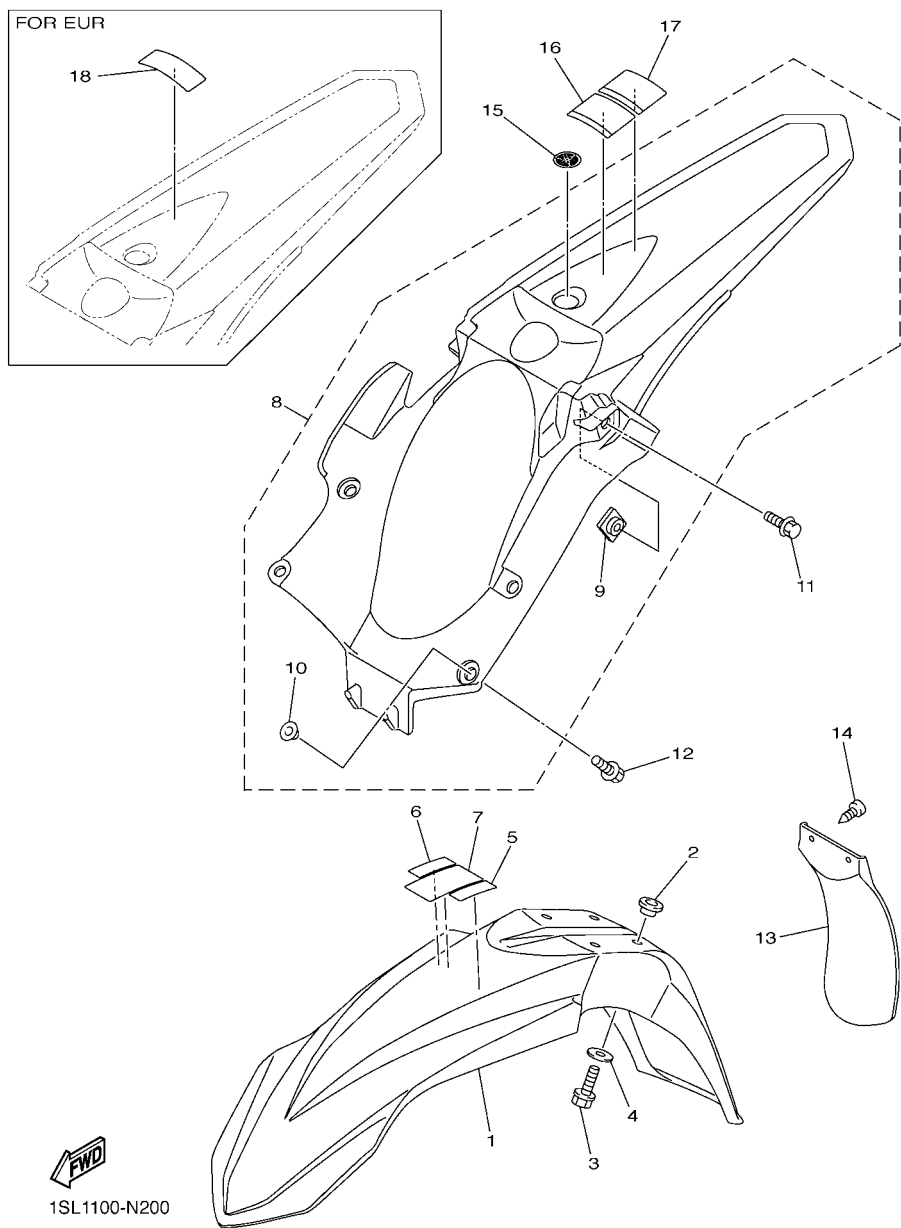
1SM1110-N190

FIG. 19 FRAME

REF. NO.	PART NO.	DESCRIPTION	1SM5	1SM6	1SM7	1SM8	REMARKS
28	90105-10189	BOLT, FLANGE	2	2	2	2	
29	1SM-21425-00	BRACKET, REAR UPPER 1	1	1	1	1	
30	1SM-21426-00	BRACKET, REAR UPPER 2	1	1	1	1	
31	90105-08143	BOLT, FLANGE	4	4	4	4	
32	1SM-21471-00	PROTECTOR, ENGINE	1	1	1	1	
33	90387-06106	.COLLAR	1	1	1	1	
34	90105-06203	BOLT, FLANGE	1	1	1	1	
35	1SM-21335-00	CLAMP, WIRE HARNESS 1	1	1	1	1	
36	91312-05008	BOLT	1	1	1	1	
37	1SL-21163-00	HOLDER, CLUTCH CABLE	1	1	1	1	
38	92012-06010	BOLT, BUTTON HEAD	1	1	1	1	
39	90464-31002	CLAMP	1	1	1	1	
40	90464-31002	CLAMP	1	1	1	1	
41	1SL-2171E-00	COVER, SIDE 5	1	1	1	1	
42	90387-065T2	.COLLAR	2	2	2	2	
43	95022-06016	BOLT, FLANGE	2	2	2	2	
44	1SL-24181-00	DAMPER, LOCATING 1	1	1	1	1	
45	33D-24182-00	DAMPER, LOCATING 2	2	2	2	2	
46	33D-24183-00	DAMPER, LOCATING 3	2	2	2	2	
47	5ET-28166-10	WRENCH, HEXAGON	1	1	1	1	
48	17D-2814F-00	BOX, SPARK PLUG	1	1	1	1	
49	18P-2467E-00	CAP	1	1	1	1	
50	18P-2464V-00	CASE, CAP	1	1	1	1	



FIG. 20 FENDER



1SL1100-N200

REF. NO.	PART NO.	DESCRIPTION	1SM5	1SM6	1SM7	1SM8	REMARKS
1	17D-21511-50	FENDER, FRONT	1	1	1	1	UR FOR DPBSE
	17D-21511-60	FENDER, FRONT	1			1	UR FOR PWS1
2	90387-06259	COLLAR	4	4	4	4	
3	90105-06127	BOLT, FLANGE	4	4	4	4	
4	90201-06108	WASHER, PLATE	4	4	4	4	
5	3FB-2415E-02	LABEL, CAUTION	1				
	3FB-2415E-C1	LABEL, CAUTION			1		JAPANESE
6	3FB-2415E-12	LABEL, CAUTION	1				
7	4SR-2416E-00	LABEL, CAUTION CANADA	1				
8	1SL-21610-00	REAR FENDER COMP.	1	1	1	1	UR FOR DPBSE
	1SL-21610-10	REAR FENDER COMP.	1			1	UR FOR PWS1
9	5XE-21635-10	.NUT, REAR FENDER	2	2	2	2	
10	5BE-21749-00	.COLLAR	4	4	4	4	
11	90105-06100	BOLT, FLANGE	2	2	2	2	
12	90119-06268	BOLT, WITH WASHER	4	4	4	4	
13	17D-21642-00	GUARD, FLAP	1	1	1	1	
14	97702-60016	SCREW, TAPPING	2	2	2	2	
15	5FK-2175C-30	TUNING FORK MARK	1	1	1	1	
16	5PA-2118K-00	LABEL, CAUTION	1			1	
	5PA-2118K-20	LABEL, CAUTION			1		
17	5PA-2118K-10	LABEL, CAUTION	1				
18	5PG-2816R-00	LABEL, WARNING GENERAL INFO.		1			

FIG. 21 SIDE COVER

REF. NO.	PART NO.	DESCRIPTION	ISM5	ISM6	ISM7	ISM8	REMARKS
1	1SL-21710-00	SIDE COVER ASSY 1	1	1	1	1	
2	90387-08057	.COLLAR	1	1	1	1	
3	5TA-21749-00	.COLLAR	1	1	1	1	
4	1SL-2176M-00	.HOOK	1	1	1	1	
5	97702-40012	.SCREW, TAPPING	5	5	5	5	
6	90105-08230	BOLT, FLANGE	1	1	1	1	
7	90119-06096	BOLT, WITH WASHER	1	1	1	1	
8	1SL-21720-00	SIDE COVER ASSY 2	1	1	1	1	
9	90387-08057	.COLLAR	1	1	1	1	
10	5BE-21749-00	.COLLAR	1	1	1	1	
11	5TA-21749-00	.COLLAR	1	1	1	1	
12	1SL-21719-00	.GROMMET	3	3	3	3	
13	1DX-21746-00	.DAMPER	1	1	1	1	
14	90387-06M31	.COLLAR	1	1	1	1	
15	90105-08230	BOLT, FLANGE	1	1	1	1	
16	90119-06096	BOLT, WITH WASHER	2	2	2	2	
17	1SM-217R0-20	SIDE COVER INSERT ASSY. 3	1	1	1	1	UR FOR DPBSE
	1SM-217R0-30	SIDE COVER INSERT ASSY. 3	1			1	UR FOR PWS1
	1SL-21730-00	SIDE COVER ASSY 3(WO/GRAPHIC)	1	1	1	1	AP PWS1
18	17D-21749-00	.COLLAR	2	2	2	2	
19	90387-11009	.COLLAR	1	1	1	1	
20	90387-06372	.COLLAR	1	1	1	1	
21	1SL-21748-00	.COLLAR	1	1	1	1	
22	90480-10068	.GROMMET	1	1	1	1	
23	1SM-217S0-20	SIDE COVER INSERT ASSY. 4	1	1	1	1	UR FOR DPBSE
	1SM-217S0-30	SIDE COVER INSERT ASSY. 4	1			1	UR FOR PWS1
	1SL-21740-01	SIDE COVER ASSY 4	1	1	1	1	AP PWS1

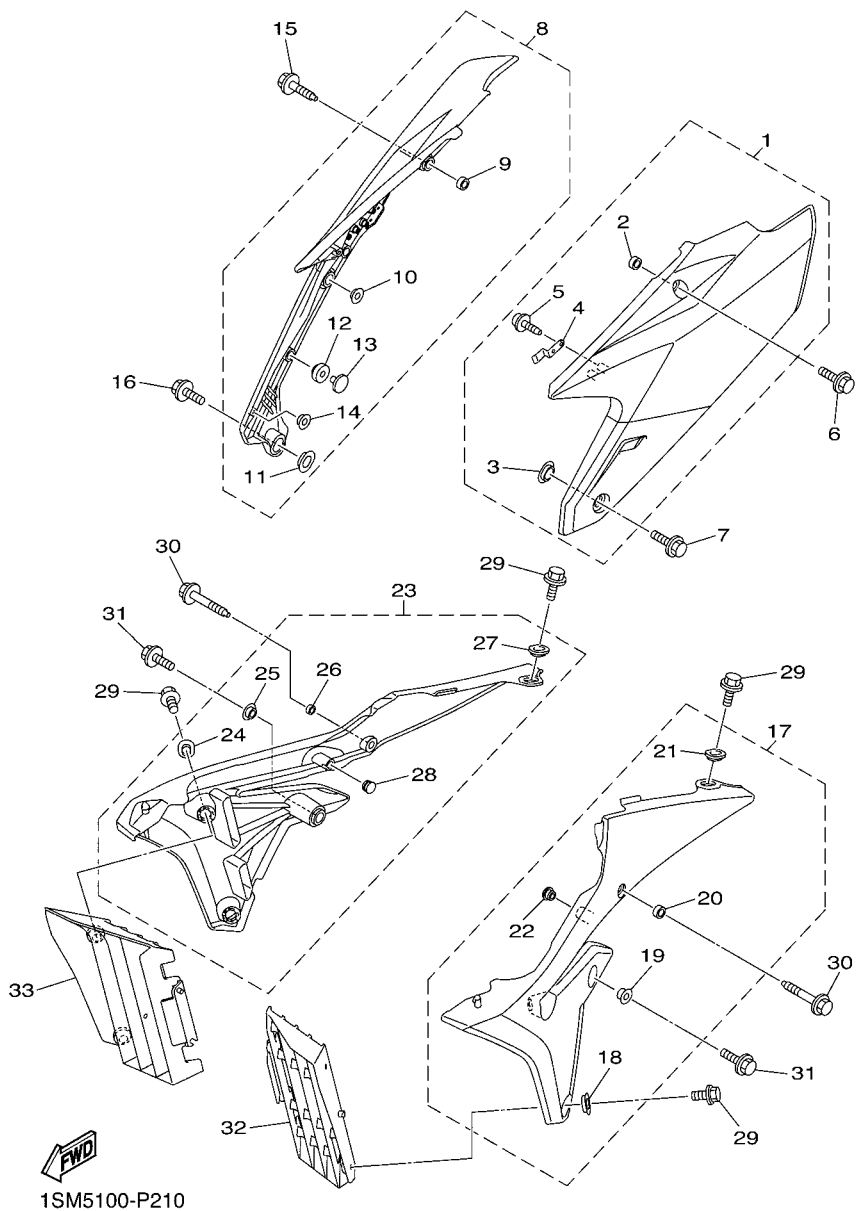
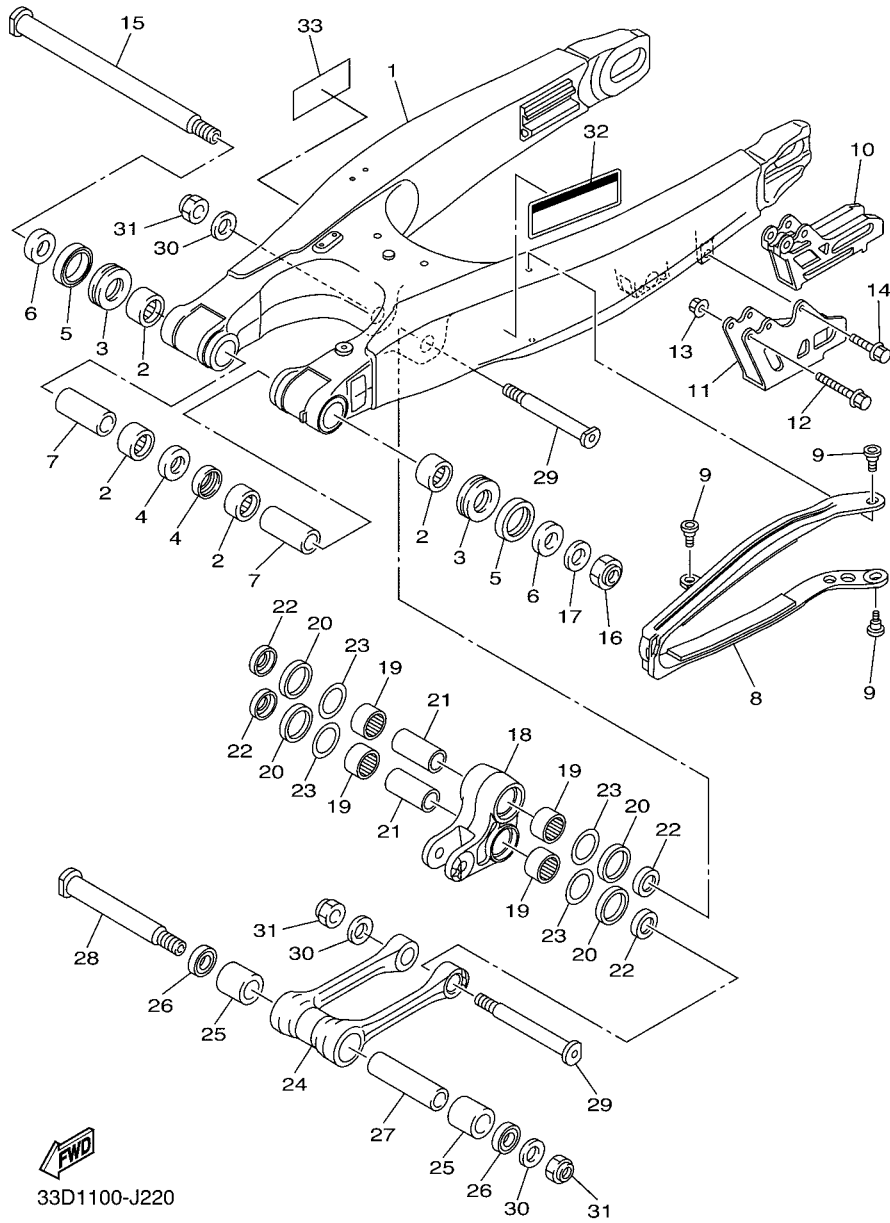




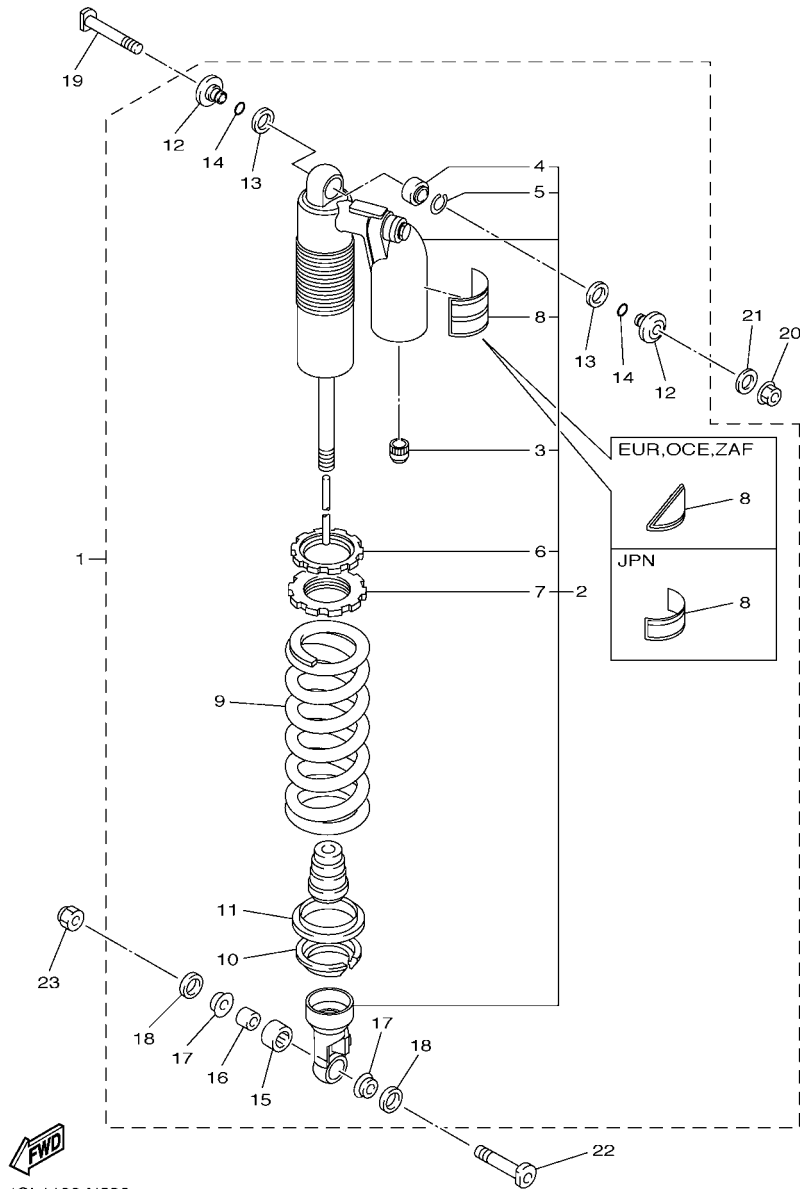
FIG. 22 REAR ARM



33D1100-J220

REF. NO.	PART NO.	DESCRIPTION	ISM5	ISM6	ISM7	ISM8	REMARKS
1	1SL-22110-00	REAR ARM COMP.	1	1	1	1	
2	93317-22262	BEARING	4	4	4	4	
3	93342-22217	BEARING	2	2	2	2	
4	93106-22002	OIL SEAL	2	2	2	2	
5	93109-28043	OIL SEAL	2	2	2	2	
6	90387-17016	COLLAR	2	2	2	2	
7	90387-1714S	COLLAR	2	2	2	2	
8	34P-22151-01	SEAL, GUARD	1	1	1	1	
9	1C3-22969-90	SCREW, 1	3	3	3	3	
10	2S2-22199-70	SUPPORT, CHAIN	1	1	1	1	
11	2S2-22128-70	COVER, THRUST 1	1	1	1	1	
12	90105-06104	BOLT, FLANGE	2	2	2	2	
13	95702-06500	NUT, FLANGE	2	2	2	2	
14	90105-06105	BOLT, FLANGE	1	1	1	1	
15	33D-22141-00	SHAFT, PIVOT	1	1	1	1	
16	90185-16002	NUT, SELF-LOCKING	1	1	1	1	
17	90201-16018	WASHER, PLATE	1	1	1	1	
18	17D-2217A-00	ARM, RELAY	1	1	1	1	
19	93315-32166	BEARING	4	4	4	4	
20	93109-25001	OIL SEAL	4	4	4	4	
21	90387-16026	COLLAR	2	2	2	2	
22	90209-16011	WASHER	4	4	4	4	
23	90201-21014	WASHER, PLATE	4	4	4	4	
24	33D-2217F-00	ROD, CONNECTING 1	1	1	1	1	
25	93315-32166	BEARING	2	2	2	2	
26	93109-21001	OIL SEAL	2	2	2	2	
27	90387-14016	COLLAR	1	1	1	1	



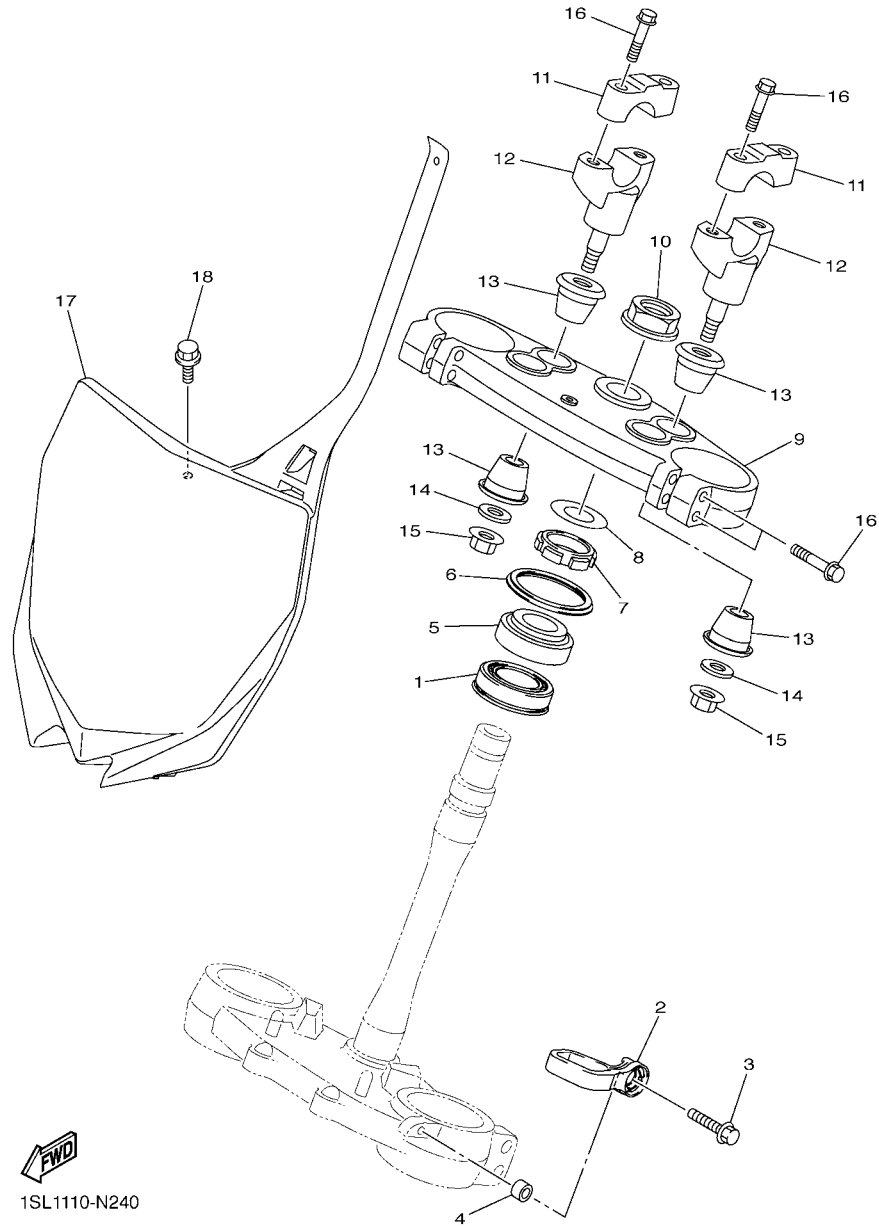


1SL1100-N230

FIG. 23 REAR SUSPENSION

REF. NO.	PART NO.	DESCRIPTION	1SM5	1SM6	1SM7	1SM8	REMARKS
1	1SM-22200-60	SHOCK ABSORBER ASSY, REAR	1				UR FOR DPBSE
	1SM-22200-70	SHOCK ABSORBER ASSY, REAR	1				UR FOR PWS1
	1SM-22200-20	SHOCK ABSORBER ASSY, REAR		1	1		UR FOR DPBSE
	1SM-22200-30	SHOCK ABSORBER ASSY, REAR				1	UR FOR PWS1
	1SM-22200-40	SHOCK ABSORBER ASSY, REAR			1		
2	1SM-22201-30	.DAMPER SUB ASSY	1				
	1SM-22201-10	.DAMPER SUB ASSY		1	1		
	1SM-22201-20	.DAMPER SUB ASSY			1		
3	509-23184-L0	..CAP, AIR VALVE	1	1	1	1	
4	4JX-22226-00	..BUSH, SHOCK ABSORBER LOWER	1	1	1	1	
5	5DH-23183-00	..CIRCLIP	1	1	1	1	
6	33D-22234-00	..GUIDE, SPRING 3	1	1	1	1	
7	1SL-22213-00	..SEAT, SPRING UPPER	1	1	1	1	
8	4AA-22259-70	..LABEL, WARNING	1				
	4AA-22259-40	..LABEL, WARNING		1		1	
	4AA-22259-50	..LABEL, WARNING				1	
9	1SL-22212-20	.SPRING (K=56 BLUE)	1				UR FOR DPBSE
	1SL-22212-30	.SPRING (K=56 RED)	1				UR FOR PWS1
	1SL-22212-60	.SPRING (K=54 BLUE)		1	1	1	UR FOR DPBSE
	1SL-22212-70	.SPRING (K=54 RED)				1	UR FOR PWS1
10	33D-22214-00	..GUIDE, SPRING 1	1	1	1	1	
11	33D-22224-00	..GUIDE, SPRING 2	1	1	1	1	
12	1C3-22253-50	..COLLAR, DISTANCE	2	2	2	2	
13	3JE-22475-00	..SEAL, DUST	2	2	2	2	
14	4EW-22474-00	..SEAL, RING	2	2	2	2	
15	5UN-22176-00	..BEARING	1	1	1	1	
16	5MV-22184-00	..BUSH	1	1	1	1	



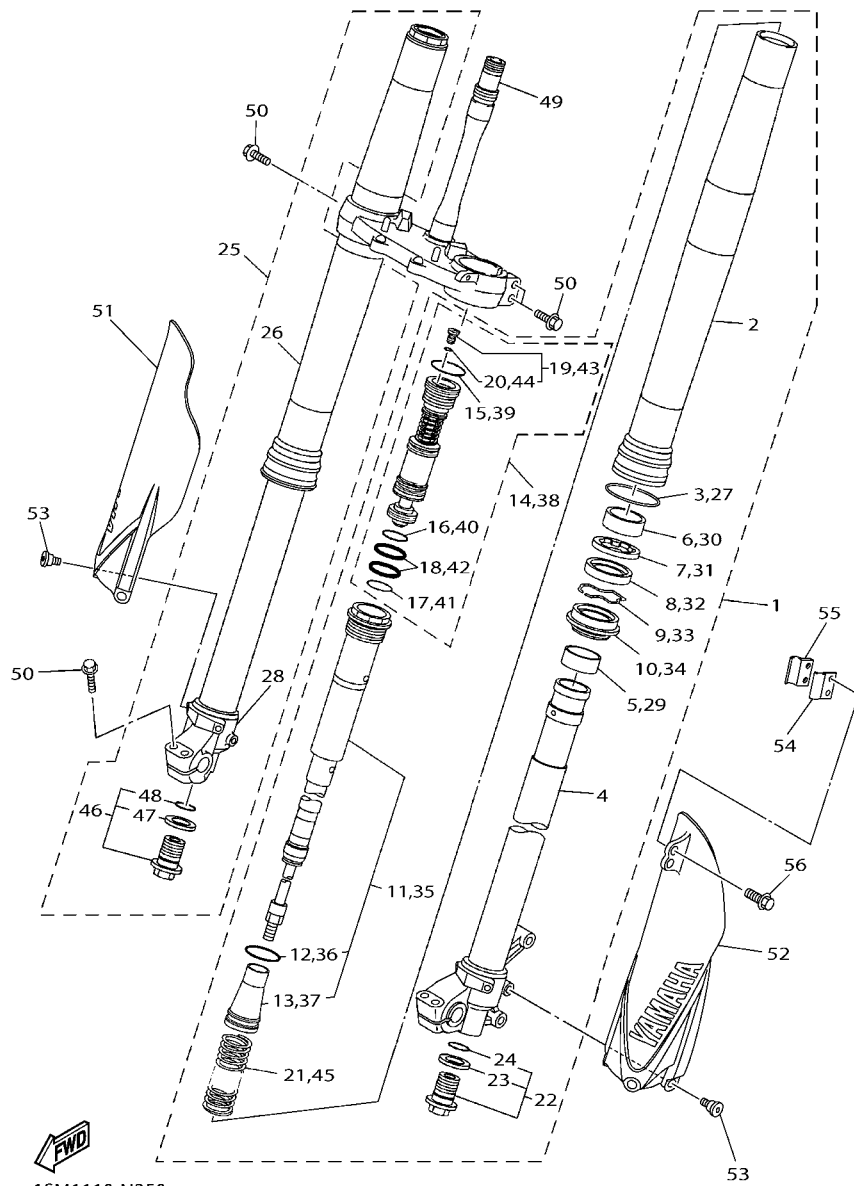


1SL1110-N240

FIG. 24 STEERING

REF. NO.	PART NO.	DESCRIPTION	ISM5	ISM6	ISM7	ISM8	REMARKS
1	93332-00081	BEARING	1	1	1	1	
2	17D-23389-50	GUIDE, CABLE	1	1	1	1	
3	90105-06170	BOLT, FLANGE	1	1	1	1	
4	90387-06105	COLLAR	1	1	1	1	
5	93332-00068	BEARING	1	1	1	1	
6	17D-23416-50	COVER, BALL RACE 2	1	1	1	1	
7	90179-28015	NUT	1	1	1	1	
8	90201-286K9	WASHER, PLATE (T1.0)	1	1	1	1	
9	1SL-23435-00	CROWN, HANDLE	1	1	1	1	
10	90179-24004	NUT	1	1	1	1	
11	18P-23441-00	HOLDER, HANDLE UPPER	2	2	2	2	
12	1SL-23442-00	HOLDER, HANDLE LOWER	2	2	2	2	
13	1SL-23434-00	HOLDER, DAMPER	4	4	4	4	
14	90201-10035	WASHER, PLATE	2	2	2	2	
15	95602-10200	NUT, U FLANGE	2	2	2	2	
16	90105-08154	BOLT, FLANGE	8	8	8	8	
17	17D-23485-50	PLATE, NUMBER	1	1	1	1	
18	90105-06064	BOLT, FLANGE	1	1	1	1	





1SM1110-N250

FIG. 25 FRONT FORK

REF. NO.	PART NO.	DESCRIPTION	1SM5	1SM6	1SM7	1SM8	REMARKS
1	1SM-23102-20	FRONT FORK ASSY (L.H)	1				
	1SM-23102-10	FRONT FORK ASSY (L.H)		1	1	1	
2	33D-23136-00	.TUBE, OUTER	1	1	1	1	
3	17D-23153-00	.RING, SNAP	1	1	1	1	
4	1SL-23120-00	.INNER TUBE COMP. (L.H.)	1	1	1	1	
5	5XE-23171-L0	.PISTON, FRONT FORK	1	1	1	1	
6	5XE-23125-L0	.METAL, SLIDE 1	1	1	1	1	
7	5XC-23146-10	.WASHER, OIL SEAL	1	1	1	1	
8	17D-23145-00	.OIL SEAL	1	1	1	1	
9	5XE-23153-L0	.RING, SNAP	1	1	1	1	
10	5XE-23144-L0	.SEAL, DUST	1	1	1	1	
11	1SM-23170-20	.CYLINDER COMP., FRONT FORK	1				
	1SM-23170-10	.CYLINDER COMP., FRONT FORK		1	1	1	
12	1C3-23147-L0	..O-RING	1	1	1	1	
13	17D-23142-00	..SEAT, SPRING UPPER	1	1	1	1	
14	1SM-2316A-20	.VALVE COMP.	1				
	1SM-2316A-10	.VALVE COMP.		1	1	1	
15	1C3-23188-L0	..O-RING	1	1	1	1	
16	1C3-23188-N0	..O-RING	1	1	1	1	
17	1C3-23188-P0	..O-RING	1	1	1	1	
18	1AE-23147-00	..O-RING	2	2	2	2	
19	1C3-23190-L0	..AIR VALVE COMP.	1	1	1	1	
20	1C3-23188-R0	..O-RING	1	1	1	1	
21	1SL-23141-10	.SPRING, FRONT FORK	1				
	1SM-23141-00	.SPRING, FRONT FORK		1	1	1	
22	5XC-23111-00	.BOLT, CAP	1	1	1	1	
23	2HH-23158-L0	..GASKET	1	1	1	1	

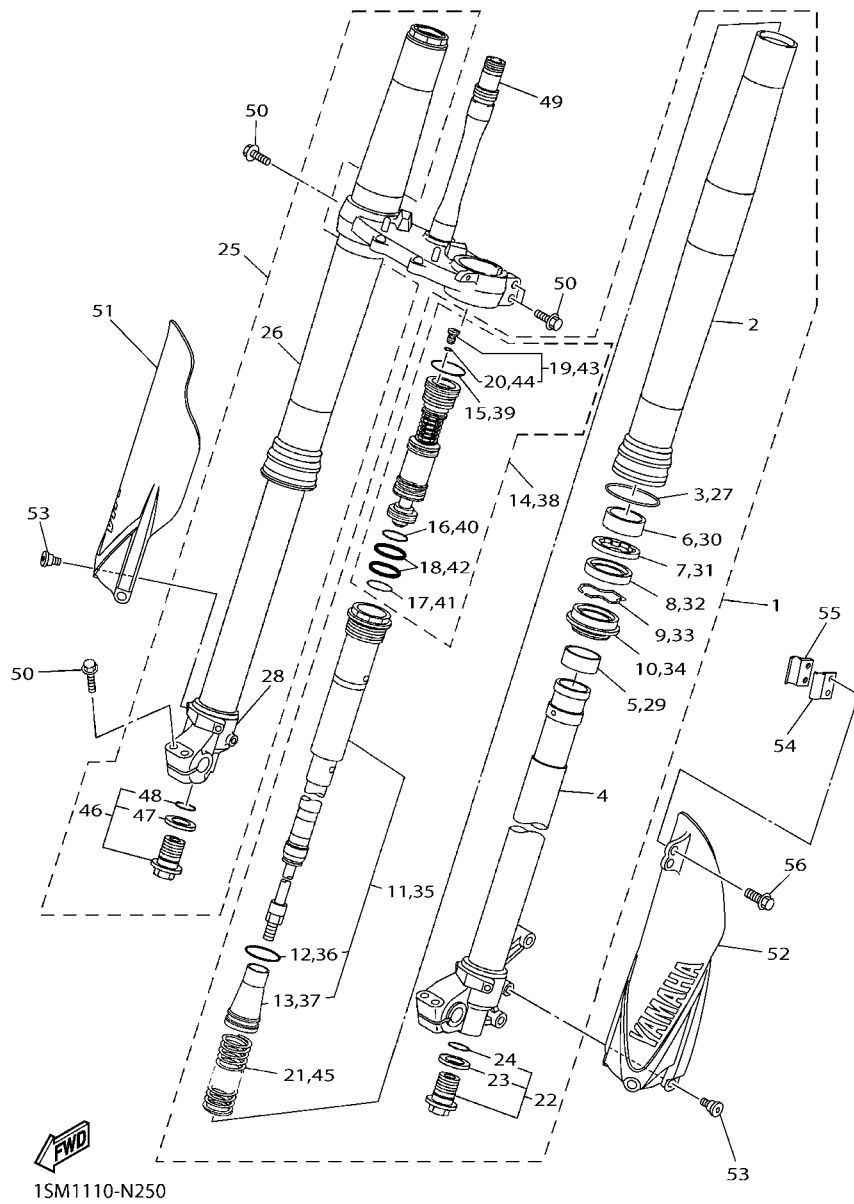


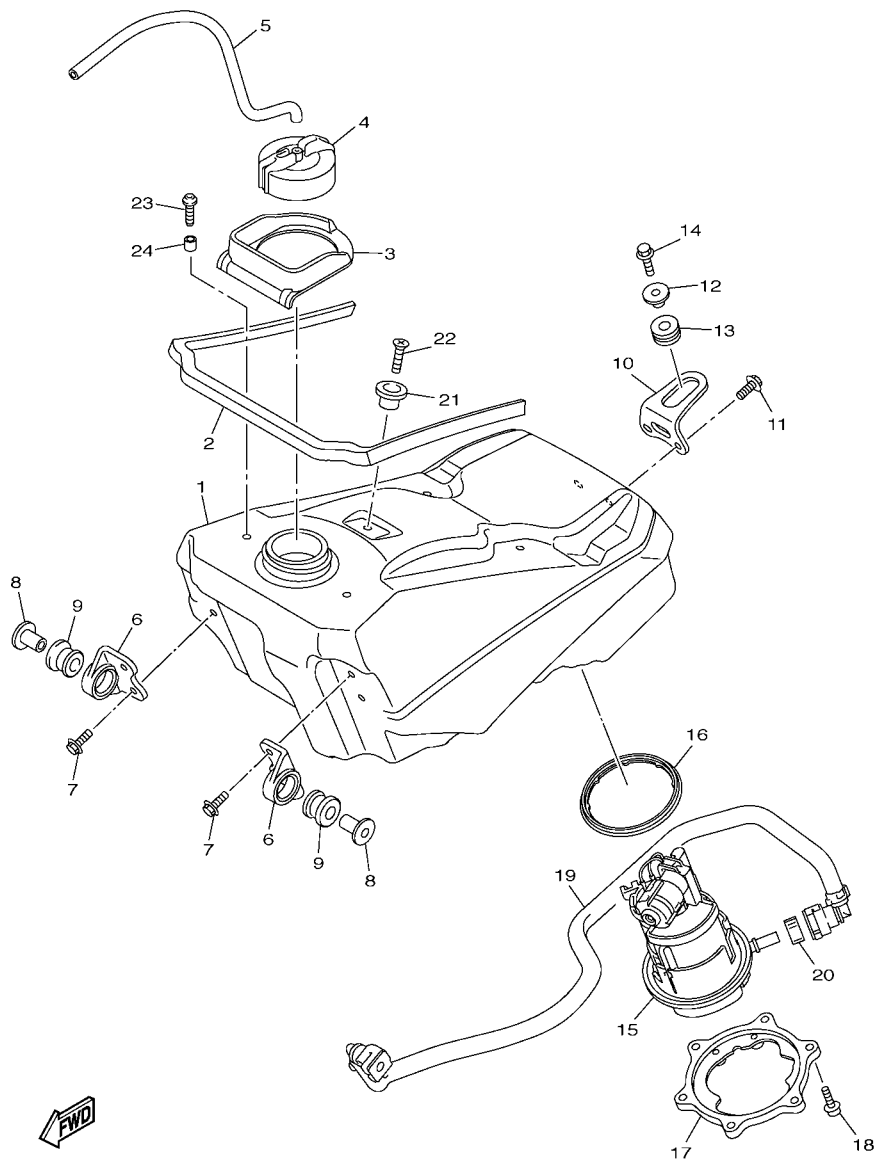
FIG. 25 FRONT FORK

REF. NO.	PART NO.	DESCRIPTION	1SM5	1SM6	1SM7	1SM8	REMARKS
24	276-23114-00	..GASKET	1	1	1	1	
25	1SM-23103-20	FRONT FORK ASSY (R.H)	1				
	1SM-23103-10	FRONT FORK ASSY (R.H)		1	1	1	
26	33D-23136-00	.TUBE, OUTER	1	1	1	1	
27	17D-23153-00	.RING, SNAP	1	1	1	1	
28	1SL-23110-00	..INNER TUBE COMP. (R.H.)	1	1	1	1	
29	5XE-23171-L0	.PISTON, FRONT FORK	1	1	1	1	
30	5XE-23125-L0	.METAL, SLIDE 1	1	1	1	1	
31	5XC-23146-10	.WASHER, OIL SEAL	1	1	1	1	
32	17D-23145-00	.OIL SEAL	1	1	1	1	
33	5XE-23153-L0	.RING, SNAP	1	1	1	1	
34	5XE-23144-L0	.SEAL, DUST	1	1	1	1	
35	1SM-23170-20	.CYLINDER COMP., FRONT FORK	1				
	1SM-23170-10	.CYLINDER COMP., FRONT FORK		1	1	1	
36	1C3-23147-L0	..O-RING	1	1	1	1	
37	17D-23142-00	..SEAT, SPRING UPPER	1	1	1	1	
38	1SM-2316A-20	.VALVE COMP.	1				
	1SM-2316A-10	.VALVE COMP.		1	1	1	
39	1C3-23188-L0	..O-RING	1	1	1	1	
40	1C3-23188-N0	..O-RING	1	1	1	1	
41	1C3-23188-P0	..O-RING	1	1	1	1	
42	1AE-23147-00	..O-RING	2	2	2	2	
43	1C3-23190-L0	..AIR VALVE COMP.	1	1	1	1	
44	1C3-23188-R0	..O-RING	1	1	1	1	
45	1SL-23141-10	.SPRING, FRONT FORK	1				
	1SM-23141-00	.SPRING, FRONT FORK		1	1	1	
46	5XC-23111-00	.BOLT, CAP	1	1	1	1	



FIG. 26 FUEL TANK

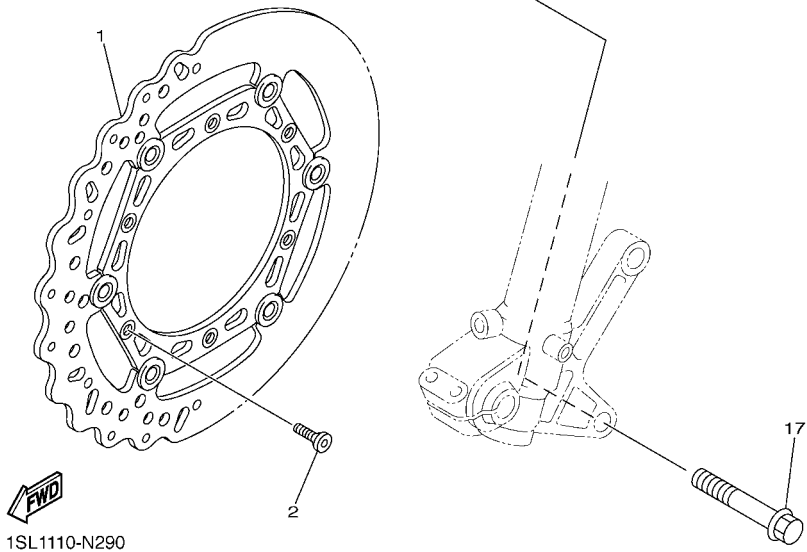
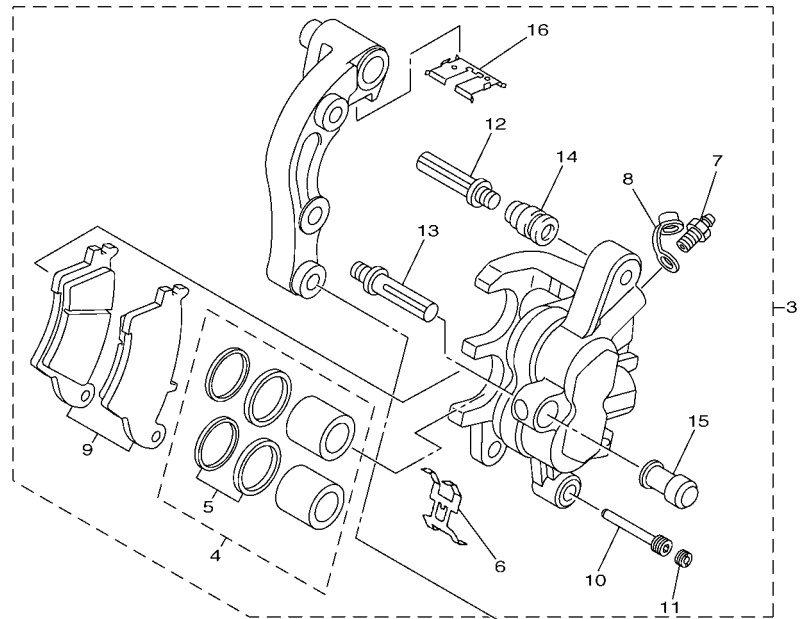
REF. NO.	PART NO.	DESCRIPTION	1SM5	1SM6	1SM7	1SM8	REMARKS
1	1SL-24110-00	FUEL TANK COMP.	1	1	1	1	
2	1S4-2414J-00	DAMPER, PLATE 2	3	3	3	3	
3	1SL-24188-00	MOLD, FUEL TANK	1	1	1	1	
4	1SL-24610-00	CAP ASSY	1	1	1	1	
5	90445-09008	HOSE (L470)	1	1	1	1	
6	1SL-24115-00	STAY, FUEL TANK 1	2	2	2	2	
7	90105-06170	BOLT, FLANGE	4	4	4	4	
8	90387-06091	COLLAR	2	2	2	2	
9	90480-18549	GROMMET	2	2	2	2	
10	1SL-2419A-00	HOLDER	1	1	1	1	
11	90105-06170	BOLT, FLANGE	2	2	2	2	
12	90387-066Y6	COLLAR	1	1	1	1	
13	90480-10289	GROMMET	1	1	1	1	
14	95022-06020	BOLT, FLANGE	1	1	1	1	
15	33D-13907-00	FUEL PUMP COMP.	1	1	1	1	
16	33D-24486-00	O-RING	1	1	1	1	
17	33D-24491-00	BRACKET, FUEL PUMP	1	1	1	1	
18	90110-05058	BOLT, HEXAGON SOCKET HEAD	6	6	6	6	
19	1SM-13971-00	PIPE, FUEL 1	1	1	1	1	
20	33D-24135-00	CLAMP 1	1	1	1	1	
21	4EW-2412F-00	BRACKET, SEAT	1	1	1	1	
22	98707-06025	SCREW, FLAT HEAD	1	1	1	1	
23	90111-06149	BOLT, HEX. SOCKET BUTTON	2	2	2	2	
24	90387-06284	COLLAR	2	2	2	2	



1SL1110-N260







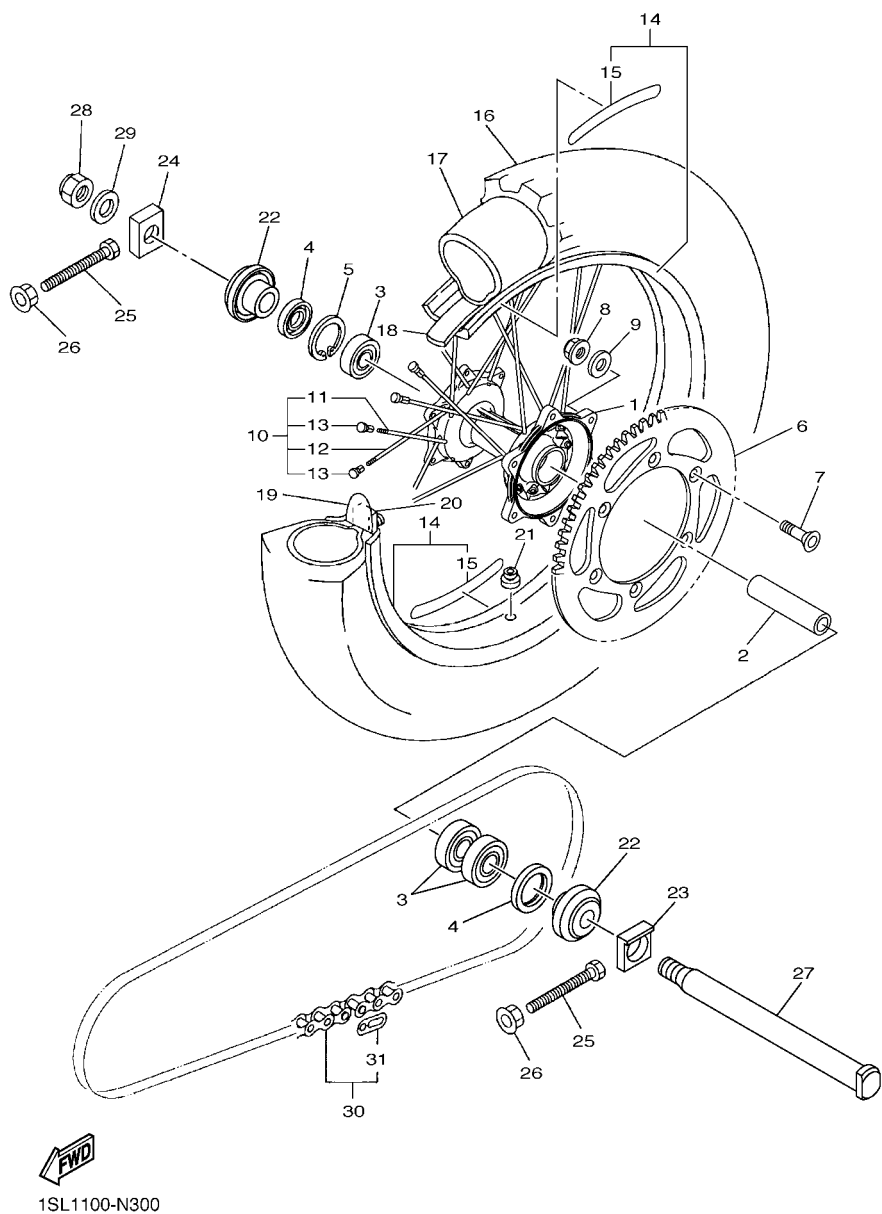
1SL1110-N290

FIG. 29 FRONT BRAKE CALIPER

REF. NO.	PART NO.	DESCRIPTION	ISM5	ISM6	ISM7	ISM8	REMARKS
1	5XC-2581T-G0	DISK BRAKE ASSY	1	1	1	1	
2	90151-06051	SCREW, COUNTERSUNK	6	6	6	6	
3	5XC-2580T-G0	CALIPER ASSY (LEFT)	1	1	1	1	
4	5XC-W0057-00	.PISTON ASSY, CALIPER	1	1	1	1	
5	5KM-W0047-10	..CALIPER SEAL KIT	1	1	1	1	
6	5DH-25919-00	..SUPPORT, PAD	1	1	1	1	
7	1UY-25824-51	.SCREW, BLEED	1	1	1	1	
8	1UY-25825-51	.CAP	1	1	1	1	
9	5XC-W0045-00	.BRAKE PAD KIT	1	1	1	1	
10	5DH-25933-00	.PIN, PAD	1	1	1	1	
11	5DH-25916-00	.PLUG	1	1	1	1	
12	3SP-25926-51	.BOLT	1	1	1	1	
13	3SP-25914-51	.PIN, SLIDE	1	1	1	1	
14	3JD-25917-00	.BOOT, CALIPER	1	1	1	1	
15	1UY-25937-51	.BOOT 2	1	1	1	1	
16	5XC-25849-G0	.RETAINER, CALIPER	1	1	1	1	
17	90105-08137	BOLT, FLANGE	2	2	2	2	

FIG. 30 REAR WHEEL

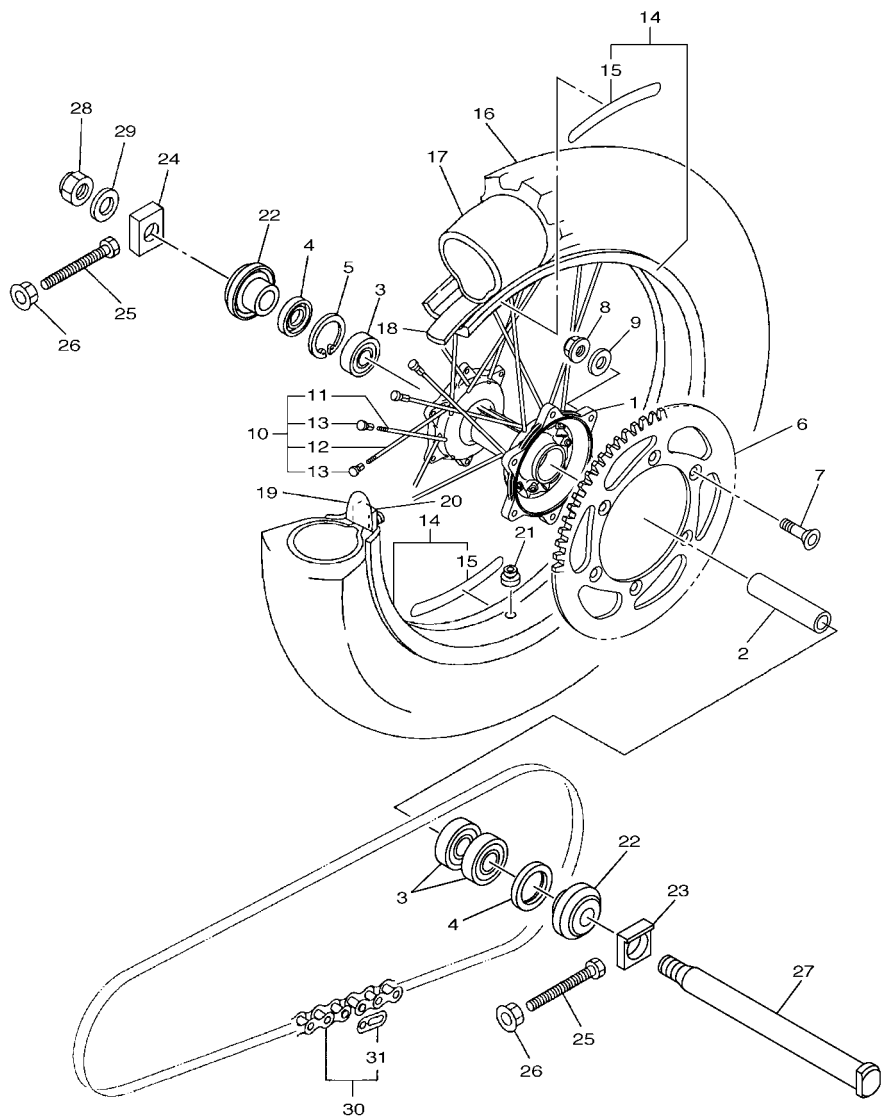
REF. NO.	PART NO.	DESCRIPTION	ISM5	ISM6	ISM7	ISM8	REMARKS
1	17D-25311-00	HUB, REAR	1	1	1	1	
2	17D-25317-00	SPACER, BEARING	1	1	1	1	
3	93306-90510	BEARING	3	3	3	3	
4	93102-32337	OIL SEAL	2	2	2	2	
5	99009-42700	CIRCLIP	1	1	1	1	
6	17D-25450-50	SPROCKET, DRIVEN (50T)	1	1	1	1	STD
	17D-25447-50	SPROCKET, DRIVEN (47T)	1	1	1	1	AP
	17D-25448-50	SPROCKET, DRIVEN (48T)	1	1	1	1	AP
	17D-25449-50	SPROCKET, DRIVEN (49T)	1	1	1	1	AP
	17D-25451-50	SPROCKET, DRIVEN (51T)	1	1	1	1	AP
	17D-25452-50	SPROCKET, DRIVEN (52T)	1	1	1	1	AP
7	90109-08078	BOLT	6	6	6	6	
8	90185-08008	NUT, SELF-LOCKING	6	6	6	6	
9	90201-08048	WASHER, PLATE	6	6	6	6	
10	34P-25304-00	SPOKE SET, REAR	1	1	1	1	
11	34P-25396-00	.SPOKE, INNER 2			18		
12	34P-25397-00	.SPOKE, OUTER 2			18		
13	5ET-25395-00	.NIPPLE, SPOKE			36		
14	94418-19036	RIM (1.85-19)	1	1	1	1	
15	17D-2531B-00	.EMBLEM, WHEEL	2	2	2	2	
16	94110-19019	TIRE (100/90-19 57M M404)	1			1	BRIDGESTONE
	*	TIRE (100/90-19 57M NHS)		1			LM PIRELLI
	*	TIRE (100/90-19 57M MX52)			1		LM DUNLOP
17	94210-19222	TUBE (100/90-19 M/C TR4)	1			1	BRIDGESTONE
	*	TUBE (110/90-19)		1			LM PIRELLI
	*	TUBE (100/90-19 M/C TR4 BTL)			1		LM DUNLOP
18	94316-19156	BAND, RIM (1.85-19)	1			1	BRIDGESTONE



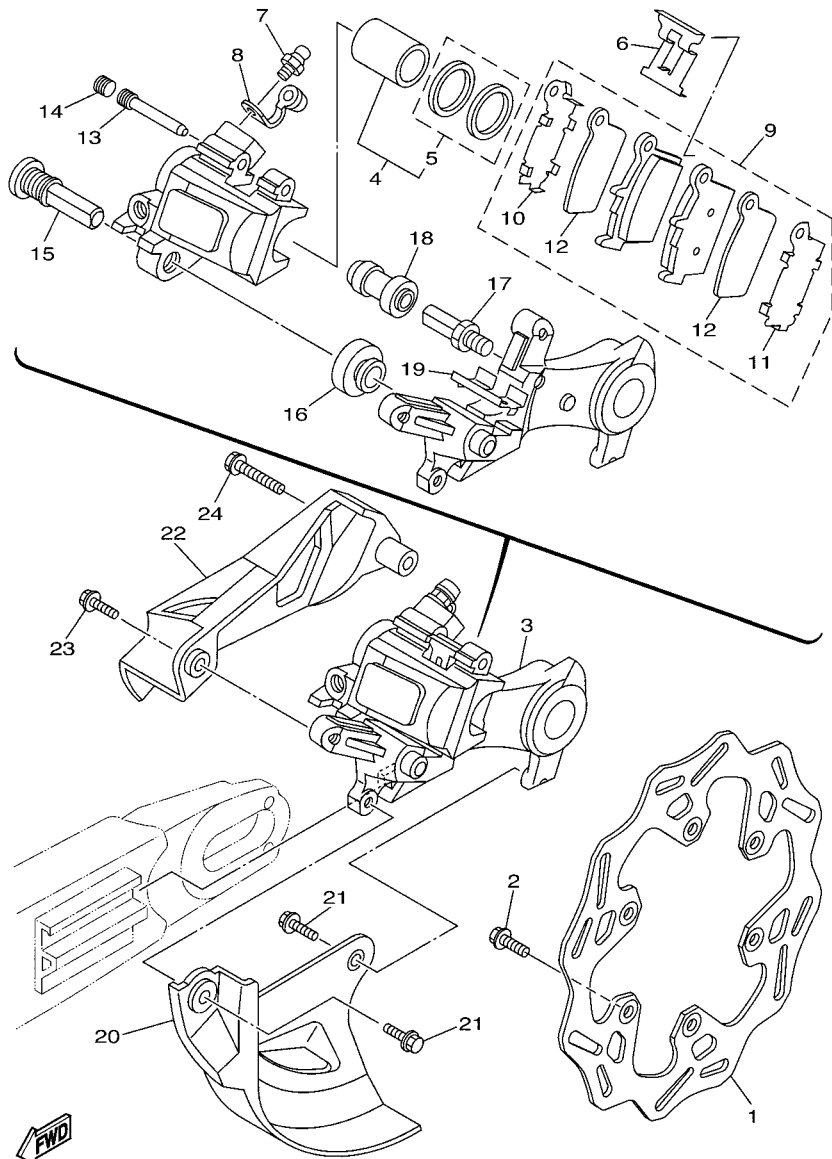


**FIG. 30 REAR WHEEL**

REF. NO.	PART NO.	DESCRIPTION	ISM5	ISM6	ISM7	ISM8	REMARKS
18	*	BAND, RIM (3.50-18)		1			LM METZELER
	*	BAND, RIM (22-19)			1		LM DUNLOP
19	4XM-25394-00	SPACER, BEAD	1	1	1	1	
20	4XM-25364-00	DAMPER	1	1	1	1	
21	90480-08608	GROMMET	1	1	1	1	
22	17D-2530S-00	COLLAR ASSY	2	2	2	2	
23	1SL-25388-00	PULLER, CHAIN 1	1	1	1	1	
24	1SL-25389-00	PULLER, CHAIN 2	1	1	1	1	
25	90101-08006	BOLT	2	2	2	2	
26	90179-08019	NUT	2	2	2	2	
27	17D-25381-00	AXLE, WHEEL	1	1	1	1	
28	90185-22011	NUT, SELF-LOCKING	1	1	1	1	
29	90201-22023	WASHER, PLATE	1	1	1	1	
30	9Y582-28113	CHAIN (DID520DMA2-114LL)	1			1	
	9Y582-28113	CHAIN (DID520DMA2-114LL)		1	1		
31	94682-28001	.JOINT, CHAIN(DID520DM G&B-RJ)	1			1	
	94682-28001	.JOINT, CHAIN(DID520DM G&B-RJ)		1	1		



1SL1100-N300



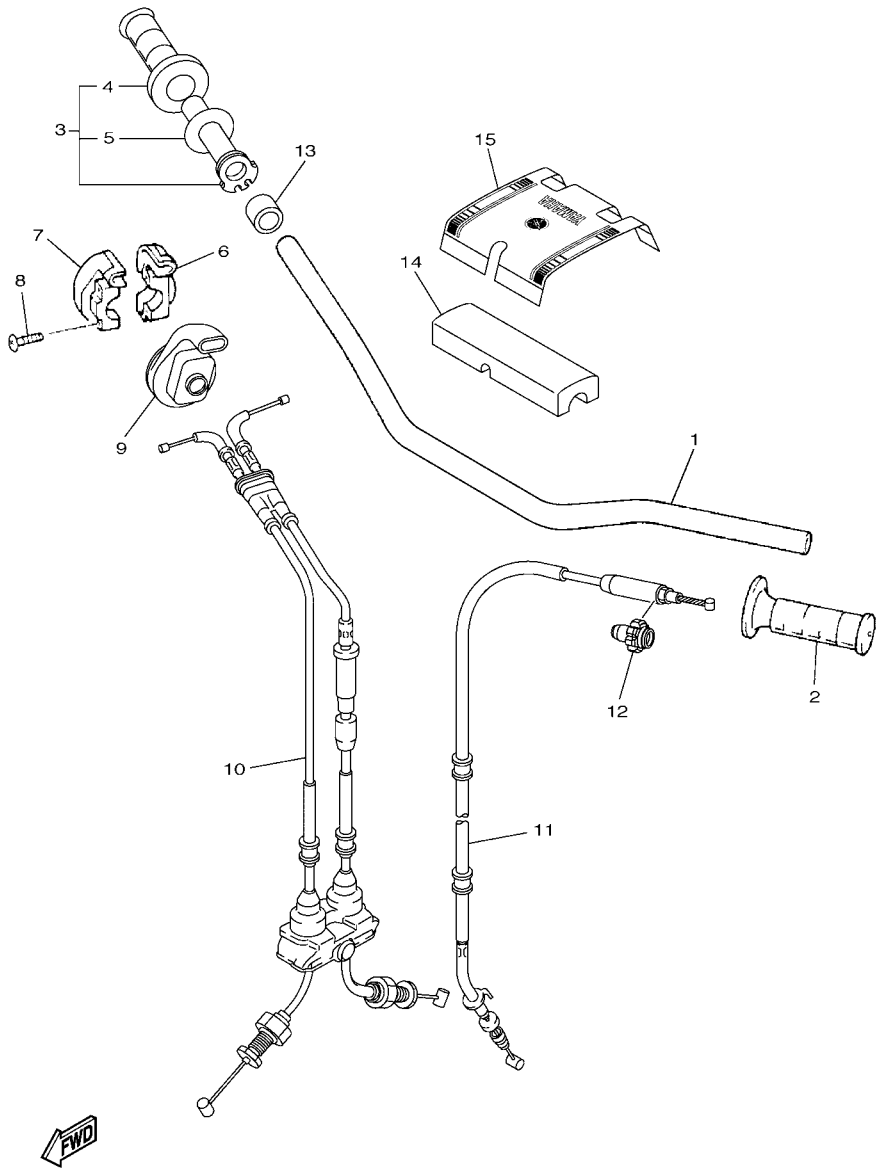
33DD110-M310

FIG. 31 REAR BRAKE CALIPER

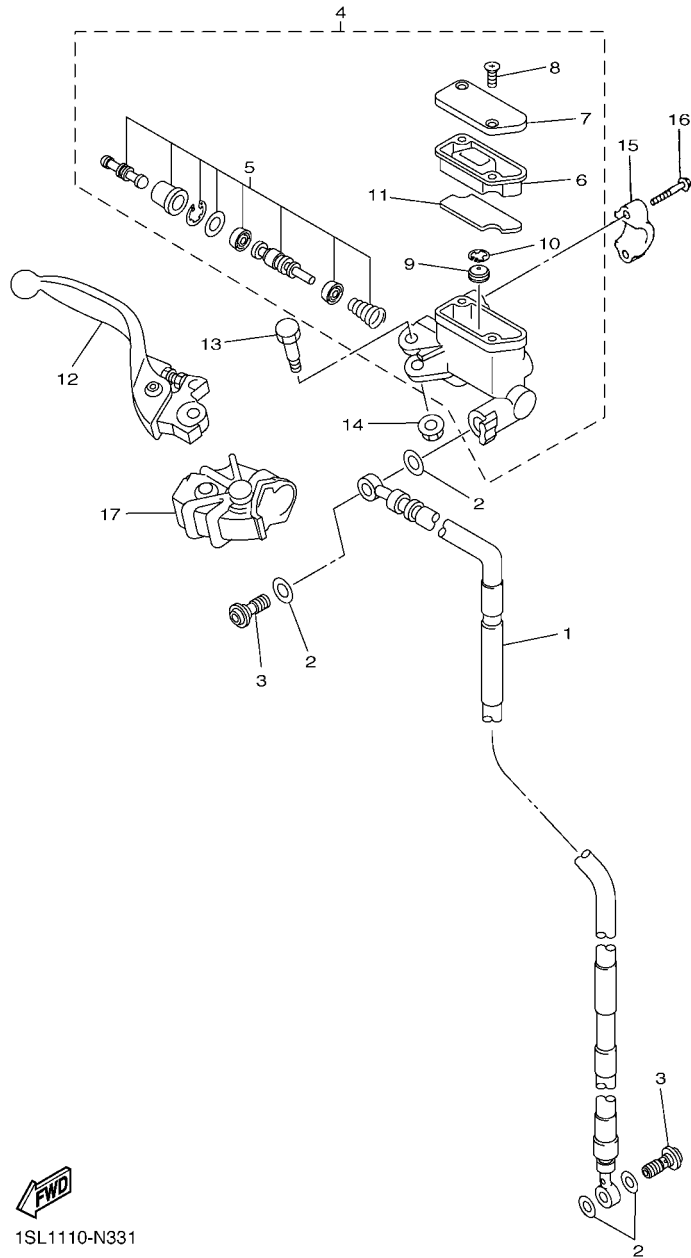
REF. NO.	PART NO.	DESCRIPTION	ISM5	ISM6	ISM7	ISM8	REMARKS
1	2S2-2582W-70	DISK, REAR BRAKE 2	1	1	1	1	
2	90105-06156	BOLT, FLANGE	6	6	6	6	
3	17D-2580W-01	CALIPER ASSY, REAR 2	1		1	1	
	17D-2580W-11	CALIPER ASSY, REAR 2		1			
4	5UN-W0057-50	.PISTON ASSY, CALIPER	1	1	1	1	
5	5UN-W0047-50	..CALIPER SEAL KIT	1	1	1	1	
6	5DH-25919-50	.SUPPORT, PAD	1	1	1	1	
7	1UY-25824-51	.SCREW, BLEED	1	1	1	1	
8	1UY-25825-51	.CAP	1	1	1	1	
9	1C3-W0046-50	.BRAKE PAD KIT 2	1		1	1	
	1C3-W0046-B0	.BRAKE PAD KIT 2		1			
10	5UN-25828-60	..SHIM, CALIPER	1	1	1	1	
11	5UN-25827-60	..SHIM, CALIPER	1	1	1	1	
12	5UN-22898-60	..INSULATOR, HEAT	2	2	2	2	
13	8CR-25924-00	.PIN, PAD	1	1	1	1	
14	5DH-25916-00	.PLUG	1	1	1	1	
15	5DH-25914-50	.PIN, SLIDE	1	1	1	1	
16	3JD-25917-00	.BOOT, CALIPER	1	1	1	1	
17	5UN-25914-00	.PIN, SLIDE	1	1	1	1	
18	1UY-25937-51	.BOOT 2	1	1	1	1	
19	5UN-25913-00	.RETAINER	1	1	1	1	
20	17D-25718-50	PROTECTOR, DISK BRAKE	1	1	1	1	
21	90105-06110	BOLT, FLANGE	2	2	2	2	
22	17D-27491-50	PROTECTOR	1	1	1	1	
23	90105-06110	BOLT, FLANGE	1	1	1	1	
24	90105-06111	BOLT, FLANGE	1	1	1	1	

**FIG. 32 STEERING HANDLE & CABLE**

REF. NO.	PART NO.	DESCRIPTION	ISM5	ISM6	ISM7	ISM8	REMARKS
1	17D-26111-H0	HANDLEBAR	1	1	1	1	
2	4GY-26241-00	GRIP	1	1	1	1	
3	1SL-26240-00	GRIP ASSY	1	1	1	1	
4	4GY-26242-00	.GRIP (RIGHT)	1	1	1	1	
5	3Y1-26249-00	.RING, LEAF	1	1	1	1	
6	5BE-26281-01	CAP, GRIP UPPER	1	1	1	1	
7	5BE-26282-00	CAP, GRIP UNDER	1	1	1	1	
8	98507-05020	SCREW, PAN HEAD	2	2	2	2	
9	5SF-26287-11	COVER, CAP GRIP	1	1	1	1	
10	1SM-26302-00	THROTTLE CABLE ASSY	1	1	1	1	
11	1SM-26335-00	CABLE, CLUTCH	1	1	1	1	
12	34P-26342-00	BOOT, CABLE	1	1	1	1	
13	90387-225N2	COLLAR	1	1	1	1	
14	17D-26124-00	PROTECTOR, HANDLEBAR	1	1	1	1	
15	17D-26143-H0	COVER, HANDLE UPPER 1	1	1	1	1	



1SL1110-N320

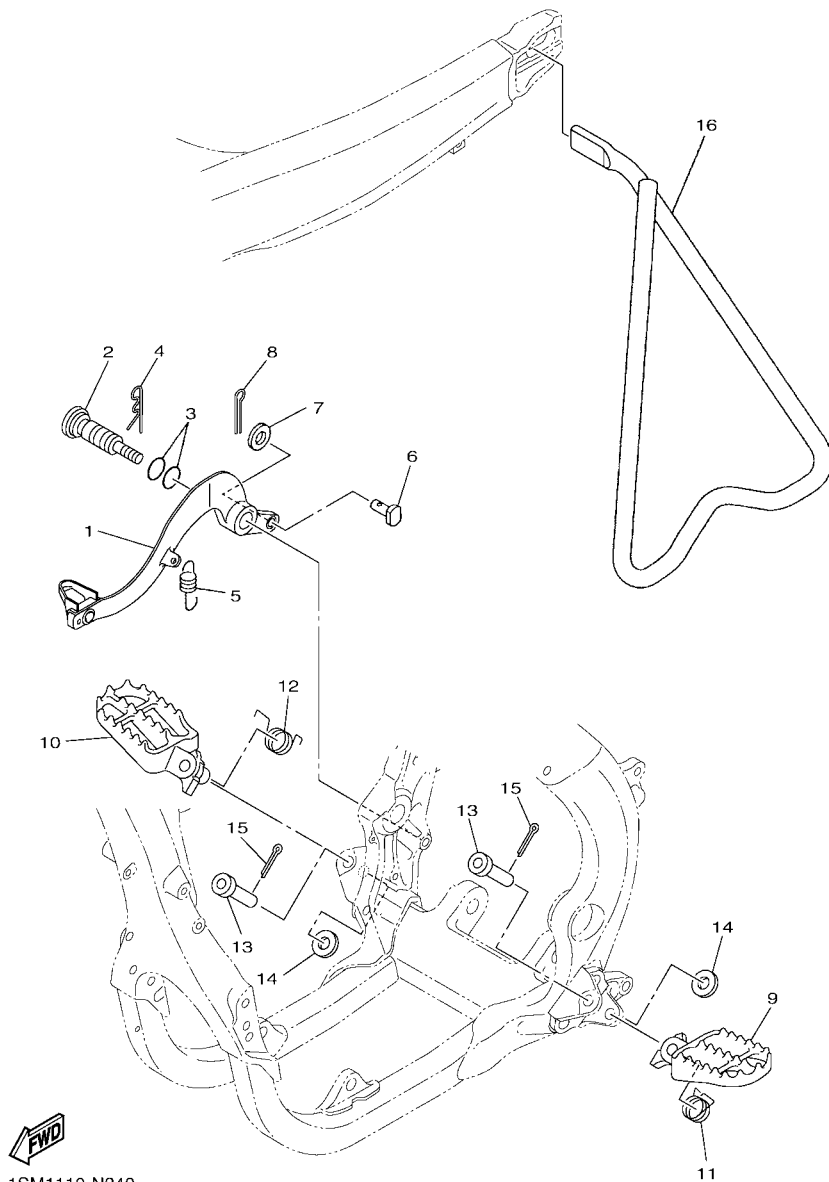


1SL1110-N331

FIG. 33 FRONT MASTER CYLINDER

REF. NO.	PART NO.	DESCRIPTION	ISM5	ISM6	ISM7	ISM8	REMARKS
1	1SL-25872-00	HOSE, BRAKE 1	1	1	1	1	
2	90430-10005	GASKET	4	4	4	4	
3	90401-10172	BOLT, UNION	2	2	2	2	
4	5XC-W2587-00	MASTER CYLINDER SUB ASSY	1	1	1	1	
5	5XC-W0041-00	.CYLINDER KIT, MASTER	1	1	1	1	
6	5XC-25854-G0	.DIAPHRAGM, RESERVOIR	1	1	1	1	
7	5XC-25852-G0	.CAP, RESERVOIR	1	1	1	1	
8	98706-04012	.SCREW, FLAT HEAD	2	2	2	2	
9	5CG-25715-00	.SEPARATOR ASSY	1	1	1	1	
10	5CG-2585G-00	.CIRCLIP	1	1	1	1	
11	5XC-25853-G0	.FLOAT, RESERVOIR	1	1	1	1	
12	5XC-83922-L0	LEVER 2	1	1	1	1	
13	5MV-2589F-00	BOLT, LEVER	1	1	1	1	
14	95701-06500	NUT, WITH WASHER	1	1	1	1	
15	5MV-25867-00	BRACKET, MASTER CYLINDER	1	1	1	1	
16	5MV-25833-00	BOLT, FITTING	2	2	2	2	
17	5XC-26372-G0	COVER, HANDLE LEVER 1	1	1	1	1	

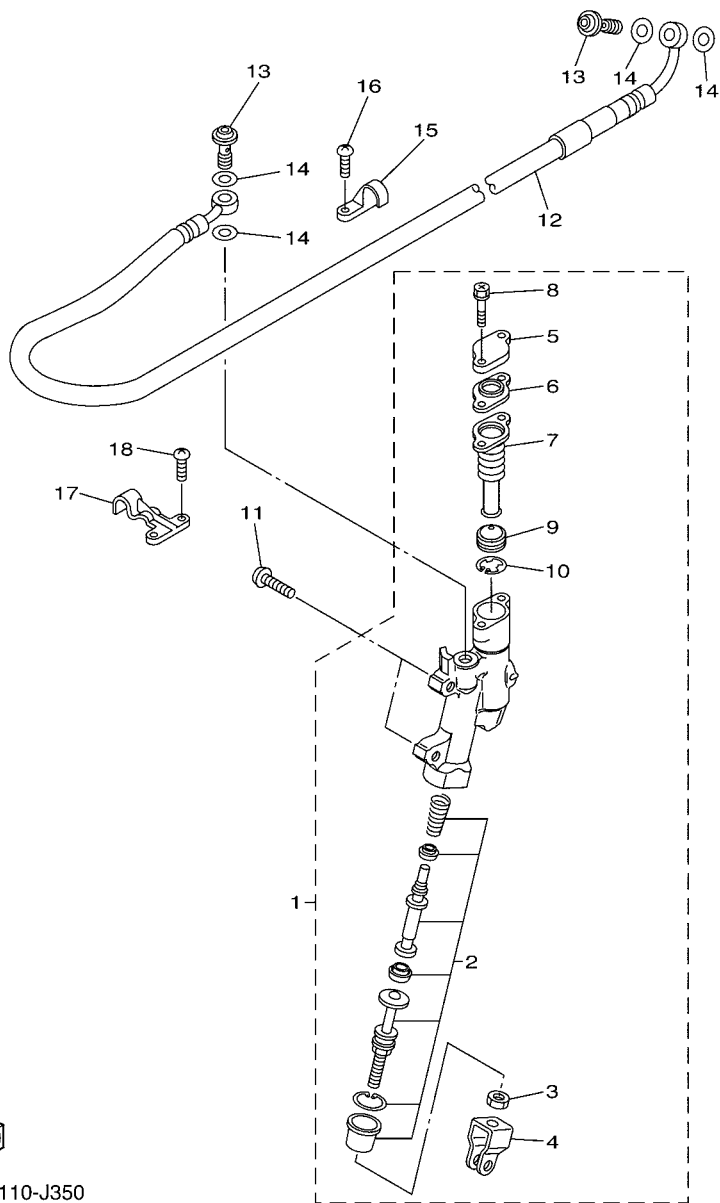
**FIG. 34 STAND & FOOTREST**



1SM1110-N340

REF. NO.	PART NO.	DESCRIPTION	1SM5	1SM6	1SM7	1SM8	REMARKS
1	17D-27200-51	PEDAL, BRAKE	1	1	1	1	
2	17D-27217-00	BOLT	1	1	1	1	
3	93210-11073	O-RING	2	2	2	2	
4	90468-16001	CLIP	1	1	1	1	
5	90506-20031	SPRING, TENSION	1	1	1	1	
6	90240-08120	PIN, CLEVIS	1	1	1	1	
7	90201-08044	WASHER, PLATE	1	1	1	1	
8	91402-20012	PIN, COTTER	1	1	1	1	
9	17D-27411-00	FOOTREST 1	1	1	1	1	
10	17D-27421-00	FOOTREST 2	1	1	1	1	
11	90508-28015	SPRING, TORSION	1	1	1	1	
12	90508-28018	SPRING, TORSION	1	1	1	1	
13	90240-10004	PIN, CLEVIS	2	2	2	2	
14	90201-10032	WASHER, PLATE	2	2	2	2	
15	91402-25015	PIN, COTTER	2	2	2	2	
16	34P-27311-00	STAND, SIDE	1	1	1	1	

**FIG. 35 REAR MASTER CYLINDER**



33D1110-J350

REF. NO.	PART NO.	DESCRIPTION	1SM5	1SM6	1SM7	1SM8	REMARKS
1	33D-2583V-00	RR. MASTER CYLINDER ASSY.	1	1	1	1	
2	5UN-W0042-50	.CYLINDER KIT, MASTER	1	1	1	1	
3	5UN-27218-00	.NUT	1	1	1	1	
4	5UN-27222-00	.JOINT	1	1	1	1	
5	5UN-25852-50	.CAP, RESERVOIR	1	1	1	1	
6	5UN-2585B-00	.PLATE, DIAPHRAGM	1	1	1	1	
7	5UN-25854-00	.DIAPHRAGM, RESERVOIR	1	1	1	1	
8	5UN-27217-00	.BOLT	2	2	2	2	
9	5CG-25715-00	.SEPARATOR ASSY	1	1	1	1	
10	5CG-2585G-00	.CIRCLIP	1	1	1	1	
11	90111-06116	BOLT,HEX. SOCKET BUTTON	2	2	2	2	
12	5XC-25873-L0	HOSE, BRAKE 2	1	1	1	1	
13	90401-10172	BOLT, UNION	2	2	2	2	
14	90430-10005	GASKET	4	4	4	4	
15	1C3-25886-50	HOLDER, BRAKE HOSE	1	1	1	1	
16	98502-05010	SCREW, PAN HEAD	2	2	2	2	
17	1C3-25876-50	HOLDER, BRAKE HOSE 2	1	1	1	1	
18	98502-05010	SCREW, PAN HEAD	2	2	2	2	

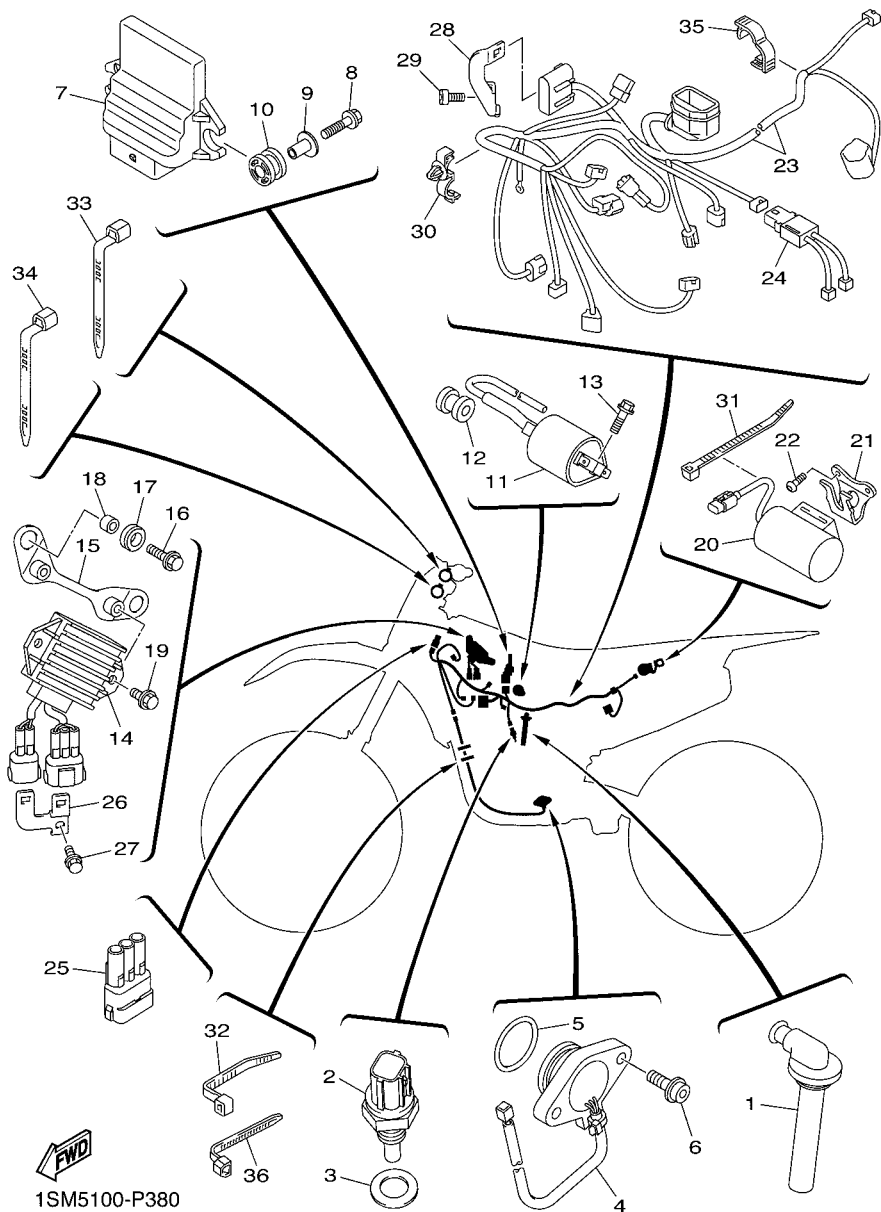




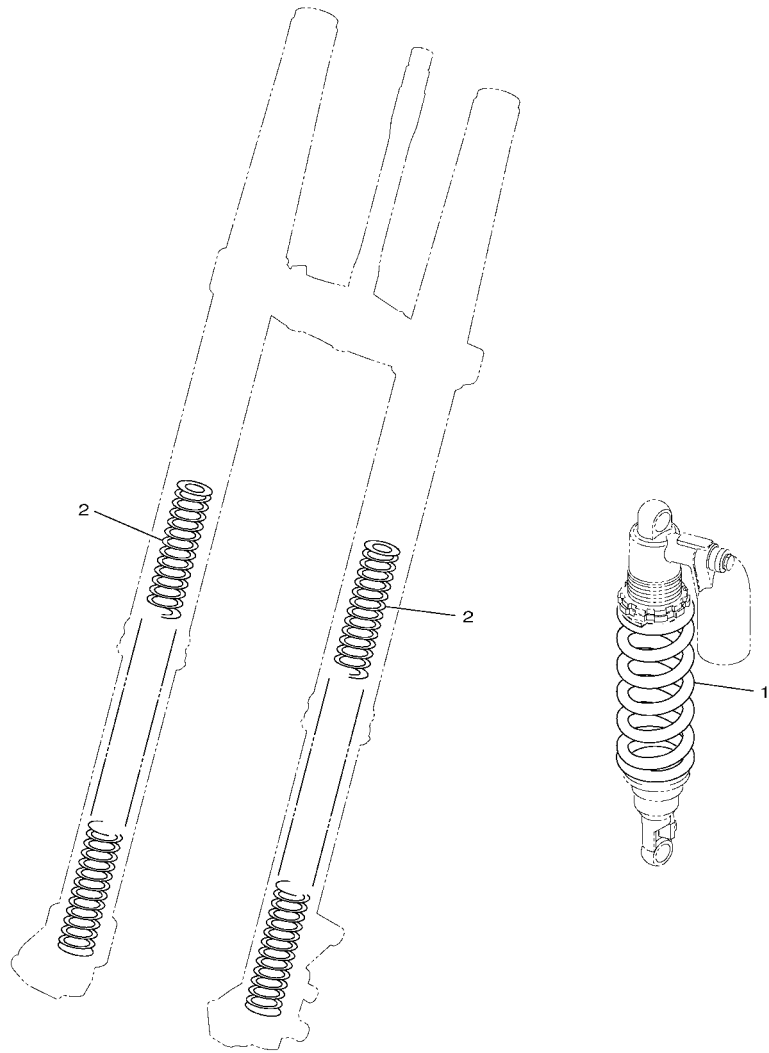


FIG. 38 ELECTRICAL 1

REF. NO.	PART NO.	DESCRIPTION	1SM5	1SM6	1SM7	1SM8	REMARKS
1	33D-82370-00	PLUG CAP ASSY	1	1	1	1	
2	4P9-83591-00	THERMO UNIT	1	1	1	1	
3	90430-10004	GASKET	1	1	1	1	
4	1SL-82540-00	NEUTRAL SWITCH ASSY	1	1	1	1	
5	93210-21001	O-RING	1	1	1	1	
6	90110-05062	BOLT, HEXAGON SOCKET HEAD	2	2	2	2	
7	1SM-8591A-40	ENGINE CONTROL UNIT ASSY	1				
	1SM-8591A-50	ENGINE CONTROL UNIT ASSY		1		1	
	1SM-8591A-60	ENGINE CONTROL UNIT ASSY			1		
8	90105-05005	BOLT, FLANGE	2	2	2	2	
9	90387-05048	COLLAR	2	2	2	2	
10	90480-13029	GROMMET	2	2	2	2	
11	1SM-82310-00	IGNITION COIL ASSY	1	1	1	1	
12	90480-11015	GROMMET	1	1	1	1	
13	95022-06016	BOLT, FLANGE	2	2	2	2	
14	1SL-81960-00	RECTIFIER & REGULATOR ASSY	1	1	1	1	
15	1SL-21287-00	BRACKET, REGULATOR	1	1	1	1	
16	90105-06203	BOLT, FLANGE	2	2	2	2	
17	90480-13025	GROMMET	2	2	2	2	
18	90387-066J9	COLLAR	2	2	2	2	
19	90105-06064	BOLT, FLANGE	2	2	2	2	
20	1SL-81965-00	CONDENSER, SMOOTHING	1	1	1	1	
21	1SL-21273-00	BRKT. CONDENSER	1	1	1	1	
22	92017-05012	BOLT, BUTTON HEAD	2	2	2	2	
23	1SM-82590-00	WIRE HARNESS ASSY	1	1	1	1	
24	1SL-82309-00	WIRE, SUB LEAD	1	1	1	1	
25	33D-82378-00	CONNECTOR	1	1	1	1	







1SL1110-N390

FIG. 39 ALTERNATE FOR CHASSIS

REF. NO.	PART NO.	DESCRIPTION	1SM5	1SM6	1SM7	1SM8	REMARKS
1	1SL-22212-00	SPRING (K=58 BLUE)	1	1	1	1	AP FOR DPBSE
	1SL-22212-10	SPRING (K=58 RED)	1			1	AP FOR PWS1
	1SL-22212-20	SPRING (K=56 BLUE)	1	1	1	1	AP FOR DPBSE
	1SL-22212-30	SPRING (K=56 RED)	1			1	AP FOR PWS1
	1SL-22212-40	SPRING (K=52 BLUE)	1	1	1	1	AP FOR DPBSE
	1SL-22212-50	SPRING (K=52 RED)	1			1	AP FOR PWS1
	1SL-22212-60	SPRING (K=54 BLUE)	1	1	1	1	AP FOR DPBSE
	1SL-22212-70	SPRING (K=54 RED)	1			1	AP FOR PWS1
	1SL-22212-80	SPRING (K=60 BLUE)	1	1	1	1	AP FOR DPBSE
	1SL-22212-90	SPRING (K=60 RED)	1			1	AP FOR PWS1
2	1SL-23141-20	SPRING, FRONT FORK (K=4.5)	1	1	1	1	AP
	1SL-23141-30	SPRING, FRONT FORK (K=4.6)	1	1	1	1	AP
	1SL-23141-40	SPRING, FRONT FORK (K=4.7)	1	1	1	1	AP
	1SL-23141-50	SPRING, FRONT FORK (K=4.8)	1	1	1	1	AP
	1SL-23141-60	SPRING, FRONT FORK (K=4.9)	1	1	1	1	AP
	1SL-23141-70	SPRING, FRONT FORK (K=5.0)	1	1	1	1	AP

NUMERICAL INDEX

PART NO.	REF. NO.	PART NO.	REF. NO.	PART NO.	REF. NO.	PART NO.	REF. NO.	PART NO.	REF. NO.	PART NO.	REF. NO.
1SM-11101-09	1 - 1	3LD-12168-H1	3 - 14	1SM-13597-00	9 - 1	1SM-1477E-10	11 - 24	17D-17231-10	16 - 17	3RV-21668-B0	22 - 33
3D7-11133-10	1 - 3	3LD-12168-K1	3 - 14	1SM-13750-10	10 - 1	1SL-1477G-00	11 - 26	1SM-17241-00	16 - 16	1SL-21710-00	21 - 1
5TA-11134-10	1 - 2	3LD-12168-M1	3 - 14	1SM-13761-00	10 - 11	1SL-1477H-00	11 - 27	1SM-17251-00	16 - 20	1SL-21719-00	21 - 12
1SM-11166-00	1 - 19	3LD-12168-R1	3 - 14	33D-13907-00	26 - 15	1SM-14788-00	11 - 12	1SM-17411-00	16 - 2	1SL-2171E-00	19 - 41
1SM-11181-00	1 - 11	3LD-12168-U1	3 - 14	1SM-13938-00	10 - 2	1SM-15100-09	12 - 1	1SM-1742A-00	16 - 12	1SL-21720-00	21 - 8
1SM-11190-09	1 - 17	3LD-12168-W1	3 - 14	1SM-13971-00	26 - 19	1SM-15138-00	12 - 2	1SL-17466-00	12 - 16	1SL-2172A-00	21 - 32
1SM-11193-00	1 - 23	3LD-12168-Y1	3 - 14	3TJ-14137-40	10 - 10	1SM-15155-00	12 - 4	1SM-18101-00	18 - 10	1SL-2172F-00	21 - 33
1SM-11194-00	1 - 22	3LD-12169-11	3 - 14	1SM-14147-00	10 - 12	3Y1-15361-00	13 - 8	1SL-18110-00	18 - 14	1SL-21730-00	21 - 17
5UM-1119E-00	1 - 21	3LD-12169-31	3 - 14	1SL-14171-00	10 - 4	3Y1-15363-10	13 - 6	1SL-18122-00	18 - 3	1SL-21740-01	21 - 23
1SM-11311-00	1 - 24	3LD-12169-50	3 - 14	1SM-141A1-00	10 - 13	17D-15378-00	13 - 20	1SL-18140-01	17 - 12	1DX-21746-00	21 - 13
1SM-11351-00	1 - 25	3LD-12169-70	3 - 14	1DX-14216-00	10 - 9	4JT-15381-01	12 - 20	1SL-18172-00	18 - 8	1SL-21748-00	21 - 21
1SM-11400-01	2 - 1	3LD-12169-90	3 - 14	1SL-14293-00	9 - 4	18P-15383-00	12 - 18	3XJ-18173-10	18 - 2		21 - 27
1SM-11412-00	2 - 2	3LD-12169-E0	3 - 14	33D-14325-00	10 - 5	1SM-15388-00	12 - 22	33D-18175-00	17 - 15	17D-21749-00	21 - 18
1SM-11422-00	2 - 3	3LD-12169-G0	3 - 14	33D-14348-00	10 - 6	1SM-15411-00	13 - 1	3XJ-18178-00	18 - 4		21 - 24
1SM-11454-00	2 - 13	3LD-12169-J0	3 - 14	1SL-14411-00	9 - 7	1SM-15415-00	13 - 21	3XJ-18182-00	18 - 5	5BE-21749-00	20 - 10
1SM-11455-00	2 - 9	3LD-12169-L0	3 - 14	1SL-14412-00	9 - 26	1SL-15421-00	12 - 15	3XJ-18184-00	18 - 7		21 - 10
1SM-11464-00	2 - 17	3LD-12169-N0	3 - 14	1SL-14412-10	9 - 26	1SM-15431-00	13 - 13	1SM-18185-00	18 - 1	5TA-21749-00	21 - 3
1SM-11531-00	2 - 12	3LD-12169-T0	3 - 14	1SL-14422-00	9 - 17	1SL-15441-00	12 - 13	1SM-18511-00	17 - 6		21 - 11
1SM-11536-00	2 - 8	1SM-12170-00	4 - 1	1SL-14428-00	9 - 13	1SM-15451-00	13 - 9	1SM-18512-00	17 - 7	5TJ-21757-00	9 - 38
1SM-11603-00	2 - 22	1SM-12180-10	4 - 2	1SL-14437-00	9 - 30	1SM-15453-00	13 - 22	1SM-18513-00	17 - 8	1SL-2175C-00	9 - 40
1SM-11631-01	2 - 21	5TA-12210-10	4 - 4	1SL-1443A-00	9 - 31	1SM-15462-00	13 - 17	1SL-18531-00	17 - 9	5FK-2175C-30	20 - 15
1SM-11633-00	2 - 23	4FM-12213-00	4 - 7	1SL-14442-00	9 - 24	1SM-15601-00	14 - 1	1SL-18535-00	17 - 10	1SL-2176M-00	21 - 4
1SM-11651-01	2 - 6	5EL-12214-00	4 - 5	1SL-14451-00	9 - 11	1SM-15620-00	14 - 18	1SM-18541-00	17 - 1	4XV-2177L-01	9 - 16
1SM-11681-00	2 - 4	5EL-12228-00	4 - 6	1SL-14452-00	9 - 27	1SM-15621-00	14 - 19	3D7-18542-00	17 - 2		9 - 19
1SM-116A0-01	2 - 20	1SL-12233-00	4 - 12	1SM-14453-00	9 - 8	1SM-15641-00	14 - 2	1SL-18562-00	12 - 23	1SM-217R0-20	21 - 17
1SM-12111-00	3 - 1	5BE-12241-00	1 - 18	1SL-14457-00	9 - 28	1SM-15651-00	14 - 15	1SL-21101-00	19 - 1	1SM-217R0-30	21 - 17
1SM-12113-00	3 - 6	1SM-12251-00	4 - 10	1SL-14458-00	9 - 12	5NL-15664-00	14 - 9	1SL-21163-00	19 - 37	1SM-217S0-20	21 - 23
1SM-12114-00	3 - 7	1SM-12252-10	4 - 11	1SL-14459-00	9 - 9	2NX-15668-00	14 - 12	5PA-2118K-00	20 - 16	1SM-217S0-30	21 - 23
1SM-12116-00	3 - 4	1SL-1240A-00	6 - 7	1SL-14462-00	9 - 18	2S2-15671-00	14 - 5	5PA-2118K-10	20 - 17	1SL-22110-00	22 - 1
1SM-12117-00	3 - 8	33D-12422-00	5 - 10	33D-14486-00	10 - 3	214-15674-00	14 - 11	5PA-2118K-20	20 - 16	5XC-22121-91	22 - 28
1AA-12118-00	3 - 10	33D-12427-00	5 - 11	1DX-14562-00	10 - 8	1SM-16111-00	15 - 1	1SL-21190-00	19 - 5	34P-22122-00	22 - 29
1WG-12118-00	3 - 11	1SM-12446-00	6 - 4	1SM-14611-00	11 - 1	1SM-16150-00	15 - 5	1SL-21273-00	38 - 21	2S2-22128-70	22 - 11
33M-12119-00	3 - 15	1SM-12450-00	5 - 1	5NL-14613-00	11 - 5	1SM-16154-00	15 - 6	1SL-21287-00	38 - 15	33D-22141-00	22 - 15
4TE-12119-00	3 - 3	1SM-12453-00	5 - 5	1SM-14621-00	11 - 7	1SM-16181-00	15 - 15	1SM-21335-00	19 - 35	34P-22151-01	22 - 8
1SM-12121-10	3 - 2	1SL-12461-00	6 - 8	1SL-14628-00	11 - 2	5XC-16321-00	15 - 8	1SM-21417-00	19 - 22	5UN-22176-00	23 - 15
1SM-12126-00	3 - 5	5SL-12462-00	6 - 9	1SM-14639-00	11 - 14	5NL-16325-00	15 - 9	1SM-21418-00	19 - 23	30X-22178-00	19 - 8
1SM-12127-00	3 - 9	33D-12465-00	6 - 10	1SL-1463B-00	11 - 9	1SM-16351-00	15 - 10	1SM-21425-00	19 - 29	3JD-22178-20	19 - 13
3FV-12153-09	3 - 13	1SL-12482-00	6 - 1	1SM-1466G-00	11 - 22	1SM-16356-00	15 - 19	1SM-21426-00	19 - 30	17D-2217A-00	22 - 18
5EB-12153-09	3 - 12	5NL-12564-00	5 - 16	1SM-1469A-00	11 - 23	1SM-16357-00	15 - 24	17D-21447-00	19 - 2	33D-2217F-00	22 - 24
3FV-12153-10	3 - 13	1SM-12576-00	6 - 14	1SM-1469A-10	11 - 23	5NL-16371-40	15 - 7	17D-21448-00	19 - 3	4V4-22184-00	19 - 9
5EB-12153-10	3 - 12	1SL-12577-00	6 - 15	1SL-1469F-00	11 - 25	1SM-16381-00	15 - 25	1SM-21471-00	19 - 32	5MV-22184-00	23 - 16
3LD-12168-00	3 - 14	1SM-12578-00	6 - 16	1SL-14714-00	11 - 28	1SM-16383-00	15 - 13	17D-21511-50	20 - 1	2S2-22199-70	22 - 10
3LD-12168-20	3 - 14	1SM-12579-00	6 - 17	1SL-14715-00	11 - 29	1SM-17121-00	16 - 9	17D-21511-60	20 - 1	1SM-22200-20	23 - 1
3LD-12168-40	3 - 14	1SM-13300-00	7 - 1	5VY-14747-00	11 - 15	1SM-17131-00	16 - 6	1SL-21610-00	20 - 8	1SM-22200-30	23 - 1
3LD-12168-60	3 - 14	1SL-13411-00	7 - 4	1SM-14750-00	11 - 19	1SM-17141-00	16 - 7	1SL-21610-10	20 - 8	1SM-22200-40	23 - 1
3LD-12168-80	3 - 14	5D3-13440-02	8 - 1	1SM-14750-10	11 - 19	1SM-17151-00	16 - 3	5XE-21635-10	20 - 9	1SM-22200-60	23 - 1
3LD-12168-A0	3 - 14	1SL-13447-00	8 - 2	5PX-14755-00	11 - 8	1SM-17211-00	16 - 21	17D-21642-00	20 - 13	1SM-22200-70	23 - 1
3LD-12168-F0	3 - 14	33D-13577-00	10 - 7	1SM-1477E-00	11 - 24	1SM-17221-00	16 - 13	3RV-21668-A0	22 - 32	1SM-22201-10	23 - 2

NUMERICAL INDEX

PART NO.	REF. NO.	PART NO.	REF. NO.	PART NO.	REF. NO.	PART NO.	REF. NO.	PART NO.	REF. NO.	PART NO.	REF. NO.
1SM-22201-20	23 - 2	1SM-23141-00	25 - 45	1C3-23188-R0	25 - 44	5NY-25196-00	28 - 8	1SL-25872-00	33 - 1	1SL-28386-00	9 - 37
1SM-22201-30	23 - 2	1SL-23141-10	25 - 21	1C3-23190-L0	25 - 19	34P-25304-00	30 - 10	5XC-25873-L0	35 - 12	3FV-28386-00	9 - 36
1SL-22212-00	39 - 1		25 - 45		25 - 43	17D-2530S-00	30 - 22	1C3-25876-50	35 - 17	1SL-81410-00	36 - 1
1SL-22212-10	39 - 1	1SL-23141-20	39 - 2	33D-23340-00	25 - 49	17D-25311-00	30 - 1	1C3-25886-50	35 - 15	1SL-81450-00	36 - 2
1SL-22212-20	23 - 9	1SL-23141-30	39 - 2	17D-23389-50	24 - 2	17D-25317-00	30 - 2	5MV-2589F-00	33 - 13	1SL-81528-00	36 - 7
	39 - 1	1SL-23141-40	39 - 2	17D-23416-50	24 - 6	17D-2531B-00	28 - 6	5UN-25913-00	31 - 19	1SL-81960-00	38 - 14
1SL-22212-30	23 - 9	1SL-23141-50	39 - 2	1SL-23434-00	24 - 13		30 - 15	5UN-25914-00	31 - 17	1SL-81965-00	38 - 20
	39 - 1	1SL-23141-60	39 - 2	1SL-23435-00	24 - 9	4XM-25364-00	30 - 20	5DH-25914-50	31 - 15	1SL-82309-00	38 - 24
1SL-22212-40	39 - 1	1SL-23141-70	39 - 2	18P-23441-00	24 - 11	17D-25381-00	30 - 27	3SP-25914-51	29 - 13	1SM-82310-00	38 - 11
1SL-22212-50	39 - 1	17D-23142-00	25 - 13	1SL-23442-00	24 - 12	1SL-25388-00	30 - 23	5DH-25916-00	29 - 11	33D-82370-00	38 - 1
1SL-22212-60	23 - 9		25 - 37	17D-23466-00	25 - 54	1SL-25389-00	30 - 24		31 - 14	33D-82378-00	38 - 25
	39 - 1	5XE-23144-L0	25 - 10	17D-23467-00	25 - 55	4XM-25394-00	30 - 19	3JD-25917-00	29 - 14	2C0-82380-00	10 - 15
1SL-22212-70	23 - 9		25 - 34	33D-23472-00	19 - 6	5SF-25394-00	28 - 13		31 - 16	1SL-82388-00	38 - 26
	39 - 1	17D-23145-00	25 - 8	17D-23485-50	24 - 17	5ET-25395-00	30 - 13	5DH-25919-00	29 - 6	1SL-82389-00	38 - 28
1SL-22212-80	39 - 1		25 - 32	1SL-24110-00	26 - 1	34P-25396-00	30 - 11	5DH-25919-50	31 - 6	1SL-82540-00	38 - 4
1SL-22212-90	39 - 1	5XC-23146-10	25 - 7	1SL-24115-00	26 - 6	34P-25397-00	30 - 12	8CR-25924-00	31 - 13	1SM-82590-00	38 - 23
1SL-22213-00	23 - 7		25 - 31	4EW-2412F-00	26 - 21	17D-25447-50	30 - 6	3SP-25926-51	29 - 12	17D-82911-00	37 - 1
33D-22214-00	23 - 10	1AE-23147-00	25 - 18	33D-24135-00	26 - 20	17D-25448-50	30 - 6	5DH-25933-00	29 - 10	33D-82913-00	37 - 9
33D-22224-00	23 - 11		25 - 42	1S4-2414J-00	26 - 2	17D-25449-50	30 - 6	1UY-25937-51	29 - 15	4P9-83591-00	38 - 2
4JX-22226-00	23 - 4	1C3-23147-L0	25 - 12	3FB-2415E-02	20 - 5	17D-25450-50	30 - 6		31 - 18	17D-83912-01	37 - 2
33D-22234-00	23 - 6		25 - 36	3FB-2415E-12	20 - 6	17D-25451-50	30 - 6	17D-26111-H0	32 - 1	5XC-83922-L0	33 - 12
5NY-22241-00	23 - 22	17D-23153-00	25 - 3	3FB-2415E-C1	20 - 5	17D-25452-50	30 - 6	17D-26124-00	32 - 14	1SL-83976-00	37 - 11
5XE-22242-00	23 - 19		25 - 27	4SR-2416E-00	20 - 7	5CG-25715-00	33 - 9	17D-26143-H0	32 - 15	5LP-84126-10	37 - 4
1C3-22253-50	23 - 12	5XE-23153-L0	25 - 9	1SL-24181-00	19 - 44		35 - 9	1SL-26240-00	32 - 3	1SL-85885-00	10 - 14
1C3-22253-L1	23 - 17		25 - 33	33D-24182-00	19 - 45	17D-25718-50	31 - 20	4GY-26241-00	32 - 2	8FP-85886-00	9 - 14
4AA-22259-40	23 - 8	2HH-23158-L0	25 - 23	33D-24183-00	19 - 46	5XC-2580T-G0	29 - 3	4GY-26242-00	32 - 4	1SM-8591A-40	38 - 7
4AA-22259-50	23 - 8		25 - 47	1SL-24188-00	26 - 3	17D-2580W-01	31 - 3	3Y1-26249-00	32 - 5	1SM-8591A-50	38 - 7
4AA-22259-70	23 - 8	17D-2315H-50	25 - 52	1SL-2419A-00	26 - 10	17D-2580W-11	31 - 3	5BE-26281-01	32 - 6	1SM-8591A-60	38 - 7
4EW-22474-00	23 - 14	17D-2315J-50	25 - 51	33D-24486-00	26 - 16	5XC-2581T-G0	29 - 1	5BE-26282-00	32 - 7	5XC-W0041-00	33 - 5
3JE-22475-00	23 - 13	1SM-2316A-10	25 - 14	33D-24491-00	26 - 17	1UY-25824-51	29 - 7	5SF-26287-11	32 - 9	5UN-W0042-50	35 - 2
5NY-22475-00	23 - 18		25 - 38	1SL-24610-00	26 - 4		31 - 7	1SM-26302-00	32 - 10	5XC-W0045-00	29 - 9
5UN-22898-60	31 - 12	1SM-2316A-20	25 - 14	1SL-2464E-00	27 - 3	1UY-25825-51	29 - 8	1SM-26335-00	32 - 11	1C3-W0046-50	31 - 9
1C3-22969-90	22 - 9		25 - 38	18P-2464V-00	19 - 50		31 - 8	17D-26337-00	37 - 5	1C3-W0046-B0	31 - 9
1SM-23102-10	25 - 1	1SM-23170-10	25 - 11	5YT-24665-00	6 - 11	5UN-25827-60	31 - 11	34P-26342-00	32 - 12	5KM-W0047-10	29 - 5
1SM-23102-20	25 - 1		25 - 35	18P-2467E-00	19 - 49	5UN-25828-60	31 - 10	34P-26372-00	37 - 8	5UN-W0047-50	31 - 5
1SM-23103-10	25 - 25	1SM-23170-20	25 - 11	1SL-2470F-00	27 - 2	2S2-2582W-70	31 - 1	5XC-26372-G0	33 - 17	5XC-W0057-00	29 - 4
1SM-23103-20	25 - 25		25 - 35	1SL-2470F-10	27 - 2	5MV-25833-00	33 - 16	17D-27200-51	34 - 1	5UN-W0057-50	31 - 4
1SL-23110-00	25 - 28	5XE-23171-L0	25 - 5	1SL-24710-00	27 - 1	33D-2583V-00	35 - 1	17D-27217-00	34 - 2	5XC-W2587-00	33 - 4
5XC-23111-00	25 - 22		25 - 29	1SL-24710-10	27 - 1	5XC-25849-G0	29 - 16	5UN-27217-00	35 - 8	90101-05005	37 - 7
	25 - 46	5DH-23183-00	23 - 5	1SL-24734-00	27 - 5	5UN-25852-50	35 - 5	5UN-27218-00	35 - 3	90101-06041	18 - 9
276-23114-00	25 - 24	509-23184-L0	23 - 3	1SL-24742-00	27 - 4	5XC-25852-G0	33 - 7	5UN-27222-00	35 - 4	90101-06044	14 - 13
	25 - 48	1C3-23188-L0	25 - 15	5NY-25104-00	28 - 7	5XC-25853-G0	33 - 11	34P-27311-00	34 - 16	90101-08006	30 - 25
1SL-23120-00	25 - 4		25 - 39	1SL-25111-00	28 - 1	5UN-25854-00	35 - 7	17D-27411-00	34 - 9	90105-05005	38 - 8
5XE-23125-L0	25 - 6	1C3-23188-N0	25 - 16	1SL-25117-00	28 - 3	5XC-25854-G0	33 - 6	17D-27421-00	34 - 10	90105-06027	1 - 5
	25 - 30		25 - 40	1SL-25181-00	28 - 14	5UN-2585B-00	35 - 6	17D-27491-50	31 - 22	90105-06064	21 - 29
33D-23136-00	25 - 2	1C3-23188-P0	25 - 17	1SL-25183-00	28 - 15	5CG-2585G-00	33 - 10	17D-2814F-00	19 - 48		24 - 18
	25 - 26		25 - 41	1SL-25186-00	28 - 16		35 - 10	5ET-28166-10	19 - 47		38 - 19
1SM-23141-00	25 - 21	1C3-23188-R0	25 - 20	56A-25195-00	28 - 9	5MV-25867-00	33 - 15	5PG-2816R-00	20 - 18	90105-06081	12 - 24

NUMERICAL INDEX

PART NO.	REF. NO.	PART NO.	REF. NO.	PART NO.	REF. NO.	PART NO.	REF. NO.	PART NO.	REF. NO.	PART NO.	REF. NO.
90105-06099	12 - 14	90110-06363	12 - 10	90201-08045	19 - 10	90387-06259	20 - 2	90464-17003	38 - 30	93102-08004	5 - 2
90105-06100	20 - 11	90110-06380	1 - 27	90201-08048	14 - 25	90387-06284	26 - 24	90464-18004	38 - 35	93102-08307	5 - 3
90105-06102	13 - 19	90110-06391	12 - 9		30 - 9	90387-06372	21 - 20	90464-31002	19 - 39	93102-10008	15 - 27
90105-06104	22 - 12	90110-06392	12 - 11	90201-08061	11 - 17		21 - 26		19 - 40	93102-18278	14 - 14
90105-06105	22 - 14	90201-08051	14 - 24	90201-080H1	15 - 21	90387-065T2	19 - 42	90465-08062	13 - 12	93102-28012	16 - 27
90105-06110	31 - 21	90111-06116	35 - 11	90201-08512	5 - 8	90387-066J9	38 - 18	90465-10098	38 - 32	93102-30014	28 - 4
	31 - 23	90111-06149	26 - 23	90201-096J9	1 - 14	90387-066Y6	26 - 12	90465-12356	38 - 31	93102-32337	30 - 4
	38 - 27	90116-06037	1 - 15	90201-10025	19 - 27	90387-06M31	21 - 14	90467-090A2	6 - 13	93106-22002	22 - 4
90105-06111	31 - 24	90119-06096	21 - 7	90201-10032	34 - 14	90387-07045	9 - 29	90467-140A4	1 - 20	93109-14010	18 - 16
90105-06127	20 - 3		21 - 16	90201-10035	24 - 14	90387-08032	5 - 7	90468-16001	34 - 4	93109-21001	22 - 26
90105-06148	4 - 8	90119-06262	6 - 23	90201-10045	19 - 21	90387-08041	19 - 11	90480-01027	9 - 25	93109-25001	22 - 20
90105-06156	31 - 2	90119-06268	20 - 12	90201-127E1	36 - 4	90387-08057	21 - 2	90480-01558	9 - 34	93109-28043	22 - 5
90105-06170	24 - 3	90119-06M12	18 - 15	90201-14020	22 - 30		21 - 9	90480-08608	30 - 21	93210-11073	34 - 3
	25 - 56	90119-08133	11 - 31	90201-15701	13 - 15	90387-08081	11 - 18	90480-10068	21 - 22	93210-12010	7 - 5
	26 - 7	90149-05031	36 - 5	90201-16018	22 - 17	90387-086N4	19 - 15		21 - 28	93210-14369	13 - 5
	26 - 11	90149-06074	12 - 21	90201-167P7	14 - 7	90387-087L0	9 - 22	90480-10289	26 - 13	93210-16275	6 - 5
90105-06179	21 - 30	90149-06083	2 - 14	90201-177G4	14 - 16	90387-11009	21 - 19	90480-11015	38 - 12	93210-16500	6 - 3
90105-06189	12 - 17	90149-10031	19 - 4		16 - 23		21 - 25	90480-11298	9 - 32	93210-16716	5 - 17
90105-06203	9 - 39	90151-06024	4 - 13	90201-20611	15 - 16	90387-14016	22 - 27	90480-12237	9 - 23	93210-17570	14 - 23
	19 - 34	90151-06045	14 - 22	90201-20685	14 - 3	90387-14020	18 - 11		9 - 33	93210-19123	13 - 7
	21 - 31	90151-06051	29 - 2	90201-21014	22 - 23	90387-16026	22 - 21	90480-13025	38 - 17	93210-196A4	16 - 25
	38 - 16	90151-08007	12 - 19	90201-22023	30 - 29	90387-17012	16 - 22	90480-13029	38 - 10	93210-21001	38 - 5
90105-08137	11 - 16	90159-06021	7 - 6	90201-286K9	24 - 8	90387-17015	12 - 8	90480-15012	6 - 21	93210-357A3	13 - 3
	29 - 17	90159-06027	17 - 14	90201-29M00	16 - 29	90387-17016	22 - 6	90480-18549	26 - 9	93210-45708	8 - 3
90105-08143	19 - 24	90159-06029	15 - 12	90208-10001	2 - 18	90387-1714S	22 - 7	90501-052G5	18 - 6	93300-60801	5 - 4
	19 - 31	90170-10405	2 - 19	90208-14033	2 - 15	90387-175R2	2 - 11	90501-06022	17 - 3	93300-60839	19 - 14
90105-08154	24 - 16	90170-14171	2 - 16	90208-16019	15 - 3	90387-19008	15 - 2	90501-064L1	17 - 11	93306-00426	16 - 1
	25 - 50	90170-16003	15 - 4	90209-16011	22 - 22	90387-20006	16 - 8	90501-147A5	14 - 20	93306-20336	16 - 10
90105-08230	11 - 32	90170-16326	15 - 18	90209-20008	16 - 4	90387-22033	16 - 26	90501-160A2	14 - 6	93306-20351	2 - 10
	19 - 7	90179-08019	30 - 26		16 - 18	90387-225N2	32 - 13	90501-230A6	15 - 11		16 - 24
	21 - 6	90179-10658	19 - 20	90209-23012	16 - 14	90401-10172	33 - 3	90506-20031	34 - 5	93306-20648	2 - 7
	21 - 15		19 - 26	90215-16289	15 - 17		35 - 13	90508-26080	17 - 13	93306-27209	16 - 11
90105-08232	19 - 16	90179-12657	36 - 3	90215-20003	16 - 31	90430-06014	1 - 8	90508-28015	34 - 11	93306-80502	17 - 5
90105-09004	1 - 13	90179-18001	16 - 32	90240-08120	34 - 6		5 - 15	90508-28018	34 - 12	93306-90409	17 - 4
90105-10176	19 - 19	90179-18011	28 - 17	90240-10004	34 - 13	90430-06156	7 - 3	90508-29023	18 - 12	93306-90510	30 - 3
90105-10189	19 - 28	90179-24004	24 - 10	90267-40014	9 - 35	90430-10004	38 - 3	90508-30743	14 - 10	93306-97203	28 - 2
90105-10443	19 - 25	90179-28015	24 - 7	90267-41004	9 - 35	90430-10005	33 - 2	91312-05008	19 - 36	93310-225N0	15 - 14
90109-06034	37 - 3	90185-08008	30 - 8	90267-48121	11 - 21		35 - 14	91312-06020	9 - 2	93310-63096	2 - 5
90109-06232	25 - 53	90185-08009	19 - 17	90269-06008	9 - 20	90430-10188	12 - 7	91317-06075	12 - 12	93315-32166	22 - 19
90109-08078	30 - 7	90185-10012	23 - 23	90280-03006	2 - 25	90445-09008	26 - 5	91380-06012	38 - 29		22 - 25
90110-05032	12 - 5	90185-14010	22 - 31	90340-12007	1 - 6	90450-22001	6 - 20	91402-20012	34 - 8	93317-11096	15 - 26
	36 - 8	90185-16002	22 - 16	90340-14011	13 - 4	90450-25001	6 - 19	91402-25015	34 - 15	93317-22262	22 - 2
90110-05033	7 - 2	90185-22011	30 - 28	90340-36002	13 - 2	90450-28001	6 - 18	91808-16023	1 - 4	93332-00068	24 - 5
90110-05058	26 - 18	90201-05017	11 - 3	90387-05048	38 - 9	90450-58007	9 - 6	91A20-05065	6 - 12	93332-00081	24 - 1
90110-05062	38 - 6		11 - 10	90387-06065	6 - 22	90450-60004	9 - 3	92012-06010	19 - 38	93340-21008	15 - 20
90110-05064	11 - 20	90201-06108	20 - 4	90387-06091	26 - 8	90464-13073	38 - 34	92017-05012	38 - 22	93342-22217	22 - 3
90110-05066	9 - 5	90201-08043	19 - 18	90387-06105	24 - 4	90464-13077	38 - 33	92902-10200	23 - 21	93410-20038	14 - 4
90110-06161	36 - 6	90201-08044	34 - 7	90387-06106	19 - 33	90464-15195	38 - 36	93101-14164	13 - 14	93410-22039	16 - 5

NUMERICAL INDEX

PART NO.	REF. NO.	PART NO.	REF. NO.	PART NO.	REF. NO.	PART NO.	REF. NO.	PART NO.	REF. NO.	PART NO.	REF. NO.
93410-22039	16 - 19	95612-08620	1 - 9								
93410-26067	16 - 15	95701-06500	33 - 14								
93440-07182	5 - 9	95702-06500	1 - 16								
	15 - 22		22 - 13								
93440-41178	4 - 3	95702-08500	11 - 6								
93450-17129	2 - 24	97702-40012	21 - 5								
93450-40N50	16 - 28	97702-50520	9 - 15								
93507-32009	14 - 21	97702-60016	20 - 14								
93511-32027	15 - 23	98502-05010	35 - 16								
93603-12007	5 - 6		35 - 18								
93604-10011	5 - 12	98502-05014	9 - 10								
93608-33002	18 - 13		9 - 21								
93612-16254	1 - 12	98507-05020	32 - 8								
	1 - 26	98706-04012	33 - 8								
9383B-13218	16 - 30	98707-06025	26 - 22								
94108-21027	28 - 10	98980-06008	11 - 4								
94110-19019	30 - 16		11 - 11								
94209-21229	28 - 11	99009-16400	14 - 8								
94210-19222	30 - 17	99009-17400	14 - 17								
94316-19156	30 - 18	99009-18500	15 - 28								
94330-21084	28 - 12	99009-22500	13 - 16								
94416-21045	28 - 5	99009-42700	30 - 5								
94418-19036	30 - 14	99530-08016	13 - 10								
94591-57114	4 - 9	99530-12016	13 - 18								
94682-28001	30 - 31	99530-14016	12 - 3								
	30 - 31	9Y582-28113	30 - 30								
94701-00434	1 - 10		30 - 30								
94703-00434	1 - 10										
95022-06010	1 - 7										
	5 - 14										
95022-06012	6 - 2										
95022-06016	8 - 4										
	19 - 43										
	38 - 13										
95022-06020	6 - 6										
	26 - 14										
	37 - 10										
95022-06025	5 - 13										
	13 - 23										
95022-06030	13 - 11										
95022-06060	13 - 24										
95022-08040	19 - 12										
95022-10016	12 - 6										
95024-08040	11 - 13										
	11 - 30										
95302-05600	37 - 6										
95602-10200	23 - 20										
	24 - 15										