



PARTS CATALOGUE

PW80 (4BCF) EUROPE, SOUTH AFRICA, JAPAN

PW80
PARTS CATALOGUE
©2004 by Yamaha Motor Co., Ltd.
1st edition, May 2004
All rights reserved.
Any reprinting or unauthorized use
without the written permission of
Yamaha Motor Co., Ltd.
is expressly prohibited.
Printed in Japan.

A3

PW80



A4

FOREWORD

This Parts Catalogue is related to the parts for the model(s) on the cover page. When you are ordering replacement parts, please refer to this Parts Catalogue and quote both part numbers and part names correctly.

1. Modifications or additions which have been made after the issue of the Parts Catalogue will be announced in the Parts News.

It is advisable that you make the necessary corrections to the Parts Catalogue according to the Parts News.

2. Abbreviations

The following abbreviations are used in this Parts Catalogue.

“UR” Use specified parts number.

“UN” Use as many as needed.

“AP” Alternate Parts

“LM” Locally Made (Parts need to be ordered locally)

“F#” Frame No. (Applicable machine No.)

“O/S” Over Size

3. The number of components for assembly

- Parts, which are to be supplied in an assembly, are listed with a dot (.) in front of the part name as shown below.
- The numeral appearing to the right of each component part indicates the quantity of parts for each assembly unit.

PART NO.	DESCRIPTION	Q'TY	REMARKS
2F5-83310-60	FRONT FLASHER LIGHT ASSY	2	
115-83311-60	.BULB (6V-18W)	1	

4. Applicable colours of graphics are represented in the “REMARKS” as shown below.

PART NO.	DESCRIPTION	Q'TY	REMARKS
2N4-24110-00-X5	FUEL TANK COMP.	2	MXR
3J1-24240-10	.GRAPHIC, FUEL TANK	1	FOR MXR

5. Note that the illustrations for reference in finding parts numbers are not to be used for assembling. When assembling, please use the applicable service manual.

6. The asterisk (*) before a reference number indicates modified items after the first edition.

FOREWORD

7. Applicable Serial No.

Engine Serial No.

Frame Serial No.

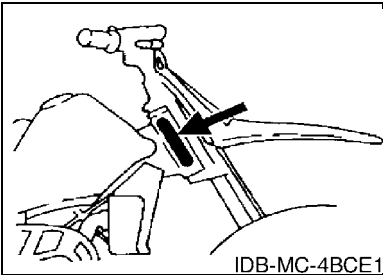
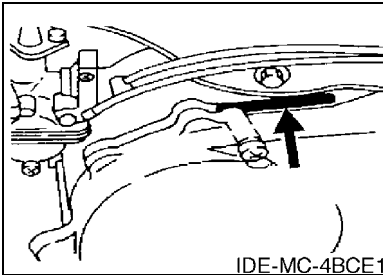

8. Applicable Colour Code (The (*) mark shows Model colour.)

Abbreviation	Colour Name	Colour Code
DPBSE(*)	DEEP PURPLISH BLUE SOLID E	0583
LGB	LOW GLOSS BLACK	0098
SL	SILVER	0035
YB	YAMAHA BLACK	0033

CONTENTS

ENGINE

CYLINDER	B2
CRANKSHAFT & PISTON	B3
OIL PUMP	B4
INTAKE	B5
CARBURETOR	B6
EXHAUST	B8
CRANKCASE	B9
CRANKCASE COVER 1	B10
STARTER	B11
CLUTCH	B12
TRANSMISSION	B14
SHIFT CAM & FORK	B15
SHIFT SHAFT	C2

CHASSIS

FRAME	C3
FRONT FENDER	C4
SIDE COVER	C5
OIL TANK	C6
REAR ARM & SUSPENSION	C7
STEERING	C8
FRONT FORK	C9
FUEL TANK	C11
SEAT	C12
FRONT WHEEL	C13
REAR WHEEL	C14
STEERING HANDLE & CABLE	D2
STAND & FOOTREST	D3
GENERATOR	D4
HANDLE SWITCH & LEVER	D5
ELECTRICAL 1	D6

INDEX

NUMERICAL INDEX	M1
-----------------------	----

FIG. 1 CYLINDER

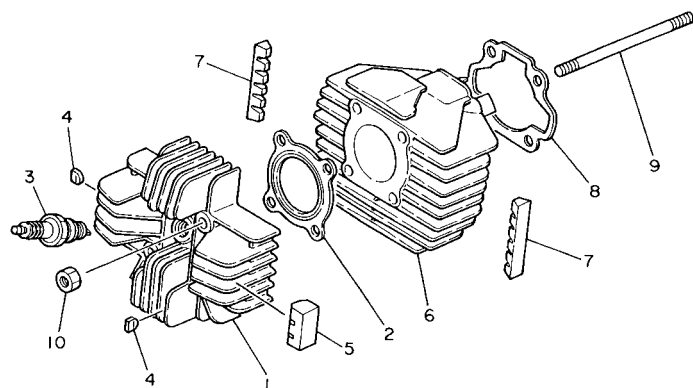

3RV110-1010

REF. NO.	PART NO.	DESCRIPTION	EUR	ZAF	JPN	REMARKS
1	21W-11111-00	HEAD, CYLINDER 1	1	1	1	
2	1W7-11181-00	GASKET, CYLINDER HEAD 1	1	1	1	
3	94701-00198	PLUG, SPARK (NGK BPR6HS)	1	1		
	94703-00198	PLUG, SPARK (NGK BPR6HS)			1	
4	463-11161-01	ABSORBER 1	4	4	4	
5	21W-11162-00	ABSORBER 2	1	1	1	
6	3E5-11311-01	CYLINDER 1	1	1	1	
7	3E5-11162-00	ABSORBER 2	2	2	2	
8	4AW-11351-00	GASKET, CYLINDER	1	1	1	
9	90116-07035	BOLT, STUD	4	4	4	
10	90179-07381	NUT	4	4	4	

FIG. 2 CRANKSHAFT & PISTON

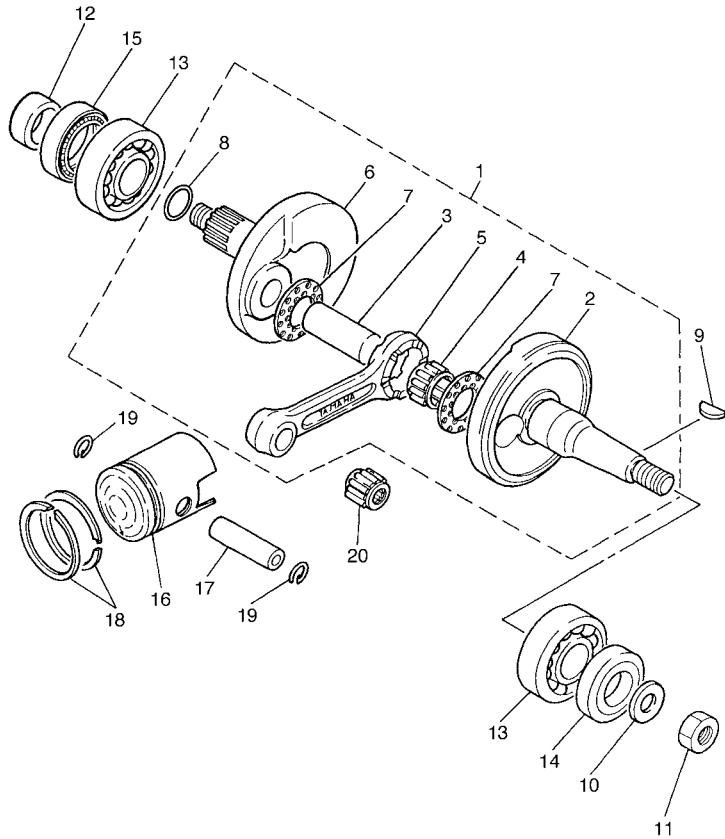

4BCE300-C020

REF. NO.	PART NO.	DESCRIPTION	EUR	ZAF	JPN	REMARKS
1	4BC-11400-00	CRANKSHAFT ASSY	1	1	1	
2	4BC-11412-00	.CRANK 1	1	1	1	
3	4BC-11681-00	.PIN, CRANK 1	1	1	1	
4	93310-420F2	.BEARING	1	1	1	
5	4BC-11651-00	.ROD, CONNECTING	1	1	1	
6	4BC-11422-00	.CRANK 2	1	1	1	
7	4BC-11557-00	.WASHER 1	2	2	2	
8	93210-18023	.O-RING	1	1	1	
9	90280-03017	KEY, WOODRUFF	1	1	1	
10	90201-12535	WASHER, PLATE	1	1	1	
11	95337-12600	NUT	1	1	1	
12	90387-20603	COLLAR	1	1	1	
13	93306-20517	BEARING (B6205)	2	2	2	
14	93103-25098	OIL SEAL	1	1	1	
15	93103-32099	OIL SEAL	1	1	1	
16	3E5-11631-00-97	PISTON (STD)	1	1	1	
	3E5-11635-00	PISTON (0.25MM O/S)	1	1	1	AP
	3E5-11636-00	PISTON (0.50MM O/S)	1	1	1	AP
17	527-11633-00	PIN, PISTON	1	1	1	
18	14N-11603-00	PISTON RING SET (STD)	1	1	1	
	14N-11604-00	PISTON RING SET (0.25MM O/S)	1	1	1	AP
	14N-11605-00	PISTON RING SET (0.50MM O/S)	1	1	1	AP
19	93450-13022	CIRCLIP	2	2	2	
20	93310-11268	BEARING	1	1	1	

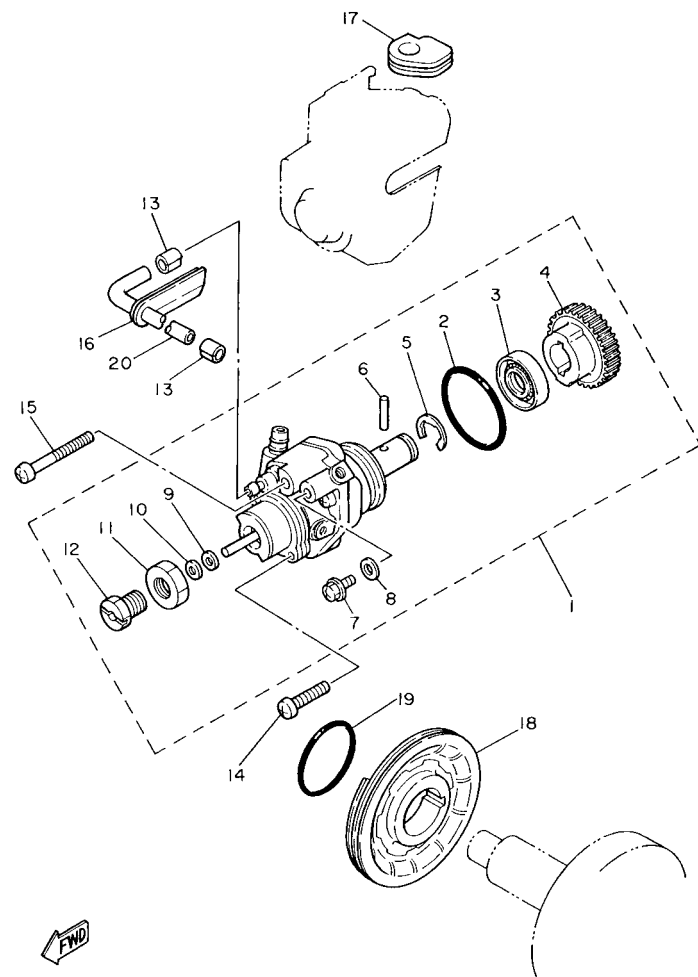

FIG. 3 OIL PUMP

REF. NO.	PART NO.	DESCRIPTION	EUR	ZAF	JPN	REMARKS
1	2T8-13101-01	OIL PUMP ASSY	1	1	1	
2	93210-26240	.O-RING	1	1	1	
3	93101-10001	.OIL SEAL	1	1	1	
4	2T5-13124-00	.GEAR, WORM WHEEL (71T)	1	1	1	
5	93430-07012	.CIRCLIP	1	1	1	
6	93603-14026	.PIN, DOWEL	1	1	1	
7	90149-04135	.SCREW	1	1	1	
8	90430-04004	.GASKET	1	1	1	
9	296-13147-00	.SHIM	1	1	1	
10	384-13138-00	.PLATE, ADJUSTING	1	1	1	
11	90170-10105	.NUT	1	1	1	
12	90401-10029	.BOLT, UNION	1	1	1	
13	90468-02033	CLIP	2	2	2	
14	98507-05020	SCREW, PAN HEAD	1	1	1	
15	98507-05035	SCREW, PAN HEAD	1	1	1	
16	90480-10005	GROMMET	1	1	1	
17	384-13174-00	HOLDER, OIL PIPE	1	1	1	
18	53F-13178-00	GEAR, PUMP DRIVE	1	1	1	
19	93210-29282	O-RING	1	1	1	
20	384-13161-02	PIPE, DELIVERY 1	1	1	1	

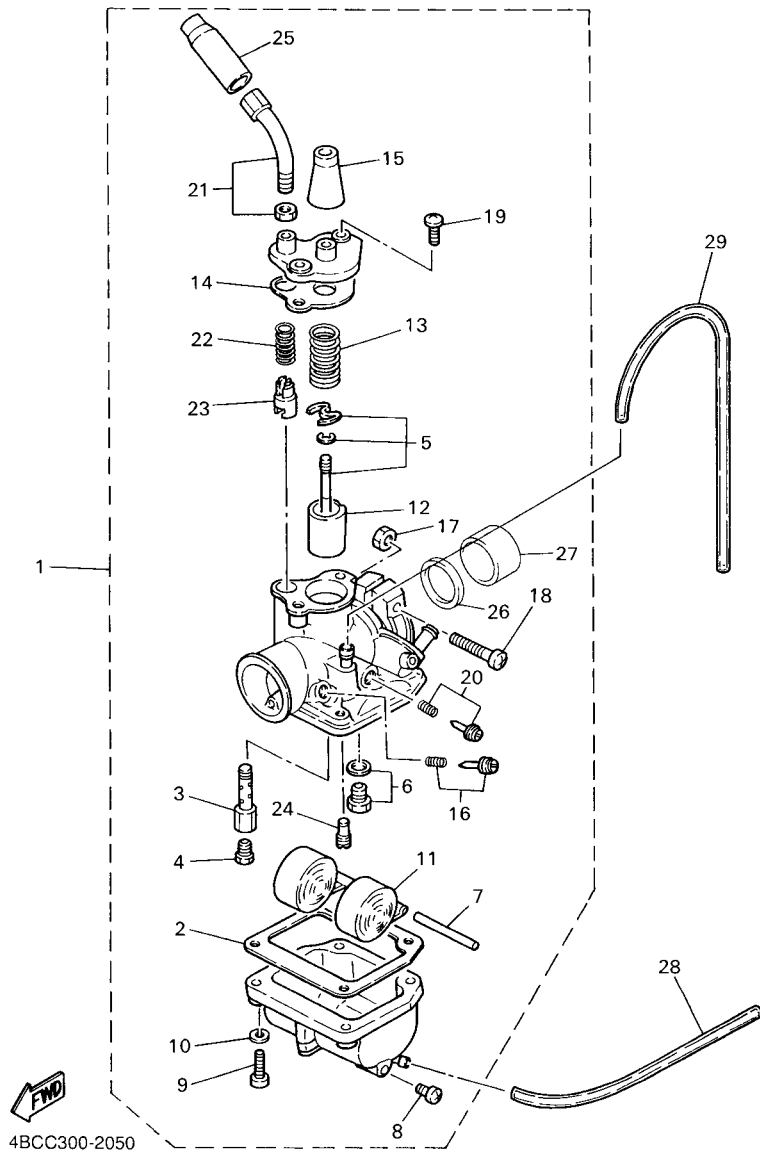

FIG. 5 CARBURETOR

REF. NO.	PART NO.	DESCRIPTION	EUR	ZAF	JPN	REMARKS
1	21W-14101-00	CARBURETOR ASSY 1	1	1	1	
2	296-14184-01	.GASKET, FLOAT CHAMBER	1	1	1	
3	127-14141-14	.NOZZLE, MAIN	1	1	1	
4	127-14143-25	.JET, MAIN (#125)	1	1	1	STD
	127-14143-24	.JET, MAIN (#120)	1	1	1	UR
	127-14143-26	.JET, MAIN (#130)	1	1	1	UR
5	21W-1490J-00	.NEEDLE SET	1	1	1	
6	21W-14107-12	.NEEDLE VALVE SET	1	1	1	
7	127-14186-00	.PIN, FLOAT	1	1	1	
8	12R-14191-00	.PLUG, DRAIN	1	1	1	
9	98502-04018	.SCREW, PAN HEAD	4	4	4	
10	92902-04100	.WASHER, SPRING	4	4	4	
11	2E9-14185-00	.FLOAT	1	1	1	
12	296-14112-25	.VALVE, THROTTLE 1	1	1	1	
13	296-14131-00	.SPRING, THROTTLE VALVE	1	1	1	
14	296-14198-01	.GASKET	1	1	1	
15	307-14169-10	.CAP	1	1	1	
16	12G-14104-00	.AIR SCREW SET	1	1	1	
17	98802-05100	.NUT	1	1	1	
18	98502-05030	.SCREW, PAN HEAD	1	1	1	
19	98502-04010	.SCREW, PAN HEAD	2	2	2	
20	12G-14103-00	.THROTTLE SCREW SET	1	1	1	
21	21W-14503-00	.ADJUST SCREW SET	1	1	1	
22	127-14135-00	.SPRING, PLUNGER	1	1	1	
23	127-14171-00	.PLUNGER, STARTER	1	1	1	
24	193-14142-15	.JET, PILOT (# 15)	1	1	1	
25	1R0-14169-00	.CAP	1	1	1	

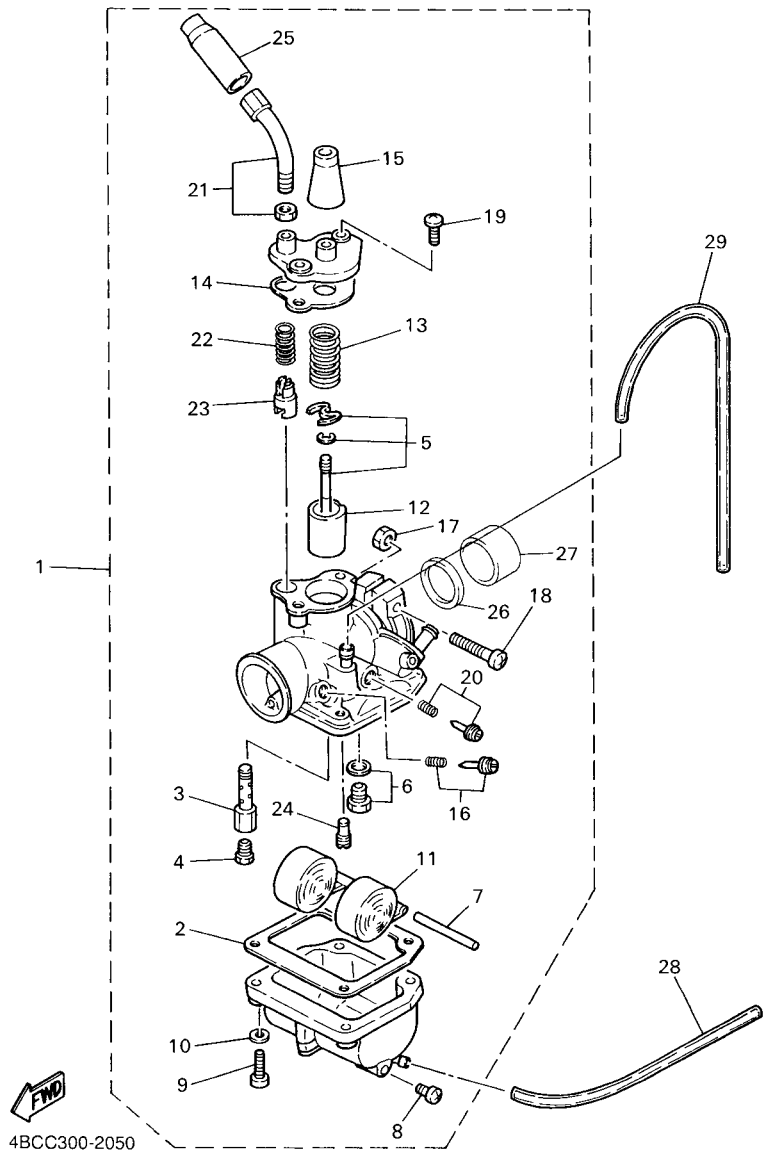
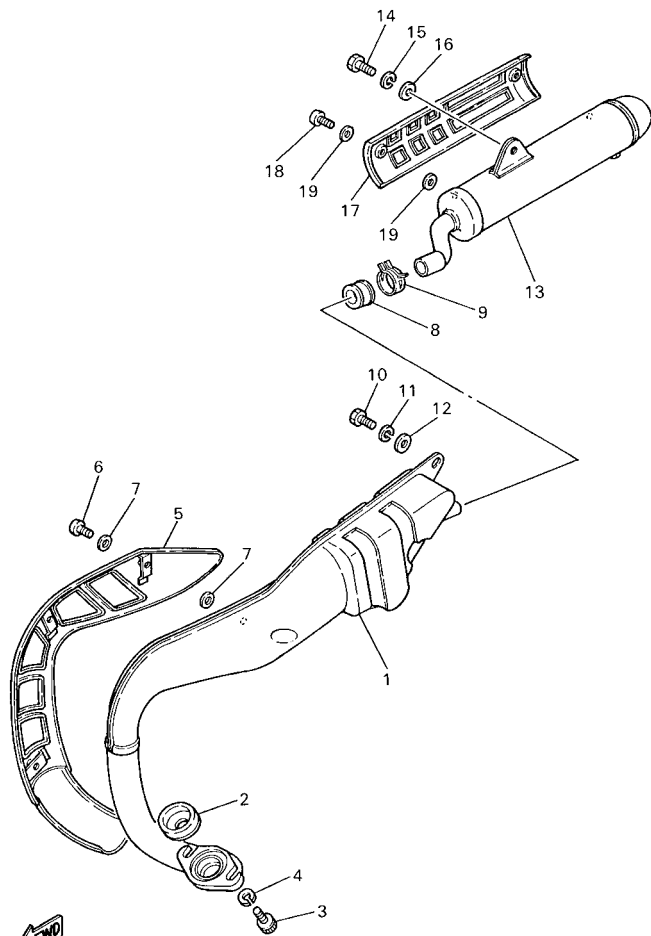

FIG. 5 CARBURETOR

REF. NO.	PART NO.	DESCRIPTION	EUR	ZAF	JPN	REMARKS
26	1M3-14997-00	.SEAL	1	1	1	
27	1V3-14271-00	.INSULATOR	1	1	1	
28	90445-05390	HOSE (L120)	1	1	1	
29	90445-07036	HOSE (L130)	1	1	1	



3RV100-5060

FIG. 6 EXHAUST

REF. NO.	PART NO.	DESCRIPTION	EUR	ZAF	JPN	REMARKS
1	21W-14610-02	EXHAUST PIPE ASSY 1	1	1	1	
2	3RV-14623-00	GASKET, EXHAUST PIPE	1	1	1	
3	97007-08020	BOLT	2	2	2	
4	92907-08100	WASHER, SPRING	2	2	2	
5	21W-14708-00	PROTECTOR ASSY	1	1	1	
6	90157-05003	SCREW, PAN HEAD	3	3	3	
7	3RV-14766-00	WASHER, PROTECTOR	6	6	6	
8	4X4-14714-00	GASKET, MUFFLER	1	1	1	
9	90467-22048	CLIP	1	1	1	
10	97007-08016	BOLT	1	1	1	
11	92907-08100	WASHER, SPRING	1	1	1	
12	92907-08600	WASHER, PLATE	1	1	1	
13	4BC-14753-00	SILENCER, EXHAUST	1	1	1	
14	97007-08016	BOLT	1	1	1	
15	92907-08100	WASHER, SPRING	1	1	1	
16	92907-08600	WASHER, PLATE	1	1	1	
17	4BC-14758-00	PROTECTOR, SILENCER	1	1	1	
18	9850M-05006	SCREW, PAN HEAD	2	2	2	
19	4BC-14766-00	WASHER, PROTECTOR	4	4	4	

FIG. 7 CRANKCASE

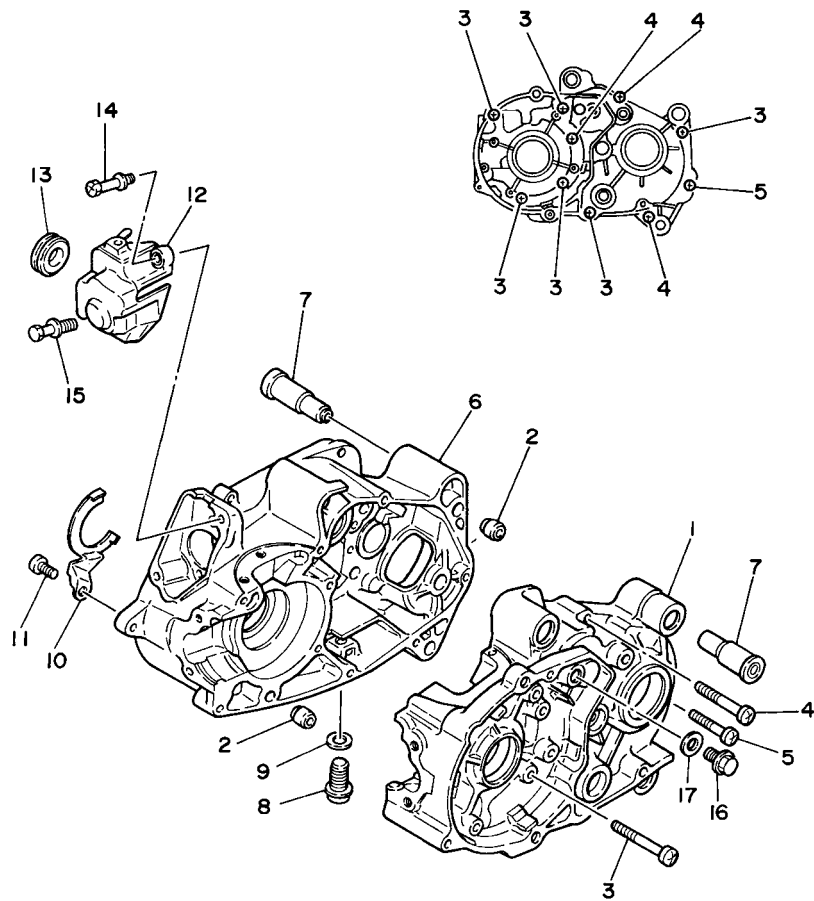

3RV110-1070

REF. NO.	PART NO.	DESCRIPTION	EUR	ZAF	JPN	REMARKS
1	1W7-15111-03	CRANKCASE 1	1	1	1	
2	99530-12016	PIN, DOWEL	2	2	2	
3	98507-06050	SCREW, PAN HEAD	6	6	6	
4	98507-06045	SCREW, PAN HEAD	3	3	3	
5	98507-06035	SCREW, PAN HEAD	1	1	1	
6	1W7-15121-03	CRANKCASE 2	1	1	1	
7	5T9-15316-01	DAMPER, ENGINE MOUNT 1	6	6	6	
8	90340-12005	PLUG, STRAIGHT SCREW	1	1	1	
9	90430-12227	GASKET	1	1	1	
10	300-15128-00	HOLDER	1	1	1	
11	98507-08010	SCREW, PAN HEAD	1	1	1	
12	517-15416-01	COVER, OIL PUMP	1	1	1	
13	90480-21038	GROMMET	1	1	1	
14	90149-06157	SCREW	1	1	1	
15	90101-06394	BOLT	1	1	1	
16	90105-10147	BOLT, FLANGE	1	1	1	
17	90430-10171	GASKET	1	1	1	

FIG. 8 CRANKCASE COVER 1

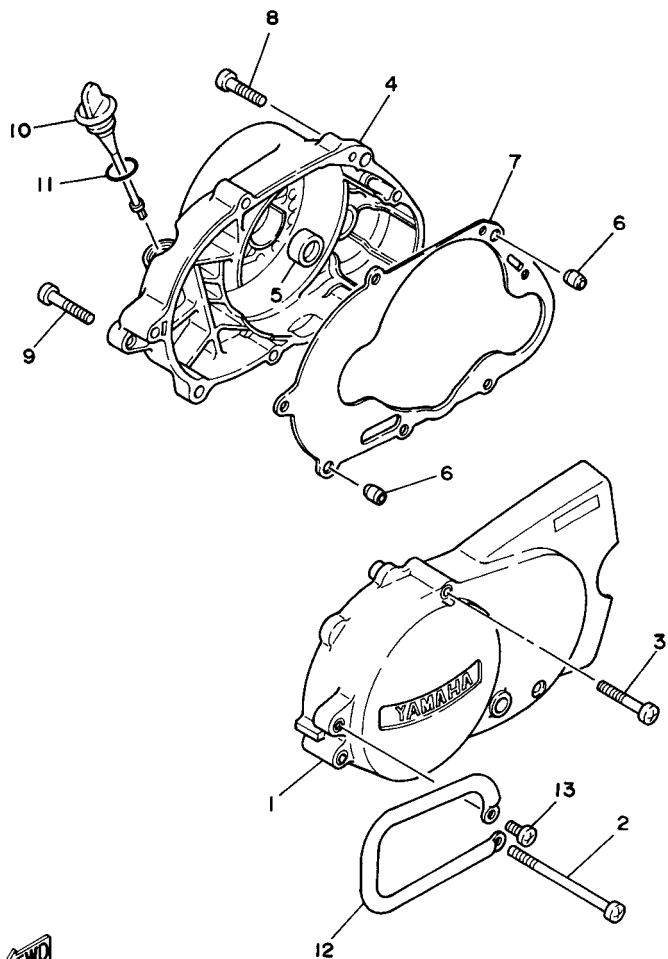

3RV110-1080

REF. NO.	PART NO.	DESCRIPTION	EUR	ZAF	JPN	REMARKS
1	21W-15411-00	COVER, CRANKCASE 1	1	1	1	
2	98507-06100	SCREW, PAN HEAD	1	1	1	
3	98507-06045	SCREW, PAN HEAD	3	3	3	
4	5R7-15421-00	COVER, CRANKCASE 2	1	1	1	
5	93104-11053	OIL SEAL	1	1	1	
6	99530-10114	PIN, DOWEL	2	2	2	
7	4AW-15451-00	GASKET, CRANKCASE COVER 1	1	1	1	
8	98507-06035	SCREW, PAN HEAD	6	6	6	
9	98507-06040	SCREW, PAN HEAD	1	1	1	
10	517-15362-02	PLUG, OIL LEVEL	1	1	1	
11	93210-19123	O-RING	1	1	1	
12	21W-15491-01	PROTECTOR	1	1	1	
13	98507-06012	SCREW, PAN HEAD	1	1	1	

B10

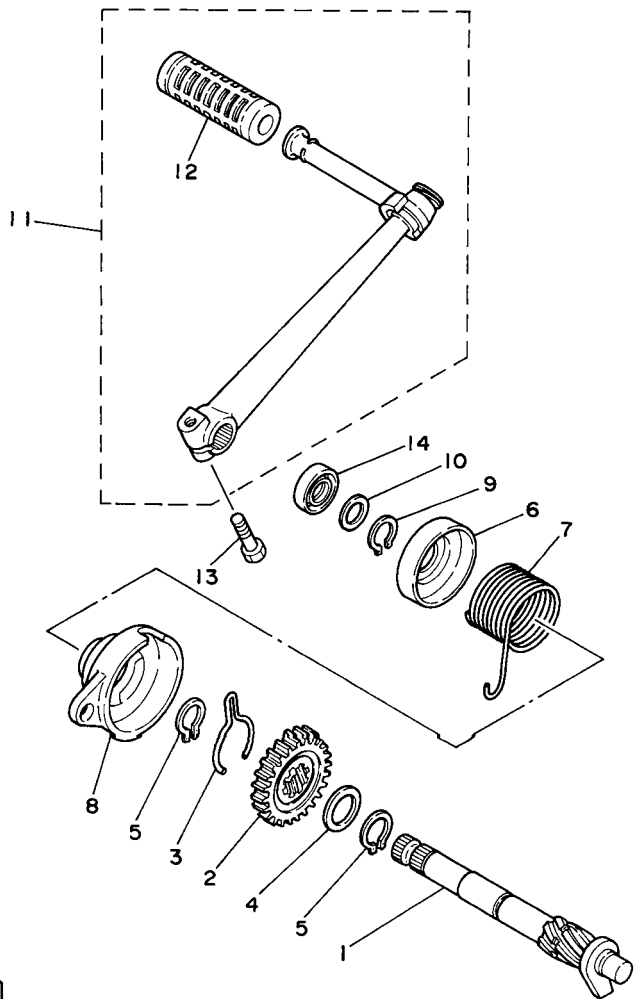

3RV110-1090

FIG. 9 STARTER

REF. NO.	PART NO.	DESCRIPTION	EUR	ZAF	JPN	REMARKS
1	4BC-15660-00	KICK AXLE ASSY	1	1	1	
2	4BC-15641-00	GEAR, KICK (21T)	1	1	1	
3	4BC-15673-00	CLIP	1	1	1	
4	4BC-15695-00	WASHER 1	1	1	1	
5	99009-20400	CIRCLIP	2	2	2	
6	4BC-15676-00	COVER, SPRING	1	1	1	
7	4BC-15665-00	SPRING, KICK	1	1	1	
8	4BC-15664-00	GUIDE, SPRING	1	1	1	
9	99009-17400	CIRCLIP	1	1	1	
10	90201-15701	WASHER, PLATE (T=1.0)	1	1	1	
11	4BC-15620-00	KICK CRANK ASSY	1	1	1	
12	4BC-15618-00	.COVER, KICK LEVER	1	1	1	
13	97017-06025	BOLT	1	1	1	
14	93109-15001	OIL SEAL	1	1	1	

B11

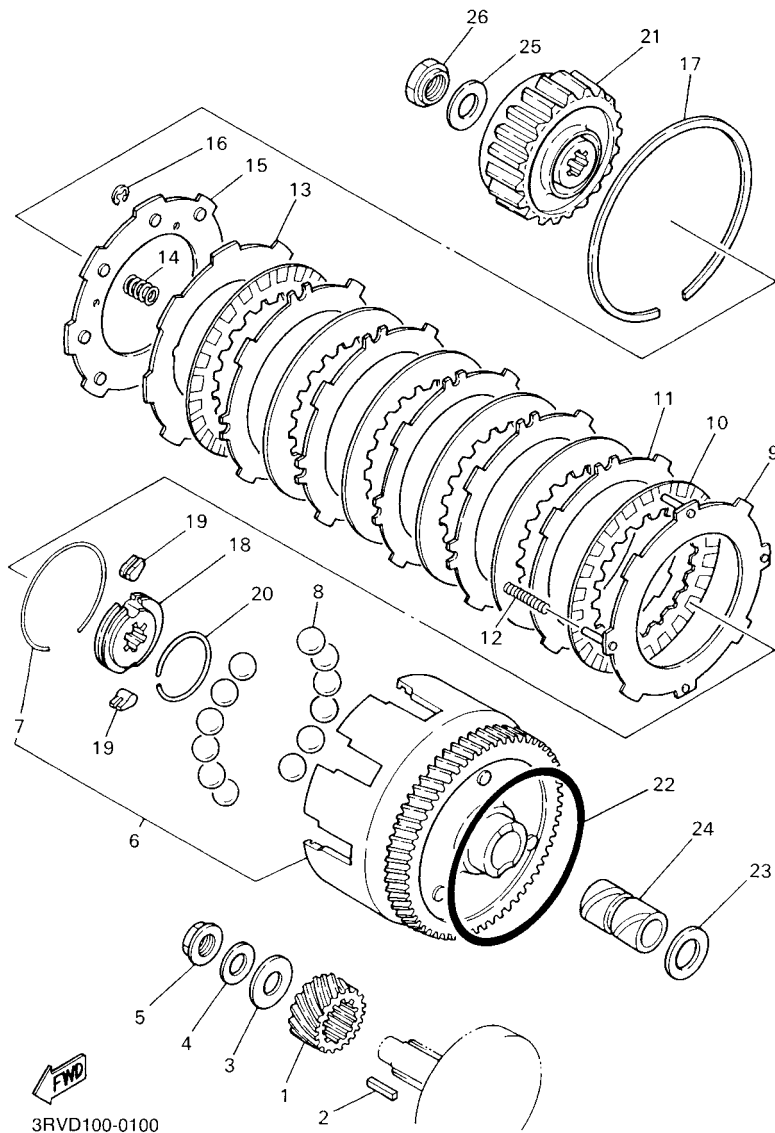
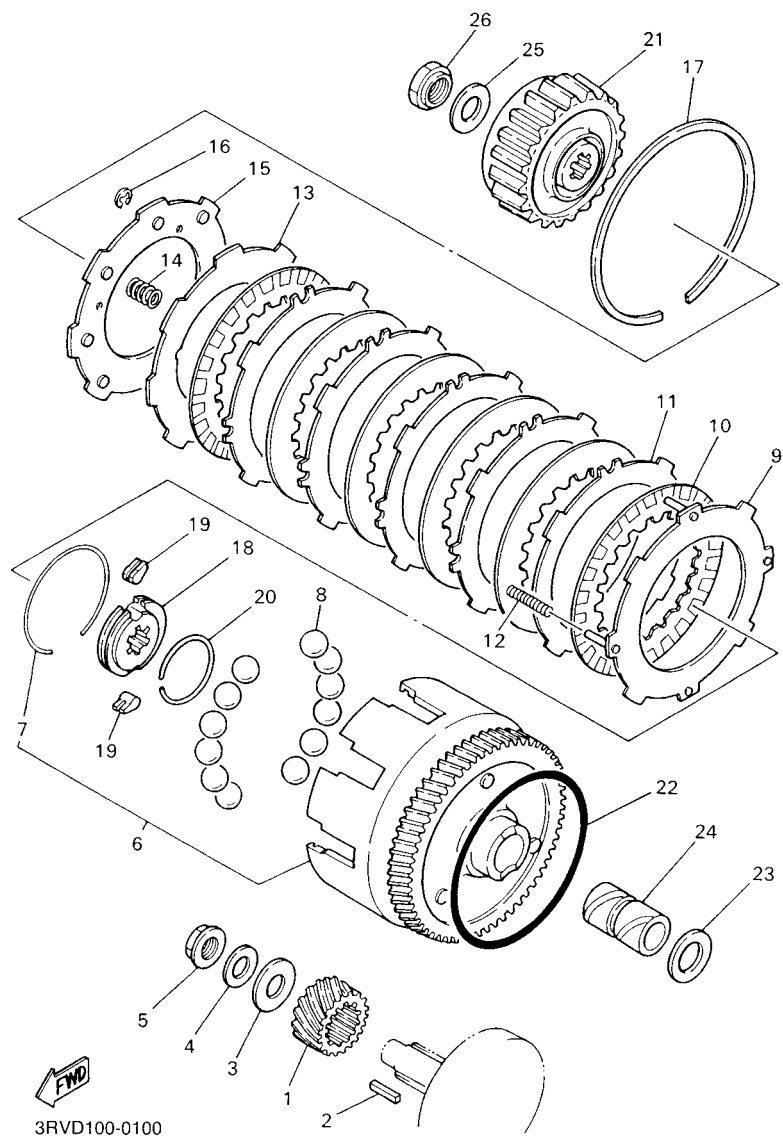

FIG. 10 CLUTCH

REF. NO.	PART NO.	DESCRIPTION	EUR	ZAF	JPN	REMARKS
1	56H-16110-00-30	PRIMARY DRIVE GEAR ASSY	1	1	1	
2	90282-04064	KEY, STRAIGHT	1	1	1	
3	90209-12280	WASHER	1	1	1	
4	90208-12015	WASHER, CONICAL SPRING	1	1	1	
5	90179-12659	NUT	1	1	1	
6	4BC-16150-00	PRIMARY DRIVEN GEAR COMP.	1	1	1	
7	90468-16090	.CLIP	1	1	1	
8	93505-08030	BALL	12	12	12	
9	527-16520-10	PLATE, THRUST WEIGHT	1	1	1	
10	3E5-16521-00	PLATE, FRICTION	6	6	6	
11	517-16524-10	PLATE, CLUTCH 1 (1.2T)	5	5	5	UR
	517-16524-20	PLATE, CLUTCH 1 (1.4T)	5	5	5	UR
	517-16524-30	PLATE, CLUTCH 1 (1.6T)	5	5	5	UR
12	90501-10602	SPRING, COMPRESSION	4	4	4	PINK
13	517-16550-10	PRESSURE PLATE ASSY	1	1	1	
14	90501-12088	SPRING, COMPRESSION	6	6	6	
15	517-16561-01	PLATE, PRESSURE 2	1	1	1	
16	99001-03600	CIRCLIP	2	2	2	
17	93451-08094	CIRCLIP	1	1	1	
18	517-16180-00	ONE WAY BOSS COMP.	1	1	1	
19	384-15635-00	PAWL, KICK	2	2	2	
20	2T4-15637-01	SPRING, PAWL	1	1	1	
21	527-16571-01	BOSS, CLUTCH	1	1	1	
22	93210-98202	O-RING	1	1	1	
23	122-16164-00	PLATE, THRUST 2	1	1	1	
24	90560-17146	SPACER	1	1	1	
25	90208-16019	WASHER, CONICAL SPRING	1	1	1	

FIG. 10 CLUTCH



REF. NO.	PART NO.	DESCRIPTION	EUR	ZAF	JPN	REMARKS
26	90179-16190	NUT	1	1	1	

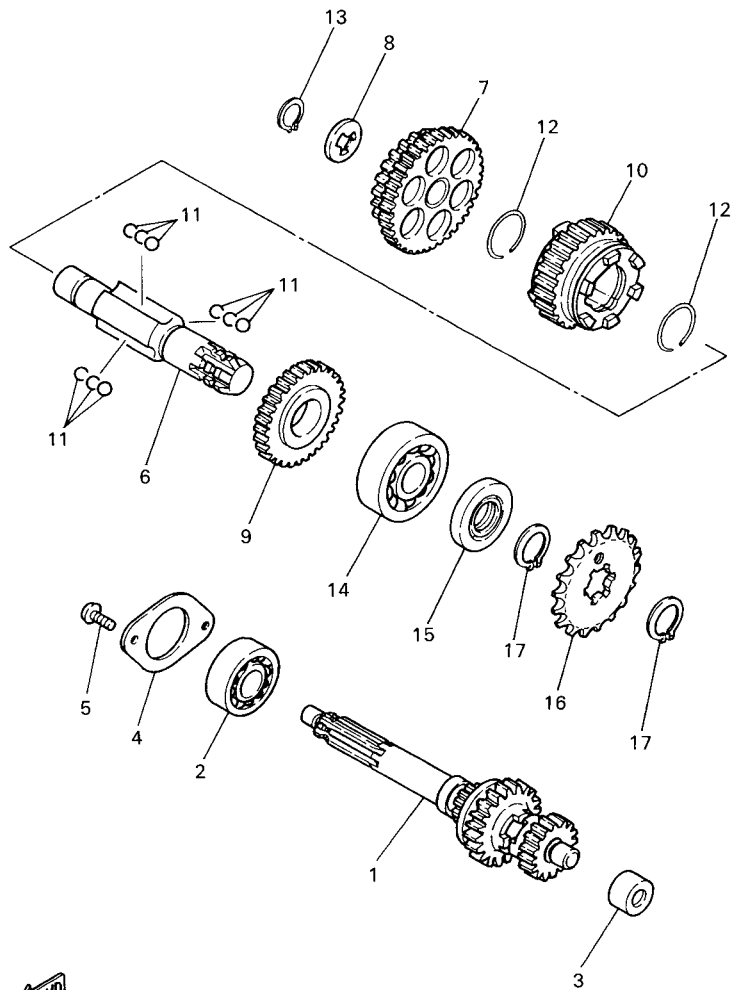

3RVG100-B110

FIG. 11 TRANSMISSION

REF. NO.	PART NO.	DESCRIPTION	EUR	ZAF	JPN	REMARKS
1	4BC-17410-00	MAIN AXLE COMP.	1	1	1	(12T/16T/17T)
2	93306-20301	BEARING	1	1	1	
3	93320-41202	BEARING (BK1212V1)	1	1	1	
4	296-17471-00	PLATE, COVER	1	1	1	
5	90157-06077	SCREW, PAN HEAD	2	2	2	
6	4BC-17421-00	AXLE, DRIVE	1	1	1	
7	4BC-17211-00	GEAR, 1ST WHEEL	1	1	1	(39T/26T)
8	90209-15178	WASHER (0.6T)	1	1	1	UR
	90209-15179	WASHER (0.8T)	1	1	1	UR
	90209-15180	WASHER (1.0T)	1	1	1	UR
9	4BC-17221-00	GEAR, 2ND WHEEL (29T)	1	1	1	
10	4BC-17231-00	GEAR, 3RD WHEEL (22T)	1	1	1	
11	4BC-17051-00	BALL, 1	9	9	9	
12	4BC-17424-00	CIRCLIP 1	2	2	2	
13	4BC-17425-00	CIRCLIP 2	1	1	1	
14	93306-20401	BEARING (B6204)	1	1	1	
15	93102-20143	OIL SEAL	1	1	1	
16	93812-15063	SPROCKET,DRIVE 15T(5171746152)	1	1	1	
17	93410-20038	CIRCLIP	2	2	2	

FIG. 12 SHIFT CAM & FORK

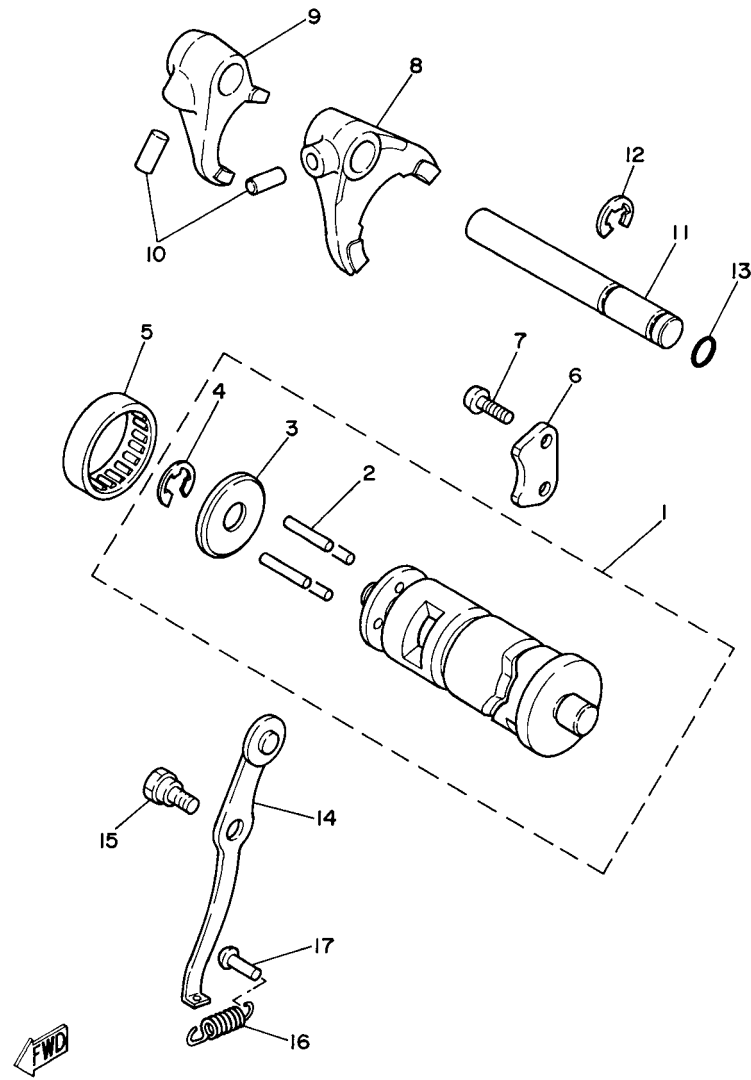

3RV110-1120

REF. NO.	PART NO.	DESCRIPTION	EUR	ZAF	JPN	REMARKS
1	21W-18540-01	SHIFT CAM ASSY	1	1	1	
2	93604-22050	.PIN, DOWEL	4	4	4	
3	296-18561-00	.PLATE, SIDE 1	1	1	1	
4	93430-09019	.CIRCLIP	1	1	1	
5	93315-23208	BEARING	1	1	1	
6	296-18562-01	PLATE, STOPPER 2	1	1	1	
7	90157-06124	SCREW, PAN HEAD	2	2	2	
8	1W7-18511-01	FORK, SHIFT 1	1	1	1	
9	1W7-18512-02	FORK, SHIFT 2	1	1	1	
10	93606-14081	PIN, DOWEL	2	2	2	
11	2N8-18531-00	BAR, SHIFT FORK GUIDE 1	1	1	1	
12	99001-10600	CIRCLIP	1	1	1	
13	93210-09729	O-RING	1	1	1	
14	296-18140-02	STOPPER LEVER ASSY	1	1	1	
15	90109-063F6	BOLT	1	1	1	
16	90506-10002	SPRING, TENSION	1	1	1	
17	132-16346-00	HOOK, SPRING	1	1	1	

B15

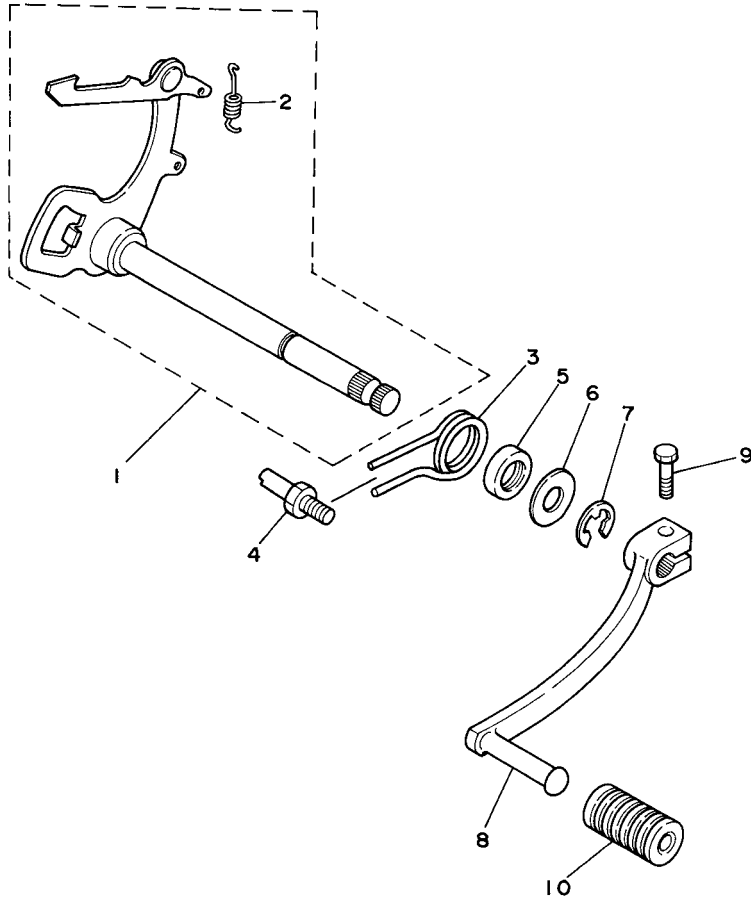

3RV110-1130

FIG. 13 SHIFT SHAFT

REF. NO.	PART NO.	DESCRIPTION	EUR	ZAF	JPN	REMARKS
1	58H-18101-04	SHIFT SHAFT ASSY	1	1	1	
2	90506-08122	.SPRING, TENSION	1	1	1	
3	90508-32263	SPRING, TORSION	1	1	1	
4	278-18127-01	STOPPER, SCREW	1	1	1	
5	93101-12004	OIL SEAL	1	1	1	
6	90201-12575	WASHER, PLATE	1	1	1	
7	99001-10600	CIRCLIP	1	1	1	
8	21W-18111-00	PEDAL, SHIFT	1	1	1	
9	97027-06020	BOLT	1	1	1	
10	132-18113-01	COVER, SHIFT PEDAL	1	1	1	

FIG. 18 REAR ARM & SUSPENSION

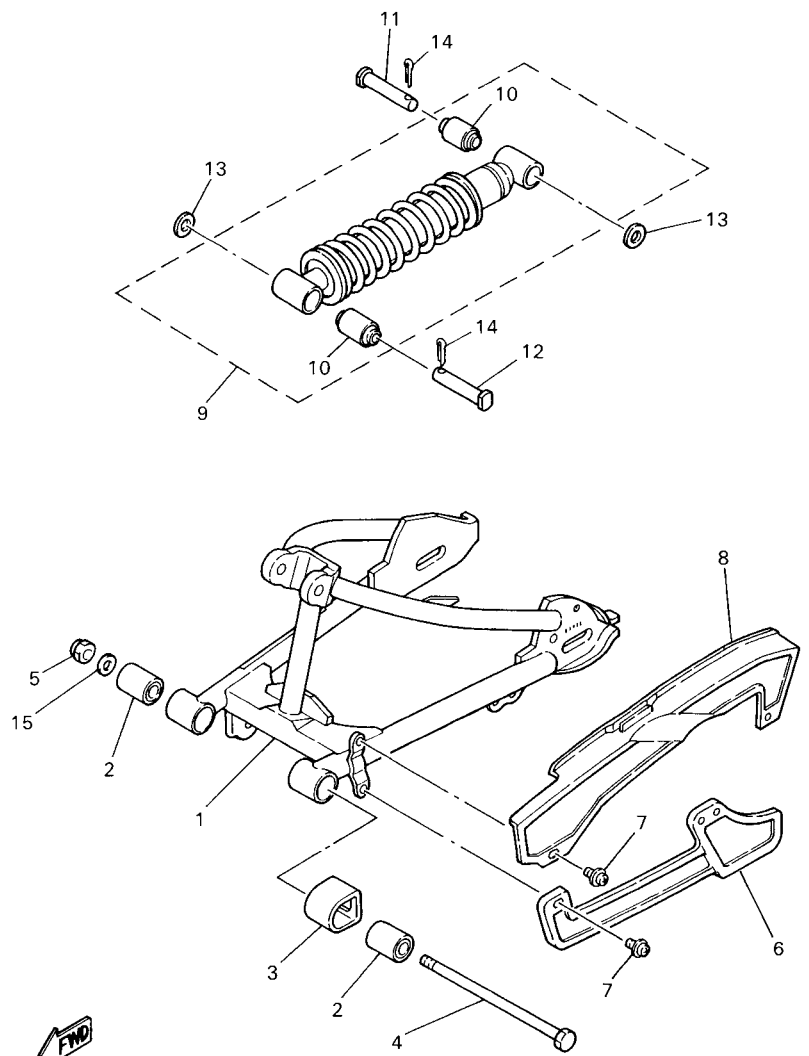

3RVG100-B180

REF. NO.	PART NO.	DESCRIPTION	EUR	ZAF	JPN	REMARKS
1	21W-22110-00-35	REAR ARM COMP.	1	1	1	SL
2	4BC-22123-00	BUSH 1	2	2	2	
3	3R0-22151-00	SEAL, GUARD	1	1	1	
4	90105-10063	BOLT, FLANGE	1	1	1	
5	90185-10037	NUT, SELF-LOCKING	1	1	1	
6	21W-22199-00	SUPPORT, CHAIN	1	1	1	
7	90119-05009	BOLT, WITH WASHER	5	5	5	
8	21W-22311-00	CASE, CHAIN	1	1	1	
9	3RV-22210-12	SHOCK ABSORBER ASSY, REAR	1	1		
	3RV-22210-22	SHOCK ABSORBER ASSY, REAR			1	
10	3M7-22216-00	.BUSH, REAR SHOCK ABSORBER	2	2	2	
11	90240-10072	PIN, CLEVIS	1	1	1	
12	90240-10069	PIN, CLEVIS	1	1	1	
13	90201-106H5	WASHER, PLATE	2	2	2	
14	91401-25020	PIN, COTTER	2	2	2	
15	90201-08759	WASHER, PLATE	1	1	1	

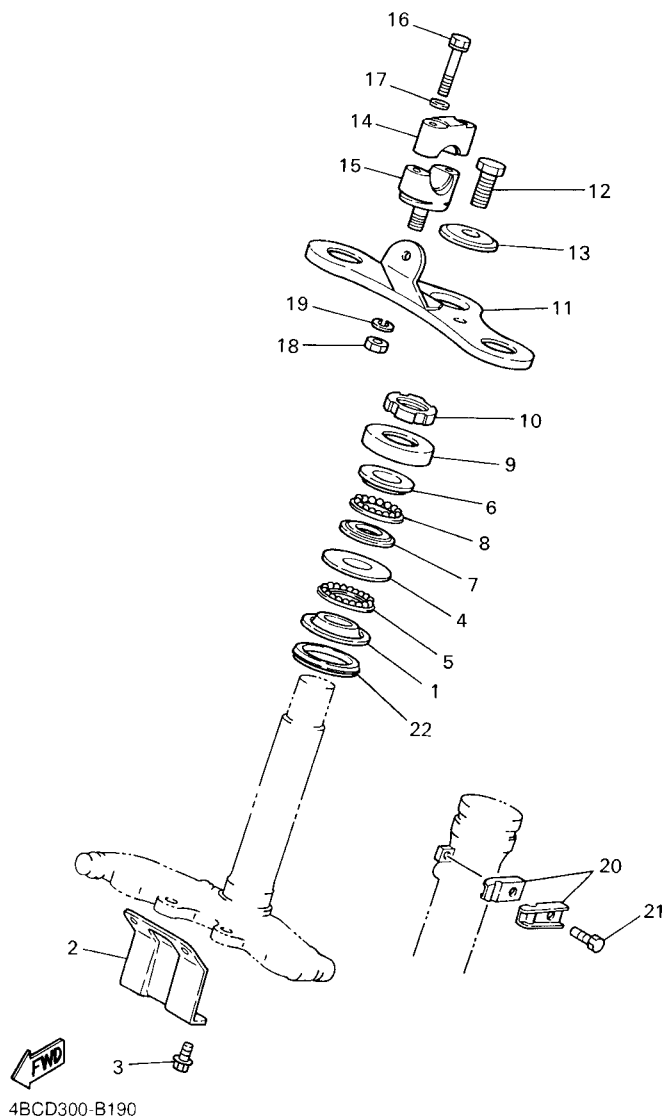
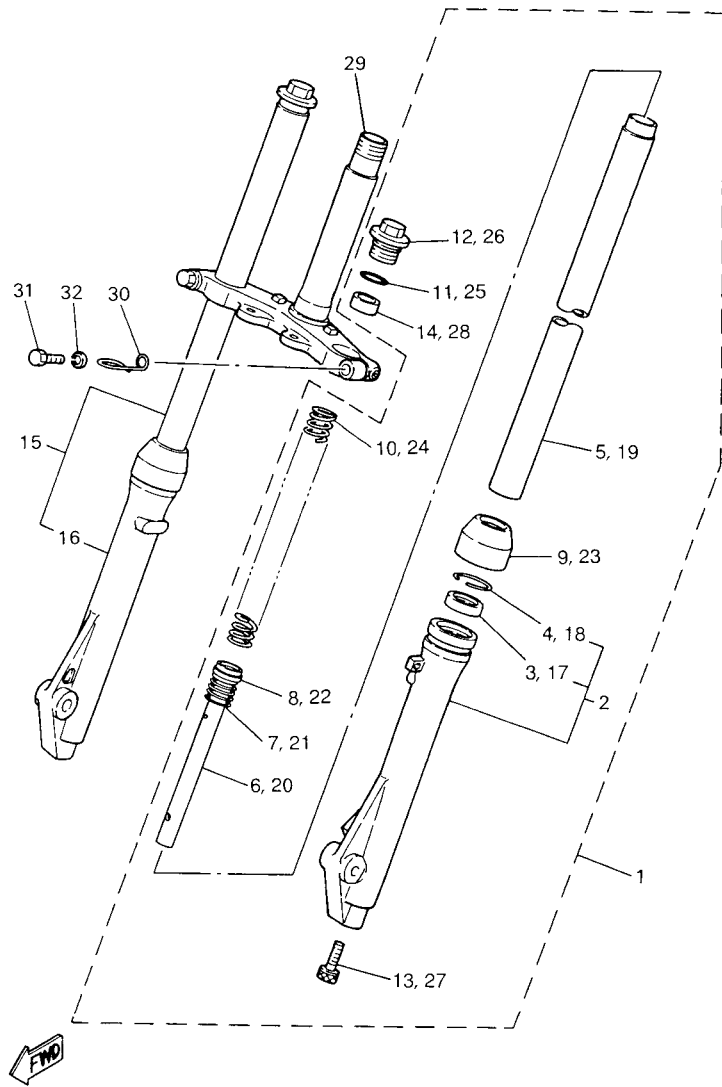

FIG. 19 STEERING

REF. NO.	PART NO.	DESCRIPTION	EUR	ZAF	JPN	REMARKS
1	156-23411-00	RACE, BALL 1	1	1	1	
2	21W-23486-00	STAY, PLATE	1	1	1	
3	5HN-23492-00	BOLT	2	2	2	
4	156-23412-00	RACE, BALL 2	1	1	1	
5	156-2341E-00	RETAINER, BALL BEARING	1	1	1	
6	22F-23411-01	RACE, BALL 1	1	1	1	
7	22F-23412-01	RACE, BALL 2	1	1	1	
8	22F-2341E-00	RETAINER, BALL BEARING	1	1	1	
9	122-23416-00	COVER, BALL RACE 2	1	1	1	
10	90179-25051	NUT	1	1	1	
11	4BC-23435-00	CROWN, HANDLE	1	1	1	
12	95817-10025	BOLT, FLANGE	1	1	1	
13	90209-10160	WASHER	1	1	1	
14	3RV-23441-01	HOLDER, HANDLE UPPER	2	2	2	
15	462-23442-00-35	HOLDER, HANDLE LOWER	2	2	2	SL
16	97014-06035	BOLT, HEXAGON	4	4	4	
17	92904-06600	WASHER	4	4	4	
18	95307-10600	NUT	2	2	2	
19	92907-10100	WASHER, SPRING	2	2	2	
20	90462-14055	CLAMP	2	2	2	
21	91317-06012	BOLT	1	1	1	
22	164-23462-00	SEAL, STEERING	1	1	1	



3RVE100-1200

FIG. 20 FRONT FORK

REF. NO.	PART NO.	DESCRIPTION	EUR	ZAF	JPN	REMARKS
1	3RV-23102-01	FRONT FORK ASSY (L.H)	1	1	1	
2	3RV-23126-01	.TUBE, OUTER (LEFT)	1	1	1	
3	3M7-23145-00	..OIL SEAL	1	1	1	
4	3M7-23156-00	..CLIP, OIL SEAL	1	1	1	
5	21W-23110-00	.INNER TUBE COMP.1	1	1	1	
6	3R0-23170-00	.CYLINDER COMP., FRONT FORK	1	1	1	
7	2J5-23151-00	.SPRING, REBOUND	1	1	1	
8	2J5-23157-00	.RING, PISTON	1	1	1	
9	3M7-23144-00	.SEAL, DUST	1	1	1	
10	21W-23141-00	.SPRING, FRONT FORK	1	1	1	
11	2J5-23147-00	.O-RING	1	1	1	
12	3M7-23111-01	.BOLT, CAP	1	1	1	
13	3M7-23181-00	.BOLT, HEXAGON SOCKET HEAD	1	1	1	WITH WASHER
14	3M7-23142-00	.SEAT, SPRING UPPER	1	1	1	
15	3RV-23103-01	FRONT FORK ASSY (R.H)	1	1	1	
16	3RV-23136-01	.TUBE, OUTER (RIGHT)	1	1	1	
17	3M7-23145-00	..OIL SEAL	1	1	1	
18	3M7-23156-00	..CLIP, OIL SEAL	1	1	1	
19	21W-23110-00	.INNER TUBE COMP.1	1	1	1	
20	3R0-23170-00	.CYLINDER COMP., FRONT FORK	1	1	1	
21	2J5-23151-00	.SPRING, REBOUND	1	1	1	
22	2J5-23157-00	.RING, PISTON	1	1	1	
23	3M7-23144-00	.SEAL, DUST	1	1	1	
24	21W-23141-00	.SPRING, FRONT FORK	1	1	1	
25	2J5-23147-00	.O-RING	1	1	1	
26	3M7-23111-01	.BOLT, CAP	1	1	1	
27	3M7-23181-00	.BOLT, HEXAGON SOCKET HEAD	1	1	1	WITH WASHER

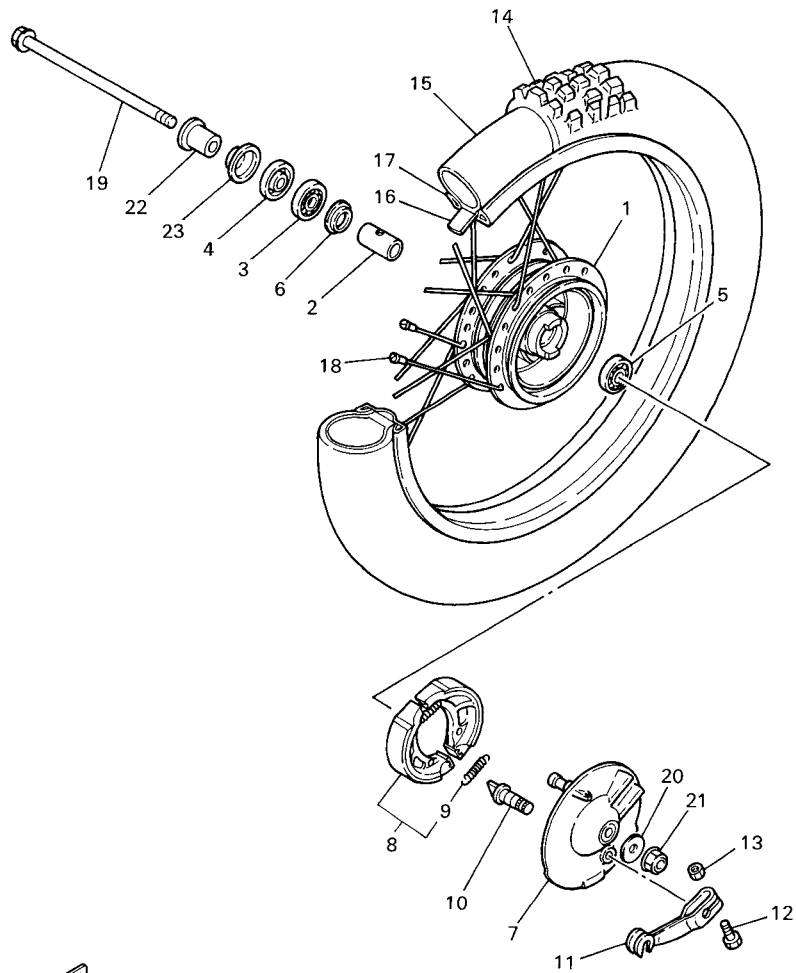

4BCC300-2230

FIG. 23 FRONT WHEEL

REF. NO.	PART NO.	DESCRIPTION	EUR	ZAF	JPN	REMARKS
1	451-25111-00-98	HUB, FRONT	1	1	1	LGB
2	90560-10103	SPACER	1	1	1	
3	93306-20004	BEARING (B6200)	1	1	1	
4	93106-17006	OIL SEAL	1	1	1	
5	93306-20009	BEARING (B6200RS)	1	1	1	
6	2E9-25116-00	FLANGE, SPACER 2	1	1	1	
7	3R0-25121-00-98	PLATE, BRAKE SHOE	1	1	1	LGB
8	3EC-W253A-00	BRAKE SHOE KIT	1	1	1	
9	90506-14081	.SPRING, TENSION	2	2	2	
10	1YT-25351-00	CAMSHAFT	1	1	1	
11	451-25155-00	LEVER, CAMSHAFT 1	1	1	1	
12	90101-06291	BOLT	1	1	1	
13	95307-06600	NUT	1	1	1	
14	94125-141A6	TIRE (2.50-14 2PR)	1	1	1	CHENG SHIN
15	94225-14215	TUBE (2.25/2.50-14 TR4)	1	1	1	CHENG SHIN
16	94325-14129	BAND, RIM (2.50-14)	1	1	1	CHENG SHIN
17	94414-14002	RIM (1.40-14)	1	1	1	
18	3R0-25104-00	SPOKE SET, FRONT	1	1	1	
19	5HN-25181-00	AXLE, WHEEL	1	1	1	
20	92907-10200	WASHER, PLAIN	1	1	1	
21	95607-10200	NUT, U FLANGE	1	1	1	
22	90387-10744	COLLAR	1	1	1	
23	451-25118-00	COVER, HUB DUST	1	1	1	

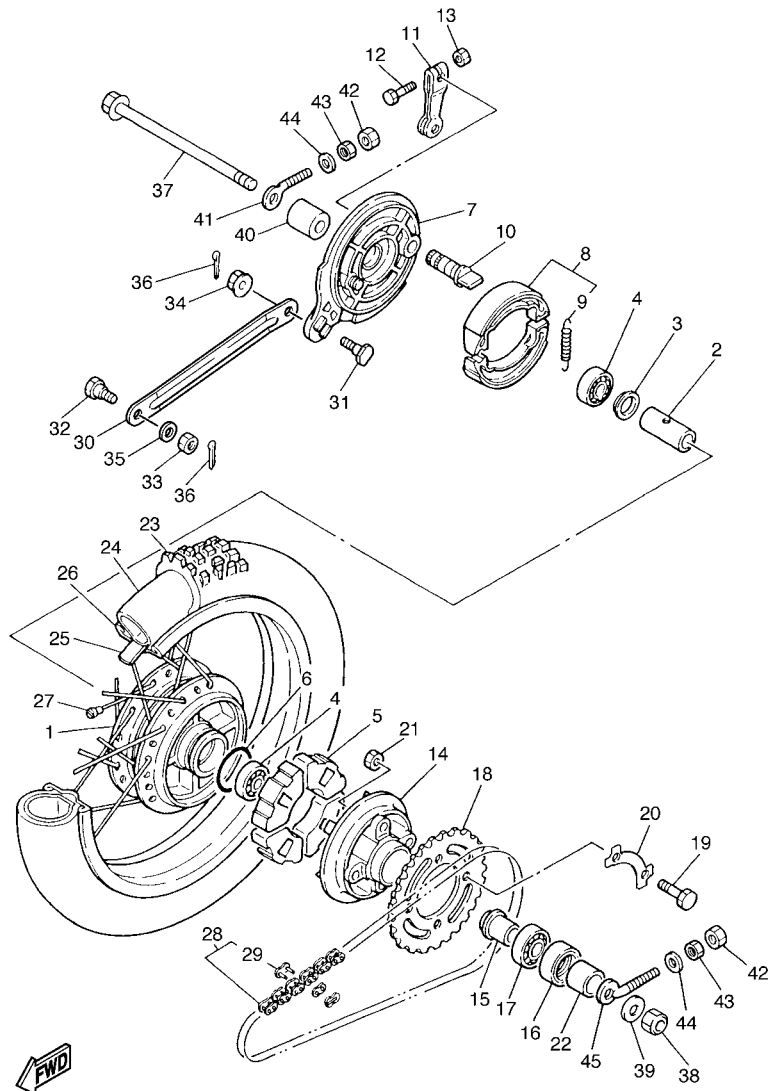

4BCF300-D240

FIG. 24 REAR WHEEL

REF. NO.	PART NO.	DESCRIPTION	EUR	ZAF	JPN	REMARKS
1	21W-25311-00-98	HUB, REAR	1	1	1	LGB
2	90560-12145	SPACER	1	1	1	
3	102-25315-00	FLANGE, SPACER	1	1	1	
4	93306-30111	BEARING	2	2	2	
5	21W-25364-00	DAMPER	4	4	4	
6	93210-41041	O-RING	1	1	1	
7	31J-25321-20-98	PLATE, BRAKE SHOE	1	1	1	LGB
8	4BE-W253E-00	BRAKE SHOE KIT	1	1	1	
9	90506-15260	.SPRING, TENSION	2	2	2	
10	3Y6-25351-00	CAMSHAFT	1	1	1	
11	538-25355-00	LEVER, CAMSHAFT	1	1	1	
12	90101-06278	BOLT	1	1	1	
13	95307-06600	NUT	1	1	1	
14	296-25366-01-98	CLUTCH, HUB	1	1	1	LGB
15	21W-25387-00	AXLE, SPROCKET	1	1	1	
16	93106-30004	OIL SEAL	1	1	1	
17	93306-00416	BEARING (B6004RS)	1	1	1	
18	21W-25432-10	SPROCKET, DRIVEN (32T)	1	1	1	
19	90101-08672	BOLT	4	4	4	
20	4AW-25412-00	WASHER	2	2	2	
21	90170-08366	NUT	4	4	4	
22	90387-207G3	COLLAR	1	1	1	
23	94130-121A7	TIRE (3.00-12 2PR)	1	1	1	CHENG SHIN
24	94227-12216	TUBE (2.75/3.00-12 TR4)	1	1	1	CHENG SHIN
25	94330-12130	BAND, RIM (3.00-12)	1	1	1	CHENG SHIN
26	94416-12003	RIM (1.60-12)	1	1	1	
27	21W-25304-00	SPOKE SET, REAR	1	1	1	

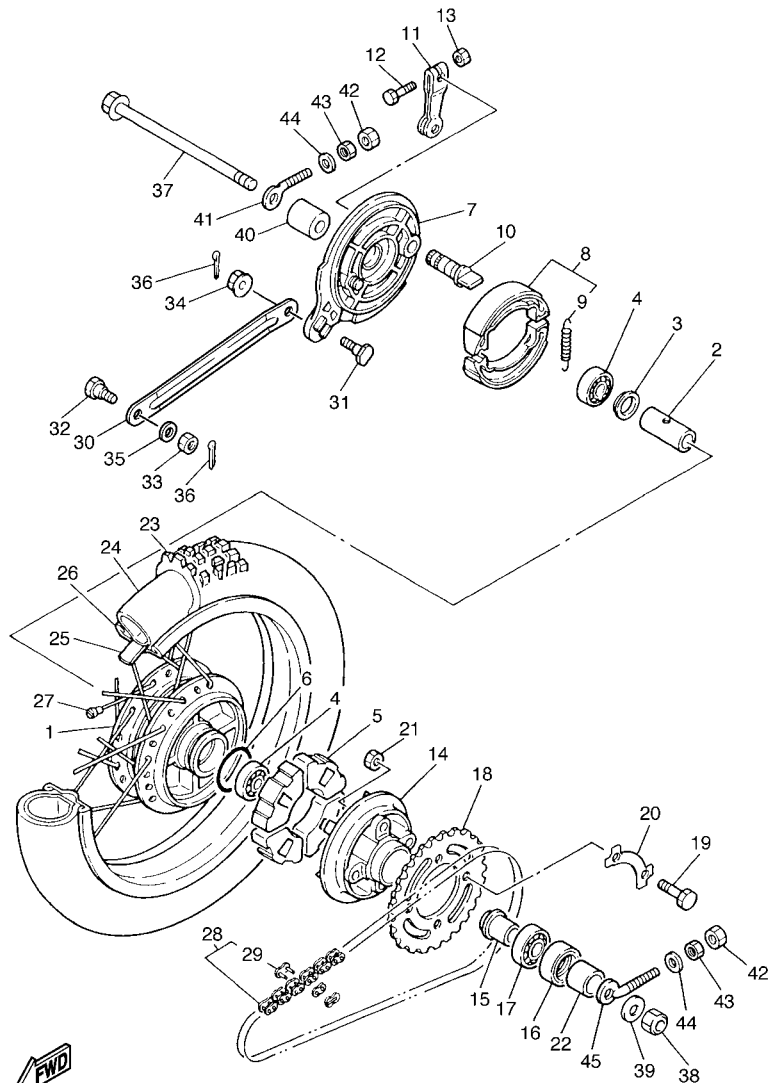

4BCF300-D240

FIG. 24 REAR WHEEL

REF. NO.	PART NO.	DESCRIPTION	EUR	ZAF	JPN	REMARKS
28	94561-66084	CHAIN (KMC420 84L)	1	1	1	
29	94661-66001	.JOINT, CHAIN (KMC420)	1	1	1	
30	4BC-25371-00	BAR, TENSION	1	1	1	
31	90109-08183	BOLT	1	1	1	
32	90109-08368	BOLT	1	1	1	
33	95307-08700	NUT	1	1	1	
34	95707-08500	NUT, FLANGE	1	1	1	
35	92907-08600	WASHER, PLATE	1	1	1	
36	91401-20012	PIN, COTTER	2	2	2	
37	5HN-25381-00	AXLE, WHEEL	1	1	1	
38	90185-12134	NUT, SELF-LOCKING	1	1	1	
39	90201-126A7	WASHER, PLATE	1	1	1	
40	90387-12412	COLLAR	1	1	1	
41	3AC-25389-00	PULLER, CHAIN 2	1	1	1	
42	95307-06600	NUT	2	2	2	
43	90170-06184	NUT	2	2	2	
44	90201-061A5	WASHER, PLATE	2	2	2	
45	4GL-25389-00	PULLER, CHAIN 2	1	1	1	

FIG. 25 STEERING HANDLE & CABLE

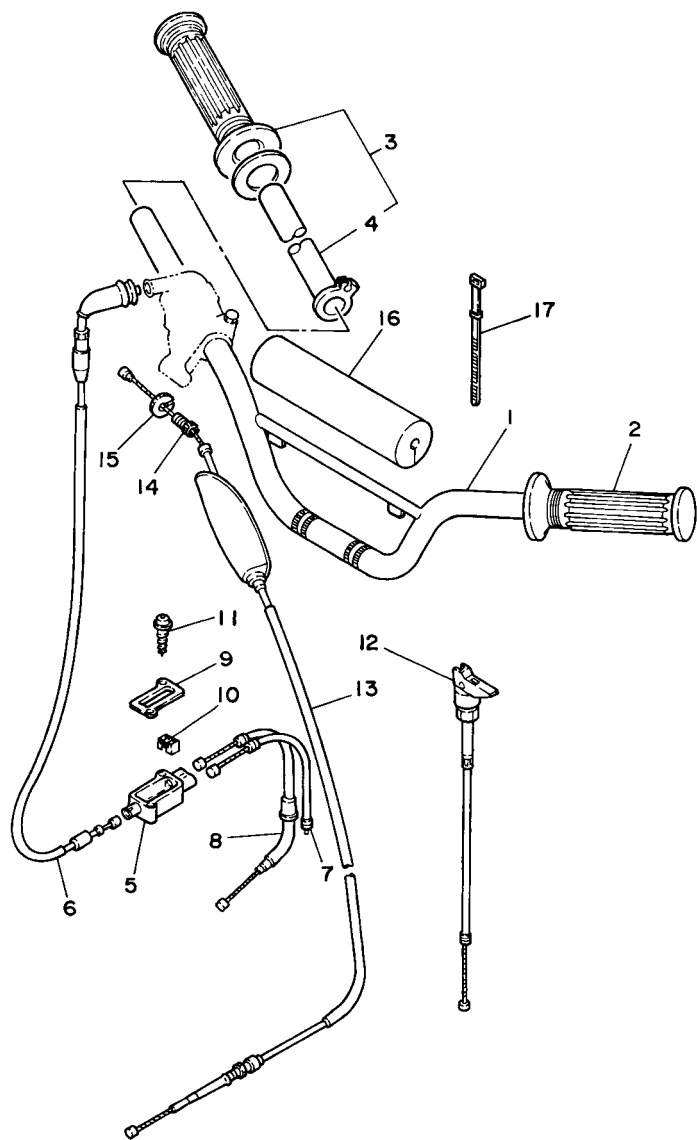

3RV110-1250

REF. NO.	PART NO.	DESCRIPTION	EUR	ZAF	JPN	REMARKS
1	3RV-26111-00	HANDLEBAR	1	1	1	
2	2N3-26241-00	GRIP	1	1	1	BLACK
3	21W-26240-00	GRIP ASSY	1	1	1	
4	434-26243-12	.TUBE, THROTTLE GUIDE	1	1	1	
5	4BC-26261-00	CONNECTOR, CABLE	1	1	1	
6	4BC-26311-00	CABLE, THROTTLE 1	1	1	1	
7	4BC-26312-00	CABLE, THROTTLE 2	1	1	1	
8	4BC-26321-00	CABLE, PUMP	1	1	1	
9	4BC-26262-00	CAP, CABLE CONNECTOR	1	1	1	
10	4BC-26263-00	PIECE, CONNECTING	1	1	1	
11	90167-03004	SCREW, TAPPING	2	2	2	
12	4BC-26331-00	CABLE, STARTER 1	1	1	1	
13	4BC-26341-00	CABLE, BRAKE	1	1	1	
14	90123-08013	BOLT	1	1	1	
15	90179-08148	NUT	1	1	1	
16	21W-26124-00	PROTECTOR, HANDLEBAR	1	1	1	
17	437-83936-11	BAND, SWITCH CORD	2	2	2	

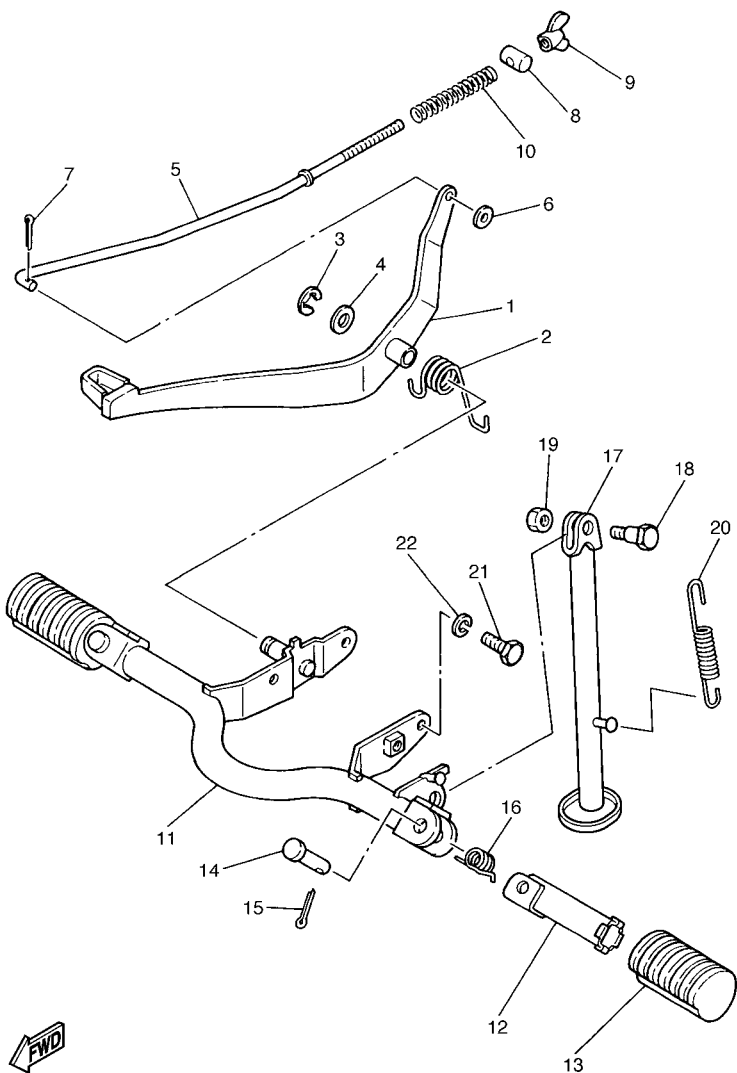

4BCE300-C260

FIG. 26 STAND & FOOTREST

REF. NO.	PART NO.	DESCRIPTION	EUR	ZAF	JPN	REMARKS
1	21W-27211-00	PEDAL, BRAKE	1	1	1	
2	90508-29578	SPRING, TORSION	1	1	1	
3	99001-09600	CIRCLIP	1	1	1	
4	92907-12600	WASHER, PLATE	1	1	1	
5	21W-27231-00	ROD, BRAKE	1	1	1	
6	92907-06600	WASHER, PLATE	1	1	1	
7	91401-20012	PIN, COTTER	1	1	1	
8	90249-12008	PIN	1	1	1	
9	90175-06013	NUT, WING	1	1	1	
10	90501-10245	SPRING, COMPRESSION	1	1	1	
11	21W-27411-01-33	FOOTREST 1	1	1	1	YB
12	214-27421-00	FOOTREST 2	2	2	2	
13	214-27413-00	COVER, FOOTREST	2	2	2	
14	90240-08084	PIN, CLEVIS	2	2	2	
15	91401-25015	PIN, COTTER	2	2	2	
16	90508-20023	SPRING, TORSION	2	2	2	
17	4BC-27311-00	STAND, SIDE	1	1	1	
18	90109-08666	BOLT	1	1	1	
19	95307-08700	NUT	1	1	1	
20	90506-28100	SPRING, TENSION	1	1	1	
21	97027-08020	BOLT	2	2	2	
22	92907-08100	WASHER, SPRING	2	2	2	

NUMERICAL INDEX

PART NO.	GRID NO.	PART NO.	GRID NO.	PART NO.	GRID NO.	PART NO.	GRID NO.	PART NO.	GRID NO.	PART NO.	GRID NO.
21W-11111-00	B - 2	296-14184-01	B - 6	517-16180-00	B - 12	3RV-22210-22	C - 7	3RV-24770-40	C - 12	4BC-82913-00	D - 5
463-11161-01	B - 2	2E9-14185-00	B - 6	132-16346-00	B - 15	3M7-22216-00	C - 7	3R0-25104-00	C - 13	4BC-82921-00	D - 5
21W-11162-00	B - 2	127-14186-00	B - 6	527-16520-10	B - 12	21W-22311-00	C - 7	451-25111-00-98	C - 13	4BC-83922-00	D - 5
3E5-11162-00	B - 2	12R-14191-00	B - 6	3E5-16521-00	B - 12	3RV-23102-01	C - 9	2E9-25116-00	C - 13	437-83936-01	D - 5
1W7-11181-00	B - 2	296-14198-01	B - 6	517-16524-10	B - 12	3RV-23103-01	C - 9	451-25118-00	C - 13	437-83936-11	D - 2
3E5-11311-01	B - 2	1V3-14271-00	B - 7	517-16524-20	B - 12	21W-23110-00	C - 9	3R0-25121-00-98	C - 13		D - 5
4AW-11351-00	B - 2	4BC-14412-00	B - 5	517-16524-30	B - 12	3M7-23111-01	C - 9	451-25155-00	C - 13	21W-83976-00	D - 5
4BC-11400-00	B - 3	4BC-14451-00	B - 5	517-16550-10	B - 12	3RV-23126-01	C - 9	5HN-25181-00	C - 13	4BC-85510-00	D - 4
4BC-11412-00	B - 3	4BC-14453-00	B - 5	517-16561-01	B - 12	3RV-23136-01	C - 9	21W-25304-00	C - 14	4BC-85512-00	D - 4
4BC-11422-00	B - 3	4BC-14454-00	B - 5	527-16571-01	B - 12	21W-23141-00	C - 9	21W-25311-00-98	C - 14	4BC-85540-00	D - 6
4BC-11557-00	B - 3	4BC-14455-00	B - 5	4BC-17051-00	B - 14	3M7-23142-00	C - 9	102-25315-00	C - 14	4BC-85550-00	D - 4
14N-11603-00	B - 3	4BC-14457-00	B - 5	4BC-17211-00	B - 14	3M7-23144-00	C - 9	31J-25321-20-98	C - 14	4BC-W1441-00	B - 5
14N-11604-00	B - 3	4BC-14458-00	B - 5	4BC-17221-00	B - 14	3M7-23145-00	C - 9	1YT-25351-00	C - 13	3EC-W253A-00	C - 13
14N-11605-00	B - 3	21W-14503-00	B - 6	4BC-17231-00	B - 14	2J5-23147-00	C - 9	3Y6-25351-00	C - 14	4BE-W253E-00	C - 14
3E5-11631-00-97	B - 3	21W-14610-02	B - 8	4BC-17410-00	B - 14	2J5-23151-00	C - 9	538-25355-00	C - 14	90101-06278	C - 14
527-11633-00	B - 3	3RV-14623-00	B - 8	4BC-17421-00	B - 14	3M7-23156-00	C - 9	21W-25364-00	C - 14	90101-06291	C - 13
3E5-11635-00	B - 3	21W-14708-00	B - 8	4BC-17424-00	B - 14	2J5-23157-00	C - 9	296-25366-01-98	C - 14	90101-06394	B - 9
3E5-11636-00	B - 3	4X4-14714-00	B - 8	4BC-17425-00	B - 14	3R0-23170-00	C - 9	4BC-25371-00	C - 15	90101-08286	C - 3
4BC-11651-00	B - 3	4BC-14753-00	B - 8	296-17471-00	B - 14	3M7-23181-00	C - 9	5HN-25381-00	C - 15	90101-08672	C - 14
4BC-11681-00	B - 3	4BC-14758-00	B - 8	58H-18101-04	C - 2	3R0-23318-00	C - 10	21W-25387-00	C - 14	90105-10063	C - 7
2T8-13101-01	B - 4	3RV-14766-00	B - 8	21W-18111-00	C - 2	5HN-23340-00	C - 10	3AC-25389-00	C - 15	90105-10147	B - 9
2T5-13124-00	B - 4	4BC-14766-00	B - 8	132-18113-01	C - 2	451-23346-00	C - 10	4GL-25389-00	C - 15	90109-063F6	B - 15
384-13138-00	B - 4	21W-1490J-00	B - 6	278-18127-01	C - 2	156-23411-00	C - 8	4AW-25412-00	C - 14	90109-06798	D - 5
296-13147-00	B - 4	1M3-14997-00	B - 7	296-18140-02	B - 15	22F-23411-01	C - 8	21W-25432-10	C - 14	90109-08183	C - 15
384-13161-02	B - 4	1W7-15111-03	B - 9	1W7-18511-01	B - 15	156-23412-00	C - 8	3RV-26111-00	D - 2	90109-08368	C - 15
384-13174-00	B - 4	1W7-15121-03	B - 9	1W7-18512-02	B - 15	22F-23412-01	C - 8	21W-26124-00	D - 2	90109-08666	D - 3
53F-13178-00	B - 4	300-15128-00	B - 9	2N8-18531-00	B - 15	122-23416-00	C - 8	21W-26240-00	D - 2	90116-07035	B - 2
21W-13555-00	B - 5	5T9-15316-01	B - 9	21W-18540-01	B - 15	156-2341E-00	C - 8	2N3-26241-00	D - 2	90119-05009	C - 7
300-13610-04	B - 5	517-15362-02	B - 10	296-18561-00	B - 15	22F-2341E-00	C - 8	434-26243-12	D - 2	90119-06044	C - 4
300-13613-02	B - 5	21W-15411-00	B - 10	296-18562-01	B - 15	4BC-23435-00	C - 8	4BC-26261-00	D - 2	90119-06056	C - 6
300-13616-00	B - 5	517-15416-01	B - 9	21W-21110-10-33	C - 3	3RV-23441-01	C - 8	4BC-26262-00	D - 2	90123-08013	D - 2
300-13621-10	B - 5	5R7-15421-00	B - 10	3RV-21511-20	C - 4	462-23442-00-35	C - 8	4BC-26263-00	D - 2	90149-04135	B - 4
300-13622-10	B - 5	4AW-15451-00	B - 10	4ES-2153E-01	C - 4	164-23462-00	C - 8	4BC-26311-00	D - 2	90149-06011	C - 11
21W-14101-00	B - 6	21W-15491-01	B - 10		C - 5	21W-23486-00	C - 8	4BC-26312-00	D - 2	90149-06157	B - 9
12G-14103-00	B - 6	4BC-15618-00	B - 11	3RV-21569-31	C - 4	5HN-23492-00	C - 8	4BC-26321-00	D - 2	90151-05055	D - 4
12G-14104-00	B - 6	4BC-15620-00	B - 11	21W-21621-00	C - 5	3RV-24110-20	C - 11	4BC-26331-00	D - 2	90157-05003	B - 8
21W-14107-12	B - 6	384-15635-00	B - 12	21W-21646-00	C - 6	59V-24173-00	C - 11	4BC-26341-00	D - 2	90157-06077	B - 14
296-14112-25	B - 6	2T4-15637-01	B - 12	3RV-21711-20	C - 5	21W-24181-00	C - 11	21W-27211-00	D - 3	90157-06124	B - 15
296-14131-00	B - 6	4BC-15641-00	B - 11	21W-21719-00	C - 5	431-24181-00	C - 6	21W-27231-00	D - 3	90159-06016	C - 5
127-14135-00	B - 6	4BC-15660-00	B - 11	3RV-2173L-60	C - 5	2X6-24183-00	C - 11	4BC-27311-00	D - 3	90159-06033	C - 4
127-14141-14	B - 6	4BC-15664-00	B - 11	21W-21751-01	C - 6	3RV-24240-B0	C - 11	21W-27411-01-33	D - 3	90167-03004	D - 2
193-14142-15	B - 6	4BC-15665-00	B - 11	21W-21766-00	C - 6	4X8-24500-02	C - 11	214-27413-00	D - 3	90170-06184	C - 15
127-14143-24	B - 6	4BC-15673-00	B - 11	5R2-21771-00	C - 6	4X8-24512-00	C - 11	214-27421-00	D - 3	90170-08366	C - 14
127-14143-25	B - 6	4BC-15676-00	B - 11	21W-22110-00-35	C - 7	3AJ-24523-00	C - 11	4X4-28100-00	C - 6	90170-10105	B - 4
127-14143-26	B - 6	4BC-15695-00	B - 11	4BC-22123-00	C - 7	3AJ-24534-00	C - 11	104-81328-20	D - 4	90175-06013	D - 3
1R0-14169-00	B - 6	56H-16110-00-30	B - 12	3R0-22151-00	C - 7	2FG-24610-00	C - 11	4BC-82310-00	D - 6	90179-06403	C - 12
307-14169-10	B - 6	4BC-16150-00	B - 12	21W-22199-00	C - 7	3RV-24731-40	C - 12	166-82370-20	D - 6	90179-07381	B - 2
127-14171-00	B - 6	122-16164-00	B - 12	3RV-22210-12	C - 7	3RV-24734-40	C - 12	4V0-82519-00	D - 5	90179-08148	D - 2

NUMERICAL INDEX

PART NO.	GRID NO.	PART NO.	GRID NO.	PART NO.	GRID NO.	PART NO.	GRID NO.	PART NO.	GRID NO.	PART NO.	GRID NO.
90179-12659	B - 12	90468-16090	B - 12	93109-15001	B - 11	95607-06100	D - 5				
90179-16190	B - 13	90480-10005	B - 4	93210-09729	B - 15	95607-10200	C - 13				
90179-25051	C - 8	90480-18290	C - 11	93210-18023	B - 3	95707-08500	C - 3				
90185-10037	C - 7	90480-21038	B - 9	93210-19123	B - 10						
90185-12134	C - 15	90501-10245	D - 3	93210-26240	B - 4	95807-06030	C - 11				
90201-06072	C - 11	90501-10602	B - 12	93210-29282	B - 4	95817-10025	C - 8				
90201-061A5	C - 15	90501-12088	B - 12	93210-41041	C - 14	95827-08120	C - 3				
90201-086P8	C - 3	90506-08122	C - 2	93210-98202	B - 12	97007-05016	D - 5				
90201-08759	C - 7	90506-10002	B - 15	93306-00416	C - 14	97007-08016	B - 5				
90201-106H5	C - 7	90506-14081	C - 13	93306-20004	C - 13						
90201-12535	B - 3	90506-15260	C - 14	93306-20009	C - 13	97007-08020	B - 8				
90201-12575	C - 2	90506-28100	D - 3	93306-20301	B - 14	97014-06035	C - 8				
90201-126A7	C - 15	90508-20023	D - 3	93306-20401	B - 14	97017-06025	B - 11				
90201-15701	B - 11	90508-29578	D - 3	93306-20517	B - 3	97027-06020	C - 2				
90202-05193	C - 11	90508-32263	C - 2	93306-30111	C - 14	97027-08020	D - 3				
90208-12015	B - 12	90560-10103	C - 13	93310-11268	B - 3	9760M-05225	B - 5				
90208-16019	B - 12	90560-12145	C - 14	93310-420F2	B - 3	9760M-05250	B - 5				
90209-10160	C - 8	90560-17146	B - 12	93315-23208	B - 15	97801-03008	C - 11				
90209-12280	B - 12	91317-06012	C - 8	93320-41202	B - 14	98502-04008	D - 4				
90209-15178	B - 14	91401-20012	C - 15	93410-20038	B - 14	98502-04010	B - 6				
90209-15179	B - 14		D - 3	93430-07012	B - 4	98502-04018	B - 6				
90209-15180	B - 14	91401-25015	D - 3	93430-09019	B - 15	98502-04025	D - 4				
90240-08084	D - 3	91401-25020	C - 7	93450-13022	B - 3	98502-05030	B - 6				
90240-10069	C - 7	92901-10100	C - 10	93451-08094	B - 12	98507-03008	B - 5				
90240-10072	C - 7	92902-04100	B - 6	93505-08030	B - 12	98507-05020	B - 4				
90249-12008	D - 3		D - 4	93603-14026	B - 4	98507-05035	B - 4				
90280-03017	B - 3	92904-06600	C - 8	93604-22050	B - 15	98507-06012	B - 10				
90282-04064	B - 12	92907-03100	B - 5	93606-14081	B - 15	98507-06020	D - 6				
90340-12005	B - 9	92907-06100	D - 6	93812-15063	B - 14	98507-06030	B - 5				
90387-07598	C - 11	92907-06600	D - 3	94125-141A6	C - 13	98507-06035	B - 9				
90387-10744	C - 13		D - 6	94130-121A7	C - 14						
90387-12412	C - 15	92907-08100	B - 8	94225-14215	C - 13	98507-06040	B - 10				
90387-20603	B - 3		C - 3	94227-12216	C - 14	98507-06045	B - 9				
90387-207G3	C - 14		D - 3	94325-14129	C - 13						
90401-10029	B - 4	92907-08600	B - 5	94330-12130	C - 14	98507-06050	B - 9				
90430-04004	B - 4		B - 8	94414-14002	C - 13	98507-06100	B - 10				
90430-10171	B - 9		C - 15	94416-12003	C - 14	98507-08010	B - 9				
90430-12227	B - 9	92907-10100	C - 8	94561-66084	C - 15	9850M-05006	B - 8				
90445-05390	B - 7	92907-10200	C - 13	94661-66001	C - 15	98802-05100	B - 6				
90445-07036	B - 7	92907-12600	D - 3	94701-00198	B - 2	99001-03600	B - 12				
90445-084J1	C - 11	93101-10001	B - 4	94703-00198	B - 2	99001-09600	D - 3				
90445-09082	C - 11	93101-12004	C - 2	95027-06020	D - 6	99001-10600	B - 15				
90460-37130	B - 5	93102-20143	B - 14	95307-06600	C - 13						
90462-14055	C - 8	93103-25098	B - 3		C - 14	99009-17400	B - 11				
90467-08003	C - 6	93103-32099	B - 3	95307-08700	C - 15	99009-20400	B - 11				
		93104-11053	B - 10		D - 3	99530-10114	B - 10				
90467-22048	B - 8	93106-17006	C - 13	95307-10600	C - 8	99530-12016	B - 9				
90468-02033	B - 4	93106-30004	C - 14	95337-12600	B - 3						