

HOW TO USE THIS MANUAL

This service manual describes the service procedures for the VT750C/CD/CD2/C3/CD3.

Follow the Maintenance Schedule (Section 3) recommendations to ensure that the vehicle is in peak operating condition and the emission levels are within the standards set.

Performing the first scheduled maintenance is very important. It compensates for the initial wear that occurs during the break-in period.

Sections 1 and 3 apply to the whole motorcycle. Section 2 illustrates procedures for removal/installation of components that may be required to perform service described in the following sections.

Section 4 through 19 describe parts of the motorcycle, grouped according to location.

Find the section you want on this page, then turn to the table of contents on the first page of the section.

Most sections start with an assembly or system illustration, service information and troubleshooting for the section.

The subsequent pages give detailed procedure.

If you don't know the source of the trouble, go to section 21 Troubleshooting.

ALL INFORMATION, ILLUSTRATIONS, DIRECTIONS AND SPECIFICATIONS INCLUDED IN THIS PUBLICATION ARE BASED ON THE LATEST PRODUCT INFORMATION AVAILABLE AT THE TIME OF APPROVAL FOR PRINTING. HONDA MOTOR CO., LTD. RESERVES THE RIGHT TO MAKE CHANGES AT ANY TIME WITHOUT NOTICE AND WITHOUT INCURRING ANY OBLIGATION WHATEVER. NO PART OF THIS PUBLICATION MAY BE REPRODUCED WITHOUT WRITTEN PERMISSION. THIS MANUAL IS WRITTEN FOR PERSONS WHO HAVE ACQUIRED BASIC KNOWLEDGE OF MAINTENANCE ON HONDA MOTORCYCLES, MOTOR SCOOTERS OR ATVS.











HONDA MOTOR CO., LTD.
SERVICE PUBLICATION OFFICE

CONTENTS

	GENERAL INFORMATION	1
	FRAME/BODY PANELS/EXHAUST SYSTEM	2
	MAINTENANCE	3
ENGINE AND DRIVE TRAIN	LUBRICATION SYSTEM	4
	FUEL SYSTEM	5
	COOLING SYSTEM	6
	ENGINE REMOVAL/INSTALLATION	7
	CLUTCH/GEARSHIFT LINKAGE	8
	ALTERNATOR/STARTER CLUTCH	9
	CYLINDER HEAD/VALVES	10
	CYLINDER/PISTON	11
	CRANKSHAFT/TRANSMISSION	11
CHASSIS	FRONT WHEEL/SUSPENSION/STEERING	11
	REAR WHEEL/BRAKE/SUSPENSION	11
	HYDRAULIC BRAKE	11
ELECTRICAL	BATTERY/CHARGING SYSTEM	11
	IGNITION SYSTEM	11
	ELECTRIC STARTER	11
	LIGHTS/METERS/SWITCHES	11
	WIRING DIAGRAM	21
	TROUBLESHOOTING	21
	INDEX	21

SYMBOLS

The symbols used throughout this manual show specific service procedures. If supplementary information is required pertaining to these symbols, it would be explained specifically in the text without the use of the symbols.

	Replace the part(s) with new one(s) before assembly.
	Use recommended engine oil, unless otherwise specified.
	Use molybdenum oil solution (mixture of the engine oil and molybdenum grease in a ratio of 1 : 1).
	Use multi-purpose grease (Lithium based multi-purpose grease NLGI #2 or equivalent).
	Use molybdenum disulfide grease (containing more than 3 % molybdenum disulfide, NLGI #2 or equivalent). Example: Molykote® BR-2 plus manufactured by Dow Corning, U.S.A. Multi-purpose M-2 manufactured by Mitsubishi Oil, Japan
	Use molybdenum disulfide paste (containing more than 40 % molybdenum disulfide, NLGI #2 or equivalent). Example: Molykote® BR-2 plus, manufactured by Dow Corning, U.S.A. Honda Moly 60 (U.S.A. only) Rocol ASP manufactured by Rocol Limited, U.K. Rocol Paste manufactured by Sumico Lubricant, Japan
	Use silicone grease.
	Apply a locking agent. Use a middle strength locking agent unless otherwise specified.
	Apply sealant.
	Use DOT 4 brake fluid. Use the recommended brake fluid unless otherwise specified.
	Use Fork or Suspension Fluid.

1. GENERAL INFORMATION

GENERAL SAFETY	1-1	TOOLS	1-17
SERVICE RULES	1-2	LUBRICATION & SEAL POINTS	1-19
MODEL IDENTIFICATION	1-3	CABLE & HARNESS ROUTING	1-22
SPECIFICATIONS	1-4	EMISSION CONTROL SYSTEMS	1-34
TORQUE VALUES	1-13	EMISSION CONTROL INFORMATION LABELS	1-36

1

GENERAL SAFETY

CARBON MONOXIDE

If the engine must be running to do some work, make sure the area is well ventilated. Never run the engine in an enclosed area.

⚠ WARNING

The exhaust contains poisonous carbon monoxide gas that can cause loss of consciousness and may lead to death.

Run the engine in an open area or with an exhaust evacuation system in an enclosed area.

GASOLINE

Work in a well ventilated area. Keep cigarettes, flames or sparks away from the work area or where gasoline is stored.

⚠ WARNING

Gasoline is extremely flammable and is explosive under certain conditions. KEEP OUT OF REACH OF CHILDREN.

HOT COMPONENTS

⚠ WARNING

Engine and exhaust system parts become very hot and remain hot for some time after the engine is run. Wear insulated gloves or wait until the engine and exhaust system have cooled before handling these parts.

USED ENGINE OIL

⚠ WARNING

Used engine oil may cause skin cancer if repeatedly left in contact with the skin for prolonged periods. Although this is unlikely unless you handle used oil on a daily basis, it is still advisable to thoroughly wash your hands with soap and water as soon as possible after handling used oil. KEEP OUT OF REACH OF CHILDREN.

BRAKE DUST

Never use an air hose or dry brush to clean the brake assemblies.

BRAKE FLUID

CAUTION:

Spilling fluid on painted, plastic or rubber parts will damage them. Place a clean shop towel over these parts whenever the system is serviced. KEEP OUT OF REACH OF CHILDREN.

GENERAL INFORMATION

COOLANT

Under some conditions, the ethylene glycol in engine coolant is combustible and its flame is not visible. If the engine ethylene glycol does ignite, you will not see any flame, but you can be burned.

▲ WARNING

- *Avoid spilling engine coolant on the exhaust system or engine parts. They may be hot enough to cause the coolant to ignite and burn without a visible flame.*
- *Coolant (ethylene glycol) can cause some skin irritation and is poisonous if swallowed, KEEP OUT OF REACH OF CHILDREN.*
- *Keep out of reach of pets. Some pets are attracted to the smell and taste of coolant and can die if they drink it.*
- *Do not remove the radiator cap when the engine is hot. The coolant is under pressure and could scald you.*

CAUTION:

Using coolant with silicate inhibitors may cause premature wear of water pump seals or blockage of radiator passages. Using tap water may cause engine damage.

If it contacts your skin, wash the affected areas immediately with soap and water. If it contacts your eyes, flush them thoroughly with fresh water and get immediate medical attention. If it is swallowed, the victim must be forced to vomit, then rinse mouth and throat with fresh water before obtaining medical attention. Because of these dangers, always keep from the reach of children. Recycle used coolant in an ecologically correct manner.

SERVICE RULES

1. Use genuine HONDA or HONDA-recommended parts and lubricants or their equivalents. Parts that don't meet HONDA's design specifications may cause damage to the motorcycle.
2. Use the special tools designed for this product to avoid damage and incorrect assembly.
3. Use only metric tools when servicing the motorcycle. Metric bolts, nuts and screws are not interchangeable with English fasteners.
4. Install new gaskets, O-rings, cotter pins, and lock plates when reassembling.
5. When tightening bolts or nuts, begin with the larger diameter or inner bolt first. Then tighten to the specified torque diagonally in incremental steps unless a particular sequence is specified.
6. Clean parts in cleaning solvent upon disassembly. Lubricate any sliding surfaces before reassembly.
7. After reassembly, check all parts for proper installation and operation.
8. Route all electrical wires as shown on pages 1-22 through 1-33, Cable and Harness Routing.

BATTERY HYDROGEN GAS & ELECTROLYTE

▲ WARNING

- *The battery gives off explosive gases; keep sparks, flames and cigarettes away. Provide adequate ventilation when charging.*
- *The battery contains sulfuric acid (electrolyte). Contact with skin or eyes may cause severe burns. Wear protective clothing and a face shield.*
 - *If electrolyte gets on your skin, flush with water.*
 - *If electrolyte gets in your eyes, flush with water for at least 15 minutes and call a physician immediately.*
- *Electrolyte is poisonous.*
 - *If swallowed, drink large quantities of water or milk and follow with milk of magnesia or vegetable oil and call a physician. KEEP OUT OF REACH OF CHILDREN.*

MODEL IDENTIFICATION

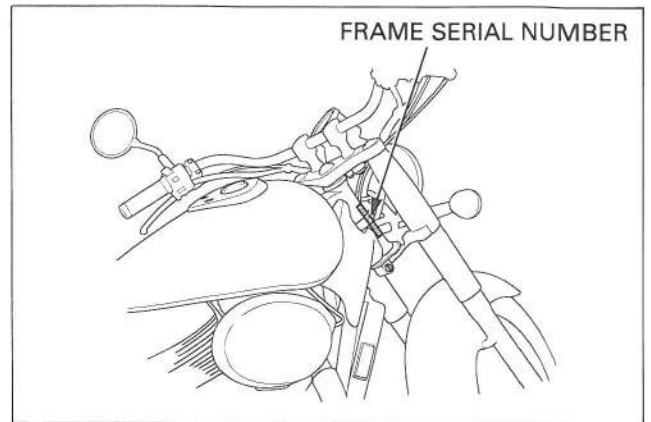
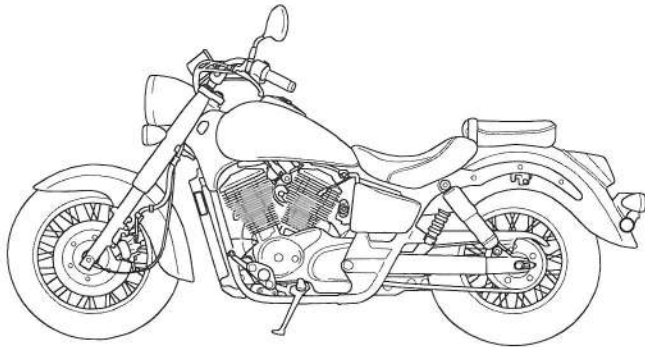

- (1) The frame serial number is stamped on the right side of the steering head.

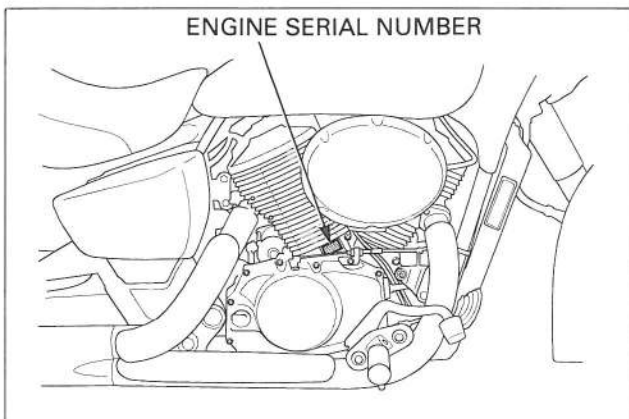

- (2) The engine serial number is stamped on the right side of the crankcase below the rear cylinder.

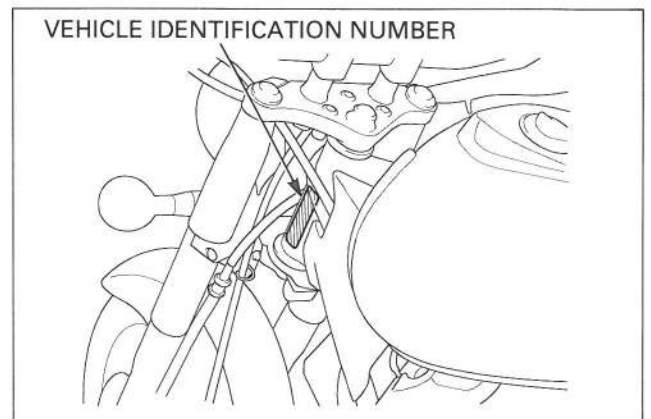

- (3) The Vehicle Identification Number (VIN) is attached on the left side of the steering head.

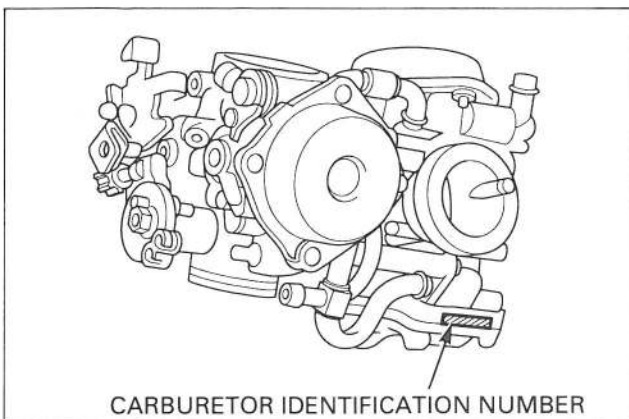

- (4) The carburetor identification numbers are stamped on the intake side of the carburetor body as shown.

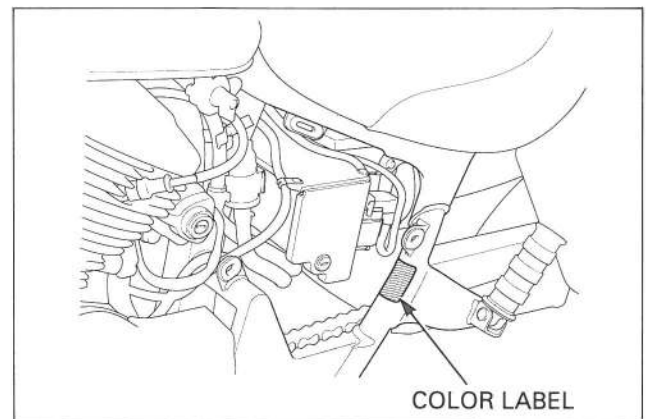

- (5) The color label is attached on the frame back of the left side cover. When ordering color-coded parts, always specify the designated color code.

GENERAL INFORMATION

SPECIFICATIONS

ITEM		SPECIFICATIONS
DIMENSIONS	Overall length Overall width Overall height VT750C : VT750CD/CD2 ('98 – 2000) : (After 2000) : VT750C3/CD3 : Wheelbase Seat height Footpeg height Ground clearance Dry weight Curb weight Maximum weight capacity	2,450 mm (96.5 in) 980 mm (38.6 in) 1,135 mm (44.7 in) 1,135 mm (44.7 in) 1,110 mm (43.7 in) 1,110 mm (43.7 in) 1,615 mm (63.6 in) 700 mm (27.6 in) 302 mm (11.9 in) 145 mm (5.7 in) 229 kg (505 lbs) 246 kg (542 lbs) 170 kg (375 lbs)
FRAME	Frame type Front suspension Front wheel travel Rear suspension Rear wheel travel Rear damper Front tire size Rear tire size Tire brand Bridgestone Dunlop Front brake Rear brake Caster angle Trail length Fuel tank capacity Fuel tank reserve capacity	Double cradle Telescopic fork 140 mm (5.5 in) Swingarm 90 mm (3.5 in) Nitrogen gas filled damper 120/90-17 64S 170/80-15 M/C 77S Front: G701/Rear: G702 Front: D404F/Rear: D404 Hydraulic single disc brake Internal expanding shoe 33° 50' 157 mm (6.2 in) 14.0 liter (3.70 US gal, 3.08 Imp gal) 3.6 liter (0.95 US gal, 0.79 Imp gal)
ENGINE	Bore and stroke Displacement Compression ratio Valve train Intake valve opens closes Exhaust valve opens closes Lubrication system Oil pump type Cooling system Air filtration Crankshaft type Engine dry weight Firing order Cylinder arrangement Cylinder number	79.0 X 76.0 mm (3.11 X 2.99 in) 745 cm ³ (45.4 cu-in) 9.0 : 1 Silent, multi-link chain drive and OHC with rocker arm 0° BTDC ┌───┐ at 1 mm (0.04 in) lift ├───┤ 20° ABDC ├───┤ ├───┤ 30° BBDC ├───┤ ├───┤ 0° ATDC └───┘ Forced pressure and wet sump Trochoid Liquid cooled Paper filter Unit type, two main journals 68.6 kg (151 lbs) Front – 308° – Rear – 412° – Front Two cylinders, 52° V transverse Front: #2, Rear: #1
CARBURETOR	Carburetor type Throttle bore	CV (Constant Velocity) dual carburetor with fuel pump 34 mm (1.3 in)

GENERAL (Cont'd)

ITEM		SPECIFICATIONS
DRIVE TRAIN	Clutch system Clutch operation system Transmission Primary reduction Final reduction Gear ratio 1st 2nd 3rd 4th 5th Gearshift pattern	Multi-plate, wet Mechanical type Constant mesh, 5-speed 1.667 (65/39) 2.412 (41/17) 3.167 (38/12) 2.000 (34/17) 1.500 (30/20) 1.174 (27/23) 1.042 (25/24) Left foot operated return system, 1 - N - 2 - 3 - 4 - 5
ELECTRICAL	Ignition system Starting system Charging system Regulator/rectifier Lighting system	Full transistor digital ignition Electric starter motor Triple phase output alternator SCR shorted/triple phase, full wave rectification Battery

GENERAL INFORMATION

Unit: mm (in)

LUBRICATION SYSTEM		STANDARD	SERVICE LIMIT
ITEM			
Engine oil capacity	at draining	2.2 liter (2.32 US qt, 1.94 Imp qt)	—
	at disassembly	2.9 liter (3.06 US qt, 2.55 Imp qt)	—
	at oil filter change	2.4 liter (2.54 US qt, 2.11 Imp qt)	—
Recommended engine oil		HONDA GN4 4-stroke oil or equivalent motor oil API service classification SF or SG Viscosity: SAE 10W-40	—
Oil pressure at oil pressure switch		530 kPa (5.4 kgf/cm ² , 77 psi) at 5,500 rpm (80°C/176°F)	—
Oil pump rotor	Tip clearance	0.15 (0.006)	0.20 (0.008)
	Body clearance	0.15 – 0.22 (0.006 – 0.009)	0.35 (0.014)
	Side clearance	0.02 – 0.07 (0.001 – 0.003)	0.10 (0.004)

FUEL SYSTEM		SPECIFICATIONS	
ITEM			
Carburetor identification number	49 state type	'98	VDFFG
		After '98	VDFFJ
	California type	'98	VDFEB
		After '98	VDFEC
	Canada type	'98 VT750C/CD/CD2	VDFFG
'98 VT750C3/CD3 After '98		VDFFJ	
Main jet	Front	#105	
	Rear	#110	
Slow jet		#40	
Pilot screw	Initial/final opening	See page 5-22	
Float level		7.0 mm (0.28 in)	
Base carburetor (for synchronization)		Rear cylinder (#1)	
Idle speed		1,000 ± 100 rpm	
Carburetor vacuum difference		27 kPa (20 mm Hg, 0.7 in Hg)	
PAIR control valve specified vacuum		325 mm Hg (12.8 in Hg)	
Throttle grip free play		2 – 6 mm (1/12 – 1/4 in)	
Fuel pump flow capacity		Minimum 900 cm ³ (30.4 US oz, 31.7 Imp oz) per minute at 12 V	

COOLING SYSTEM		SPECIFICATIONS
ITEM		
Coolant capacity	Radiator and engine	1.75 liter (1.85 US qt, 1.54 Imp qt)
	Reserve tank	0.4 liter (0.42 US qt, 0.35 Imp qt)
Radiator cap relief pressure		108 – 137 kPa (1.1 – 1.4 kgf/cm ² , 16 – 20 psi)
Thermostat	Begins to open	80 – 84 °C (176 – 183 °F)
	Fully open	95 °C (203 °F)
	Valve lift	8 mm (0.3 in) minimum
Recommended antifreeze		Pro Honda HP Coolant or an equivalent high quality ethylene glycol antifreeze containing corrosion protection inhibitors
Standard coolant concentration		50 % mixture with soft water

GENERAL INFORMATION

CLUTCH SYSTEM

Unit: mm (in)

ITEM		STANDARD	SERVICE LIMIT
Clutch lever free play		10 – 20 (3/8 - 3/4)	—
Clutch spring free length		45.5 (1.79)	43.9 (1.73)
Clutch disc thickness	A	2.62 – 2.78 (0.103 – 0.107)	2.3 (0.09)
	B	2.92 – 3.08 (0.115 – 0.121)	2.6 (0.10)
Clutch plate warpage		—	0.30 (0.012)
Clutch outer guide	I.D.	21.991 – 22.016 (0.8658 – 0.8668)	22.03 (0.867)
	O.D.	29.994 – 30.007 (1.1809 – 1.1814)	29.98 (1.180)
Oil pump drive sprocket I.D.		30.025 – 30.145 (1.1821 – 1.1868)	30.15 (1.187)
Mainshaft O.D. at clutch outer guide		21.967 – 21.980 (0.8648 – 0.8654)	21.95 (0.864)

ALTERNATOR/STARTER CLUTCH

Unit: mm (in)

ITEM		STANDARD	SERVICE LIMIT
Starter driven gear	I.D.	40.000 – 40.021 (1.5748 – 1.5756)	40.10 (1.579)
	O.D.	57.749 – 57.768 (2.2736 – 2.2743)	57.73 (2.273)
Starter clutch outer I.D.		74.414 – 74.440 (2.9297 – 2.9307)	74.46 (2.931)

CYLINDER HEAD/VALVES

Unit: mm (in)

ITEM			STANDARD	SERVICE LIMIT
Cylinder compression			1,275 ± 98 kPa (13.0 ± 1.0 kgf/cm ² , 185 ± 14 psi) at 400 rpm	—
Cylinder head warpage			—	0.10 (0.004)
Valve, valve guide	Valve clearance	IN	0.13 – 0.17 (0.005 – 0.007)	—
		EX	0.18 – 0.22 (0.007 – 0.009)	—
	Valve stem O.D.	IN	5.475 – 5.490 (0.2156 – 0.2161)	5.45 (0.215)
		EX	6.555 – 6.570 (0.2580 – 0.2587)	6.55 (0.258)
	Valve guide I.D.	IN	5.500 – 5.512 (0.2165 – 0.2170)	5.56 (0.219)
		EX	6.600 – 6.615 (0.2598 – 0.2604)	6.65 (0.262)
	Stem-to-guide clearance	IN	0.010 – 0.037 (0.0004 – 0.0015)	0.10 (0.004)
		EX	0.030 – 0.060 (0.0012 – 0.0024)	0.11 (0.004)
	Valve guide projection above cylinder head	IN	19.5 (0.77)	—
		EX	18.0 (0.71)	—
Valve seat width		IN/EX	0.90 – 1.10 (0.035 – 0.043)	1.5 (0.06)
Valve spring free length			IN	42.14 (1.659)
			EX	42.83 (1.686)
Camshaft	Cam lobe height	IN	38.381 (1.5111)	38.10 (1.500)
		EX	38.407 (1.5121)	38.20 (1.504)
	Journal O.D.		21.959 – 21.980 (0.8645 – 0.8654)	21.90 (0.862)
	Runout		0.030 (0.012)	0.05 (0.002)
	Oil clearance		0.050 – 0.111 (0.0020 – 0.0044)	0.13 (0.005)
Identification marks			"F": Front, "R": Rear	—
Rocker arm I.D.		IN/EX	12.000 – 12.018 (0.4724 – 0.4731)	12.05 (0.474)
Rocker arm shaft O.D.		IN/EX	11.966 – 11.984 (0.4711 – 0.4718)	11.83 (0.466)
Rocker arm-to-rocker arm shaft clearance			0.016 – 0.052 (0.0006 – 0.0020)	0.07 (0.003)

GENERAL INFORMATION

CYLINDER/PISTON			Unit: mm (in)	
ITEM			SERVICE LIMIT	
Cylinder	I.D.		79.000 – 79.015 (3.1102 – 3.1108)	
	Out of round		———	
	Taper		———	
	Warpage		———	
Piston, piston rings	Piston mark direction		"IN" mark facing toward the intake side	
	Piston O.D.		78.97 – 78.99 (3.109 – 3.110)	
	Piston O.D. measurement point		7 – 17 mm (0.3 – 0.7 in) from bottom of skirt	
	Piston pin bore I.D.		18.002 – 18.008 (0.7087 – 0.7090)	
	Piston pin O.D.		17.994 – 18.000 (0.7084 – 0.7087)	
	Piston-to-piston pin clearance		0.002 – 0.014 (0.0001 – 0.0006)	
	Piston ring-to-ring groove clearance	Top	0.025 – 0.055 (0.0010 – 0.0022)	
		Second	0.015 – 0.045 (0.0006 – 0.0018)	
	Piston ring end gap	Top	'98 – 2000	0.20 – 0.35 (0.008 – 0.014)
			After 2000	0.15 – 0.25 (0.006 – 0.010)
		Second	'98 – 2000	0.35 – 0.50 (0.014 – 0.020)
			After 2000	0.25 – 0.40 (0.010 – 0.016)
		Oil (side rail)		0.20 – 0.80 (0.008 – 0.031)
	Piston ring mark	Top	"R" mark	
Second		"RN" mark		
Cylinder-to-piston clearance		0.010 – 0.045 (0.0004 – 0.0018)		
Connecting rod small end I.D.		18.016 – 18.034 (0.7093 – 0.7100)		
Connecting rod-to-piston pin clearance		0.016 – 0.040 (0.0006 – 0.0016)		

Unit: mm (in)

CRANKSHAFT/TRANSMISSION			STANDARD	SERVICE LIMIT
ITEM				
Crankshaft	Side clearance		0.05 – 0.20 (0.002 – 0.008)	0.30 (0.012)
	Runout		—	0.03 (0.001)
	Crank pin oil clearance		0.028 – 0.052 (0.0011 – 0.0020)	0.07 (0.003)
	Main journal oil clearance		0.030 – 0.046 (0.0012 – 0.0018)	0.07 (0.003)
Transmission	Gear I.D.	M3, M5	28.000 – 28.021 (1.1024 – 1.1032)	28.04 (1.104)
		C1, C2, C4	31.000 – 31.025 (1.2204 – 1.2215)	31.05 (1.222)
	Bushing O.D.	M3, M5	27.959 – 27.980 (1.1007 – 1.1016)	27.94 (1.100)
		C1, C2, C4	30.950 – 30.975 (1.2185 – 1.2195)	30.93 (1.218)
	Bushing I.D.	M3	25.000 – 25.021 (0.9843 – 0.9851)	25.04 (0.986)
		C2	27.995 – 28.016 (1.1021 – 1.1030)	28.04 (1.104)
	Gear-to-bushing clearance	M3, M5	0.020 – 0.062 (0.0008 – 0.0024)	0.10 (0.004)
		C1, C2, C4	0.025 – 0.075 (0.0010 – 0.0030)	0.11 (0.004)
	Mainshaft O.D.	M3 bushing	24.972 – 24.993 (0.9831 – 0.9840)	24.95 (0.982)
		Case journal A	19.980 – 19.993 (0.7866 – 0.7871)	19.96 (0.786)
		Case journal B	21.967 – 21.980 (0.8648 – 0.8654)	21.94 (0.864)
	Countershaft O.D.	C2 bushing	27.967 – 27.980 (1.1011 – 1.1016)	27.95 (1.100)
		Case journal A	27.972 – 27.990 (1.1013 – 1.1020)	27.95 (1.100)
		Case journal B	19.980 – 19.993 (0.7866 – 0.7871)	19.96 (0.786)
	Bushing-to-shaft clearance	M3	0.007 – 0.049 (0.0003 – 0.0019)	0.08 (0.003)
C2		0.015 – 0.049 (0.0006 – 0.0019)	0.08 (0.003)	
Shift fork, fork shaft	Fork	I.D.	13.000 – 13.021 (0.5118 – 0.5126)	13.04 (0.513)
		Claw thickness	5.93 – 6.00 (0.233 – 0.236)	5.6 (0.22)
	Fork shaft O.D.		12.966 – 12.984 (0.5105 – 0.5112)	12.90 (0.508)
Shift drum O.D. (at left side journal)			11.966 – 11.984 (0.4711 – 0.4718)	11.94 (0.470)

GENERAL INFORMATION

FRONT WHEEL/SUSPENSION/STEERING			Unit: mm (in)
ITEM		STANDARD	SERVICE LIMIT
Minimum tire tread depth		—	1.5 (0.06)
Cold tire pressure	Up to 90 kg (200 lb) load	200 kPa (2.00 kgf/cm ² , 29 psi)	—
	Up to maximum weight capacity	200 kPa (2.00 kgf/cm ² , 29 psi)	—
Axle runout		—	0.20 (0.008)
Wheel rim runout	Radial	—	2.0 (0.08)
	Axial	—	2.0 (0.08)
Wheel hub-to-rim distance		(page 13-17)	—
Wheel balance weight		—	60 g (2.1 oz)
Fork	Spring free length	303.4 (11.94)	297.3 (11.70)
	Tube runout	—	0.20 (0.008)
	Recommended fork fluid	Pro-Honda Suspension Fluid SS-8	—
	Oil level	108 (4.3)	—
	Oil capacity	514 ± 2.5 cm ³ (17.4 ± 0.08 US oz, 18.0 ± 0.09 Imp oz)	—
Steering head bearing preload		0.43 – 1.04 kgf (0.95 – 2.30 lbf)	—

REAR WHEEL/BRAKE/SUSPENSION			Unit: mm (in)
ITEM		STANDARD	SERVICE LIMIT
Minimum tire tread depth		—	2.0 (0.08)
Cold tire pressure	Up to 90 kg (200 lb) load	200 kPa (2.00 kgf/cm ² , 29 psi)	—
	Up to maximum weight capacity	250 kPa (2.50 kgf/cm ² , 36 psi)	—
Axle runout		—	0.20 (0.008)
Wheel rim runout	Radial	—	2.0 (0.08)
	Axial	—	2.0 (0.08)
Wheel hub-to-rim distance		(page 14-8)	—
Wheel balance weight		—	70 g (2.5 oz)
Drive chain slack		15 – 25 (3/5 – 1)	40 (1-3/5)
Drive chain link		122L	—
Drive chain size	DID	525 V8	—
	RK	525 SMOZ5	—
Rear brake	Drum I.D.	180.0 – 180.3 (7.09 – 7.10)	181 (7.13)
	Lining thickness	5 (0.2)	2 (0.1)
Brake pedal height		50 mm (2.0 in) above the top of the footpeg	—
Brake pedal free play		20 – 30 (3/4 – 1-1/4)	—
Shock absorber spring preload adjuster setting		2nd position	—

GENERAL INFORMATION

Unit: mm (in)

HYDRAULIC BRAKE			
ITEM		STANDARD	SERVICE LIMIT
Specified brake fluid		DOT 4	—
Brake pad wear indicator		—	To groove
Brake disc thickness		5.8 – 6.2 (0.23 – 0.24)	5 (0.2)
Brake disc runout		—	0.30 (0.012)
Master cylinder I.D.		11.000 – 11.043 (0.4331 – 0.4348)	11.05 (0.435)
Master piston O.D.		10.957 – 10.984 (0.4314 – 0.4324)	10.945 (0.4309)
Caliper cylinder I.D.		27.000 – 27.050 (1.0630 – 1.0650)	27.06 (1.065)
Caliper piston O.D.		26.935 – 26.968 (1.0604 – 1.0617)	26.93 (1.060)

BATTERY/CHARGING SYSTEM				
ITEM		SPECIFICATIONS		
Battery	Capacity	12 V – 14 Ah		
	Current leakage	1.0 mA max		
	Voltage (20°C/68°F)	Fully charged	13.0 – 13.2 V	
		Needs charging	Below 12.3 V	
	Charging current	Normal	1.4 A/5 – 10 h	
Quick		6.0 A/1 h max		
Alternator	Capacity	345 W/5,000 rpm		
	Charging coil resistance (20°C/68°F)	0.1 – 0.3 Ω		
Regulator/rectifier regulated voltage		14 – 15 V/4,000 rpm		

IGNITION SYSTEM			
ITEM		SPECIFICATIONS	
Spark plug		NGK	DENSO
	Standard	DPR8EA 9	X24EPR-U9
	For cold climate (below 5°C/41°F)	DPR7EA 9	X22EPR-U9
	For extended high speed riding	DPR9EA 9	X27EPR-U9
Spark plug gap		0.80 – 0.90 mm (0.031 – 0.035 in)	
Ignition coil primary peak voltage		100 V minimum	
Ignition pulse generator peak voltage		0.7 V minimum	
Ignition timing "F" mark		8° BTDC at 1,000 rpm	
Advance	Start	3,000 ± 200 rpm	
	Stop	5,500 ± 200 rpm	
Full advance		24.5° BTDC at 5,500 rpm	

GENERAL INFORMATION

Unit: mm (in)

ELECTRIC STARTER

ITEM	STANDARD	SERVICE LIMIT
Starter motor brush length	12.5 (0.49)	6.5 (0.26)

LIGHTS/METERS/SWITCHES

ITEM		SPECIFICATIONS	
Bulbs	Headlight (High/Low beam)	12V – 60/55 W	
	Brake/tail light	12V – 32/3 CP	
	Front turn signal/running light	12V – 21/5 W X 2	
	Rear turn signal light	12V – 21 W X 2	
	License light	12V – 4CP	
	Speedometer light	VT750C	12V – 3.4 W
		VT750CD/CD2 ('98 – 2000)	
		VT750CD/CD2 (After 2000)	12V – 1.7 W
		VT750C3/CD3	
	Turn signal indicator	12V – 3.4 W	
	High beam indicator	12V – 3.4 W	
	Neutral indicator	12V – 3.4 W	
	Side stand indicator	VT750CD/CD2 (After 2000) VT750C3/CD3	12V – 3.4 W
Oil indicator	VT750CD/CD2 (After 2000) VT750C3/CD3	12V – 3.4 W	
Temp indicator	VT750CD/CD2 (After 2000) VT750C3/CD3	12V – 3.4 W	
Fuse	Main fuse	30 A	
	Sub fuse	10 A X 4, 15 A X 1	
Fan motor switch	Starts to close (ON)	98 – 102 °C (208 – 216 °F)	
	Starts to open (OFF)	93 – 97 °C (199 – 207 °F)	
Coolant temperature switch	Starts to close (ON)	112 – 118 °C (259 – 270 °F)	
	Starts to open (OFF)	Below 108 °C (252 °F)	

TORQUE VALUES

FASTENER TYPE	TORQUE N•m (kgf•m, lbf•ft)	FASTENER TYPE	TORQUE N•m (kgf•m, lbf•ft)
5 mm hex bolt and nut	5 (0.5, 3.6)	5 mm screw	4 (0.4, 2.9)
6 mm hex bolt and nut	10 (1.0, 7)	6 mm screw	9 (0.9, 6.5)
8 mm hex bolt and nut	22 (2.2, 16)	6 mm flange bolt (8 mm head)	9 (0.9, 6.5)
10 mm hex bolt and nut	34 (3.5, 25)	6 mm flange bolt (10 mm head) and nut	12 (1.2, 9)
12 mm hex bolt and nut	54 (5.5, 40)	8 mm flange bolt and nut	26 (2.7, 20)
		10 mm flange bolt and nut	39 (4.0, 29)

- Torque specifications listed below are for important fasteners.
- Others should be tightened to standard torque values listed above.

- NOTES:
1. Apply sealant to the threads.
 2. Apply a locking agent to the threads.
 3. Apply grease to the threads.
 4. Stake.
 5. Apply oil to the threads and flange surface.
 6. Apply oil to the threads and O-ring.
 7. U-nut.
 8. ALOC bolt: replace with a new one.
 9. Left hand threads
 10. CT bolt
 11. CT bolt (one-side only)

ENGINE

ITEM	Q'TY	THREAD DIA. (mm)	TORQUE N•m (kgf•m, lbf•ft)	REMARKS
MAINTENANCE:				
Spark plug	4	12	14 (1.4, 10)	
Crankshaft hole cap	1	22	15 (1.5, 11)	NOTE 3
Timing hole cap	1	30	15 (1.5, 11)	NOTE 3
Valve adjusting screw lock nut	6	7	23 (2.3, 17)	NOTE 5
Oil drain bolt	1	14	30 (3.1, 22)	
Oil filter cartridge	1	20	10 (1.0, 7)	NOTE 6
Vacuum plug	2	5	3 (0.3, 2.2)	
LUBRICATION SYSTEM:				
Oil pressure switch	1	PT1/8	12 (1.2, 9)	NOTE 1
Oil pressure switch cord terminal screw	1	4	2 (0.2, 1.4)	
Oil pump cover bolt	3	6	13 (1.3, 9)	NOTE 10
COOLING SYSTEM:				
Water pump cover bolt	3	6	13 (1.3, 9)	NOTE 10
CLUTCH/GEARSHIFT LINKAGE:				
Clutch lifter plate bolt	4	6	12 (1.2, 9)	
Clutch center lock nut	1	18	128 (13.0, 94)	NOTE 4, 5
Primary drive gear bolt	1	12	88 (9.0, 65)	NOTE 5
Gearshift return spring pin	1	8	23 (2.3, 17)	
Oil pump driven sprocket bolt	1	6	15 (1.5, 11)	NOTE 2
ENGINE MOUNTING:				
Left rear cover bolt	1	6	12 (1.2, 9)	
Drive sprocket bolt	2	6	10 (1.0, 7)	
Drive chain guide plate bolt	2	6	12 (1.2, 9)	NOTE 11

GENERAL INFORMATION

ENGINE (Cont'd)				
ITEM	Q'TY	THREAD DIA. (mm)	TORQUE N·m (kgf·m, lbf·ft)	REMARKS
ALTERNATOR/STARTER CLUTCH:				
Flywheel bolt	1	12	127 (13.0, 94)	NOTE 5, 9
Stator mounting socket bolt	4	6	12 (1.2, 9)	NOTE 2
Starter one-way clutch housing bolt	6	8	29 (3.0, 22)	NOTE 2
Stator wire holder socket bolt	1	6	12 (1.2, 9)	NOTE 2
Ignition pulse generator bolt	2	6	12 (1.2, 9)	NOTE 2
CYLINDER HEAD/VALVES:				
Air cleaner housing stay mounting bolt	1	6	13 (1.3, 9)	NOTE 10
EVAP air injection reed valve cover bolt	2	5	5 (0.5, 3.6)	NOTE 10
Cylinder head cover bolt	4	6	10 (1.0, 7)	
Cam sprocket bolt	4	7	23 (2.3, 17)	NOTE 2
Camshaft end holder bolt	4	6	10 (1.0, 7)	
Camshaft holder 8 mm bolt	6	8	23 (2.3, 17)	
8 mm nut	4	8	23 (2.3, 17)	
Cam chain tensioner mounting bolt	4	6	10 (1.0, 7)	
Cylinder head 6 mm bolt	2	6	12 (1.2, 9)	NOTE 5
8 mm bolt	4	8	23 (2.3, 17)	NOTE 5
8 mm nut	2	8	23 (2.3, 17)	NOTE 5
10 mm nut	8	10	47 (4.8, 35)	NOTE 5
Cylinder head fin socket bolt	15	6	10 (1.0, 7)	
Crankcase breather case cover bolt	3	6	12 (1.2, 9)	
CRANKCASE/CRANKSHAFT/TRANSMISSION:				
Crankcase 8 mm bolt	13	8	23 (2.3, 17)	
Connecting rod bearing cap nut	8	8	33 (3.4, 25)	NOTE 5
Neutral switch	1	10	12 (1.2, 9)	
ELECTRIC STARTER:				
Starter motor cable nut	1	6	10 (1.0, 7)	

FRAME				
ITEM	Q'TY	THREAD DIA. (mm)	TORQUE N•m (kgf•m, lbf•ft)	REMARKS
FRAME/BODY PANELS/EXHAUST SYSTEM:				
Exhaust pipe joint nut	4	8	25 (2.5, 18)	
Muffler bracket nut	2	8	26 (2.7, 20)	
Muffler mounting bolt	2	8	26 (2.7, 20)	
Front seat bolt	1	8	26 (2.7, 20)	
Rear seat bolt	1	6	9 (0.9, 6.5)	
Rear fender 8 mm bolt	6	8	26 (2.7, 20)	
Grab rail 10 mm bolt	2	10	64 (6.5, 47)	
24 mm nut	1	14	88 (9.0, 65)	
14 mm bolt	1	14	108 (11.0, 80)	
Fuel tank bolt	1	8	19 (1.9, 14)	
Fuel valve	1	22	34 (3.5, 25)	
Battery box bolt	1	6	10 (1.0, 7)	
Tool box cover screw	4	4	2 (0.2, 1.4)	
MAINTENANCE:				
Air cleaner housing cover bolt	6	6	2 (0.2, 1.4)	
Side stand assembly	2	10	34 (3.5, 25)	
Side stand pivot bolt	1	10	10 (1.0, 7)	
lock nut	1	10	29 (3.0, 22)	
Brake pedal stopper lock nut	1	6	10 (1.0, 7)	
Spoke nipple	104	4	4 (0.4, 2.9)	
COOLING SYSTEM:				
Radiator mounting bolt	1	6	2 (0.2, 1.4)	
Radiator coolant drain bolt	2	6	13 (1.3, 9)	
Fan motor bolt	3	5	3 (0.3, 2.2)	
Cooling fan nut	1	5	3 (0.3, 2.2)	
Radiator filler bolt	2	6	9 (0.9, 6.5)	
Thermostat housing cover bolt	2	6	9 (0.9, 6.5)	
Fan motor switch	1	PT 1/8	8 (0.8, 5.8)	NOTE 1
Water pump cover bolt	2	6	13 (1.3, 9)	
ENGINE MOUNTING:				
Front engine mounting bolt	2	10	54 (5.5, 40)	
Rear engine mounting bolt	1	10	54 (5.5, 40)	
Front engine bracket bolt	2	8	26 (2.7, 20)	
Rear engine bracket bolt	2	8	26 (2.7, 20)	
Gearshift arm pinch bolt	1	6	12 (1.2, 9)	
CLUTCH GEARSHIFT LINKAGE:				
Footpeg set arm bolt	4	8	26 (2.7, 20)	
Gearshift pedal pivot bolt	1	10	34 (3.5, 25)	
FRONT WHEEL/SUSPENSION/STEERING :				
Steering stem nut	1	24	103 (10.5, 76)	See page 13-40
Top thread A	1	26	—	
Top thread B	1	26	—	
Top bridge pinch bolt	2	8	26 (2.7, 20)	
Bottom bridge pinch bolt	2	10	49 (5.0, 36)	
Handlebar upper holder bolt	4	8	23 (2.3, 17)	
Handlebar lower holder nut	2	8	26 (2.7, 20)	
Handlebar switch screw	4	5	3 (0.3, 2.2)	
Clutch lever holder bolt	2	6	12 (1.2, 9)	
Front axle	1	14	59 (6.0, 43)	
Front axle pinch bolt	2	8	22 (2.2, 16)	
Front brake disc bolt	6	8	42 (4.3, 31)	NOTE 8
Fork cap	2	38	22 (2.2, 16)	
Fork socket bolt	2	8	29 (3.0, 22)	NOTE 2

GENERAL INFORMATION

FRAME (Cont'd)				
ITEM	Q'TY	THREAD DIA. (mm)	TORQUE N•m (kgf•m, lbf•ft)	REMARKS
REAR WHEEL/SUSPENSION:				
Rear axle nut	1	18	93 (9.5, 69)	NOTE 7
Driven sprocket nut	5	12	88 (9.0, 65)	NOTE 7
Rear shock absorber mounting bolt	4	8	26 (2.7, 20)	
Swingarm pivot nut	1	14	88 (9.0, 65)	NOTE 7
Swingarm pivot adjusting bolt	1	26	25 (2.5, 18)	
Swingarm pivot lock nut	1	26	64 (6.5, 47)	
Drive chain slider screw	2	5	3 (0.3, 2.2)	
Brake pedal pivot bolt	1	10	34 (3.5, 25)	
Rear brake stopper arm bolt	2	8	20 (2.0, 14)	
Rear brake arm bolt	1	8	29 (3.0, 22)	
Rear brake middle rod joint bolt	1	10	34 (3.5, 25)	
HYDRAULIC BRAKE:				
Brake caliper mounting bolt	2	8	30 (3.1, 22)	NOTE 6
Caliper pin bolt	1	8	26 (2.7, 20)	
Bracket pin bolt	1	8	13 (1.3, 9)	
Pad pin	1	10	18 (1.8, 13)	
Pad pin plug	1	10	3 (0.3, 2.2)	
Brake caliper bleeder	1	8	6 (0.6, 4.3)	
Brake lever pivot bolt	1	6	1 (0.1, 0.7)	
Brake lever pivot nut	1	6	6 (0.6, 4.3)	
Master cylinder holder bolt	2	6	12 (1.2, 9)	
Master cylinder cover screw	2	4	2 (0.2, 1.4)	
Front brake light switch screw	1	4	1 (0.1, 0.7)	
Brake hose oil bolt	2	10	34 (3.5, 25)	
BATTERY/CHARGING SYSTEM:				
Battery box cover screw	3	6	10 (1.0, 7)	
LIGHTS/METERS/SWITCHES:				
Side stand switch mounting bolt	1	6	10 (1.0, 7)	NOTE 8
Thermosensor	1	PT 1/8	12 (1.2, 9)	NOTE 1

TOOLS

- NOTES: 1. Alternative tool.
 2. Newly provided tool.
 3. Equivalent commercially available in U.S.A.
 4. Not available in U.S.A.



DESCRIPTION	TOOL NUMBER	REMARKS	REF. SEC.	
Carburetor float level gauge	07401 - 0010000		5	
Oil pressure gauge	07506 - 3000000	NOTE 3	4	
Vacuum gauge attachment	07510 - 3000200	NOTE 1: 07LMJ-001000A (U.S.A. only)	3	
Oil pressure gauge attachment	07510 - 4220100	NOTE 3	4	
Gear holder	07724 - 0010100		8	
Flywheel holder	07725 - 0040000	NOTE 3	9	
Rotor puller	07733 - 0020001	NOTE 1: 07933-3290001	9	
Valve guide remover, 5.5 mm	07742 - 0010100		10	
Valve guide remover, 6.6 mm	07742 - 0010200		10	
Valve guide driver	07743 - 0020000	NOTE 4	10	
Valve guide driver attachment (IN)	07743 - MF50100		10	
(EX)	07743 - MF50200		10	
Attachment, 32 X 35 mm	07746 - 0010100		14	
Attachment, 37 X 40 mm	07746 - 0010200		8, 14	
Attachment, 42 X 47 mm	07746 - 0010300		12, 13, 14	
Attachment, 52 X 55 mm	07746 - 0010400		12, 13	
Attachment	07746 - 0030300			
Pilot, 12 mm	07746 - 0040200		8	
Pilot, 15 mm	07746 - 0040300		14	
Pilot, 20 mm	07746 - 0040500		12, 13, 14	
Pilot, 25 mm	07746 - 0040600		12	
Pilot, 30 mm	07746 - 0040700		8	
Pilot, 22 mm	07746 - 0041000		12, 14	
Bearing remover shaft	07746 - 0050100		13, 14	
Bearing remover head, 17 mm	07746 - 0050500		14	
Bearing remover head, 20 mm	07746 - 0050600		13	
Attachment, 28 X 30 mm	07746 - 1870100		13, 14	
Driver	07749 - 0010000		12, 13, 14	
Valve spring compressor	07757 - 0010000		10	
Valve seat cutter			10	
Seat cutter, 27.5 mm (45° IN)	07780 - 0010200	NOTE 3		
Seat cutter, 35 mm (45° EX)	07780 - 0010400			
Flat cutter, 28 mm (32° IN)	07780 - 0012100			
Flat cutter, 35 mm (32° EX)	07780 - 0012300			
Interior cutter, 30 mm (60° IN)	07780 - 0014000			
Interior cutter, 37.5 mm (60° EX)	07780 - 0014100			
Cutter holder, 5.5 mm (IN)	07781 - 0010101			
Cutter holder, 6.6 mm (EX)	07781 - 0010202			
Valve adjusting wrench	07908 - KE90000		NOTE 1: 07908-KE90100 (U.S.A. only)	3
Snap ring pliers	07914 - 3230001			2, 14, 15
Steering stem socket	07916 - 3710101	NOTE 1: 07916-3710100	13	
Bearing remover set	07936 - 3710001	NOTE 4	12	
- Remover weight	07741 - 0010201	NOTE 1: 07936-371020A (U.S.A. only) or 07936-3710200		
- Remover handle	07936 - 3710100			
- Bearing remover set	07936 - 3710600			
Attachment, 28 X 30 mm	07946 - 1870100		8	
Bearing race remover	07946 - 3710500		13	
Driver shaft	07946 - MJ00100	NOTE 4	14	
Attachment	07946 - MJ00200		14	
Slider weight	07947 - KA50100		13	
Driver attachment set	07947 - KF00100		13	

GENERAL INFORMATION

DESCRIPTION	TOOL NUMBER	REMARKS	REF. SEC.
Driver shaft	07949 - 3710001		14
Ball race remover	07953 - MJ10000		13
- Driver attachment	07953 - MJ10100		
- Driver handle	07953 - MJ10200		
Valve guide reamer, 5.510 mm (IN)	07984 - 2000001	NOTE 1: 07984-200000D (U.S.A. only)	10
Valve guide reamer, 6.612 mm (EX)	07984 - ZE20001	NOTE 1: 07984-ZE2000D (U.S.A. only)	10
Swingarm pivot lock nut wrench	07GMA - KT70200	NOTE 4	14
Oil filter wrench	07HAA - PJ70100		3
Peak voltage adapter	07HGJ - 0020100		17
Drive chain tool set	07HMH - MR10103	NOTE 1: 07HMH-MR7010B (U.S.A. only)	3
Spoke wrench	07JMA - MR60100	NOTE 3	3, 13, 14
Clutch center holder	07JMB - MN50301	NOTE 2 NOTE 1: 07HGB-001010B 07HGB-001010A and 07HGB-001020B or 07HGB-001020A (U.S.A. only)	8
Pilot screw wrench	07KMA - MS60101		5

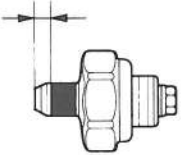
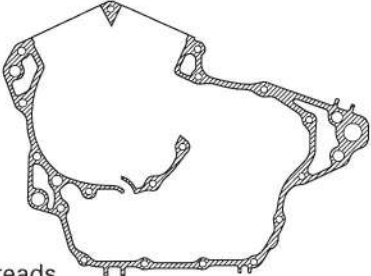
LUBRICATION & SEAL POINTS

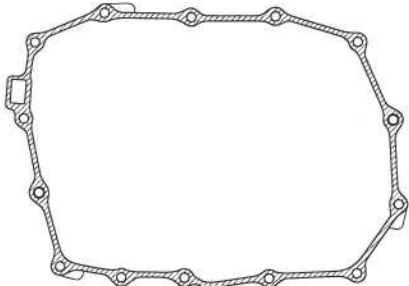
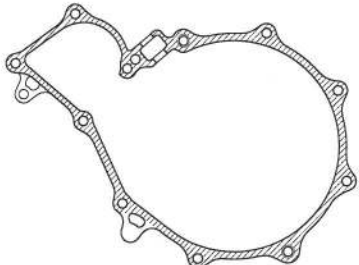
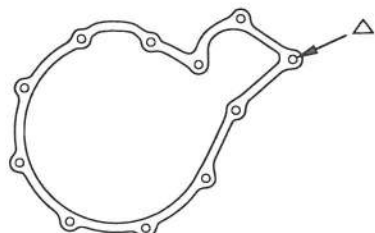
ENGINE	LOCATION	MATERIAL	REMARKS
	Camshaft lobes/journals Valve stem (valve guide sliding surface) Rocker arm slipper surface Rocker arm shaft outer surface Connecting rod bearing surface Crankshaft journals Clutch outer guide outer surface Transmission gear shift fork groove Transmission collar inner and outer surface Transmission spline collar outer surface Connecting rod small end inner surface	Molybdenum disulfide oil (a mixture of 1/2 engine oil and 1/2 molybdenum disulfide grease)	
	Piston outer surface Piston ring outer surface Piston pin outer surface Primary drive gear bolt threads and seating surface Flywheel bolt threads and seating surface Starter one-way clutch sliding lock surface Starter idle and reduction gear shaft outer surface Clutch center lock nut threads Clutch lifter arm-to-right crankcase cover sliding surface Clutch lifter rod-to-right crankcase cover sliding surface Clutch disc outer surface Cylinder stud bolt threads Cylinder head 8 mm bolt threads Valve adjusting screw threads and seating surface Connecting rod bolt/nut threads and seating surface Cylinder head mounting bolt and nut seating surface Cylinder head cover mount rubber seal whole surface Transmission gear tooth Oil filter cartridge threads and O-ring Each bearings rolling area Each O-rings	Engine oil	
	Air cleaner housing-to-chamber band inside surface Crankshaft hole cap threads Timing hole cap threads Each oil seal lips	Multi-purpose grease	
	Oil pressure switch threads 3 – 4 mm (0.12 – 0.16 in)  Right and left crankcase mating surface  Fan motor switch threads	Sealant	

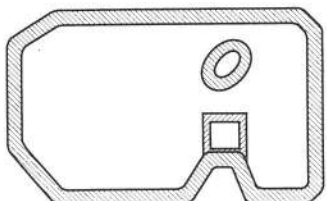
ENGINE (Cont'd)		
LOCATION	MATERIAL	REMARKS
<p>Right crankcase cover mating surface (After 2000)</p>  <p>Left crankcase cover mating surface (After 2000)</p> 	Sealant	
<p>Cam sprocket bolt threads Starter one-way clutch housing bolt threads Oil pump driven sprocket bolt threads Stator wire holder socket bolt threads Gearshift cam plate bolt threads Transmission bearing set plate bolt threads Countershaft oil seal set plate bolt threads Cam chain tensioner set plate bolt threads Stator mounting bolt threads Oil filter boss crankcase side threads Ignition pulse generator bolt threads Left crankcase cover bolt threads (marked "△")</p> 	Locking agent	<p>Coating width: $6.5 \pm 1\text{mm}$ ($0.26 \pm 0.04\text{ in}$)</p> 
<p>Cylinder head cover-to-gasket groove</p> 	HONDA BOND A or equivalent	

FRAME	LOCATION	MATERIAL	REMARKS
	Steering head bearing sliding surface Steering head dust seal lips Clutch lever pivot bolt sliding surface Throttle grip inner surface Throttle pipe rolled-up portion Throttle cable end Rear wheel axle sliding surface Rear brake cam sliding surface Rear brake shoe-to-cam sliding surface Rear brake anchor pin sliding surface Rear brake pedal and rod pivot sliding surface Rear brake pivot bolt sliding surface Swingarm pivot dust seal lips Swingarm pivot needle bearing rolling area Side stand pivot sliding area Main and pillion step pivot sliding area Each dust seal lips Each oil seal lips	Multi-purpose grease	Spreading 1.0 – 2.0 g Spreading 0.2 – 0.3 g Spreading 0.5 – 1.0 g Spreading 0.5 – 1.0 g Spreading 1.0 g
	Side stand pivot sliding surface Gearshift pedal pivot sliding surface	Molybdenum disulfide grease	Spreading 1.0 g
	Thermosensor threads Cylinder joint collar O-ring	Sealant	
	Steering top threads Rear brake cam felt seal	Engine oil	
	Brake master cylinder cups Brake master piston Brake caliper piston seals	DOT 4 brake fluid	
	Brake lever pivot and piston tips Brake caliper dust seals Brake caliper slide pin sliding surface Brake caliper bracket pin sliding surface	Silicone grease	Spreading 0.1 g min. Spreading 0.4 g min. Spreading 0.4 g min.
	Brake caliper slide pin threads Brake caliper bracket pin threads Front fork socket bolt threads	Locking agent	
	Axle and distance collar whole surface	Gear oil	
	Drive chain	#80 – 90 gear oil	
	Handle grip rubber inside	Pro-Honda Handgrip Cement or equivalent	Spreading 80 % min.
	Brake caliper bracket-to-retainer seating area	Threebond #1521	
	Front fork rebound spring Front fork spring Fork cap O-ring	Pro-Honda Suspension Fluid SS-8	
	Inside cables	Cable lubricant	

GENERAL INFORMATION

CABLE & HARNESS ROUTING

VT750C :
VT750CD/CD2 ('98 - 2000) :

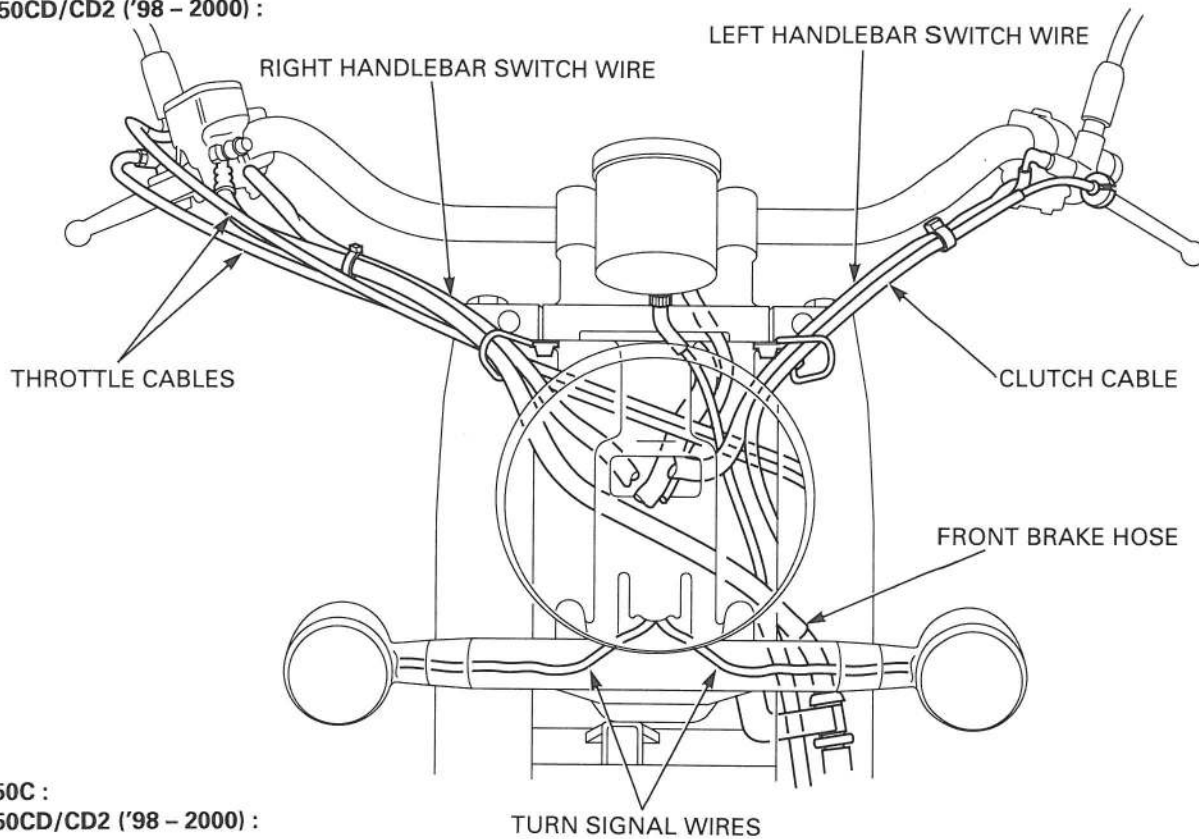

VT750C :
VT750CD/CD2 ('98 - 2000) :

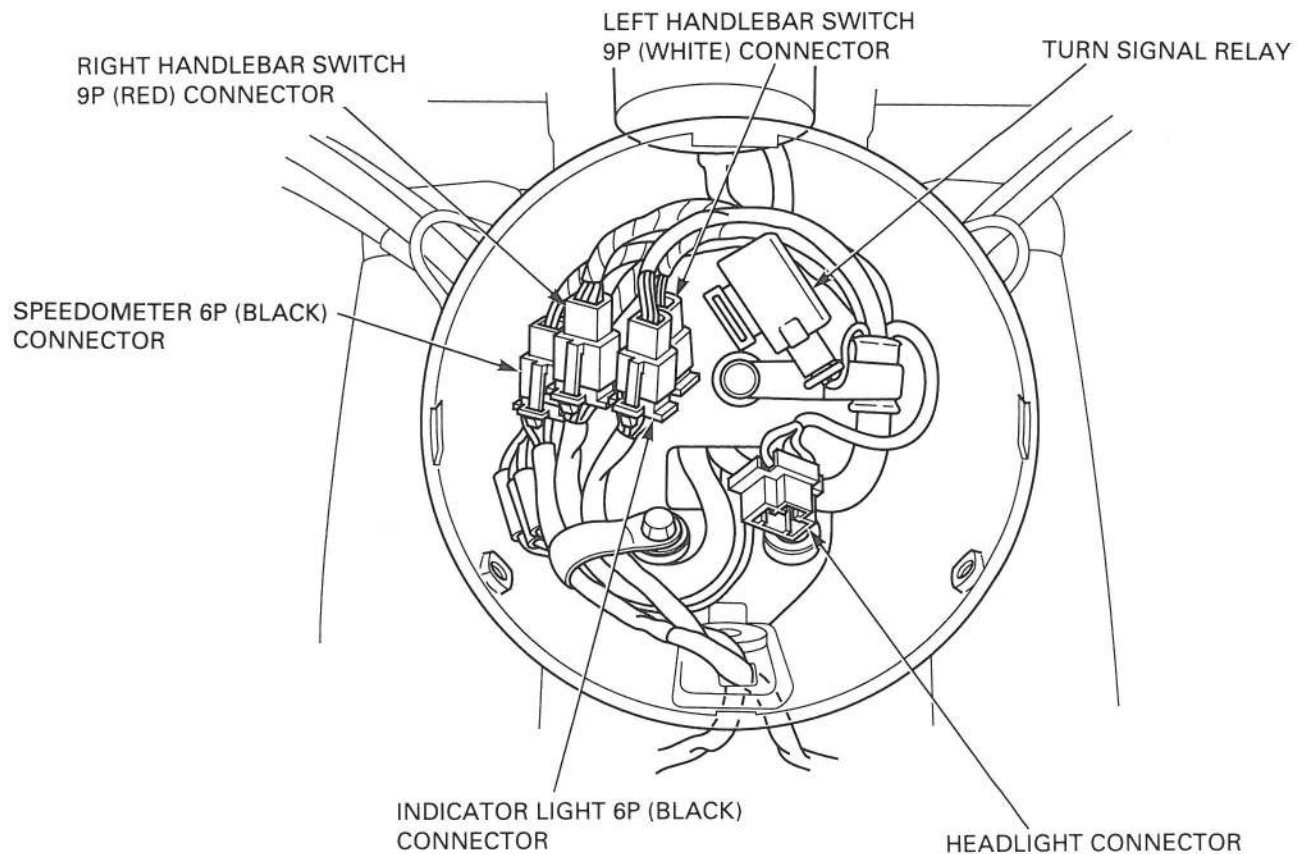

VT750CD/CD2 (After 2000) :
VT750C3/CD3 :

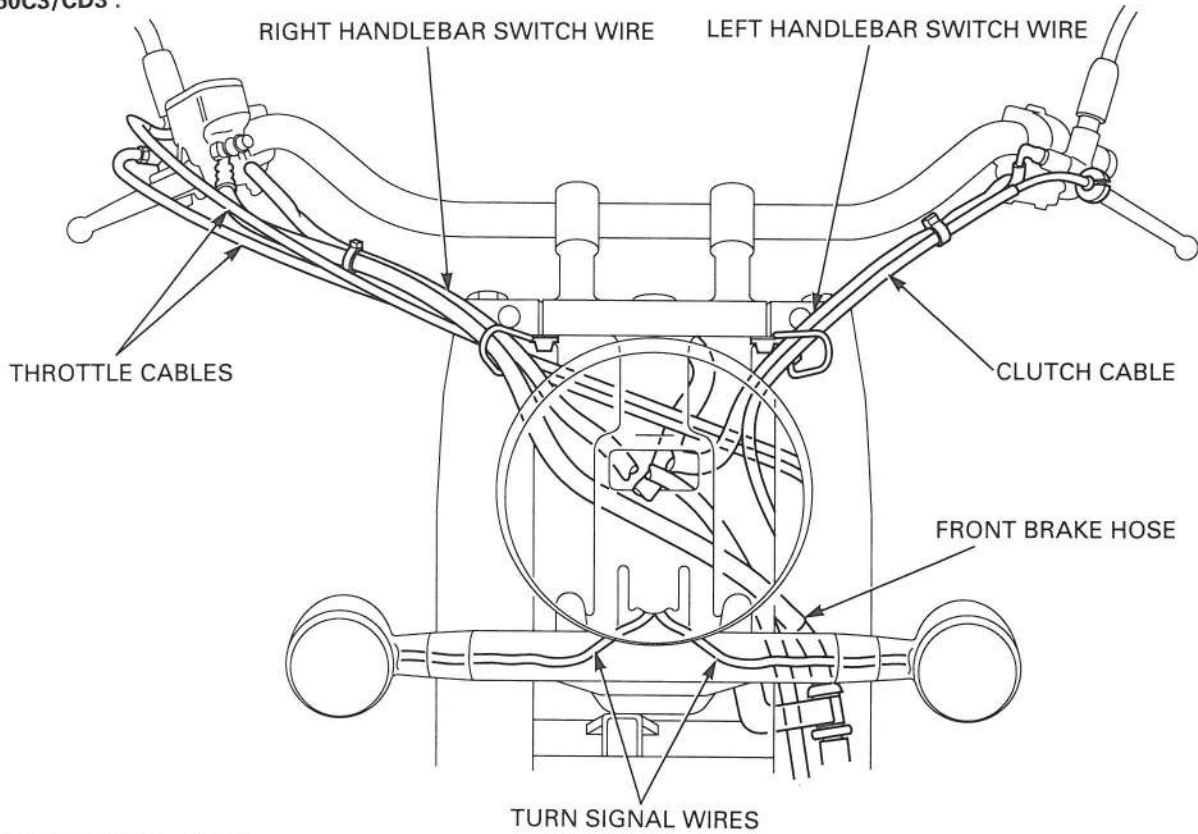

VT750CD/CD2 (After 2000) :
VT750C3/CD3 :

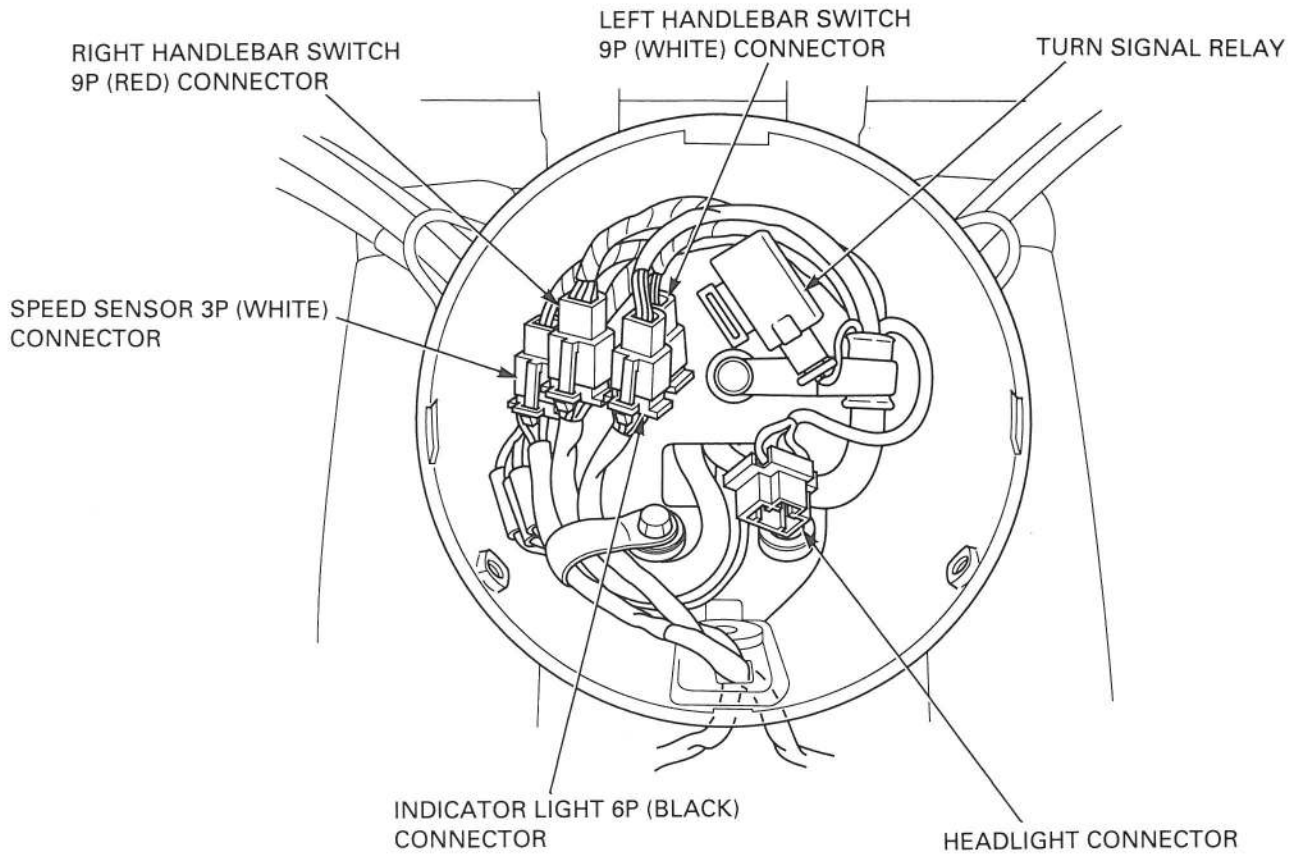

GENERAL INFORMATION

VT750C :
VT750CD/CD2 ('98 - 2000) :

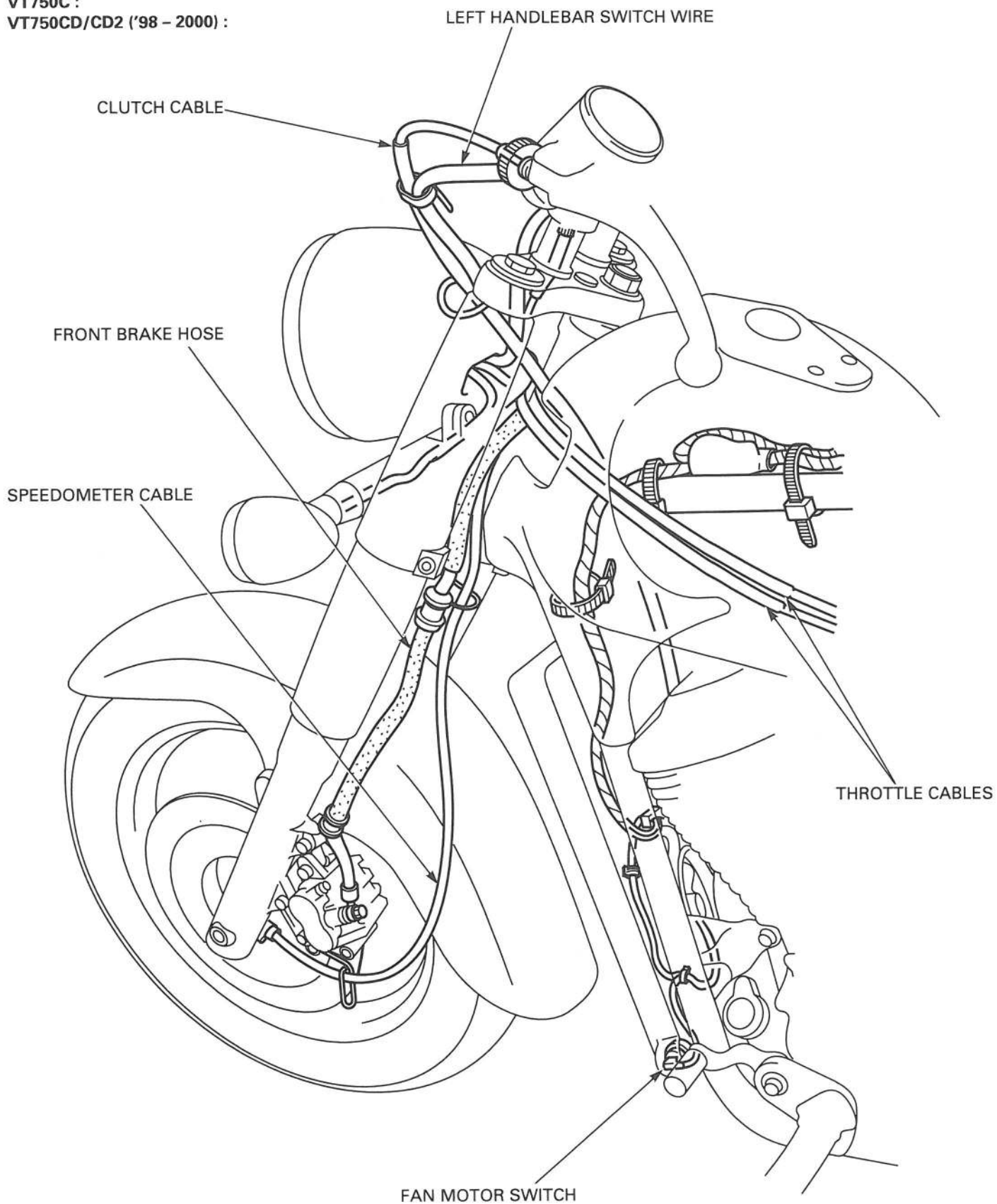

VT750CD/CD2 (After 2000) :
VT750C3/CD3 :

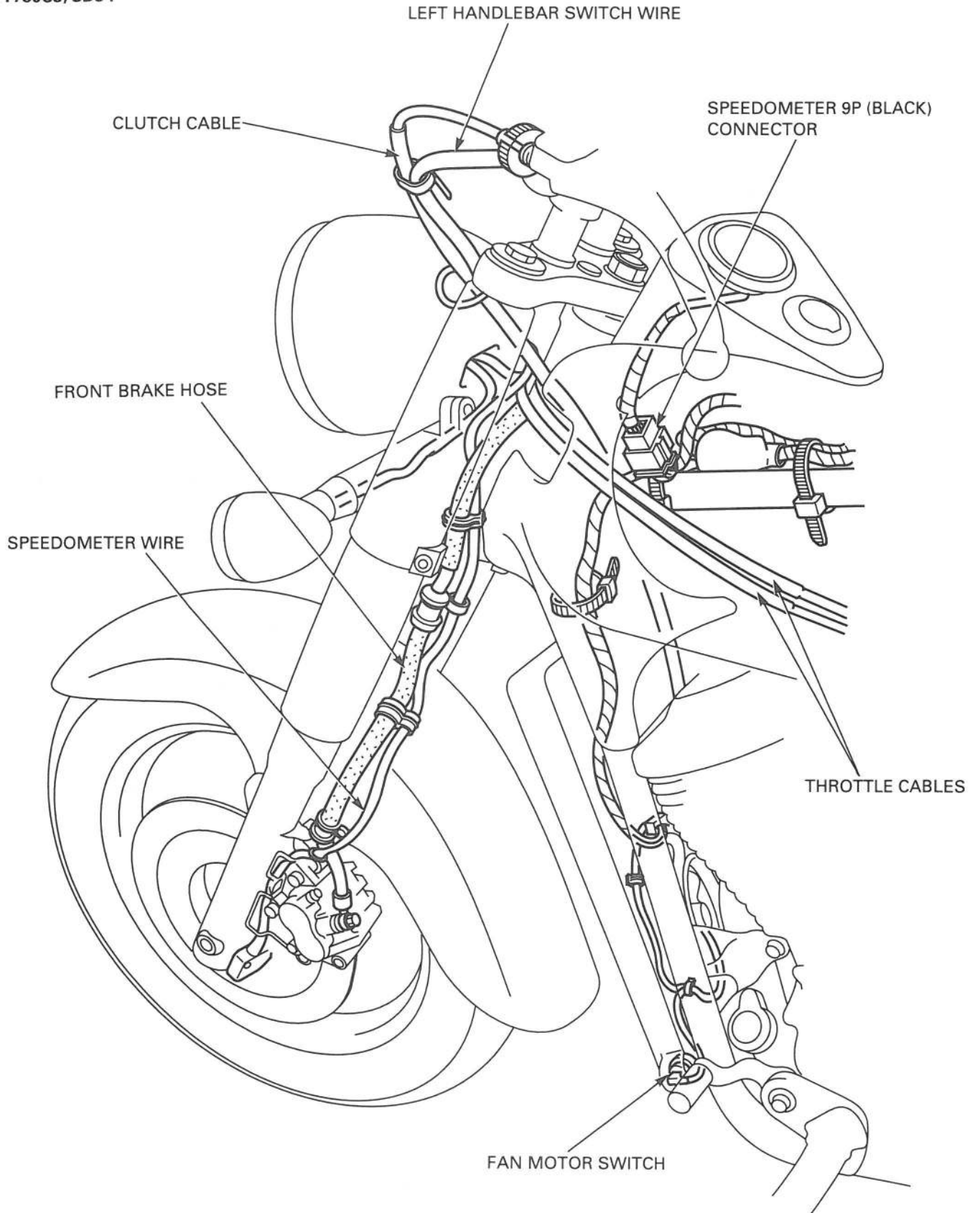

GENERAL INFORMATION

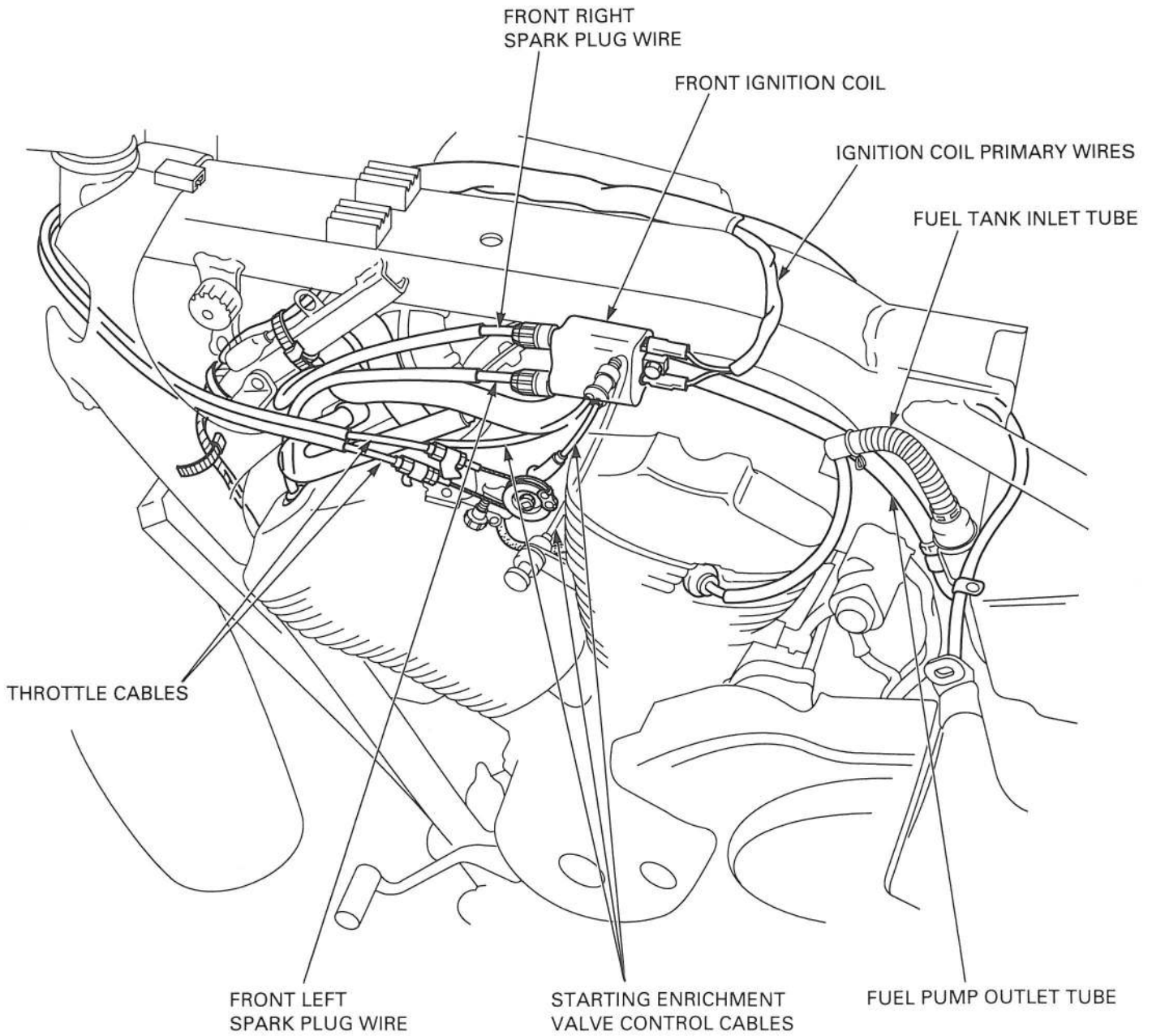

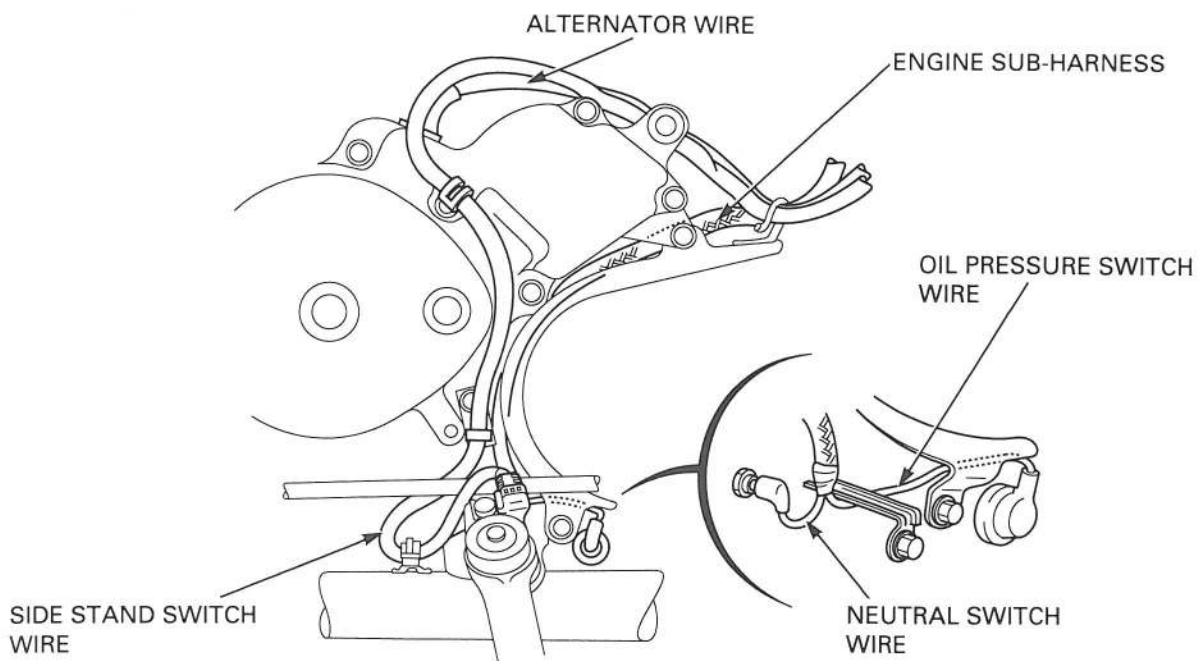
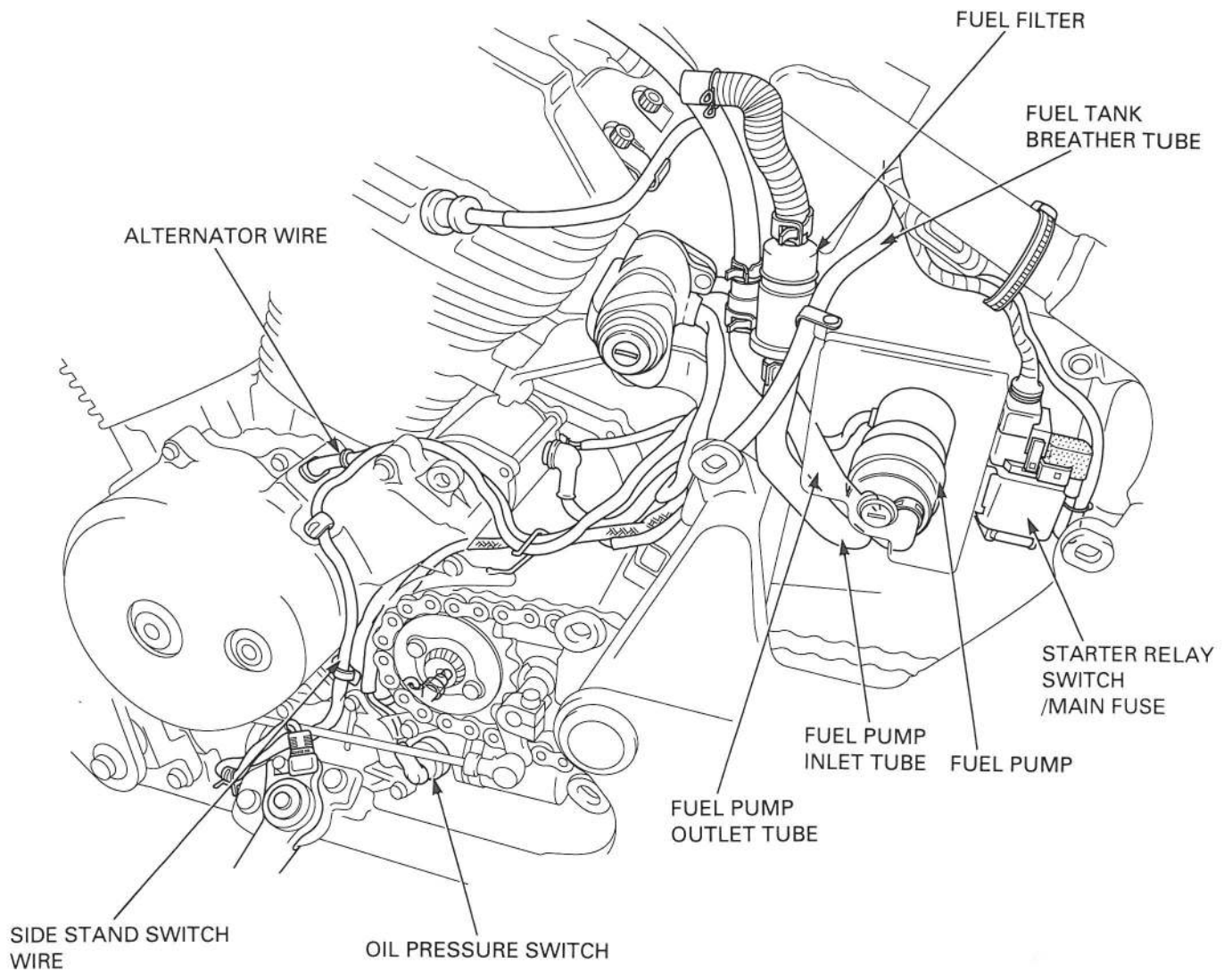

GENERAL INFORMATION

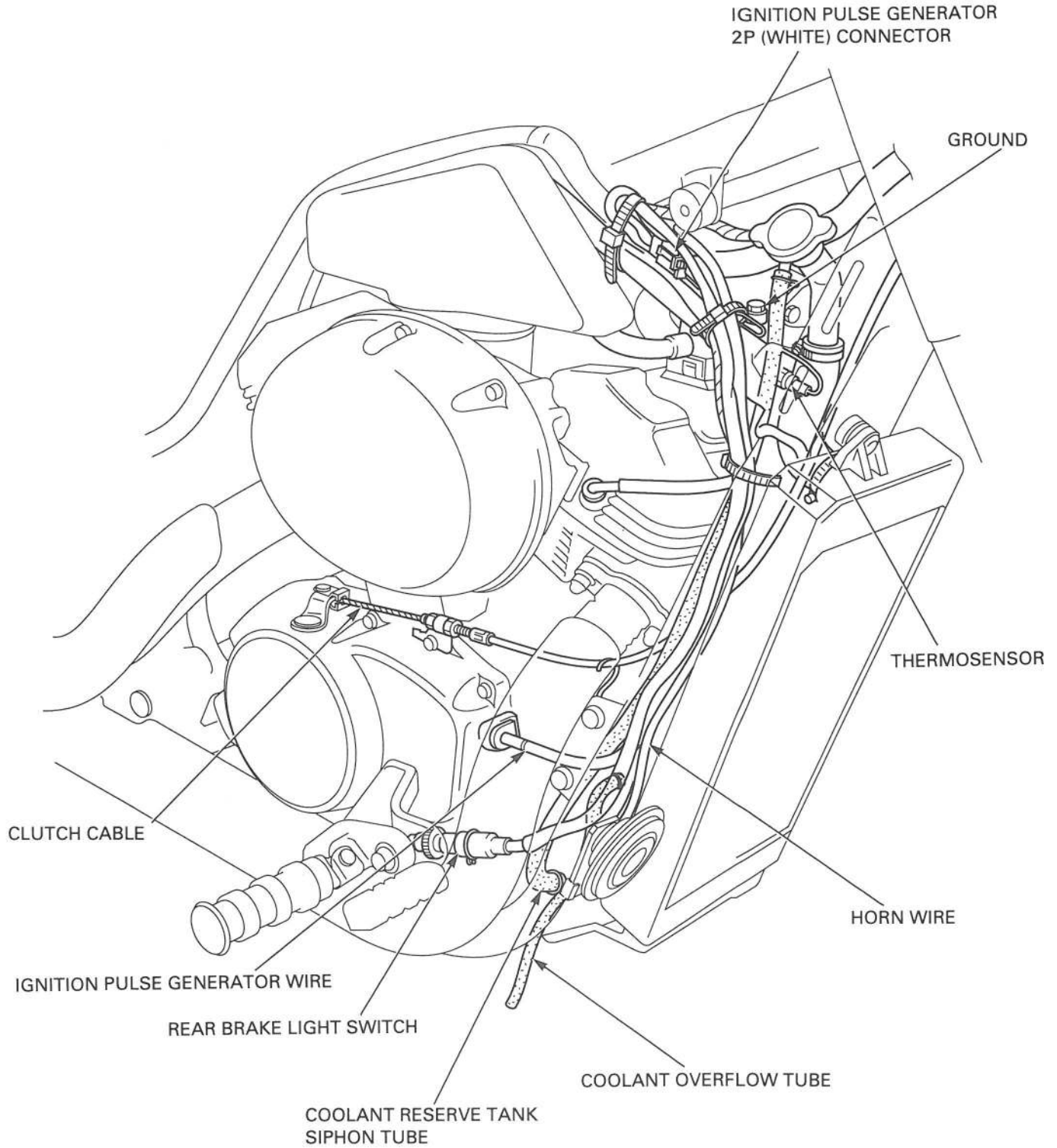

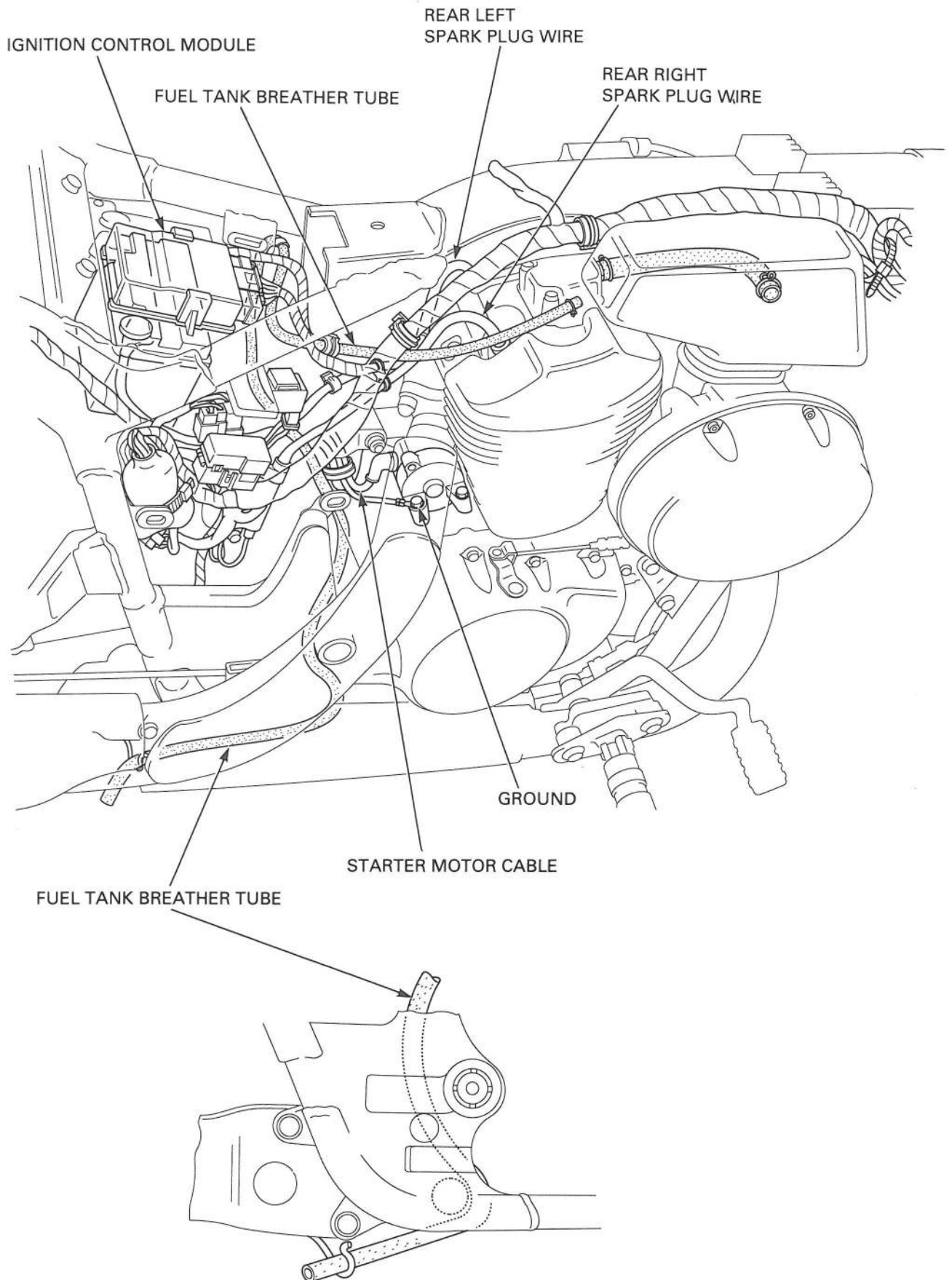

GENERAL INFORMATION

VT750C :

VT750CD/CD2 ('98 - 2000) :

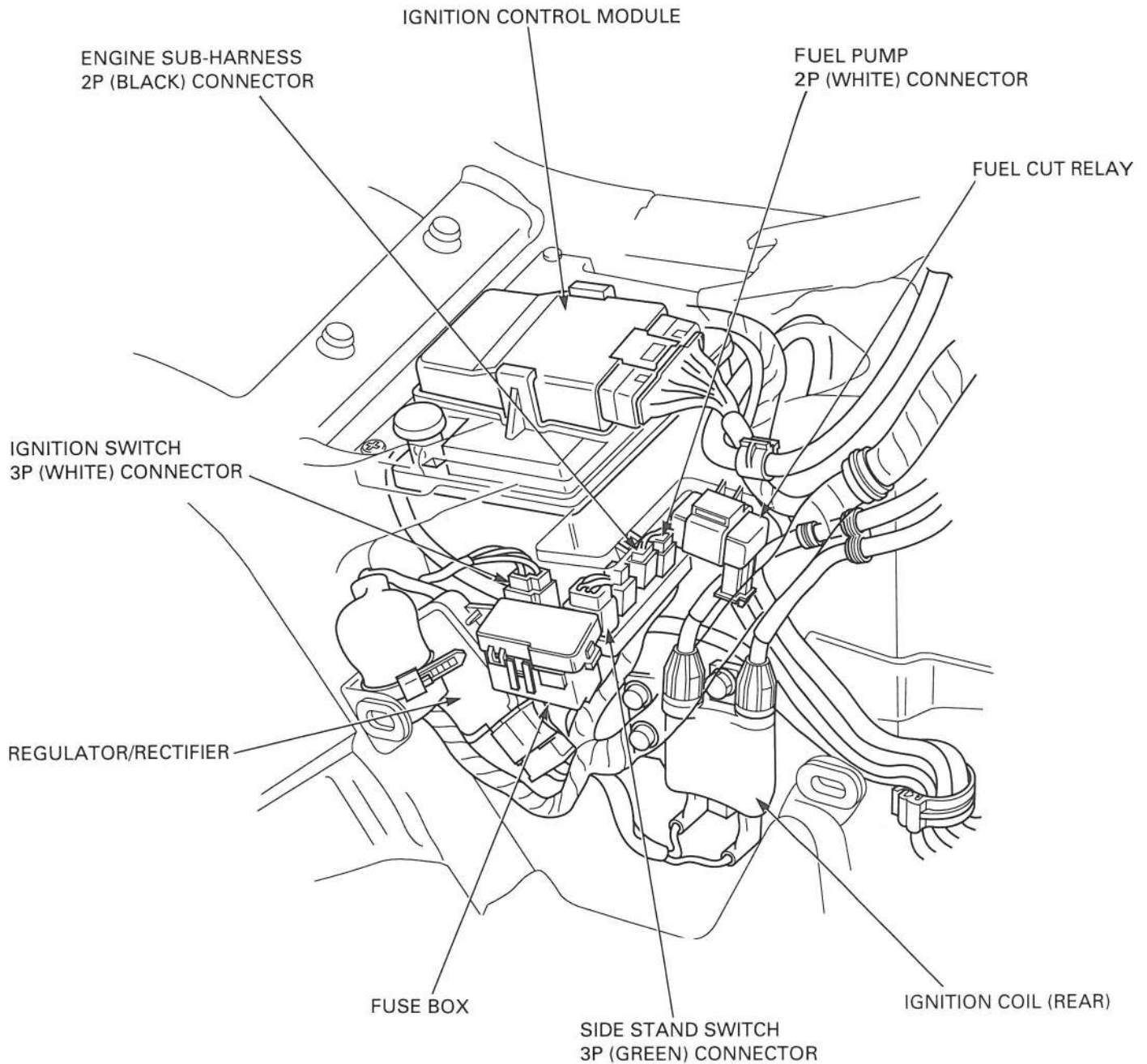

VT750CD/CD2 (After 2000) :
VT750C3/CD3 :

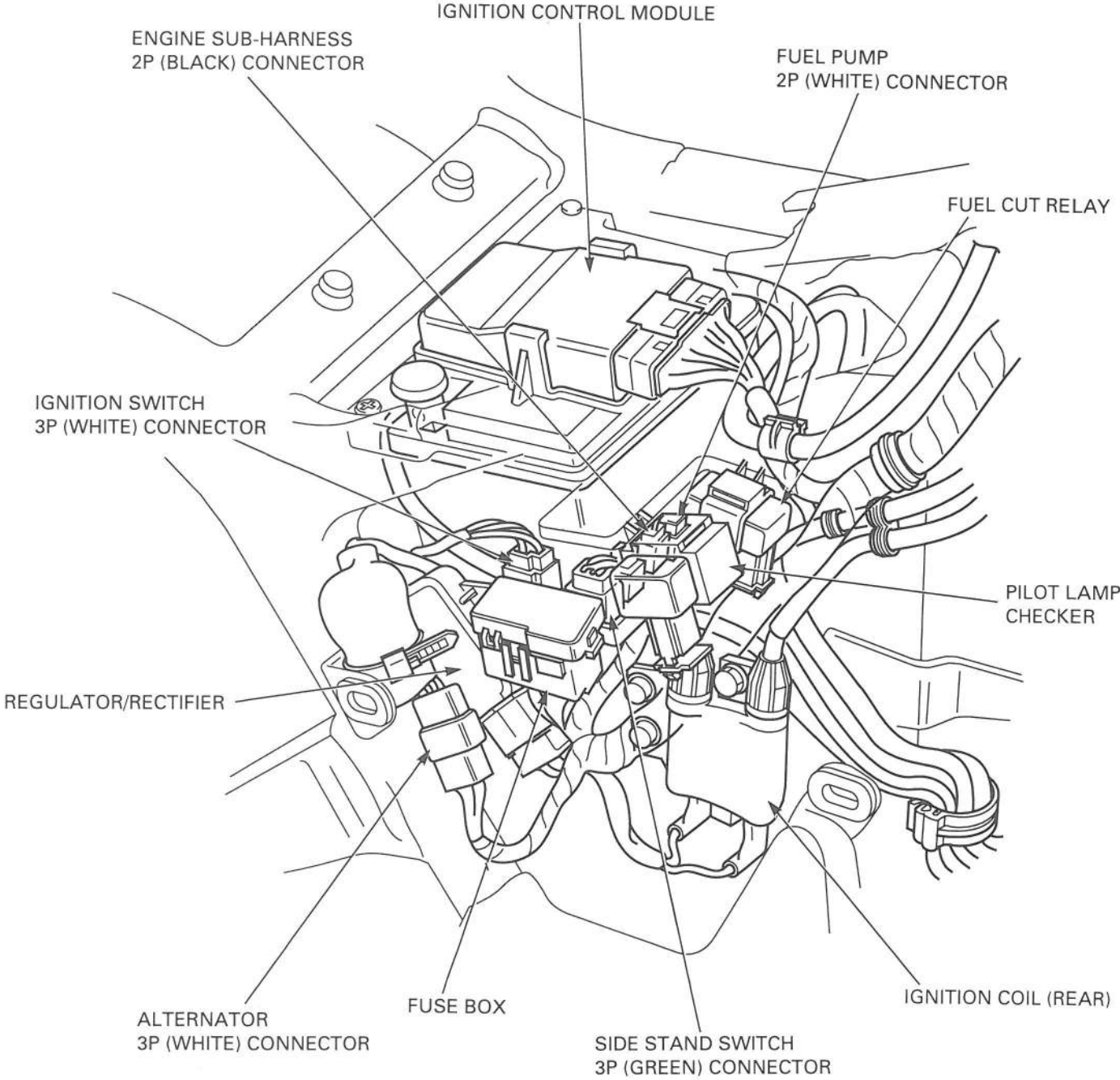

GENERAL INFORMATION

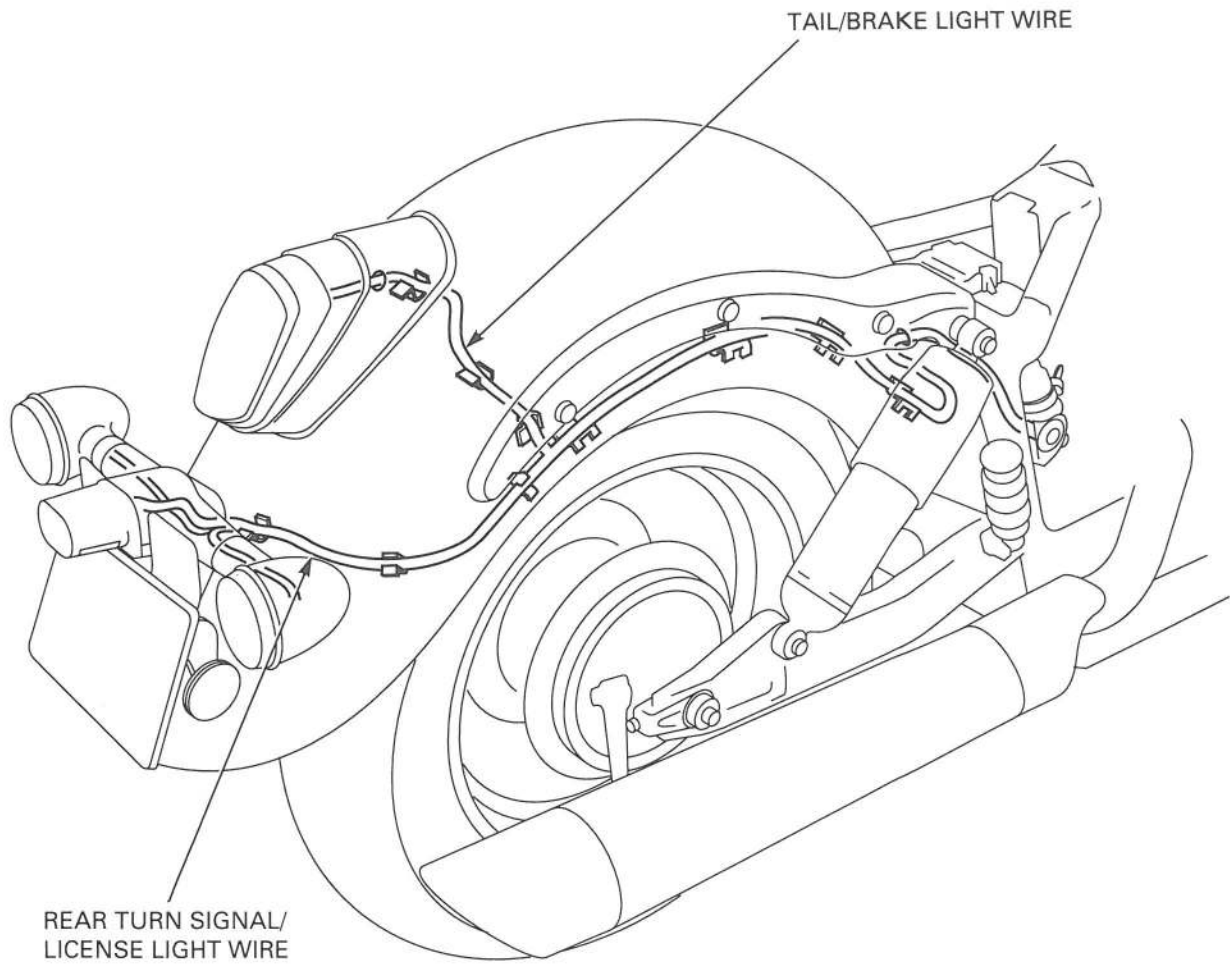

EVAPORATIVE EMISSION CONTROL SYSTEM (CALIFORNIA TYPE ONLY)

NOTE:

The hoses shown below are numbered as they appear on the Vacuum Hose Routing Diagram Label.

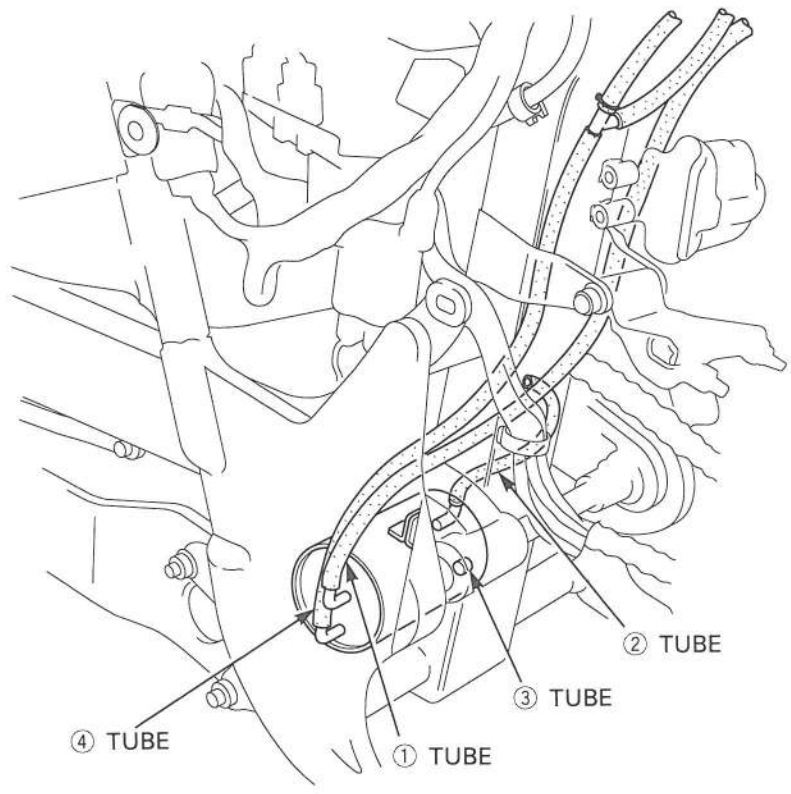
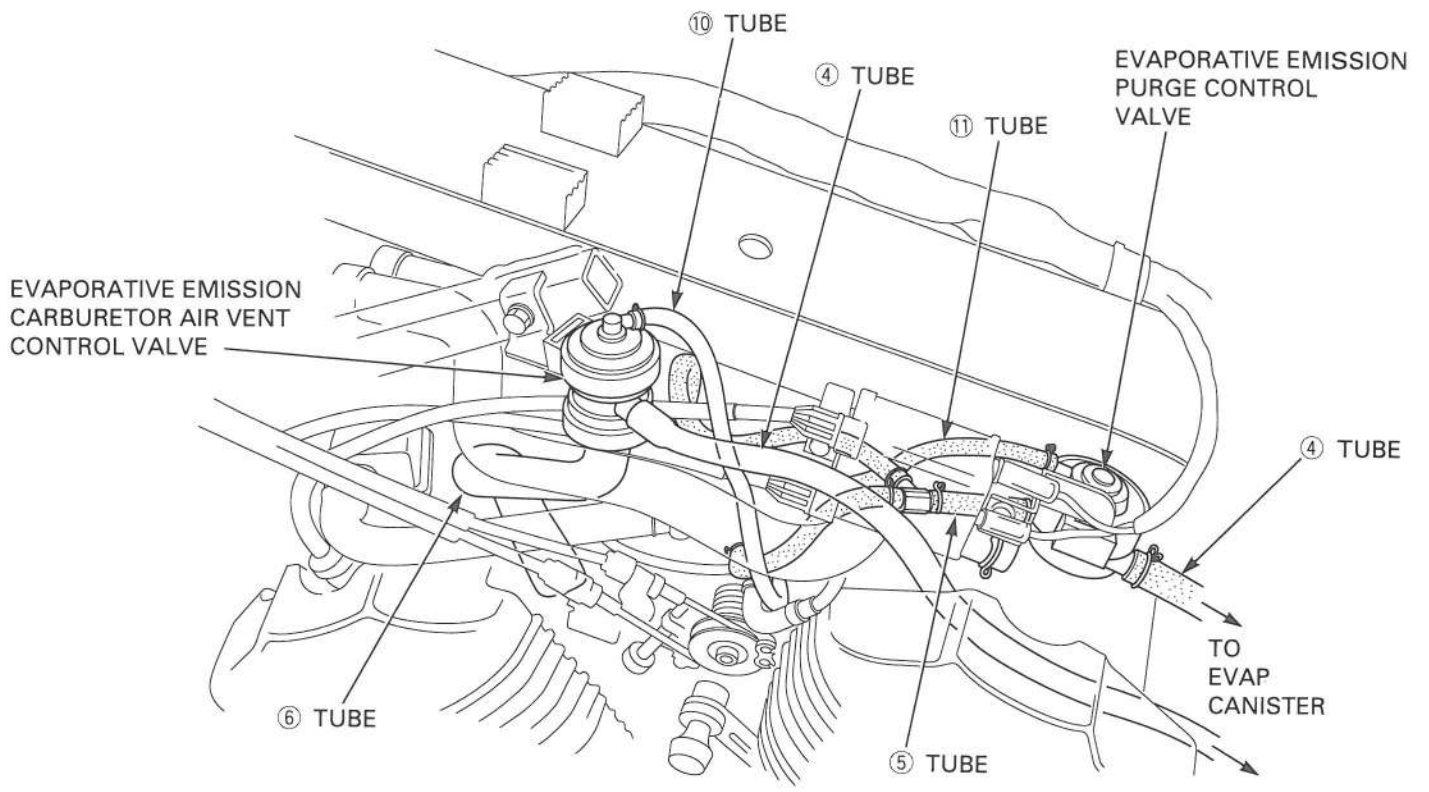

GENERAL INFORMATION

EMISSION CONTROL SYSTEMS

The U.S. Environmental Protection Agency, Transport Canada, and California Air Resources Board (CARB) require manufacturers to certify that their motorcycles comply with applicable exhaust emissions standards during their useful life, when operated and maintained according to the instructions provided, and that motorcycles built after January 1, 1983 comply with applicable noise emission standards for one year or 6,000 km (3,730 miles) after the time of sale to the ultimate purchaser, when operated and maintained according to the instructions provided. Compliance with the terms of the Distributor's Limited Warranty for Honda Motorcycle Emission Control Systems is necessary in order to keep the emissions system warranty in effect.

SOURCE OF EMISSIONS

The combustion process produces carbon monoxide and hydrocarbons. Control of hydrocarbons is very important because, under certain conditions, they react to form photochemical smog when subjected to sunlight. Carbon monoxide does not react in the same way, but it is toxic.

Honda Motor Co., Ltd. utilizes lean carburetor settings as well as other systems, to reduce carbon monoxide and hydrocarbons.

EXHAUST EMISSION CONTROL SYSTEM

The exhaust emission control system is composed of a lean carburetor setting, and no adjustments should be made except idle speed adjustment with the throttle stop screw. The exhaust emission control system is separate from the crankcase emission control system.

CRANKCASE EMISSION CONTROL SYSTEM

The engine is equipped with a closed crankcase system to prevent discharging crankcase emission into the atmosphere. Blow-by gas is returned to the combustion chamber through the air cleaner and carburetor.

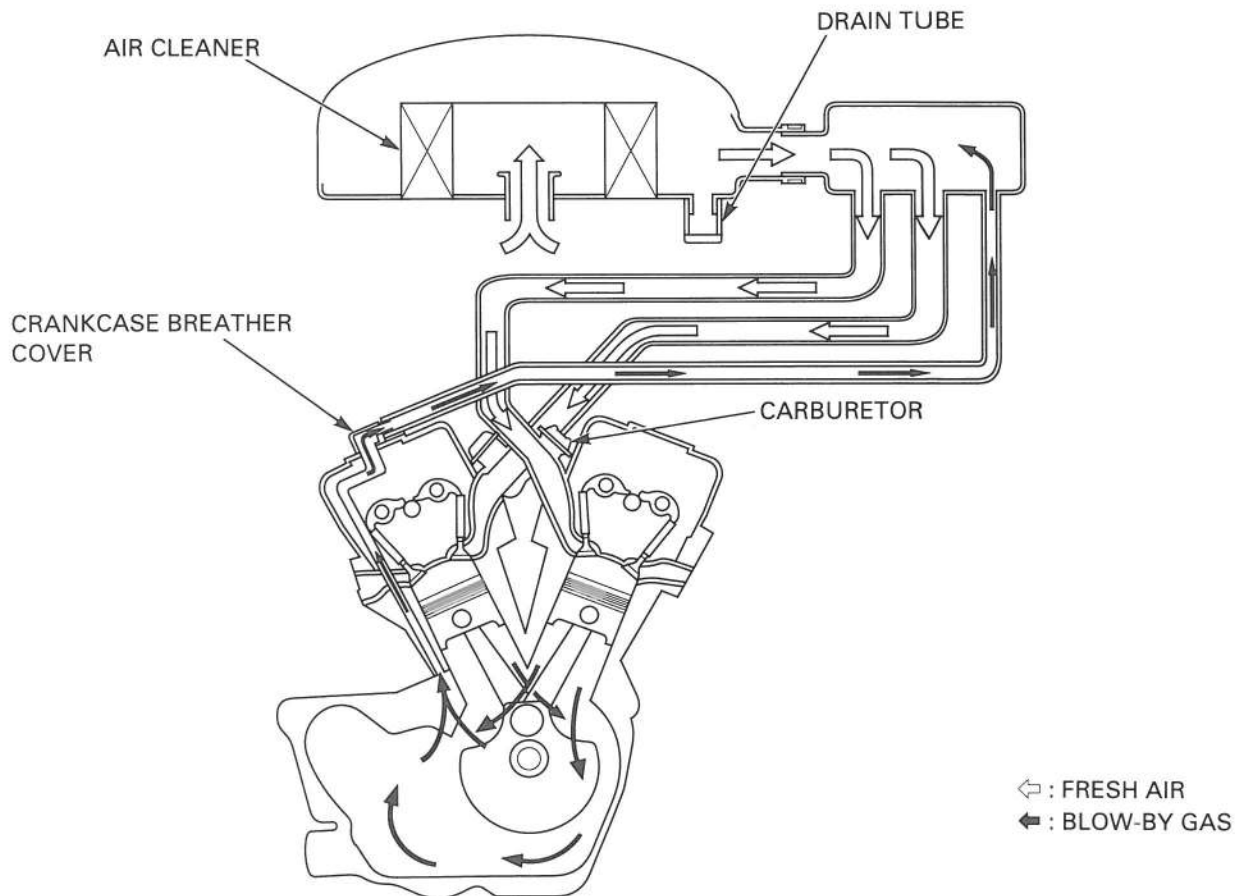

EVAPORATIVE EMISSION CONTROL SYSTEM (CALIFORNIA TYPE ONLY)

This model complies with California Air Resources Board evaporative emission requirements.

Fuel vapor from the fuel tank and carburetors is routed into the evaporative emission (EVAP) canister where it is absorbed and stored while the engine is stopped. When the engine is running and the evaporative emission (EVAP) purge control valve is open, fuel vapor in the EVAP canister is drawn into the engine through the carburetor. At the same time, the EVAP carburetor air vent (CAV) control valve is open and air is drawn into the carburetor through the valve.

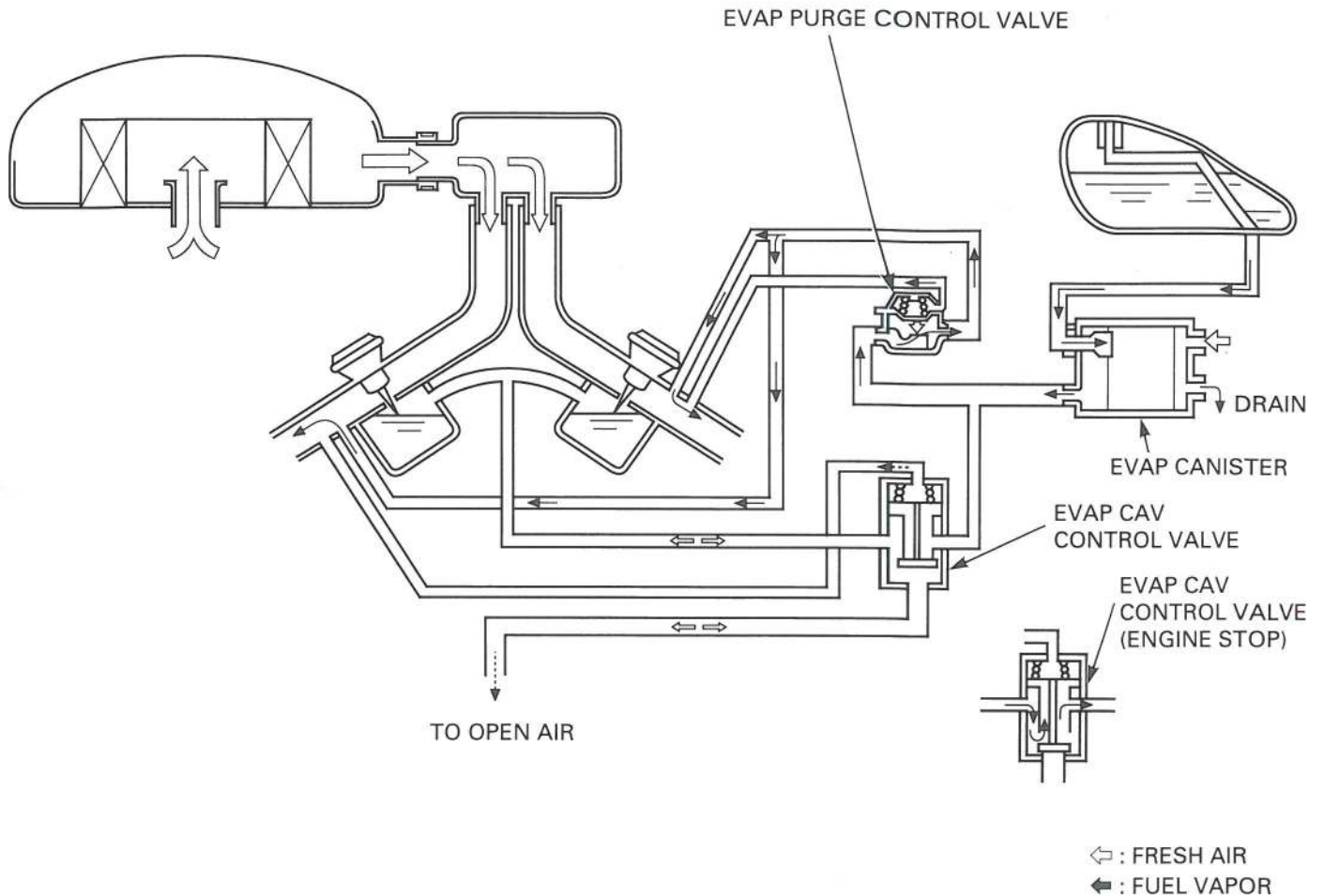

NOISE EMISSION CONTROL SYSTEM

TAMPERING WITH THE NOISE CONTROL SYSTEM IS PROHIBITED: Federal law prohibits the following acts or the causing thereof: (1) The removal or rendering inoperative by any person, other than for purposes of maintenance, repair or replacement, of any device or element of design incorporated into any new vehicle for the purpose of noise control prior to its sale or delivery to the ultimate purchaser or while it is in use; (2) the use of the vehicle after such device or element of design has been removed or rendered inoperative by any person.

AMONG THOSE ACTS PRESUMED TO CONSTITUTE TAMPERING ARE THE ACTS LISTED BELOW:

1. Removal of, or puncturing of the muffler, baffles, header pipes or any other component which conducts exhaust gases.
2. Removal of, or puncturing of any part of the intake system.
3. Lack of proper maintenance.
4. Replacing any moving parts of the vehicle, or parts of the exhaust or intake system, with parts other than those specified by the manufacturer.

GENERAL INFORMATION

EMISSION CONTROL INFORMATION LABELS

An Emission Control Information Label is located on the inside of the left side cover as shown.

The left side cover must be removed to read it. Refer to page 2-3 for side cover removal.

It gives base tune-up specifications.

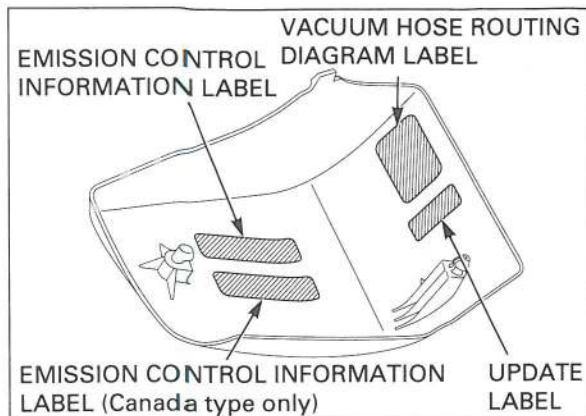

VEHICLE EMISSION CONTROL INFORMATION UPDATE LABEL

After making a high altitude carburetor adjustment, attach an update label on the inside of the left side cover as shown.

Instructions for obtaining the update label are given in Service Letter No. 132.

When readjusting the carburetors back to the low altitude specifications, be sure to remove this update label.

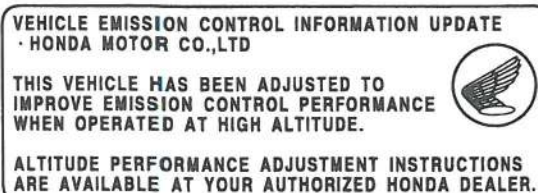

VACUUM HOSE ROUTING DIAGRAM LABEL (CALIFORNIA TYPE ONLY)

The Vacuum Hose Routing Diagram Label is on the inside of the left side cover as shown.

The left side cover must be removed to read it. Refer to page 2-3 for side cover removal.

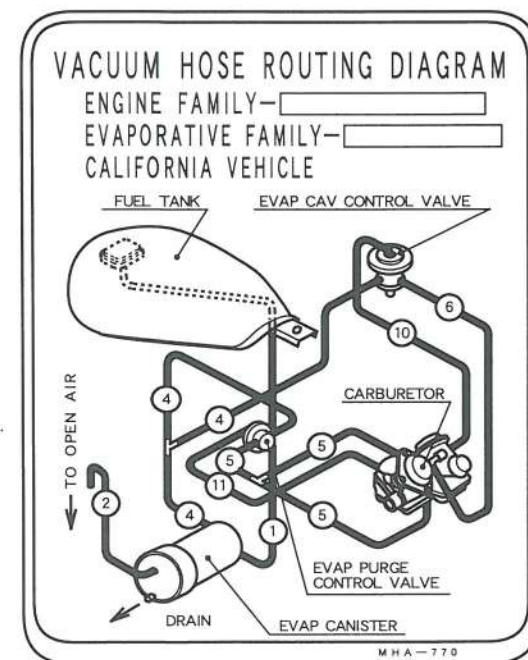

2. FRAME/BODY PANELS/EXHAUST SYSTEM

SERVICE INFORMATION	2-1	FUEL TANK	2-4
TROUBLESHOOTING	2-1	REAR FENDER	2-6
SEAT	2-2	GRAB RAIL	2-6
STEERING COVER	2-3	EXHAUST PIPE/MUFFLER	2-7
SIDE COVER	2-4		

SERVICE INFORMATION

GENERAL

⚠ WARNING

- Gasoline is extremely flammable and is explosive under certain conditions. Work in a well ventilated area. Smoking or allowing flames or sparks in the work area or where the gasoline is stored can cause a fire or explosion.
- Engine and exhaust system parts become very hot and remain hot for some time after the engine is run. Wear insulated gloves or wait until the engine and exhaust system have cooled before handling these parts.
- If the engine must be running to do some work, make sure the area is well ventilated. Never run the engine in an enclosed area. The exhaust contains poisonous carbon monoxide gas that may cause loss of consciousness and may lead to death. Run the engine in an open area or with an exhaust evacuation system in enclosed area.

- Work in a well ventilated area. Smoking or allowing flames or sparks in the work area or where gasoline is stored can cause a fire or explosion.
- This section covers removal and installation of the body panels, fuel tank and exhaust system.
- Always replace the exhaust pipe gaskets when removing the exhaust pipe from the engine.
- Always inspect the exhaust system for leaks after installation.

TORQUE VALUES

Exhaust pipe joint nut	25 N•m (2.5 kgf•m, 18 lbf•ft)
Muffler bracket nut	26 N•m (2.7 kgf•m, 20 lbf•ft)
Muffler mounting bolt	26 N•m (2.7 kgf•m, 20 lbf•ft)
Front seat bolt	26 N•m (2.7 kgf•m, 20 lbf•ft)
Rear seat bolt	9 N•m (0.9 kgf•m, 6.5 lbf•ft)
Rear fender bolt	26 N•m (2.7 kgf•m, 20 lbf•ft)
Grab rail 10 mm bolt	64 N•m (6.5 kgf•m, 47 lbf•ft)
24 mm nut	88 N•m (9.0 kgf•m, 65 lbf•ft)
14 mm bolt	108 N•m (11.0 kgf•m, 80 lbf•ft)
Fuel tank bolt	19 N•m (1.9 kgf•m, 14 lbf•ft)
Fuel valve	34 N•m (3.5 kgf•m, 25 lbf•ft)
Battery box bolt	10 N•m (1.0 kgf•m, 7 lbf•ft)
Tool box cover screw	2 N•m (0.2 kgf•m, 1.4 lbf•ft)

TROUBLESHOOTING

Excessive exhaust noise

- Broken exhaust system
- Exhaust gas leak

Poor performance

- Deformed exhaust system
- Exhaust gas leak
- Clogged muffler

SEAT

REMOVAL

CAUTION:

Be careful not to damage the rear fender surface.

Remove the rear seat mounting bolt.
Slide seat forward and lift up to remove the rear seat.



Remove the front seat mounting bolt.
Slide front seat back and lift up to remove the front seat.



INSTALLATION

CAUTION:

Be careful not to damage the rear fender surface.

Install the front seat by inserting the hook of the seat under the raised lip of the fuel tank and push the seat forward.



Align the bolt holes and tighten the bolt to the specified torque.

TORQUE: 26 N·m (2.7 kgf·m, 20 lbf·ft)



Install the rear seat by inserting the hook of the seat over the front seat mounting bolt and push the seat backward.



Align the bolt holes and tighten the bolt to the specified torque.

TORQUE: 9 N·m (0.9 kgf·m, 6.5 lbf·ft)

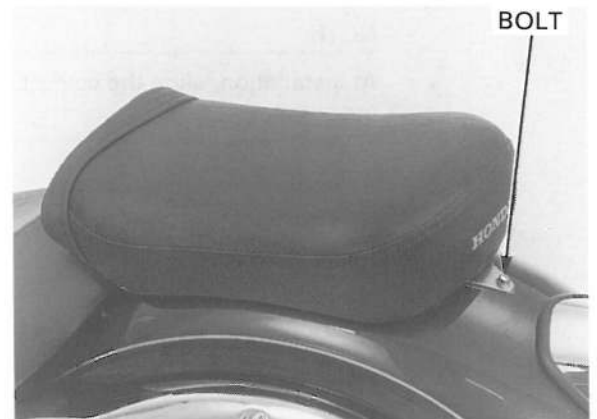

STEERING COVER

REMOVAL/INSTALLATION

CAUTION:

Be careful not to break the steering cover tabs.

Remove the fuel tank (page 2-4).

Remove the trim clips.
Remove the right and left covers as assembly.
Remove the joint clip and separate the covers.

Installation is in the reverse order of removal.

NOTE:

Check that the wire harness do not interfere with handlebar rotation.

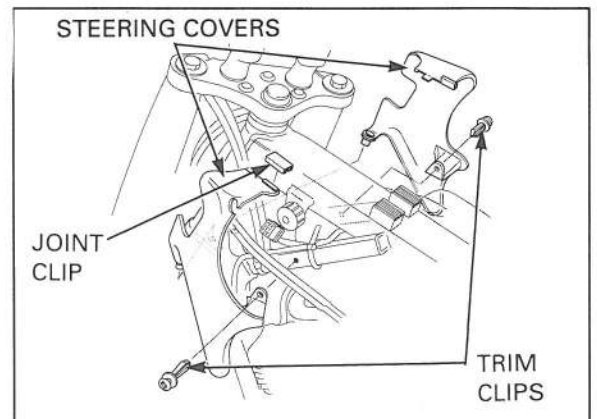

SIDE COVER

CAUTION:

Be careful not to break the side cover bosses.

NOTE:

Be careful not to dislodge the grommets in the frame.

Release the cover bosses from the grommets and side cover.

Installation is in the reverse order of removal.

NOTE:

At installation, align the cover bosses on the frame grommet.

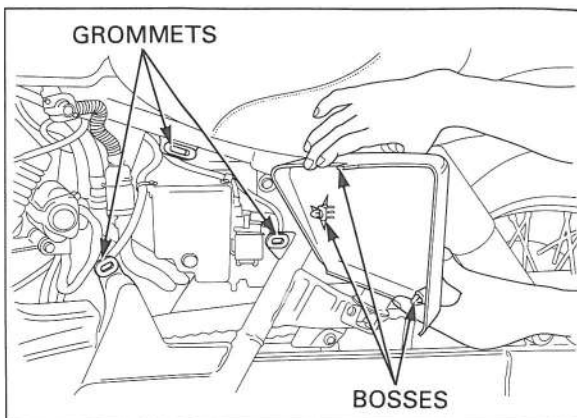

FUEL TANK

⚠ WARNING

Gasoline is extremely flammable and is explosive under certain conditions.

NOTE:

Before disconnecting fuel tube, turn the fuel valve "OFF".

REMOVAL/INSTALLATION

Remove the seat (page 2-2).

VT750C3/CD3 and
VT750CD/CD2
(after 2000):

Remove the speedometer (page 19-12).

Disconnect the fuel tube and air vent tube (to EVAP canister: California type only) from the fuel tank.

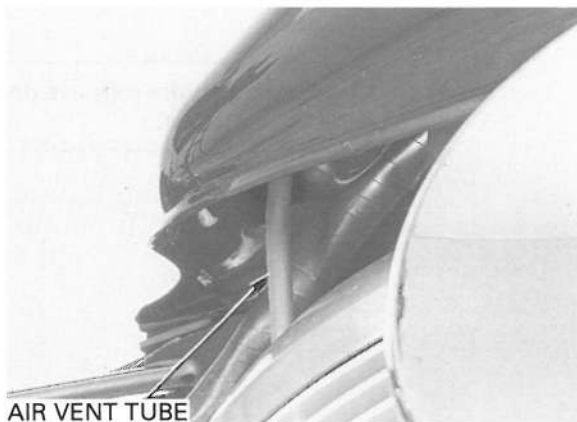
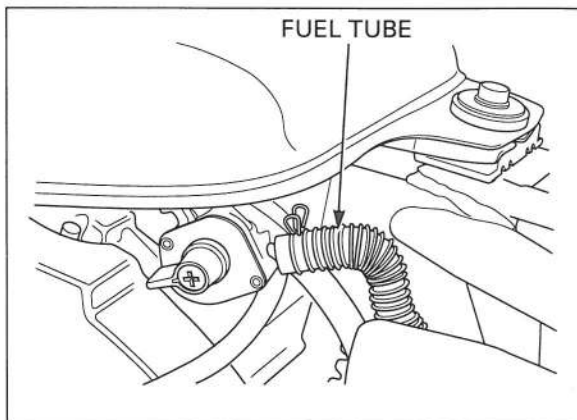

Remove the fuel tank mounting bolt, washer and collar.

Slide and remove the fuel tank to the back.

Installation is in the reverse order of removal.

TORQUE: Fuel tank mounting bolt:
19 N•m (1.9 kgf•m, 14 lbf•ft)

CAUTION:

Be careful not to pinch the wire harness between the fuel tank and the frame.

NOTE:

After installation, turn the fuel valve "ON" and check the fuel line for leakage.

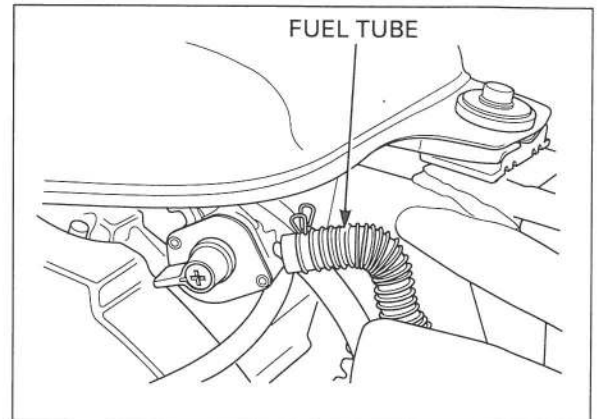
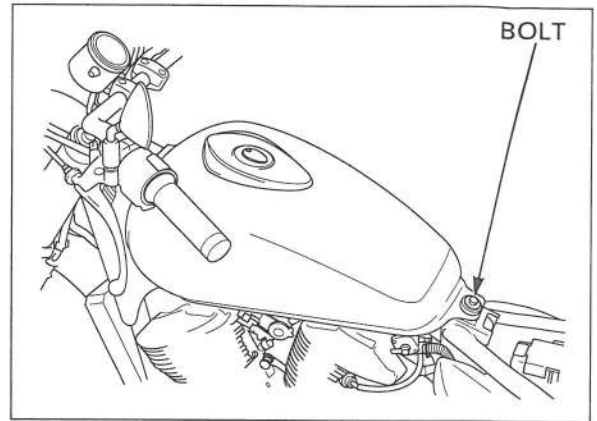

DISASSEMBLY/ASSEMBLY

Loosen the fuel valve nut and remove the fuel valve. Remove the fuel strainer screen and O-ring.

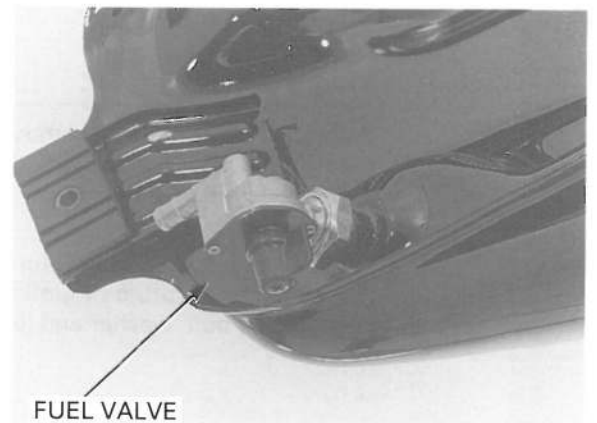

Check that the fuel strainer screen is not clogged or damaged. Clean or replace if necessary.

Assembly is in the reverse order of disassembly.

NOTE:

Always replace the O-ring with a new one.

TORQUE:
Fuel valve nut: 34 N•m (3.5 kgf•m, 25 lbf•ft)

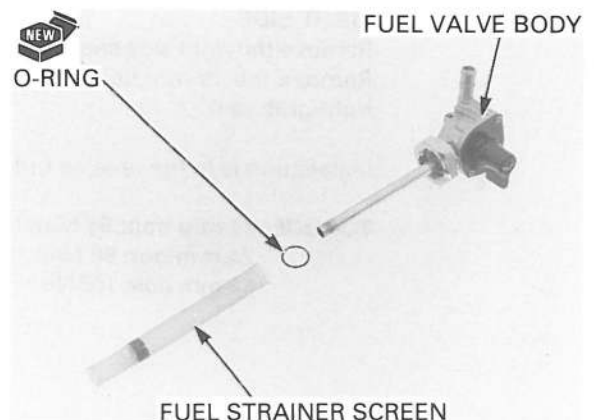

REAR FENDER

REMOVAL

NOTE:

Be careful not to scratch the fender or deform the connector stay.

Remove the front and rear seat (page 2-2).
Remove the right side cover (page 2-4).

Disconnect the tail/brake light connectors inside the connector boot.

Remove the bolts, washers and the rear fender.

Installation is in the reverse order of removal.

TORQUE: 26 N·m (2.7 kgf·m, 20 lbf·ft)

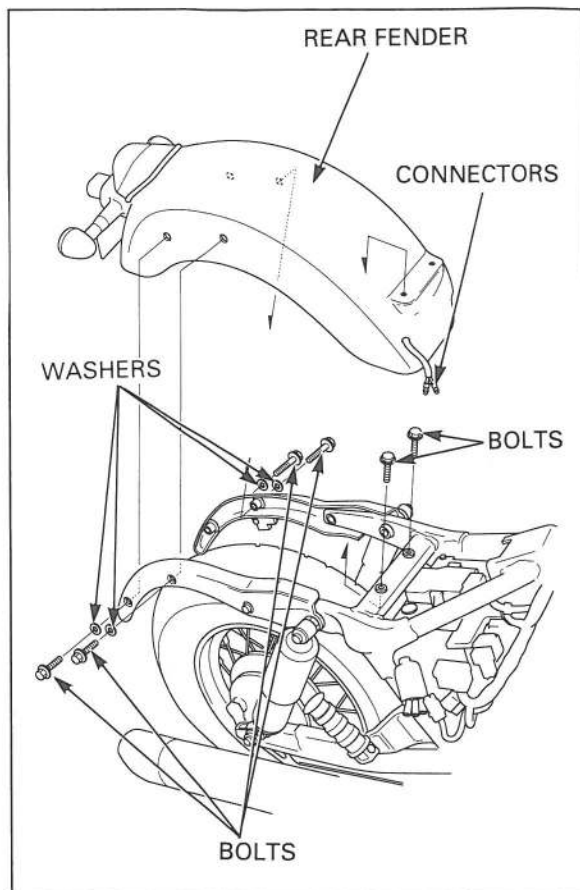

GRAB RAIL

NOTE:

The rear fender must be removed from the frame before servicing the each side grab rails.

LEFT SIDE

Loosen the left grab rail mounting nut located on the left shock absorber mounting bolt.
Remove the bolt, washer and left grab rail.

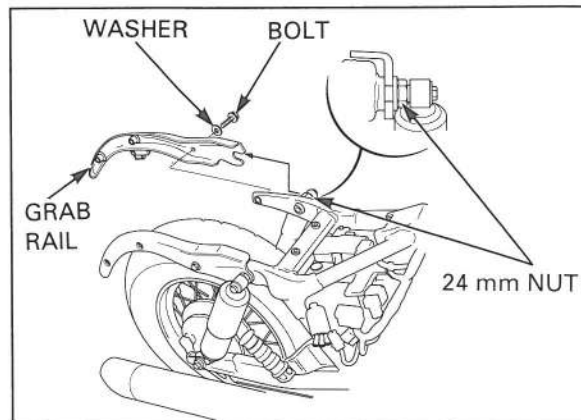

RIGHT SIDE

Remove the right side shock absorber (page 14-18).
Remove the 10 mm bolt, washer, 14 mm bolt and right grab rail.

Installation is in the reverse order of removal.

TORQUE: 10 mm bolt: 64 N·m (6.5 kgf·m, 47 lbf·ft)
24 mm nut: 88 N·m (9.0 kgf·m, 65 lbf·ft)
14 mm bolt: 108 N·m (11.0 kgf·m, 80 lbf·ft)

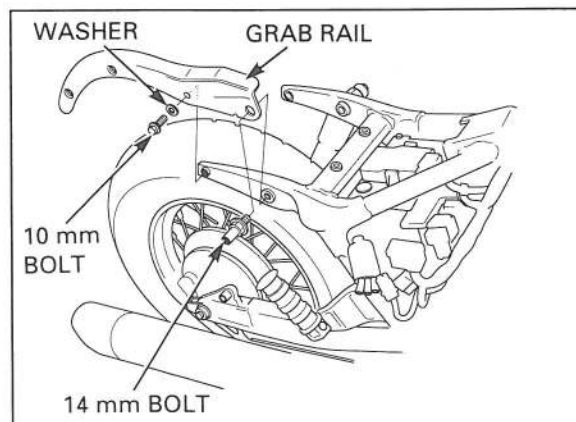

EXHAUST PIPE/MUFFLER

⚠ WARNING

Do not service the exhaust system while it is hot.

CAUTION:

When removing/installing the exhaust pipe/muffler, loosen/tighten the exhaust system fasteners in the order as follows.

REMOVAL

Remove the exhaust pipe joint nuts

Remove the muffler bracket nuts and exhaust pipe/muffler assembly.

Remove the front and rear gaskets.

Remove the exhaust pipe joint collar.

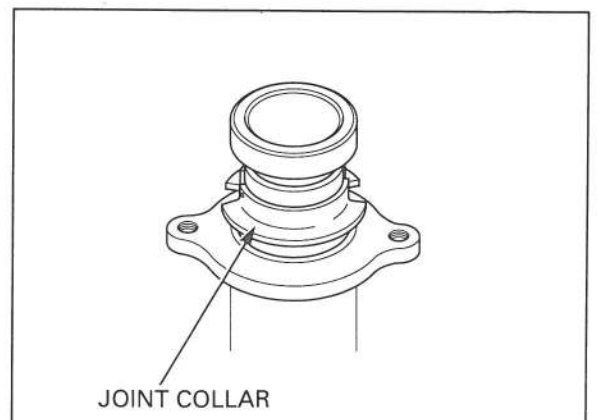
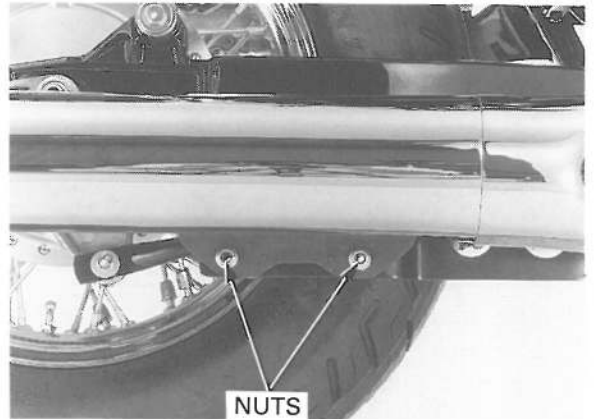
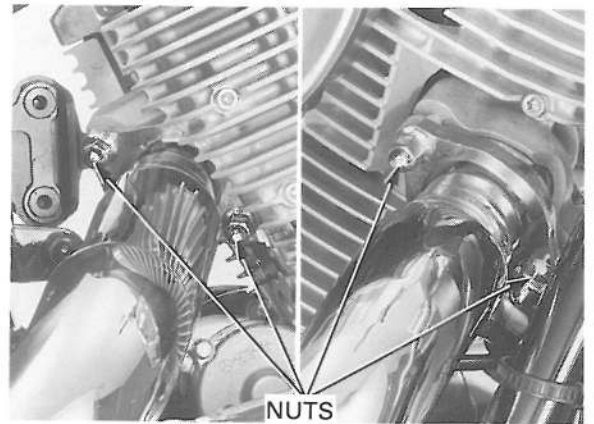

FRAME/BODY PANELS/EXHAUST SYSTEM

The exhaust pipe protectors can be removed without removing the exhaust system from the engine.

Drive the exhaust pipe protector using the plastic hammer and break the lock tab (reverse side of the protector) and remove it.

Do not reuse the removed protector.

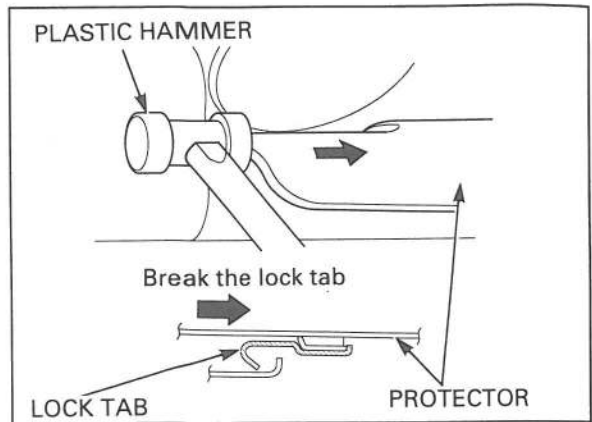

INSTALLATION

Install the exhaust pipe protectors.

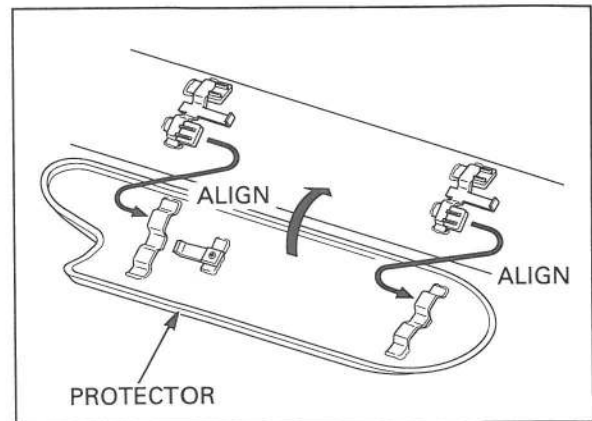

Install the exhaust pipe joint collar.

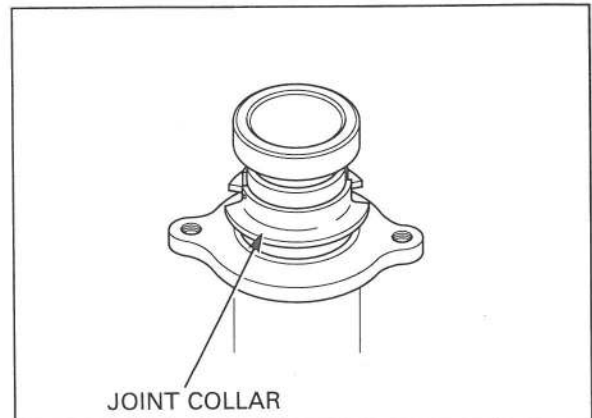

Install the new gaskets.

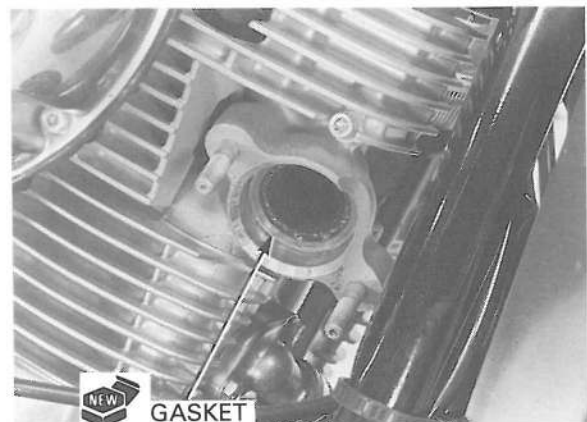

Install the muffler assembly.
Temporarily install the all nuts.

NOTE:

Do not tighten the nuts yet.

Tighten the muffler bracket nuts to the specified torque.

TORQUE: 26 N·m (2.7 kgf·m, 20 lbf·ft)

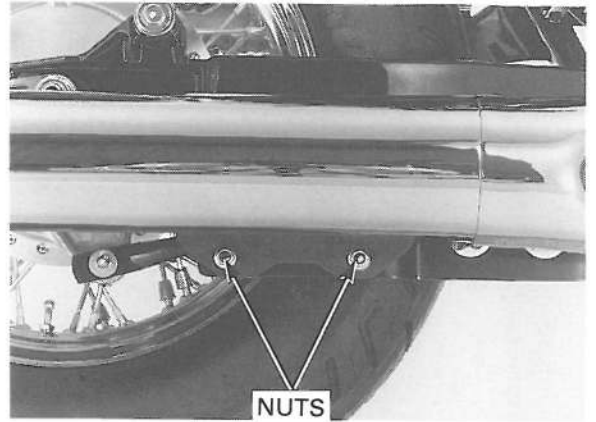

Always inspect the exhaust system for leaks after installation.

Tighten the exhaust pipe joint nuts to the specified torque.

TORQUE: 25 N·m (2.5 kgf·m, 18 lbf·ft)

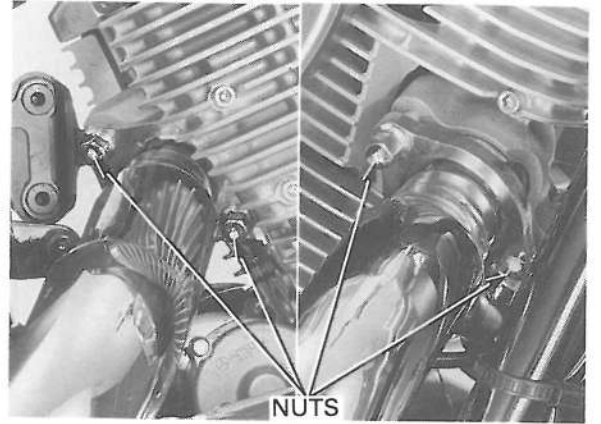

MEMO



3. MAINTENANCE

SERVICE INFORMATION	3-1	EVAPORATIVE EMISSION CONTROL SYSTEM (CALIFORNIA TYPE ONLY)	3-17
MAINTENANCE SCHEDULE	3-3	DRIVE CHAIN	3-18
FUEL LINE	3-4	BRAKE FLUID	3-22
THROTTLE OPERATION	3-4	BRAKE SHOE/PAD WEAR	3-23
CARBURETOR CHOKE	3-5	BRAKE SYSTEM	3-23
AIR CLEANER	3-6	BRAKE LIGHT SWITCH	3-25
CRANKCASE BREATHER	3-7	HEADLIGHT AIM	3-25
SPARK PLUG	3-7	CLUTCH SYSTEM	3-26
VALVE CLEARANCE	3-9	SIDE STAND	3-26
ENGINE OIL/OIL FILTER	3-11	SUSPENSION	3-27
CARBURETOR SYNCHRONIZATION	3-14	NUTS, BOLTS, FASTENERS	3-27
ENGINE IDLE SPEED	3-15	WHEELS/TIRES	3-28
RADIATOR COOLANT	3-16	STEERING HEAD BEARINGS	3-29
COOLING SYSTEM	3-16		

SERVICE INFORMATION

GENERAL

⚠ WARNING

- Gasoline is extremely flammable and is explosive under certain conditions. Work in a well ventilated area. Smoking or allowing flames or sparks in the work area or where the gasoline is stored can cause a fire or explosion.
- If the engine must be running to do some work, make sure the area is well ventilated. Never run the engine in an enclosed area. The exhaust contains poisonous carbon monoxide gas that may cause loss of consciousness and may lead to death. Run the engine in an open area or with an exhaust evacuation system in enclosed area.

- Place the motorcycle on a level ground before starting any work.

SPECIFICATIONS

ITEM		SPECIFICATIONS	
Throttle grip free play		2 – 6 mm (1/12 – 1/4 in)	
Spark plug		NGK	DENSO
	Standard	DPR8EA 9	X24EPR-U9
	For cold climate (below 5°C/41°F)	DPR7EA 9	X22EPR-U9
	For extend high speed riding	DPR9EA 9	X27EPR-U9
Spark plug gap		0.80 – 0.90 mm (0.031 – 0.035 in)	
Valve clearance	IN	0.13 – 0.17 mm (0.005 – 0.007 in)	
	EX	0.18 – 0.22 mm (0.007 – 0.009 in)	

MAINTENANCE

ITEM		SPECIFICATIONS	
Engine oil capacity	at draining	2.2 liter (2.32 US qt, 1.94 Imp qt)	
	at disassembly	2.9 liter (3.06 US qt, 2.55 Imp qt)	
	at oil filter change	2.4 liter (2.54 US qt, 2.11 Imp qt)	
Recommended engine oil		HONDA GN4 4-stroke oil or equivalent motor oil API service classification SF or SG Viscosity: SAE 10W-40	
Engine idle speed		1,000 ± 100 rpm	
Carburetor vacuum difference		27kPa (20 mm Hg, 0.7 in Hg)	
Drive chain slack		15 – 25 mm (3/5 – 1 in)	
Drive chain link		122L	
Drive chain size	DID	525V8	
	RK	525 SM5	
Brake pedal height		50 mm (2.0 in) above the top of the footpeg	
Brake pedal free play		20 – 30 mm (3/4 – 1-1/4 in)	
Recommended brake fluid		DOT 4	
Clutch lever free play		10 – 20 mm (3/8 – 3/4 in)	
Tire size	Front	120/90-17 64S	
	Rear	170/80-15 M/C 77S	
Tire brand	Bridgestone	Front	G701
		Rear	G702
	Dunlop	Front	D404F
		Rear	D404
Tire air pressure	Up to 90 kg (200 lb) load	Front	200 kPa (2.00 kgf/cm ² , 29 psi)
		Rear	200 kPa (2.00 kgf/cm ² , 29 psi)
	Up to maximum weight capacity	Front	200 kPa (2.00 kgf/cm ² , 29 psi)
		Rear	250 kPa (2.50 kgf/cm ² , 36 psi)
Minimum tire tread depth	Front	1.5 mm (0.06 in)	
	Rear	2.0 mm (0.08 in)	

TORQUE VALUES

Air cleaner housing cover bolt	2 N•m (0.2 kgf•m, 1.4 lbf•ft)	
Spark plug	12 N•m (1.2 kgf•m, 9 lbf•ft)	
Crankshaft hole cap	15 N•m (1.5 kgf•m, 11 lbf•ft)	Apply grease to the threads
Timing hole cap	15 N•m (1.5 kgf•m, 11 lbf•ft)	Apply grease to the threads
Valve adjusting screw lock nut	23 N•m (2.3 kgf•m, 17 lbf•ft)	Apply oil to the threads and seating surface
Oil drain bolt	34 N•m (3.5 kgf•m, 25 lbf•ft)	
Oil filter cartridge	10 N•m (1.0 kgf•m, 7 lbf•ft)	Apply oil to the threads and O-ring
Vacuum plug	3 N•m (0.3 kgf•m, 2.2 lbf•ft)	
Rear axle nut	88 N•m (9.0 kgf•m, 65 lbf•ft)	U-nut
Spoke nipple	4 N•m (0.4 kgf•m, 2.9 lbf•ft)	
Side stand assembly	34 N•m (3.5 kgf•m, 25 lbf•ft)	
Side stand pivot bolt	10 N•m (1.0 kgf•m, 7 lbf•ft)	
lock nut	29 N•m (3.0 kgf•m, 22 lbf•ft)	
Brake pedal stopper lock nut	10 N•m (1.0 kgf•m, 7 lbf•ft)	

TOOLS

Valve adjusting wrench	07908-KE90000	or 07908-KE90100 (U.S.A. only)
Vacuum gauge attachment	07510-3000200	or 07LMJ-001000A (U.S.A. only)
Oil filter wrench	07HAA-PJ70100	
Drive chain tool set	07HMH-MR10103	or 07HMH-MR7010B (U.S.A. only)
Spoke wrench	07JMA-MR60100	or equivalent commercially available in U.S.A.

MAINTENANCE SCHEDULE

Perform the Pre-ride inspection in the Owner's Manual at each scheduled maintenance period.

I: Inspect and Clean, Adjust, Lubricate or Replace if necessary. C: Clean. R: Replace. A: Adjust. L: Lubricate.

The following items require some mechanical knowledge. Certain items (particularly those marked * and **) may require more technical information and tools. Consult your authorized HONDA dealer.

ITEMS		FREQUENCY	ODOMETER READING (NOTE 1)								REFER TO PAGE								
			X1,000 mi		0.6		4		8			12		16		20		24	
			X100 km	10	64	128	192	256	320	384									
EMISSION RELATED ITEMS	* FUEL LINE					I			I				I					3-4	
	* THROTTLE OPERATION					I			I				I					3-4	
	* CARBURETOR CHOKE					I			I				I					3-5	
	AIR CLEANER	NOTE 2							R								R	3-6	
	CRANKCASE BREATHER	NOTE 3			C	C	C	C	C	C	C	C	C	C	C	C	C	3-7	
	SPARK PLUG				I	R	I	R	I	R	I	R	I	R	I	R	I	3-7	
	* VALVE CLEARANCE				I		I		I		I		I		I		I	3-9	
	ENGINE OIL				R		R		R		R		R		R		R	3-11	
	ENGINE OIL FILTER				R		R		R		R		R		R		R	3-11	
	* CARBURETOR SYNCHRONIZATION						I		I		I		I		I		I	3-14	
	* ENGINE IDLE SPEED				I	I	I	I	I	I	I	I	I	I	I	I	I	I	3-15
	RADIATOR COOLANT	NOTE 4					I		I		I		I		R		I	3-16	
	* COOLING SYSTEM						I		I		I		I		I		I	3-16	
* EVAPORATIVE EMISSION CONTROL SYSTEM	NOTE 5							I				I				I	3-17		
NON-EMISSION RELATED ITEMS	DRIVE CHAIN		EVERY 500 mi (800 km) I, L															3-18	
	BRAKE FLUID	NOTE 4				I	I	R	I	I	R	I	I	R	I	I	R	3-22	
	BRAKE SHOE/BRAKE PAD WEAR					I	I	I	I	I	I	I	I	I	I	I	I	3-23	
	BRAKE SYSTEM					I		I		I		I		I		I		3-23	
	* BRAKE LIGHT SWITCH							I		I		I		I		I		3-25	
	* HEADLIGHT AIM							I		I		I		I		I		3-25	
	CLUTCH SYSTEM					I	I	I	I	I	I	I	I	I	I	I	I	3-26	
	SIDE STAND							I		I		I		I		I		3-26	
	* SUSPENSION							I		I		I		I		I		3-27	
	* NUTS, BOLTS, FASTENERS					I		I		I		I		I		I		3-27	
	** WHEELS/TIRES					I	I	I	I	I	I	I	I	I	I	I	I	3-28	
** STEERING HEAD BEARINGS					I		I		I		I		I		I		3-29		

* Should be serviced by an authorized HONDA dealer, unless the owner has proper tools and service data and is mechanically qualified.

** In the interest of safety, we recommend these items be serviced only by an authorized HONDA dealer.

- NOTES:
1. At higher odometer reading, repeat at frequency interval established here.
 2. Service more frequently when riding in unusually wet or dusty areas.
 3. Service more frequently when riding in rain or at full throttle.
 4. Replace every 2 years, or at indicated odometer interval, whichever comes first. Replacement requires mechanical skill.
 5. California type only.

FUEL LINE

Remove the left side cover (page 2-4).

Check the fuel lines for deterioration, damage or leakage.

Replace the fuel lines if necessary.

Also check the fuel valve vacuum tube for damage. Replace the vacuum tube if necessary.

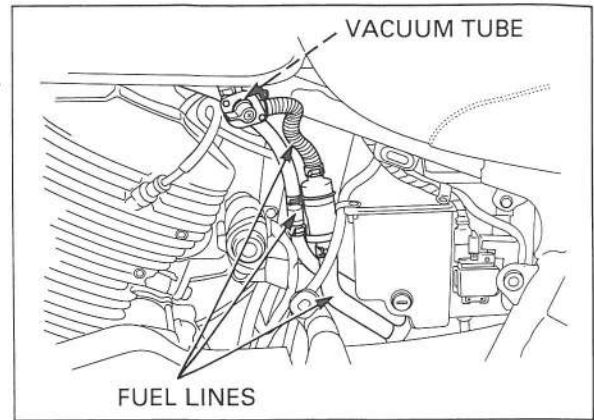

FUEL FILTER

Pull the fuel filter out, clip the inlet line closed and remove the filter.

Replace the fuel filter with new one, if necessary (page 5-28).

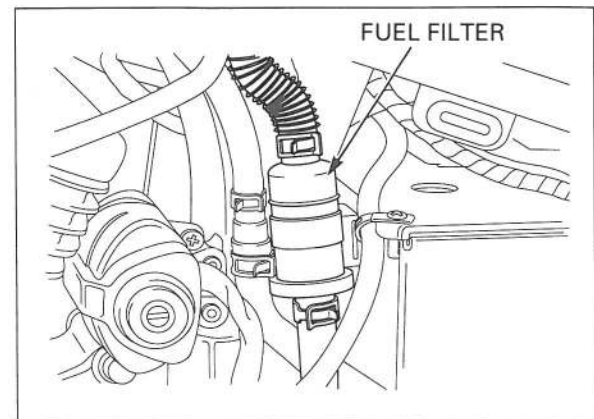

THROTTLE OPERATION

Check for any deterioration or damage to the throttle cables.

Check the throttle grip for smooth operation. Check that the throttle grip returns from the full open to the full closed position smoothly and automatically in all steering positions.

If the throttle grip does not return properly, lubricate the throttle cable, overhaul and lubricate the throttle grip housing.

For cable lubrication: Disconnect the throttle cables at their upper ends (page 13-8). Thoroughly lubricate the cables and their pivot points with a commercially available cable lubricant or a light weight oil.

If the throttle grip still does not return properly, replace the throttle cables.

⚠ WARNING

Reusing a damaged or abnormally bent or kinked throttle cable can prevent proper throttle side operation and may lead to a loss of throttle control while riding.

With the engine idling, turn the handlebar all the way to the right and left to ensure that idle speed does not change.

If idle speed increases, check the throttle grip free play and the throttle cable connection.

Measure the throttle grip free play at the throttle grip flange.

FREE PLAY: 2 – 6 mm (1/12 – 1/4 in)

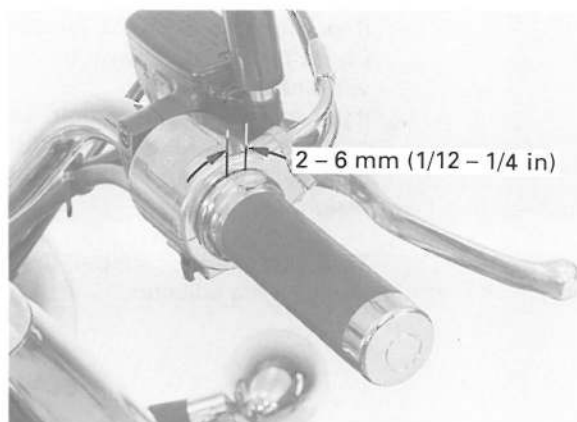

Throttle grip free play can be adjusted at either end of the throttle cable. Minor adjustments are made with the upper adjuster.

Loosen the lock nut and turn the adjuster to obtain the free play.

After the adjustment, tighten the lock nut securely and reposition the boot properly.

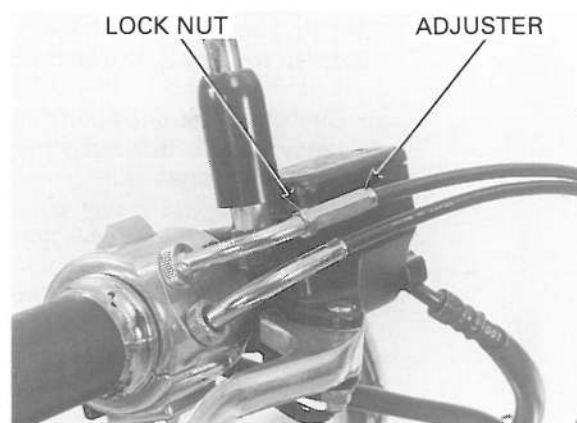

Major adjustments are made with the lower adjuster.

Loosen the lock nuts and turn the adjusters to obtain the free play.

Tighten the lock nuts after the adjustment has been made.

Recheck the free play.

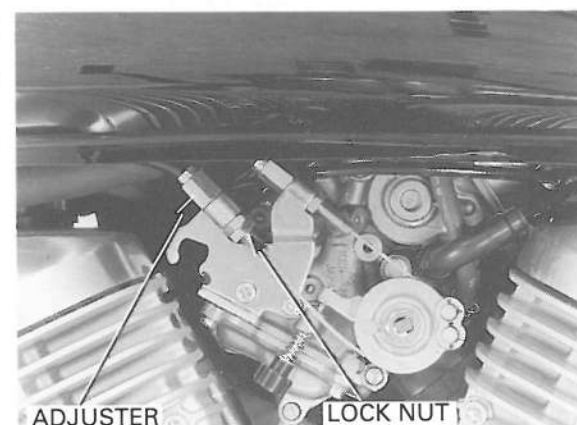

CARBURETOR CHOKE

STARTING ENRICHMENT (SE) VALVE

The choke system uses a fuel enriching circuit controlled by an SE valve. The SE valve opens the enriching circuit via a cable when the SE valve knob on the right side of the carburetor is pulled.

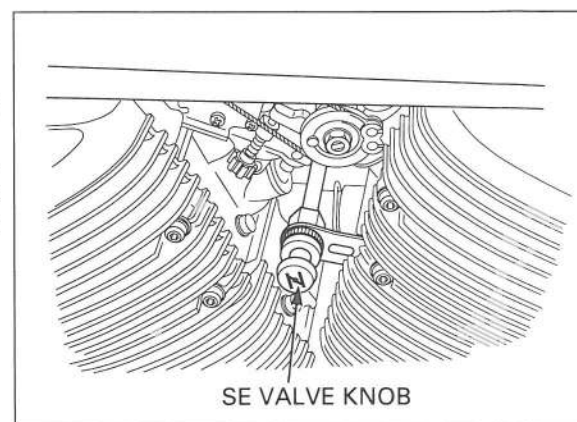

MAINTENANCE

Check for smooth operation of the SE valve knob. Check for any deterioration or damage to the SE valve cable.

If the operation is not smooth, lubricate the SE valve cable and SE valve knob sliding surface with a commercially available cable lubricant or a light weight oil.

To adjust the friction, pull the rubber cover away and turn the adjuster.

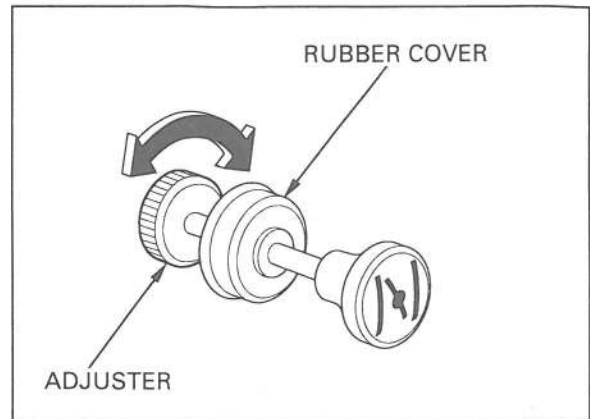

Starting enrichment system operation can be checked by the way the engine starts and runs:

- Difficulty in starting before the engine is warm up (easy once it is warmed up): SE valve is not completely opened.
- Idle speed is erratic even after warm-up (imperfect combustion): SE valve is not completely closed.

When the above symptoms occur, inspect the SE valve using the following procedure.

Remove the carburetor (page 5-8).

Loosen the SE valve nuts and remove them from the carburetors.

Pull the SE valve knob all the way out to fully open position and recheck for smooth operation of the SE valve knob.

There should be no free play.

Check valve seat on the SE valve for damage. Reinstall the SE valve in the reverse order of removal.

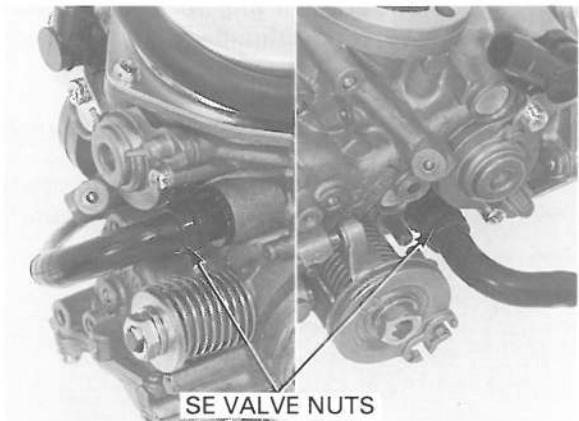

AIR CLEANER

NOTE:

- The viscous paper element type air cleaner cannot be cleaned because the element contains a dust adhesive.
- If the motorcycle is used in wet or dusty areas, more frequent inspections are required.

Remove the air cleaner housing cover bolts and cover.

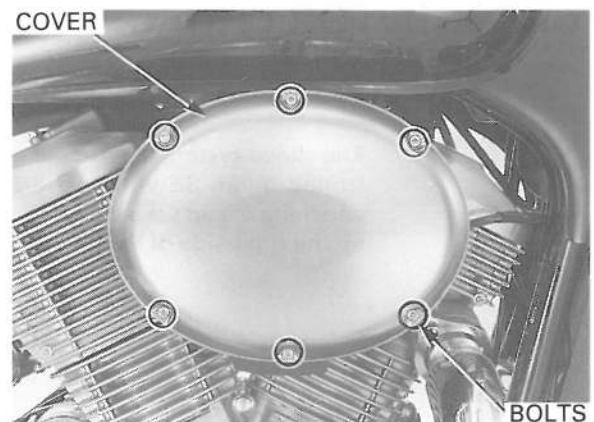

Remove the air cleaner element from the air cleaner housing.
 Replace the element accordance with the maintenance schedule.
 Also, replace the element any time it is excessively dirty or damaged.

Installation is in the reverse order of removal.

TORQUE:

Air cleaner housing cover bolt:
 2 N·m (0.2 kgf·m, 1.4 lbf·ft)

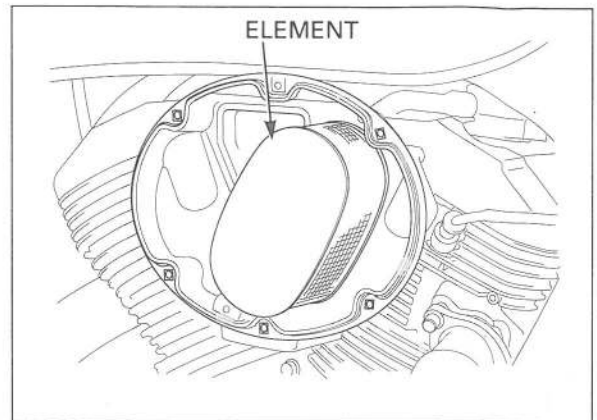

CRANKCASE BREATHER

NOTE:

Service more frequently when ridden in rain, at full throttle, or after the motorcycle is washed or overturned. Service if the deposits level can be seen in the transparent section of the breather tube.

The crankcase drain tube is behind the air cleaner housing.

Remove the drain tube from the air cleaner housing to empty any deposits.

Reinstall the drain tube.

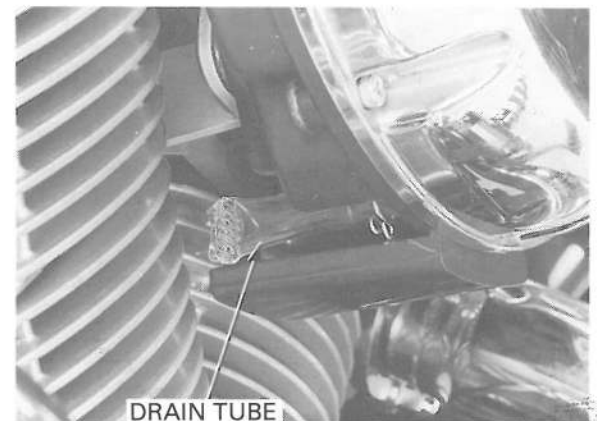

SPARK PLUG

Disconnect the spark plug caps.

NOTE:

Clean around the spark plug bases with compressed air before removing, and be sure that no debris is allowed to enter the combustion chamber.

Remove the spark plugs using the spark plug wrench or an equivalent.

Inspect or replace as described in the maintenance schedule (page 3-3).

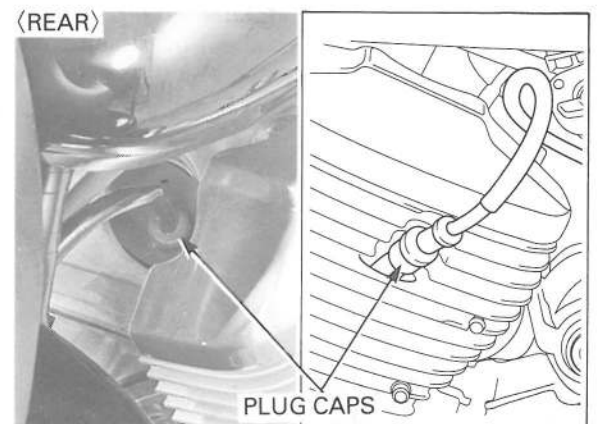
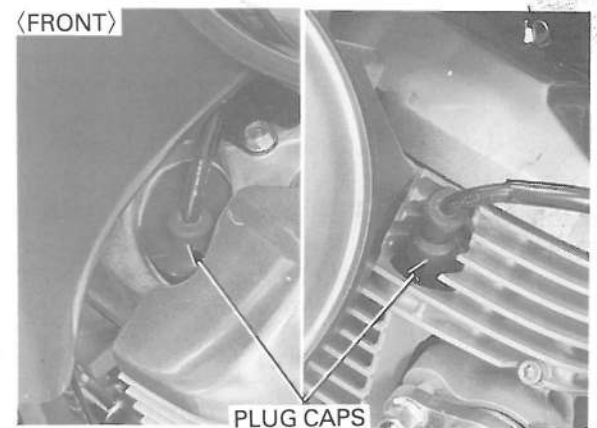

INSPECTION

Check the following and replace if necessary (recommended spark plugs: page 3-1).

- Insulator for damage.
- Electrodes for wear
- Burning condition, coloration;
 - dark to light brown indicates good condition.
 - excessive lightness indicates malfunctioning ignition system or lean mixture.
 - wet or black sooty deposit indicates over-rich mixture.

REUSING A SPARK PLUG

Clean the spark plug electrodes with a wire brush or spark plug cleaner.

Check the gap between the center and side electrodes with a wire-type feeler gauge. If necessary, adjust the gap by bending the side electrodes carefully.

SPARK PLUG GAP: 0.80 – 0.90 mm (0.031 – 0.035 in)

CAUTION:

To prevent damage to the cylinder head, hand-tighten the spark plug before using a wrench to tighten to the special torque.

Reinstall the spark plug in the cylinder head and hand tighten, then torque to specification.

TORQUE: 14 N·m (1.4 kgf·m, 10 lbf·ft)

REPLACING A SPARK PLUG

Set the plug gap to specification with a wire-type feeler gauge (see above).

CAUTION:

Do not overtighten the spark plug.

Install and hand tighten the new spark plug, then tighten it about 1/2 of a turn after the sealing washer contacts the seat of the plug hole.

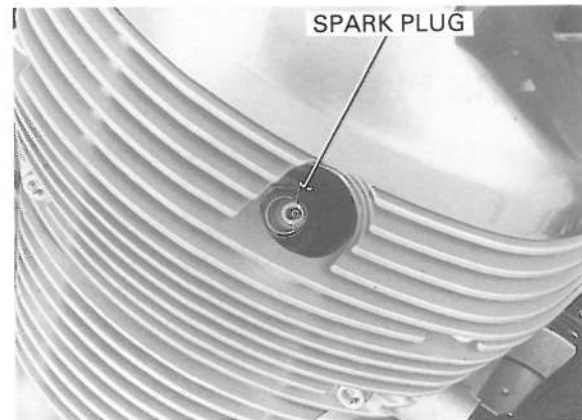
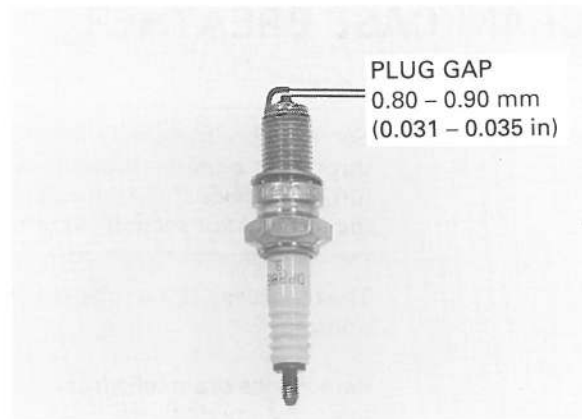
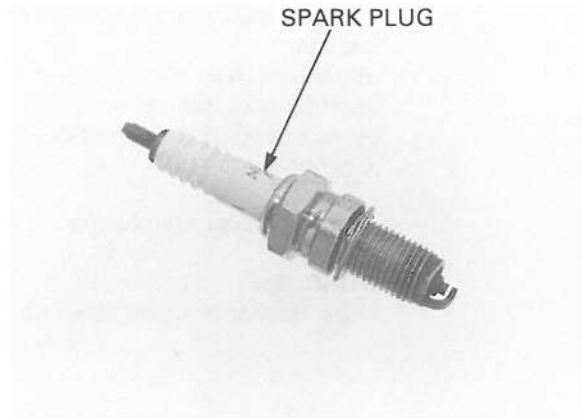

VALVE CLEARANCE

INSPECTION

NOTE:

Inspect and adjust the valve clearance while the engine is cold (below 35°C/95° F)

Remove the cylinder head covers (page 10-5).

Remove the crankshaft hole cap and timing hole cap.

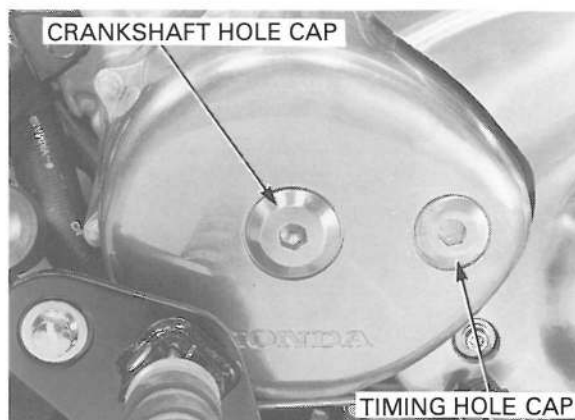

FRONT CYLINDER HEAD

Adjust the front cylinder valves first.

Rotate the flywheel counterclockwise to align the "FT" mark with the index notch on the left crankcase cover.

Make sure the piston is at TDC (Top Dead Center) on the compression stroke. The cam lobes will be facing down.

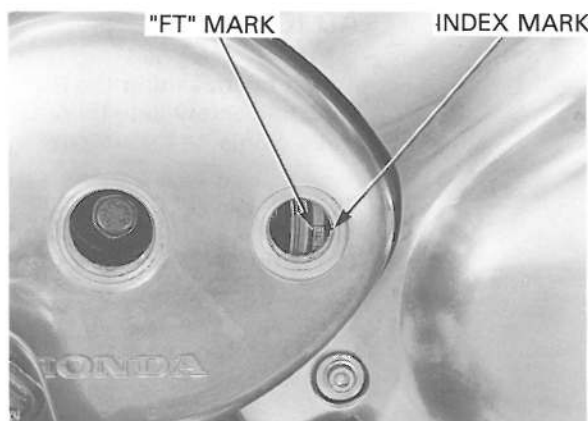

REAR CYLINDER HEAD

Rotate the flywheel counterclockwise to align the "RT" mark with the index notch on the left crankcase cover.

Make sure the piston is at TDC (Top Dead Center) on the compression stroke. The cam lobes will be facing down.

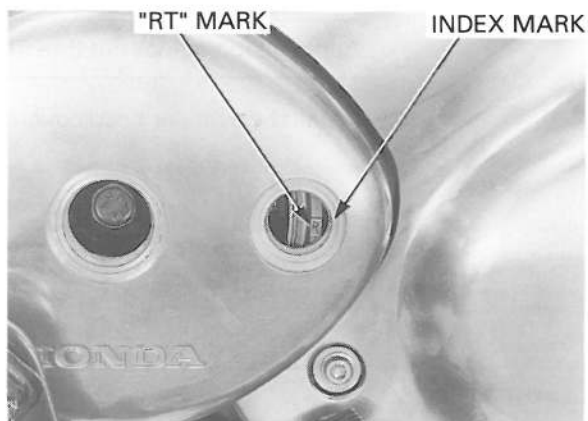

Inspect the clearance of all three valves by inserting a feeler gauge between the adjusting screw and the valve.

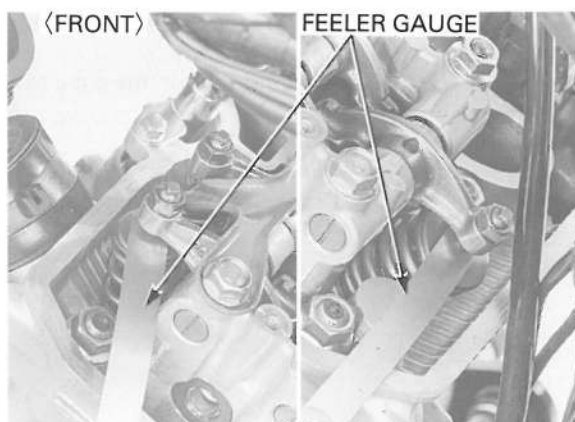

MAINTENANCE

VALVE CLEARANCE:

IN: 0.13 – 0.17 mm (0.005 – 0.007 in)

EX: 0.18 – 0.22 mm (0.007 – 0.009 in)

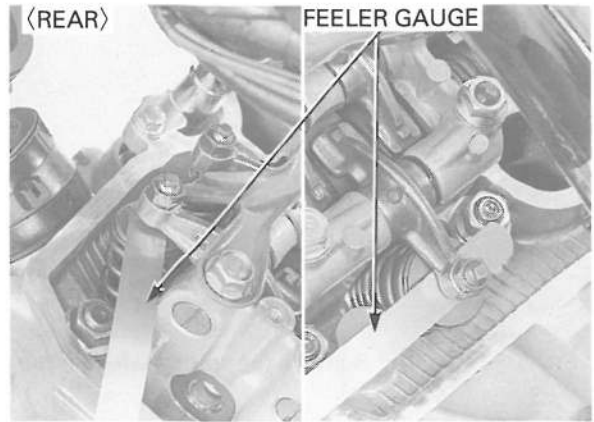

ADJUSTMENT

Adjust by loosening the lock nut and turning the adjusting screw until there is a slight drag on the feeler gauge.

Hold the adjusting screw and tighten the lock nut.

TORQUE: 23 N·m (2.3 kgf·m, 17 lbf·ft)

TOOL:

Valve adjusting wrench 07908-KE90000 or
07908-KE90100
(U.S.A. only)

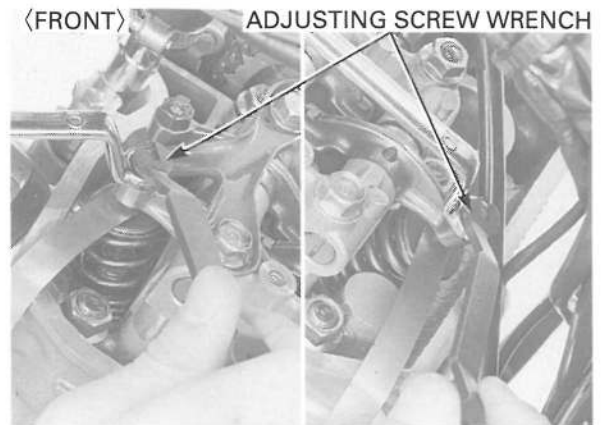

NOTE:

Apply oil to the lock nut threads.

Install the cylinder head covers (page 10-33).

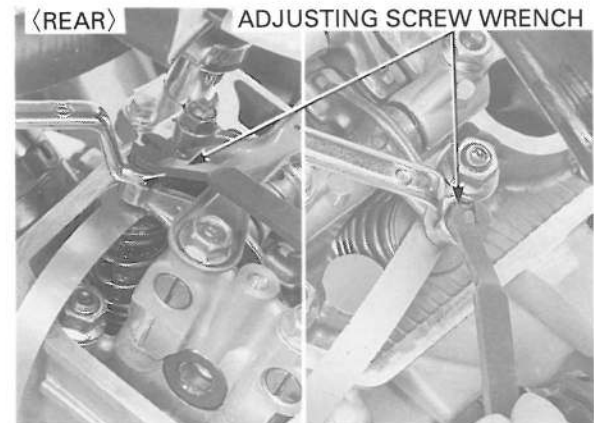

Apply grease to the timing hole cap and crankshaft hole cap threads.

Install and tighten the caps to the specified torque.

TORQUE:

Timing hole cap: 15 N·m (1.5 kgf·m, 11 lbf·ft)

Crankshaft hole cap: 15 N·m (1.5 kgf·m, 11 lbf·ft)

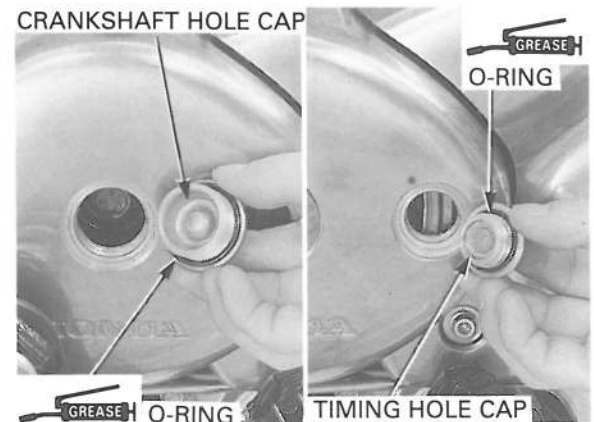

ENGINE OIL/OIL FILTER

OIL LEVEL INSPECTION

⚠ WARNING

- *If the engine must be running to do some work, make sure the area is well-ventilated. Never run the engine in an enclosed area. The exhaust contains poisonous carbon monoxide gas that may cause loss of consciousness and may lead to death.*
- *Engine and exhaust system parts become very hot and remain hot for sometime after the engine is run. Wear insulated gloves or wait until the engine and exhaust system have cooled before handling these parts.*

NOTE:

- Do not screw in the oil cap/level gauge when checking oil level.
- The oil level cannot be correctly measured if the motorcycle is not supported perfectly upright on a level surface.
- As the oil is gradually consumed, it is necessary to periodically check the oil level and replenish the oil volume to its proper level.
- If the oil level is too high, overall engine performance and the actuation of the clutch may be effected. Too little oil may cause engine overheating as well as premature wear to various parts.
- If a different brand or grade of oil or low quality oil is mixed when adding oil, the lubricating function deteriorates.

Support the motorcycle in an upright and level position using a hoist or a jack under the engine.

Start the engine and let it idle for a few minutes.
Stop the engine and wait 2 – 3 minutes.

Remove the oil filler cap/dipstick and wipe off the oil from the dipstick with a clean cloth.

With the motorcycle upright on level ground, insert the oil filler cap/dipstick into the stick hole without screwing it in.
Remove the oil filler cap/dipstick and check the oil level.

If the level is below or near the lower level mark on the dipstick, fill to the upper level mark with the recommended oil.

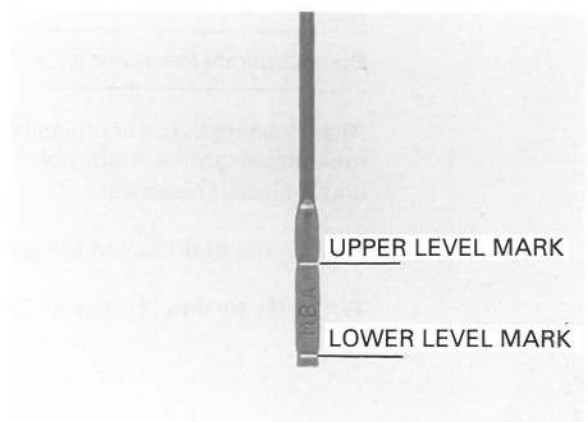
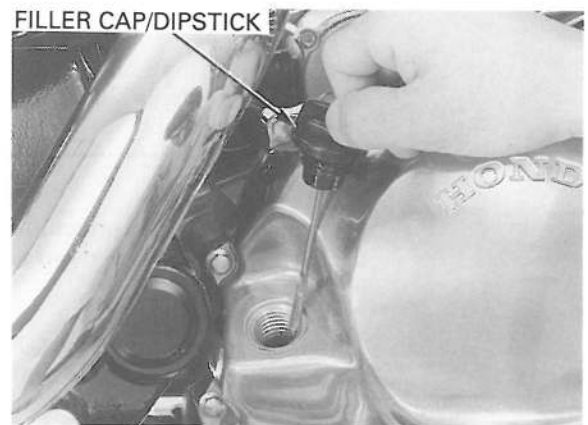

MAINTENANCE

RECOMMENDED ENGINE OIL:

HONDA GN4 4-stroke oil or equivalent motor oil
API service classification SF or SG
Viscosity: SAE 10W-40

NOTE:

Other viscosities shown in the chart may be used when the average temperature in your riding area is within the indicated range.

Check the O-ring for damage.

Reinstall the oil filler cap/dipstick.

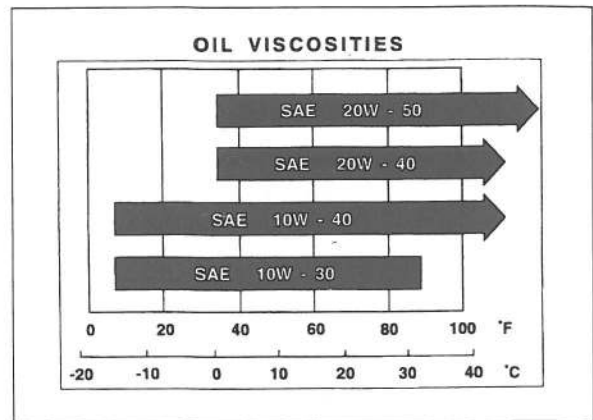

ENGINE OIL CHANGE

⚠ WARNING

- *If the engine must be running to do some work, make sure the area is well-ventilated. Never run the engine in an enclosed area. The exhaust contains poisonous carbon monoxide gas that may cause loss of consciousness and may lead to death.*
- *Engine and exhaust system parts become very hot and remain hot for sometime after the engine is run. Wear insulated gloves or wait until the engine and exhaust system have cooled before handling these parts.*

NOTE:

Change the engine oil with the engine warm and the motorcycle on its side stand to assure complete and rapid draining.

Warm up the engine.

Place an oil drain pan under the engine to catch the oil, then remove the oil drain bolt and oil filler cap/dipstick.

With the engine stop switch "OFF", push the starter button for a few seconds to drain any oil which may be left in the engine.

NOTE:

Do not operate the motor for more than few seconds.

After draining the oil completely, check that the sealing washer on the drain bolt is in good condition and replace if necessary.

Tighten the drain bolt to the specified torque.

TORQUE: 30 N·m (3.1 kgf·m, 22 lbf·ft)

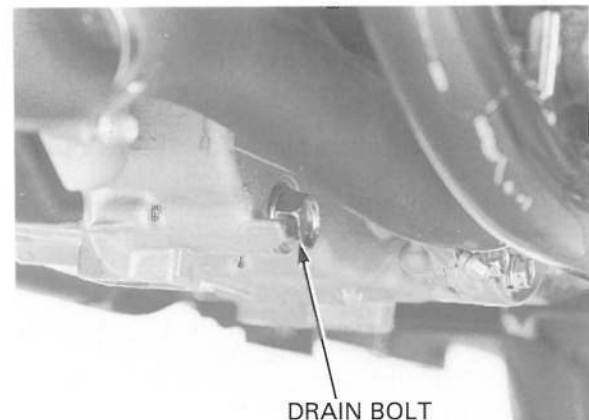
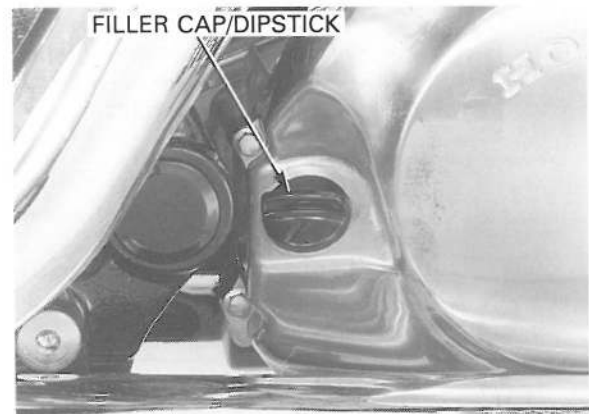
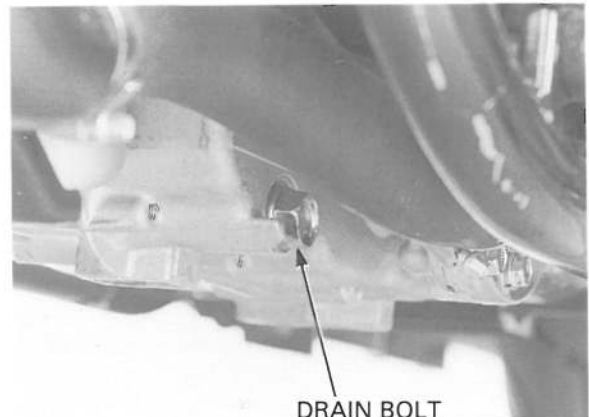

Fill the crankcase with the recommended engine oil.

OIL CAPACITY:

- 2.2 liter (2.32 US qt, 1.94 Imp qt) at draining
- 2.9 liter (3.06 US qt, 2.55 Imp qt) at disassembly
- 2.4 liter (2.54 US qt, 2.11 Imp qt) at oil filter change

Install the oil filter cap/dipstick.

Start the engine and let it idle for 2 or 3 minutes. Stop the engine and wait a few minutes, then check that the oil level is at the upper level mark with the motorcycle upright.

Check that there are no oil leaks.

OIL FILTER CHANGE

⚠ WARNING

- *If the engine must be running to do some work, make sure the area is well-ventilated. Never run the engine in an enclosed area. The exhaust contains poisonous carbon monoxide gas that may cause loss of consciousness and may lead to death.*
- *Engine and exhaust system parts become very hot and remain hot for sometime after the engine is run. Wear insulated gloves or wait until the engine and exhaust system have cooled before handling these parts.*

Drain the engine oil (page 3-12).

Remove the oil filter using the oil filter wrench.

TOOL:

Oil filter wrench **07HAA-PJ70100**

Apply oil to the new oil filter O-ring.

Apply oil to the new oil filter threads. Install and tighten the new oil filter to the specified torque.

TORQUE: 10 N·m (1.0 kgf·m, 7 lbf·ft)

Fill the crankcase with the recommended engine oil (page 3-12).

Install the oil filler cap/dipstick.

Start the engine and recheck the oil level (page 3-13).

Make sure that there are no oil leaks.

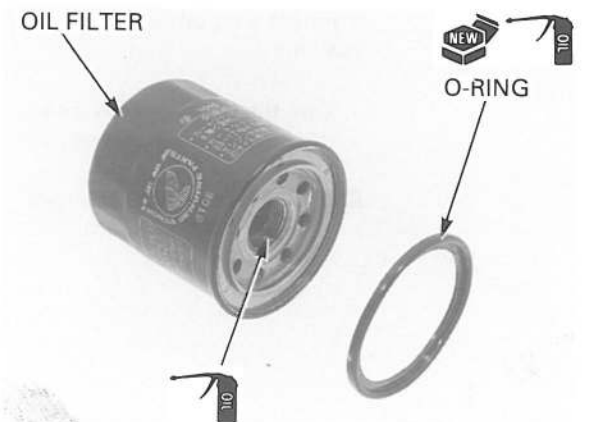
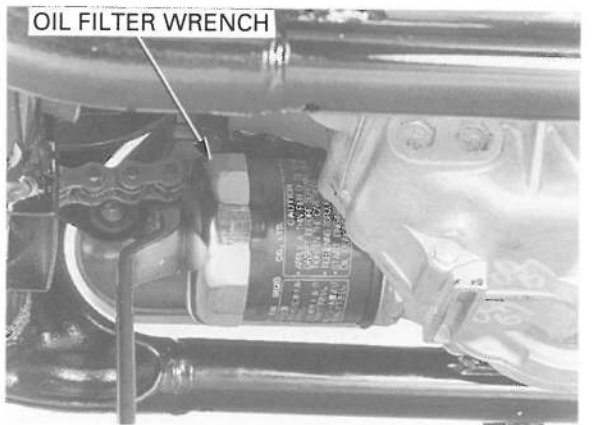
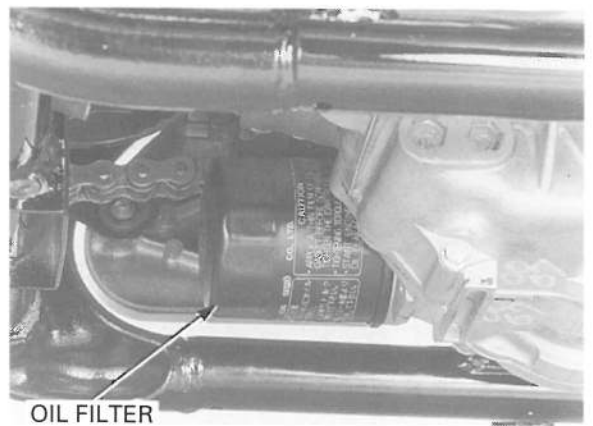
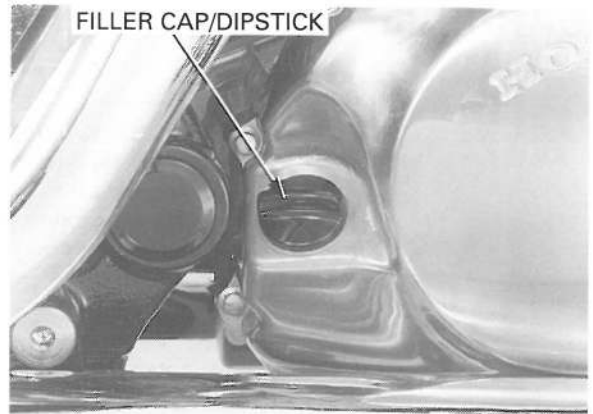

CARBURETOR SYNCHRONIZATION

⚠ WARNING

If the engine must be running to do some work, make sure the area is well-ventilated. Never run the engine in an enclosed area. The exhaust contains poisonous carbon monoxide gas that may cause loss of consciousness and may lead to death.

NOTE:

Perform this maintenance with the engine at normal operating temperature and transmission in neutral. Place the motorcycle on a level surface.

Remove the fuel tank mounting bolt. Carefully raise the tank and support it in the frame using a suitable base.

Remove the air cleaner housing (page 5-4).
Remove the rear cylinder head left side fin (page 10-7).

Remove the vacuum plugs and washers from the cylinder head intake ports.

Connect the vacuum gauge and adapters.

TOOL:

Vacuum gauge attachment 07510-3000200 or
07LMJ-001000A
(U.S.A. only)

Connect a suitable tube between the fuel tank and fuel line.

1. Turn the fuel valve ON. Start the engine and adjust the idle speed to the specification.

IDLE SPEED: 1,000 ± 100 rpm

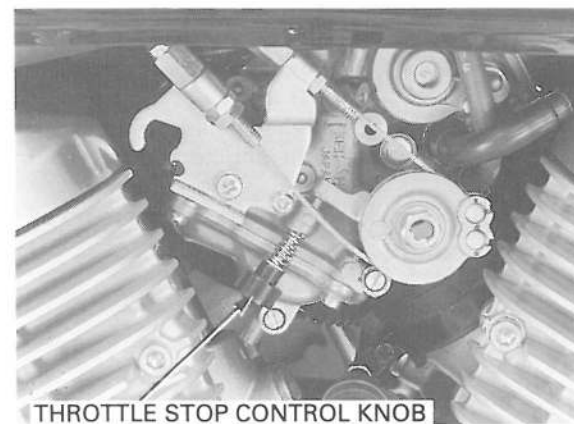
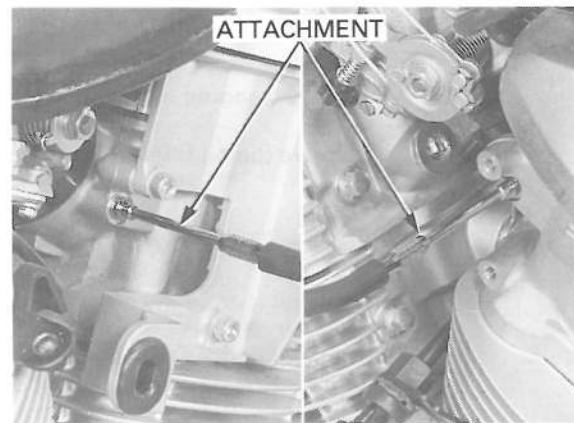
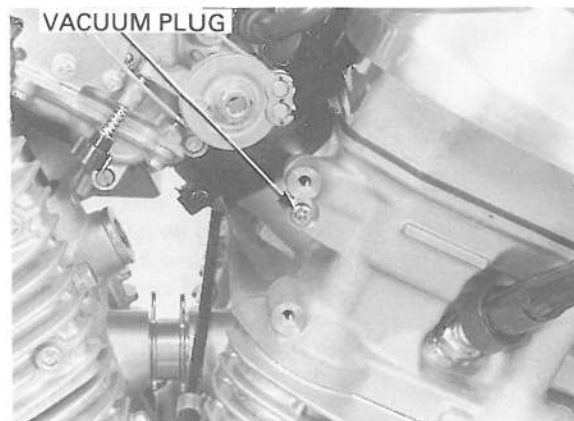
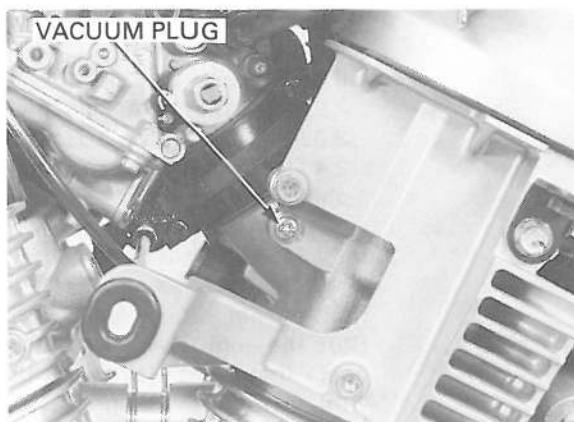

2. Check the difference in vacuum between each carburetor.

CARBURETOR VACUUM DIFFERENCE:
27 kPa (20 mm Hg, 0.7 in Hg)

NOTE:

The base carburetor is the Rear (No.1) carburetor.

3. Synchronize to specification by turning the adjusting screw.
4. Be sure that the synchronization is stable by snapping the throttle grip several times.
5. Snap the throttle grip several times and recheck the idle speed and difference in vacuum between each carburetor.

Disconnect the vacuum gauge and adapters.

Install the vacuum plugs and washers.
Tighten the plugs to the specified torque.

TORQUE: 3 N·m (0.3 kgf·m, 2.2 lbf·ft)

Install the rear cylinder head left side fin (page 10-36).

Install the air cleaner housing (page 5-4).

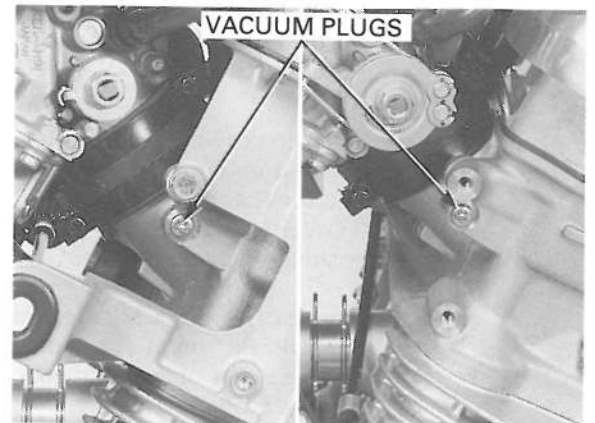
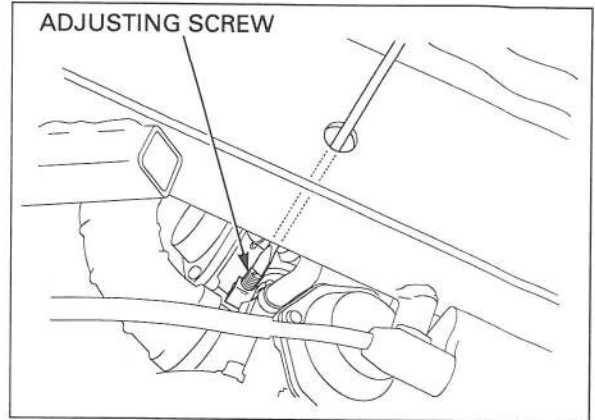

ENGINE IDLE SPEED

⚠ WARNING

If the engine must be running to do some work, make sure the area is well-ventilated. Never run the engine in an enclosed area. The exhaust contains poisonous carbon monoxide gas that may cause loss of consciousness and may lead to death.

NOTE:

- Perform this maintenance with the engine at normal operating temperature and transmission in neutral. Place the motorcycle on a level surface.
- Engine must be warm for accurate adjustment. Ten minutes of stop-and-go riding is sufficient.

Warm up the engine and shift the transmission into neutral.

Place the motorcycle on its side stand.

Check the idle speed and adjust by turning the throttle stop control knob if necessary.

IDLE SPEED: 1,000 ± 100 rpm

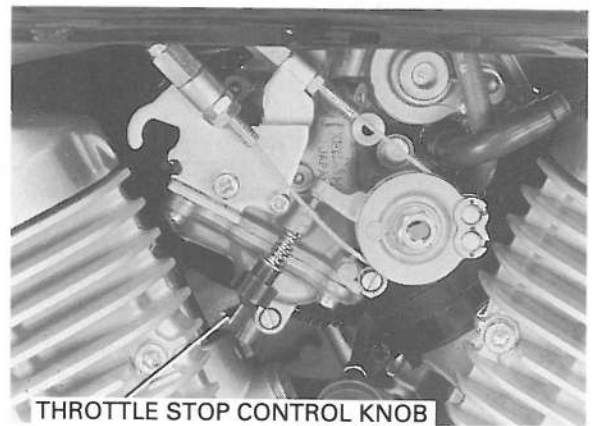

RADIATOR COOLANT

LEVEL CHECK

⚠ WARNING

- *Wait until the engine is cool before removing the radiator cap. Removing the cap while the engine is hot and the coolant is under pressure may cause serious scalding.*
- *Radiator coolant is poisonous. Take care to avoid getting coolant in your eyes, on your skin, or on your clothes.*
- *If coolant gets in your eyes, flush repeatedly with water and contact a doctor immediately.*
- *If coolant is accidentally swallowed, induce vomiting and contact a doctor immediately.*
- **KEEP OUT REACH OF CHILDREN.**

Check the coolant level of the reserve tank with the engine running at normal operating temperature. The level should be between the "UPPER" and "LOWER" level lines with the motorcycle in a vertical position on a flat, level surface.

If necessary, remove the reserve tank cap and fill to the "UPPER" level line with a 50-50 solution of distilled water and recommended antifreeze (coolant mixture preparation: page 6-4).

RECOMMENDED ANTIFREEZE :

Pro Honda HP Coolant or an equivalent high quality ethylene glycol antifreeze containing corrosion protection inhibitors

CAUTION:

Using coolant with silicate inhibitors may cause premature wear of water pump seals or blockage of radiator passages. Using tap water may cause engine damage.

Check to see if there are any coolant leaks when the coolant level decrease very rapidly.

If the reserve tank becomes completely empty, there is a possibility of air getting into the cooling system. Be sure to remove all air from the cooling system as described on page 6-5.

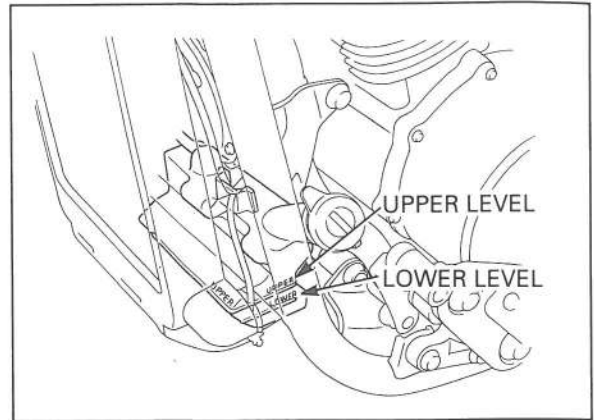

COOLING SYSTEM

⚠ WARNING

To prevent injury, keep your hands and clothing away from the cooling fan. It may start automatically, without warning.

Check the radiator air passage for clogging or damage.

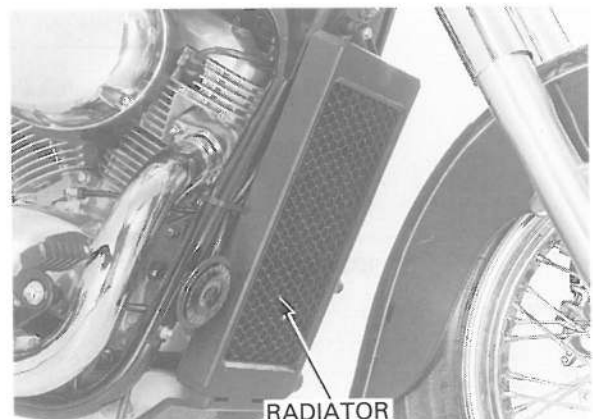

Straighten bent fins with a small, flat blade screwdriver and remove insects, mud or other obstructions with compressed air or low pressure water.
 Replace the radiator if the air flow is restricted over more than 20% of the radiating surface.
 For radiator replacement, refer to page 6-9.

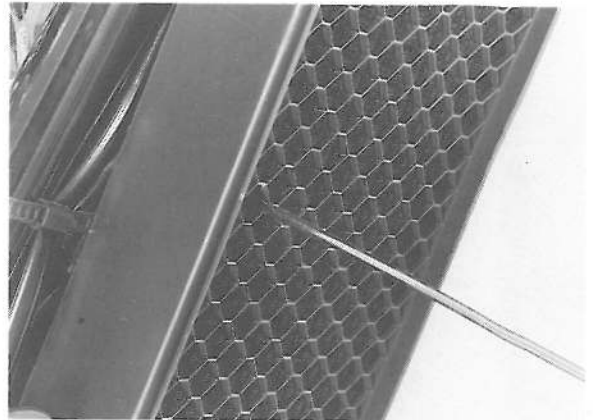

Remove the fuel tank and steering covers (section 2).

Check for any coolant leakage from the water pump, water hose and hose joints.
 Make sure the hoses are in good condition; they should not show any signs of deterioration.
 Replace any hose that shows any sign of deterioration.
 Check that all hose clamps are tight.

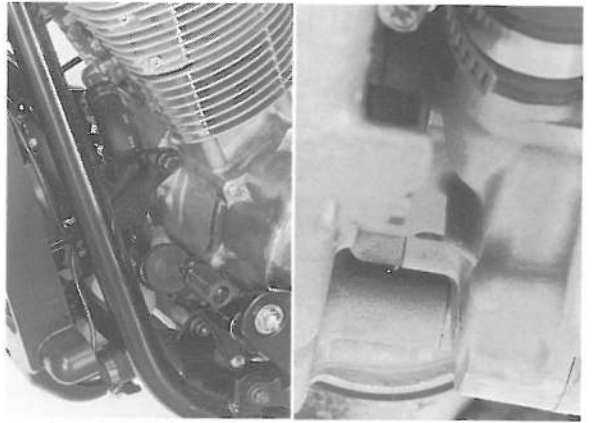

For radiator replacement, refer to 6-9.

EVAPORATIVE EMISSION CONTROL SYSTEM (CALIFORNIA TYPE ONLY)

Check the tube between the fuel tank, EVAP canister, EVAP purge control valve and carburetor for deterioration, damage or loose connection.

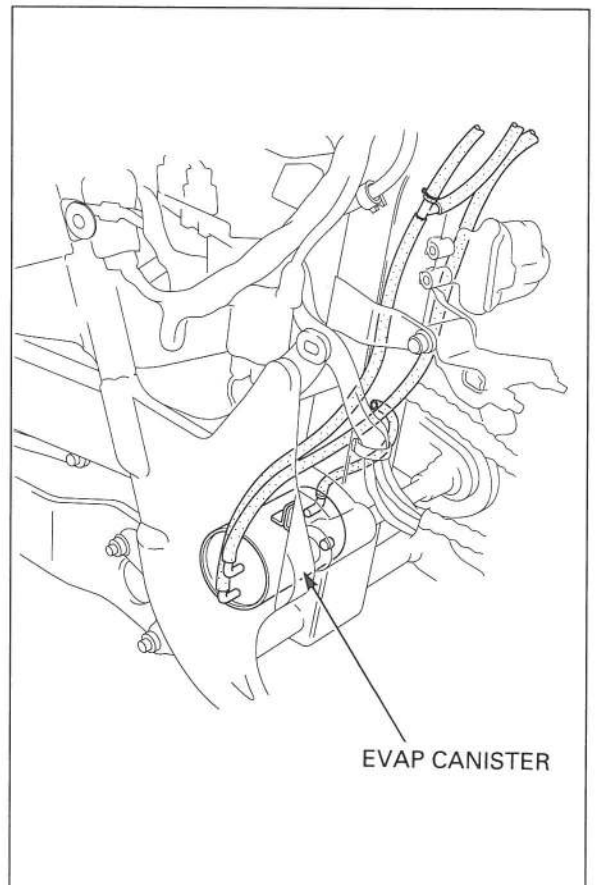

MAINTENANCE

Check the EVAP canister for cracks or other damage. Refer to the Vacuum Hose Routing Diagram Label and Cable & Harness Routing (page 1-33, 36) for tube connections.

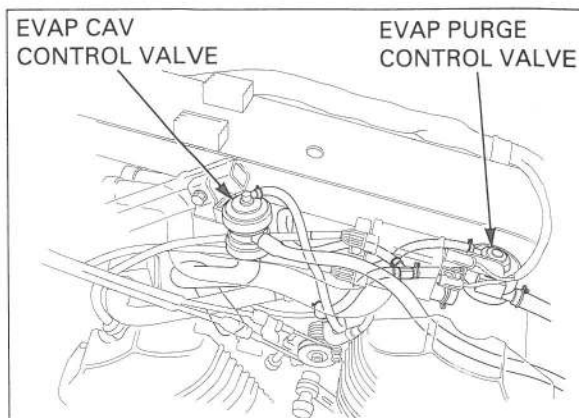

DRIVE CHAIN

DRIVE CHAIN SLACK INSPECTION

⚠ WARNING

Inspecting the drive chain while the engine is running can result in serious hand or finger injury.

Turn the ignition switch OFF, place the motorcycle on its side stand and shift the transmission in neutral.

Check the slack in the drive chain lower run midway between the sprockets.

DRIVE CHAIN SLACK: 15 – 25 mm (3/5 – 1 in)

CAUTION:

Excessive chain slack, 40 mm (1-3/5 in) or more, may damage the frame.

Lubricate the drive chain with #80 – 90 gear oil or drive chain lubricant designed specifically for use with O-ring chains. Wipe off the excess chain lube.

ADJUSTMENT

CAUTION:

If the adjustment is not the same, the wheel is out of alignment and can cause excessive tire, sprocket and chain wear.

Loosen the rear axle nut.

Turn both adjusting bolts until the correct drive chain slack is obtained.

Make sure the index marks on the both adjusters are aligned with the index marks of the swingarm. Tighten the rear axle nut to the specified torque.

TORQUE: 88 N·m (9.0 kgf·m, 65 lbf·ft)

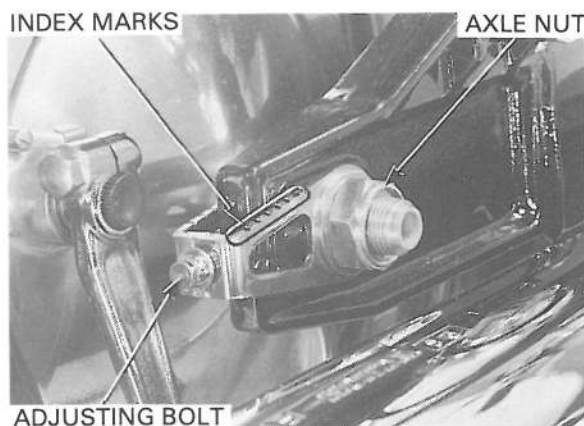
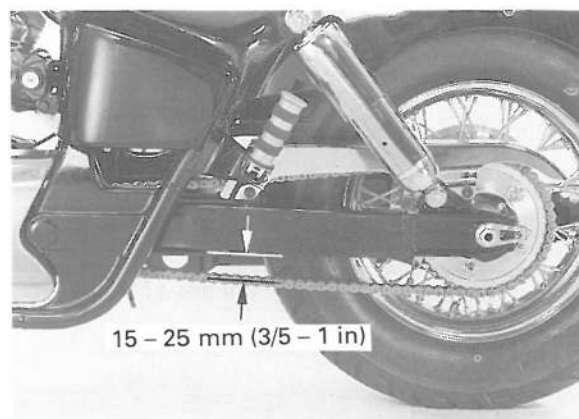

Recheck the drive chain slack and free wheel rotation.

Lubricate the drive chain with #80 – 90 gear oil or drive chain lubricant designed specifically for use with O-ring chains. Wipe off the excess chain lube. Check the drive chain wear indicator label attached on the left drive chain adjuster.

If the red zone of the indicator label reaches the end of the swingarm, replace the drive chain with a new one (page 3-20).

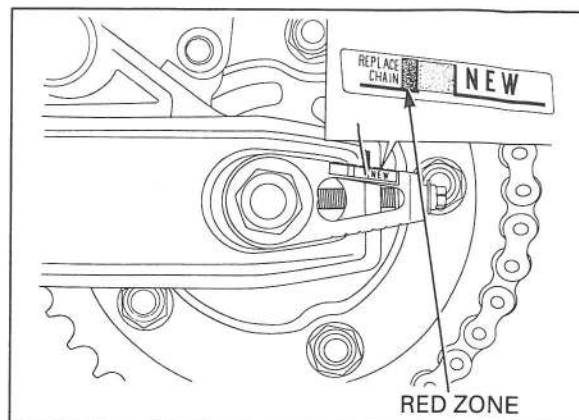

CLEANING, INSPECTION AND LUBRICATION

CAUTION:

- *Chains with O-rings should not be treated to the following cleaning and oiling procedure. This treatment will cause degradation of the O-rings and loss of grease, thus shortening chain life.*
- *Do not use steam or high pressure water washing. Use a chain spray containing a cleaning agent or use gasoline to clean the chain.*

Clean the chain with non flammable or high flash point solvent and wipe it dry.

Be sure the chain has dried completely before lubricating.

Inspect the drive chain for possible damage or wear. Replace any chain that has damaged rollers, loose fitting links, or other wise appears unserviceable. Installing a new chain on badly worn sprockets will cause the new chain to wear quickly. Inspect and replace sprockets as necessary.

Lubricate the drive chain with #80 – 90 gear oil or drive chain lubricant. Wipe off the excess chain lube.

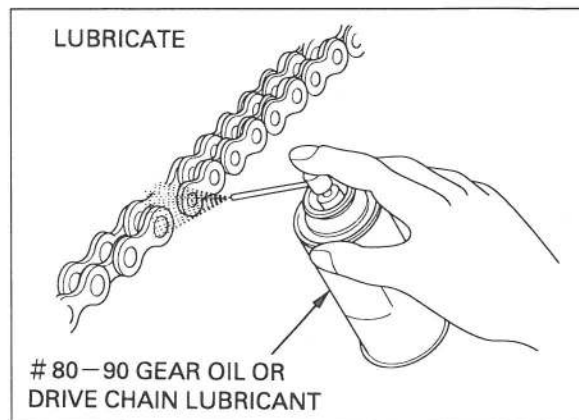
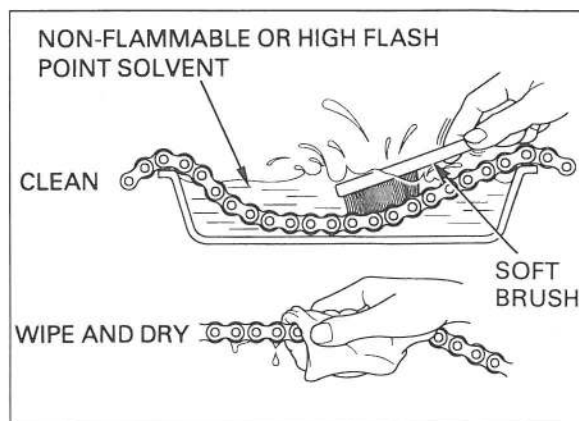

SPROCKETS INSPECTION

Inspect the drive and driven sprocket teeth for damage or wear. Replace if necessary.

Never use a new drive chain on worn sprockets. Both chain and sprockets must be in good condition, or the new replacement chain will wear rapidly.

Check the attachment bolts and nuts on the drive and driven sprockets.

If any are loose, torque them.

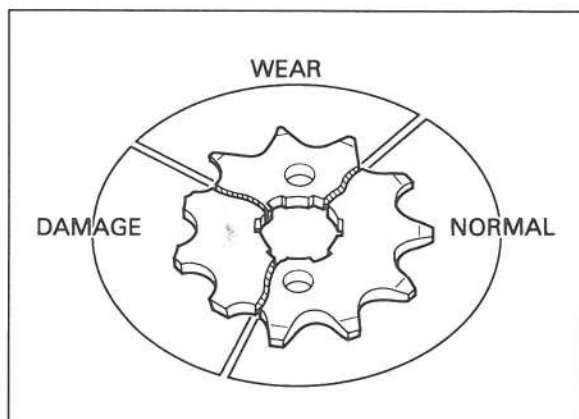

REPLACEMENT

CAUTION:

Because of the drive chain is master link joint pin staking type (the ends of the pins are expanded with the special tool), the specified types of chain and special tool must be used to replace. Do not use clip type chains.

This motorcycle uses a drive chain with a staked master link.

Loosen the drive chain (page 3-18).
Assemble the special tool.

When using the special tool, follow the manufacturer's operating instructions.

TOOL:

Drive chain tool set

07HMH-MR10103 or
07HMH-MR7010B
(U.S.A. only)

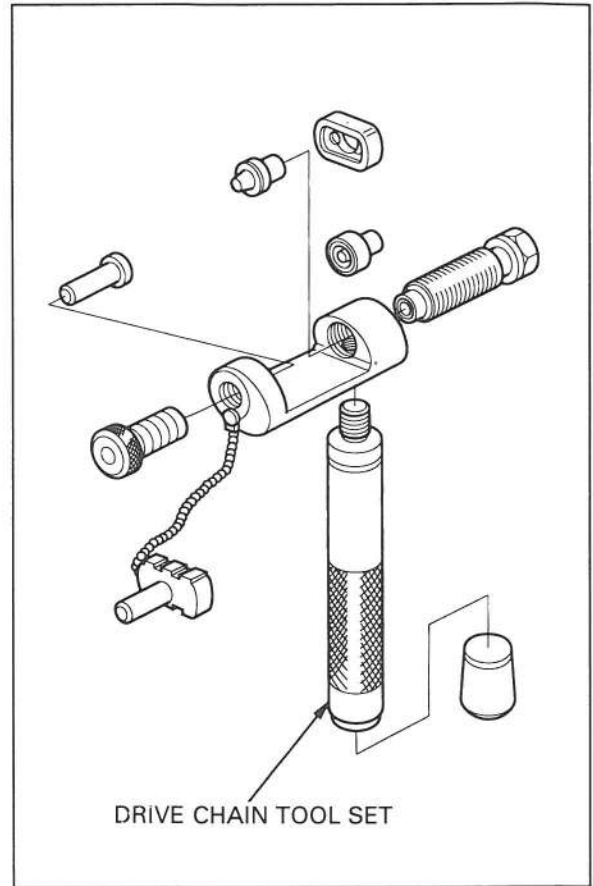

Locate the drive chain cutter on the staked part of the drive chain and cut the staked pins.

TOOL:

Drive chain tool set

07HMH-MR10103 or
07HMH-MR7010B
(U.S.A. only)

Remove the drive chain.

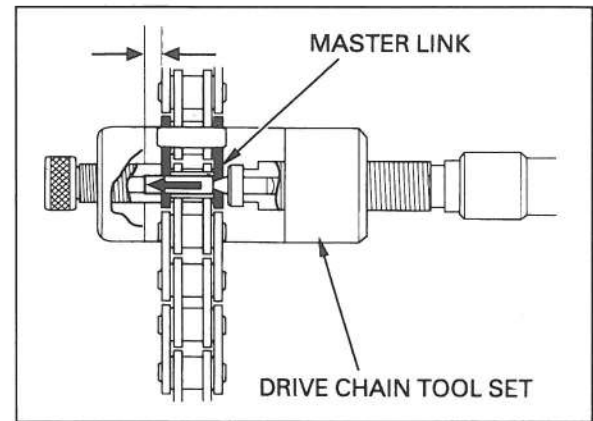

Remove the excess drive chain links from the new drive chain with the drive chain cutter.

NOTE:

- One (1) link is shown in the figure on the right.
- Include the master link when you count the drive chain links

Standard links: 122 links

Replacement chain: DID: 525 V8
RK: 525 SM5

Install the new drive chain over the swingarm.

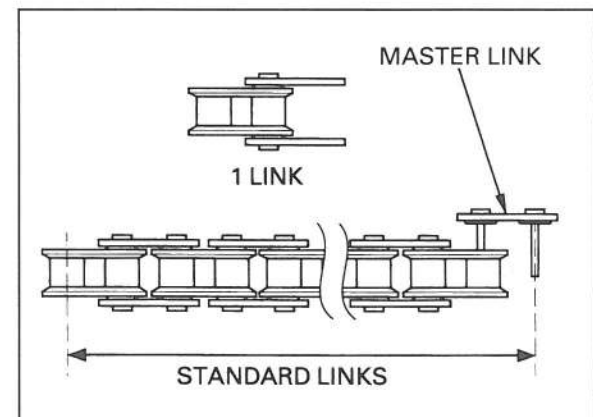

CAUTION:

Never reuse the old master link, master link plate and O-rings.

Install the new O-rings onto the new master link, and insert the master link from the inside of the drive chain taking care to prevent squeezing. Install the O-rings and the link plate with the drive chain cutter.

TOOL:

Drive chain tool set **07HMH-MR10103 or
07HMH-MR7010B
(U.S.A. only)**

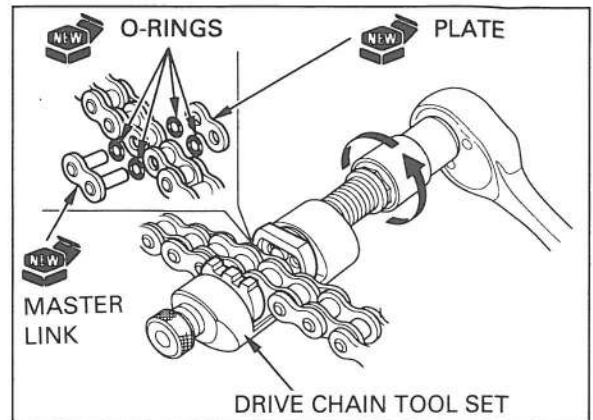

NOTE:

- Install the link plate with the identification mark facing the outside.
- Take care to prevent squeezing of the O-rings.
- Do not remove initially-applied grease from the link to lubricate.

Remove the special tool and check the master link pin length projected from the plate.

STANDARD LENGTH: 1.2 – 1.4 mm (0.05 – 0.06 in)

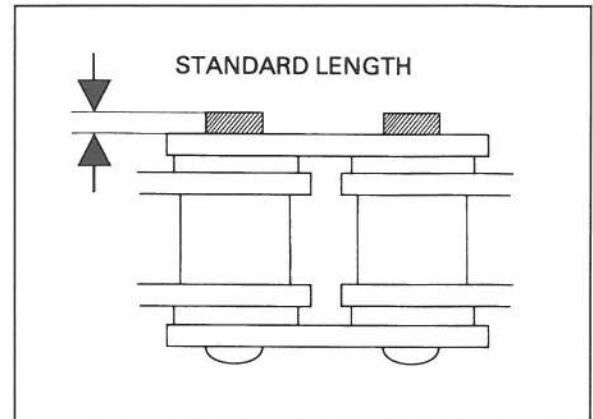

Install the drive chain cutter and stake the ends of the master link pins.

TOOL:

Drive chain tool set **07HMH-MR10103 or
07HMH-MR7010B
(U.S.A. only)**

NOTE:

To prevent overstaking, stake gradually checking the diameter of the staked area using a slide calipers.

After staking, check the staked area of the master link using a slide calipers.

**DIAMETER OF THE STAKED AREA:
5.50 – 5.80 mm (0.217 – 0.228 in)**

NOTE:

- When the measured staked area is over the prescribed value, restake using the new master link, plate and O-rings.
- When the measured staked area is below the prescribed value, reinstall the drive chain cutter and restake.

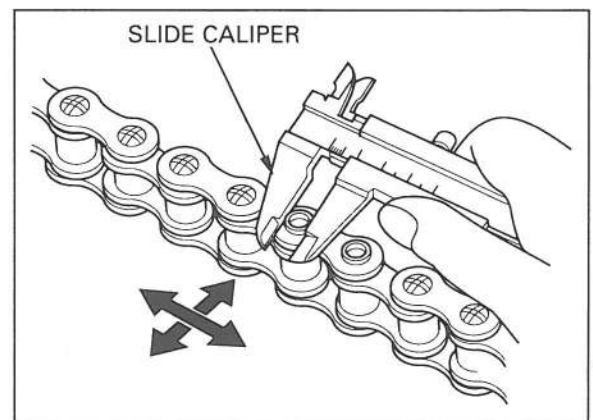
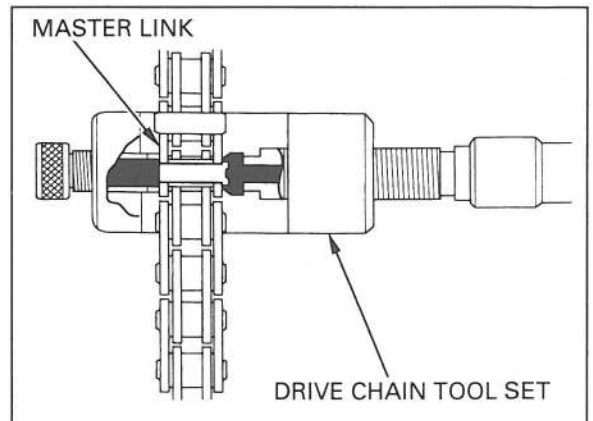

MAINTENANCE

Check the staked area of the master link for cracks and the O-rings for damages. If there is any cracking or damage, replace the master link, plate and O-ring.

CAUTION:

A drive chain with a clip-type master link must not be used.

Check that master link pivots freely on the pins. If the movement is not smooth, restake using the new master link, plate and O-rings.

Adjust the drive chain play.

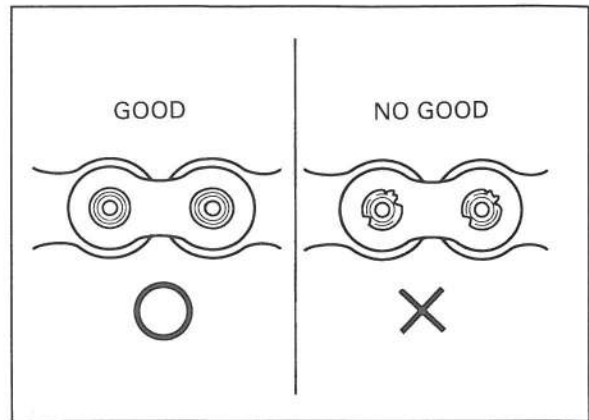

BRAKE FLUID

CAUTION:

- ***Do not remove the cover unless the reservoir is level because fluid may spill out.***
- ***Do not mix different types of fluid, as they are not compatible with each other.***
- ***Do not allow foreign material to enter the system when filling the reservoir.***
- ***Avoid spilling fluid on painted, plastic or rubber parts. Place a rug over these parts whenever the system is serviced.***

NOTE:

- When the fluid level is low, check the brake pads for wear (see next page). A low fluid level may be due to wear of the brake pads. If the brake pads are worn, the caliper piston is pushed out, and this accounts for a low reservoir level. If the brake pads are not worn and the fluid level is low, check entire system for leaks (page 3-23).
- Do not remove the level float from the reservoir when filling with brake fluid.

Turn the handlebar to the left side so that the reservoir is level and check the front brake reservoir level through the sight glass. If the level (float edge) is near the lower level mark, remove the cover, set plate and diaphragm and fill the reservoir to the casting ledge with DOT 4 brake fluid from a sealed container.

Refer to page 15-3 for brake fluid replacement/bleeding procedures.

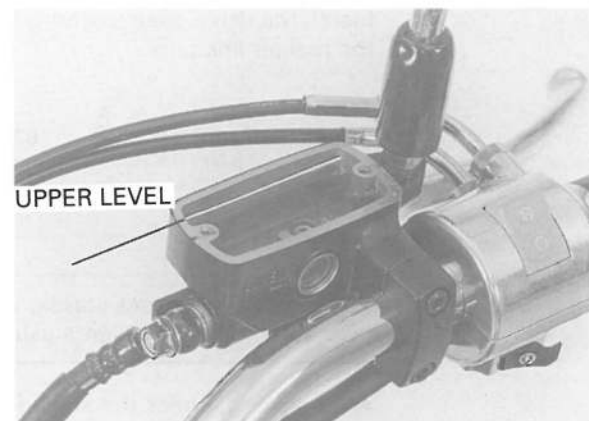

BRAKE SHOE/PAD WEAR

FRONT BRAKE PADS

Check the brake pad for wear.
 Replace the brake pads if either pad is worn to the bottom of wear limit groove.

Refer to page 15-5 for brake pad replacement.

CAUTION:

Always replace the brake pads as a set to assure even disc pressure.

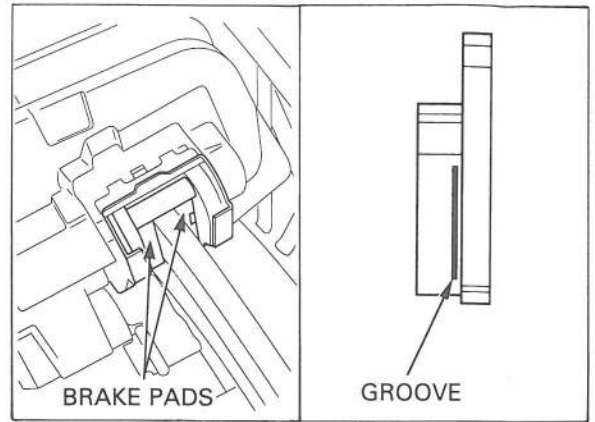

REAR BRAKE SHOE

Replace the brake shoes if the arrow on the brake arm aligns with the reference mark " Δ " on full application of the rear brake pedal.

Refer to page 14-12 for brake Shoe replacement.

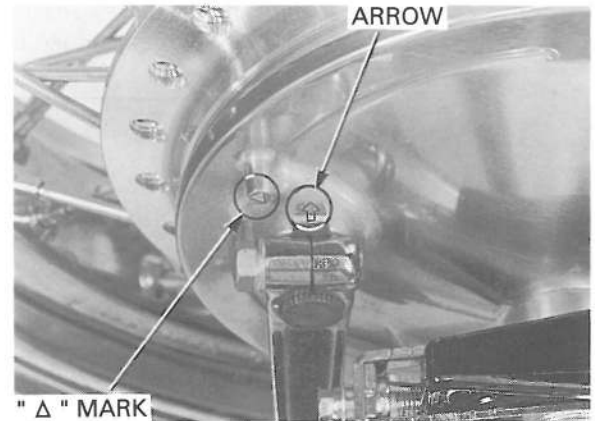

BRAKE SYSTEM

INSPECTION

Firmly apply the brake lever and check that no air has entered the system. If the lever feels soft or spongy when operated, bleed air from the system.

Inspect the brake hoses and fittings for deterioration, cracks and signs of leakage. Tighten any loose fittings.

Replace hoses and fittings as required.

Refer to page 15-3 for brake bleeding procedures.

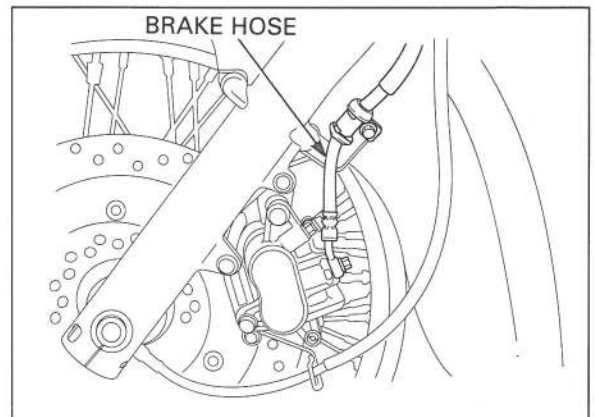
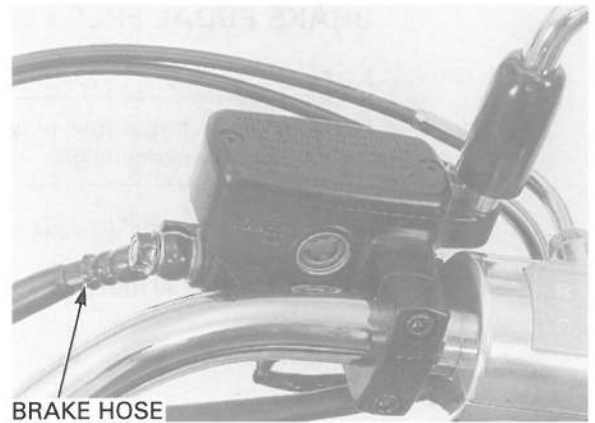

BRAKE PEDAL HEIGHT

Check the brake pedal height

BRAKE PEDAL HEIGHT:

50 mm (2.0 in) above the top of the footpeg

To adjust:

Loosen the stopper bolt lock nut and turn the stopper bolt.

Retighten the lock nut to the specified torque.

TORQUE: 10 N·m (1.0 kgf·m, 7 lbf·ft)

NOTE:

After adjusting the brake pedal height, check the rear brake light switch and brake pedal free play and adjust if necessary.

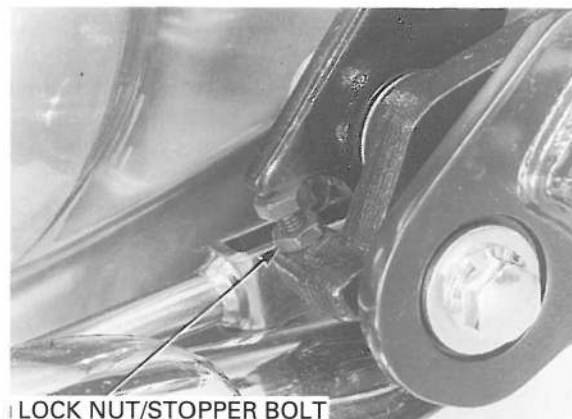
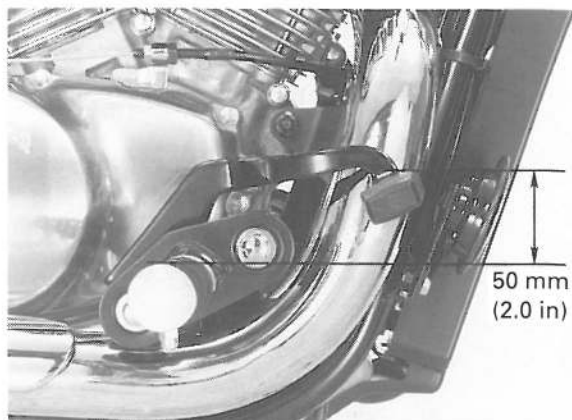

BRAKE PEDAL FREE PLAY

NOTE:

Perform brake pedal free play adjustment after adjusting brake pedal height.

Check the brake pedal free play.

FREE PLAY: 20 – 30 mm (3/4 – 1-1/4 in)

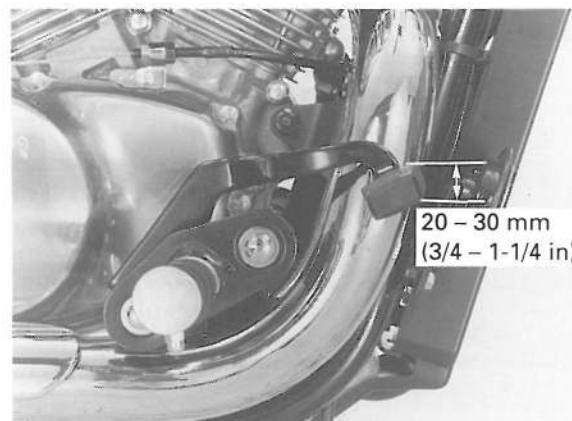

After adjusting the brake pedal free play, check the rear brake light switch operation and adjust if necessary.

If adjustment is necessary, use the rear brake adjusting nut.

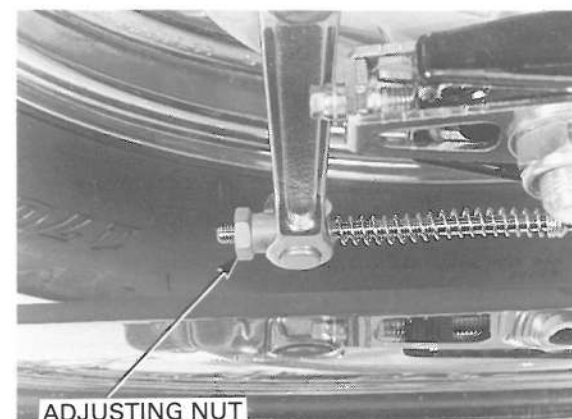

BRAKE LIGHT SWITCH

CAUTION:

Allowing the switch body to turn during adjustment can brake the wires in the switch.

NOTE:

- The brake light switch on the front brake lever cannot be adjusted. If the front brake light switch actuation and brake engagement are off, either replace the switch unit or the malfunctioning parts of the system.
- Make all rear brake light switch adjustments after the height adjustment and the brake pedal free play adjustment have been made.

Check the brake light switch operation and adjustment by applying the brakes. Visually inspect for any damage and make sure the reflector plate is clean within the light.

Adjust the rear brake light switch so that the brake light comes on just prior to come on, adjust the switch so that the light comes on at the proper time.

Turn the adjusting nut on the brake light switch and not the switch body and wires to make switch actuation adjustments.

Be sure to hold the switch body firmly while turning the adjusting nut.

Be sure to hold the switch body firmly while turning the adjusting nut.

After adjustment, recheck to be sure the brake light comes on at the proper time.

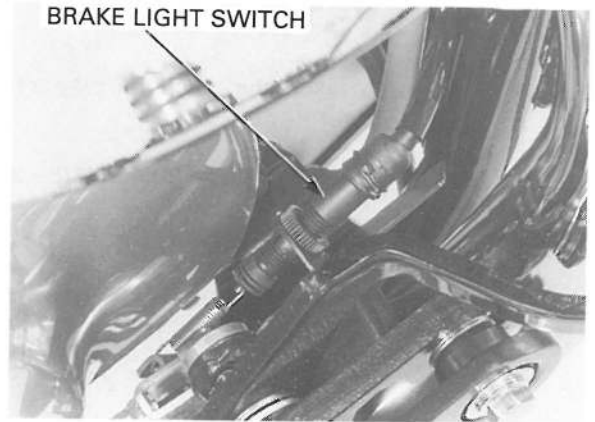

HEADLIGHT AIM

⚠ WARNING

An improperly adjusted headlight may blind oncoming drivers, or it may fail to light the road for a safe distance.

Adjust the headlight beam as specified by local laws and regulations.

Place the motorcycle on a level surface.

Adjust the headlight beam vertically turning the vertical beam adjusting screw.

A clockwise rotation moves the beam up.

Horizontally beam adjustment are made using the horizontal beam adjusting screw.

A clockwise rotation moves the beam toward the right side of the rider.

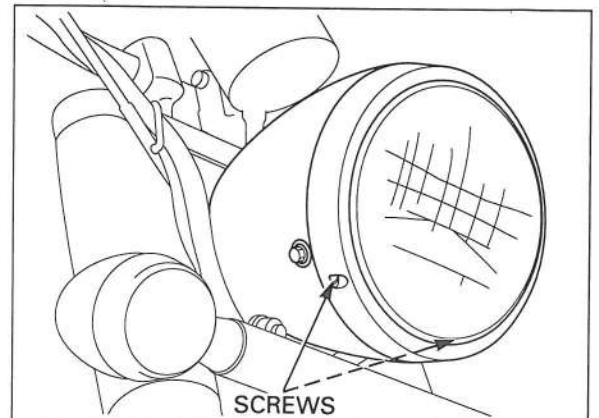

CLUTCH SYSTEM

Measure the clutch free play at the end of the clutch lever.

FREE PLAY: 10 – 20 mm (3/8 – 3/4 in)

Adjust as follows:

Minor adjustments are made at the adjuster near the lever.

Loosen the lock nut and turn the adjuster. Tighten the lock nut.

CAUTION:

The adjuster may be damaged if it is positioned too far out, leaving minimal thread engagement.

If the adjuster is threaded out near its limit and the correct free play cannot be obtained, turn the adjuster all the way in and back out one turn. Tighten the lock nut and make a major adjustment as described below.

Major adjustment is performed at the clutch arm. Loosen the lock nut and turn the adjusting nut to adjust free play. Hold the adjusting nut securely while tightening the lock nut.

If proper free play cannot be obtained, or the clutch slips during the test ride, disassemble and inspect the clutch (see section 8).

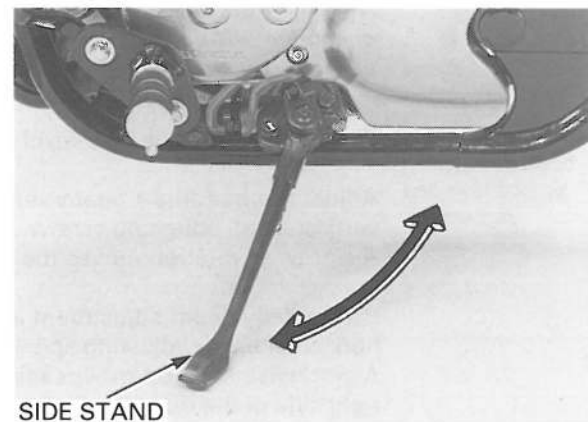
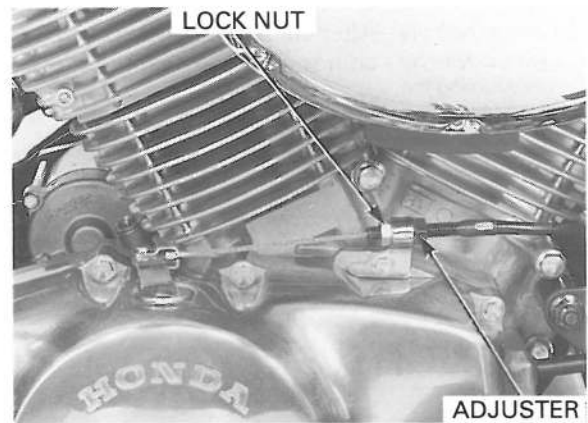
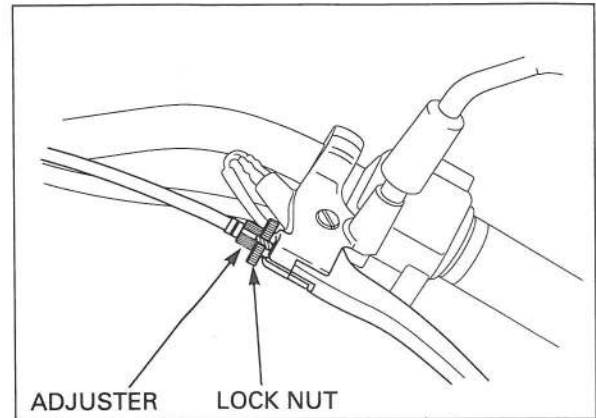
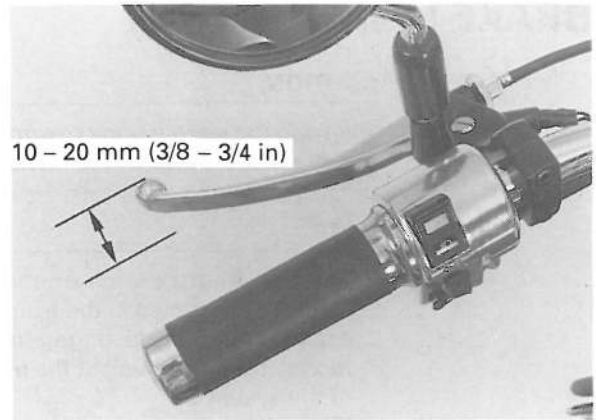

SIDE STAND

Support the motorcycle on a level surface.

Check the side stand spring for damage or loss of tension.

Check the side stand assembly for freedom of movement and lubricate the side stand pivot if necessary. Make sure that the side stand is not bent.

Check the side stand ignition cut-off system:

- Sit astride the motorcycle and raise the side stand.
- Start the engine with the transmission in neutral, then shift the transmission into gear, with the clutch lever squeezed.
- Move the side stand fully down.
- The engine should stop as the side stand is lowered.

If there is a problem with the system, check the side stand switch (section 19).

SUSPENSION

⚠ WARNING

Loose, worn, or damaged suspension parts impair motorcycle stability and control. Repair or replace any damaged components before riding. Riding a motorcycle with faulty suspension increases your risk of an accident and possible injury.

FRONT

Check the action of the fork by operating the front brake and compressing the front suspension several times.

Check the entire fork assembly for signs of leaks, damage or loose fasteners.

Replace damaged components which cannot be repaired.

Tighten all nuts and bolts.

Refer to section 13 for front fork service.

REAR

Support the motorcycle securely using a safety stand or hoist and raise the rear wheel off the ground.

Check for worn swingarm bearings by grabbing the rear wheel and attempting to move the wheel side to side.

Replace the bearings if any looseness is noted (section 14).

Check the action of the shock absorbers by compressing them several times.

Check the entire shock absorber assembly for signs of leaks, damage or loose fasteners.

Replace damaged components which cannot be repaired.

Tighten all nuts and bolts.

Refer to section 14 for shock absorber service.

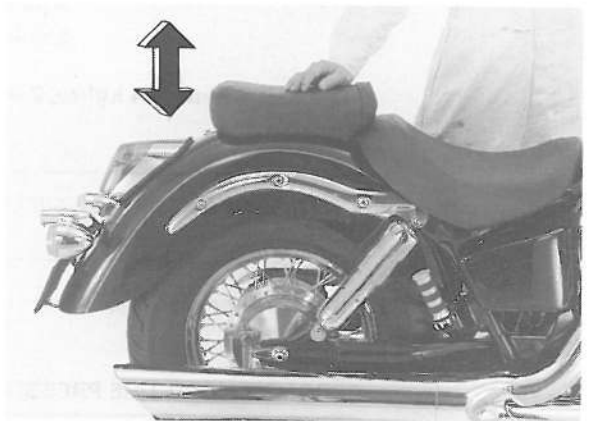
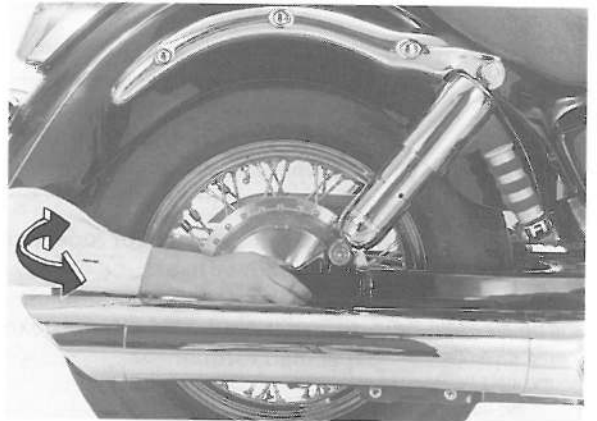
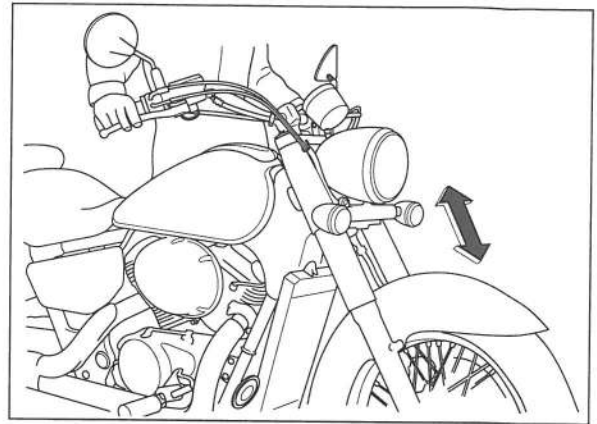

NUTS, BOLTS, FASTENERS

Check that all chassis nuts, bolts and screws are tightened to their correct torque values (page 1-13) at the interval shown in the Maintenance Schedule. Check that all cotter pins, slip clips, hose clamps and cable stays are in place and properly secured.

LUBRICATION SYSTEM

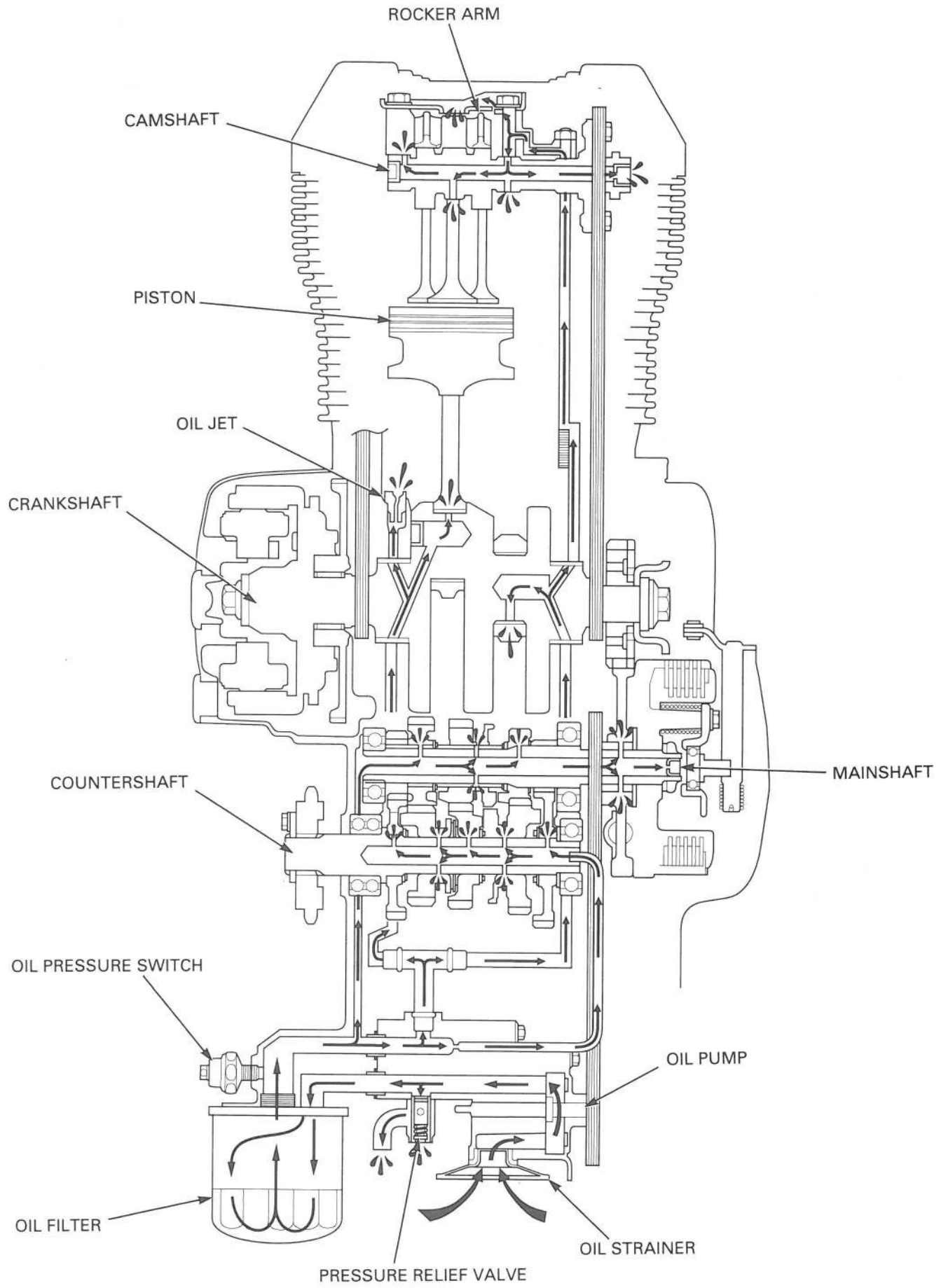

4. LUBRICATION SYSTEM

SERVICE INFORMATION	4-1	OIL PRESSURE CHECK	4-3
TROUBLESHOOTING	4-2	OIL PUMP	4-4

SERVICE INFORMATION

GENERAL

⚠ WARNING

- *If the engine must be running to do some work, make sure the area is well ventilated. Never run the engine in an enclosed area. The exhaust contains poisonous carbon monoxide gas that can cause loss of consciousness and may lead to death. Run the engine in an open area or with an exhaust evacuation system in an enclosed area.*
- *Used engine oil may cause skin cancer if repeatedly left in contact with the skin for prolonged periods. Although this is unlikely unless you handle used oil on a daily basis, it is still advisable to thoroughly wash your hands with soap and water as soon as possible after handling used oil. KEEP OUT OF REACH OF CHILDREN.*

- The engine must be removed from the frame before servicing the oil pump.
- When removing and installing the oil pump use care not to allow dust or dirt to enter the engine.
- If any portion of the oil pump is worn beyond the specified service limits, replace the oil pump as an assembly.
- After the engine has been installed, check that there are no oil leaks and that oil pressure is correct.
- For oil pressure indicator inspection, refer to section 19 of this manual.

SPECIFICATIONS

Unit: mm (in)

ITEM		STANDARD	SERVICE LIMIT
Engine oil capacity	at draining	2.2 liter (2.32 US qt, 1.94 Imp qt)	—
	at disassembly	2.9 liter (3.06 US qt, 2.55 Imp qt)	—
	at oil filter change	2.4 liter (2.54 US qt, 2.11 Imp qt)	—
Recommended engine oil		HONDA GN4 4-stroke oil or equivalent motor oil API service classification SF or SG Viscosity: SAE 10W-40	—
Oil pressure at oil pressure switch		530 kPa (5.4 kgf/cm ² , 77 psi) at 5,500 rpm (80°C/176°F)	—
Oil pump rotor	Tip clearance	0.15 (0.006)	0.20 (0.008)
	Body clearance	0.15 – 0.22 (0.006 – 0.009)	0.35 (0.014)
	Side clearance	0.02 – 0.07 (0.001 – 0.003)	0.10 (0.004)

LUBRICATION SYSTEM

TORQUE VALUES

Oil pump cover bolt	13 N•m (1.3 kgf•m, 9 lbf•ft)	
Oil pump driven sprocket bolt	15 N•m (1.5 kgf•m, 11 lbf•ft)	Apply a locking agent to the threads
Oil filter cartridge	10 N•m (1.0 kgf•m, 7 lbf•ft)	Apply oil to the threads and O-ring
Oil drain bolt	34 N•m (3.5 kgf•m, 25 lbf•ft)	
Oil pressure switch	12 N•m (1.2 kgf•m, 9 lbf•ft)	Apply sealant to the threads
Oil pressure switch wire terminal screw	2 N•m (0.2 kgf•m, 1.4 lbf•ft)	

TOOLS

Oil filter wrench	07HAA-PJ70100	
Oil pressure gauge	07506-3000000	or equivalent commercially available in U.S.A.
Oil pressure gauge attachment	07510-4220100	or equivalent commercially available in U.S.A.

TROUBLESHOOTING

Oil level low

- Oil consumption
- External oil leak
- Worn piston ring or incorrect piston ring installation
- Worn valve guide or seal

Oil contamination (White appearance)

- From coolant mixing with oil
 - Faulty water pump mechanical seal
 - Faulty head gasket
 - Water leak in crankcase

No oil pressure

- Oil level too low
- Oil pump drive chain or drive sprocket broken
- Oil pump damaged (pump shaft)
- Internal oil leak

Low oil pressure

- Pressure relief valve stuck open
- Clogged oil filter and strainer screen
- Oil pump worn or damaged
- Internal oil leak
- Incorrect oil being used
- Oil level too low

High oil pressure

- Pressure relief valve stuck closed
- Plugged oil filter, gallery, or metering orifice
- Incorrect oil being used

Seized engine

- No or low oil pressure
- Clogged oil orifice/passage
- Internal oil leak
- Non-recommended oil used

Oil contamination

- Deteriorated oil
- Faulty oil filter
- Worn piston ring (White appearance with water or moisture)
 - Damaged water pump mechanical seal
 - Damaged head gasket
 - Oil relief not frequent enough

Oil pressure warning indicator does not work

- Faulty oil pressure switch
- Short circuit in the indicator wire
- Low or no oil pressure
- Blown bulb

OIL PRESSURE CHECK

NOTE:

If the engine is cold, the pressure reading will be abnormally high. Warm up the engine to normal operating temperature before starting this test.

Warm up the engine.
Stop the engine.
Remove the left rear cover (page 7-3).

Remove the screw cover and screw.
Disconnect the oil pressure switch wire.

Remove the oil pressure switch.
Connect the oil pressure gauge attachment and gauge to the pressure switch hole.

TOOLS:

Oil pressure gauge

07506-300000
or equivalent
commercially
available in U.S.A.

Oil pressure gauge attachment 07510-4220100
or equivalent
commercially
available in U.S.A.

Check the oil level and add the recommended oil if necessary (page 3-11).

Start the engine and check the oil pressure at 5,500 rpm.

OIL PRESSURE: 530 kPa (5.4 kgf/cm², 77 psi) at 5,500 rpm (80 °C/176 °F)

Stop the engine and remove the oil pressure gauge attachment and gauge from the pressure switch hole.

Apply sealant to the oil pressure switch threads as shown and tighten it to the specified torque.

TORQUE: 12 N·m (1.2 kgf·m, 9 lbf·ft)

Connect the oil pressure switch wire and tighten the screw to specified torque.

TORQUE: 2 N·m (0.2 kgf·m, 1.4 lbf·ft)

NOTE:

Route the oil pressure switch wire correctly (page 1-27).

Start the engine.
Check that the oil pressure indicator goes out after one or two seconds. If the oil pressure indicator stays on, stop the engine immediately and determine the cause (page 19-14).

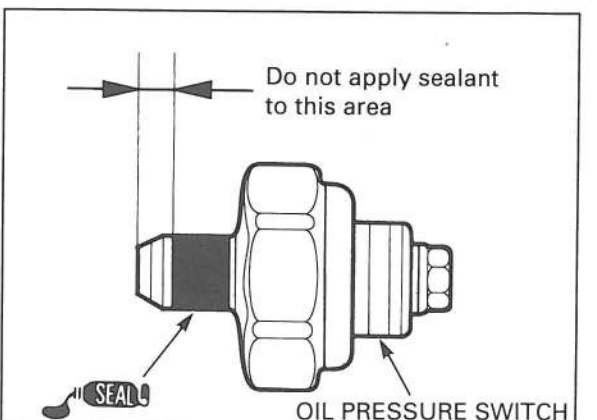
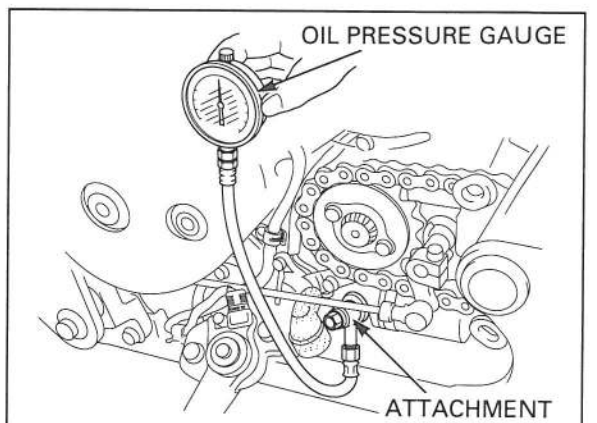
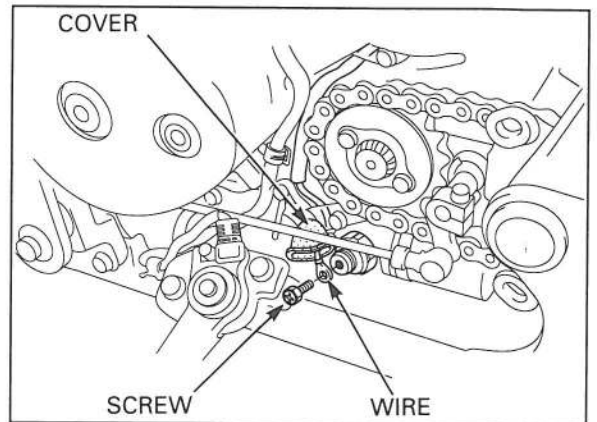
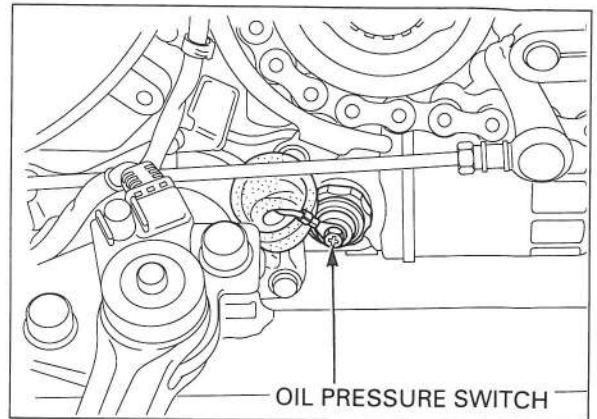

LUBRICATION SYSTEM

OIL PUMP

REMOVAL

When removing and installing the oil pump, use care not to allow dust or dirt to enter the engine.

Separate the crankcase (page 12-4).

Remove the bolt and oil relief pipe.

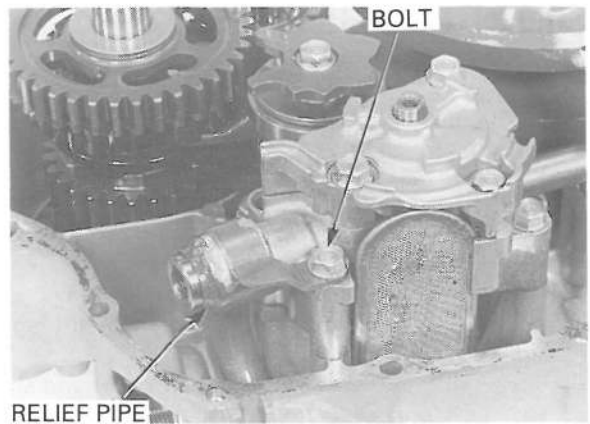

Remove the oil relief valve and O-ring.

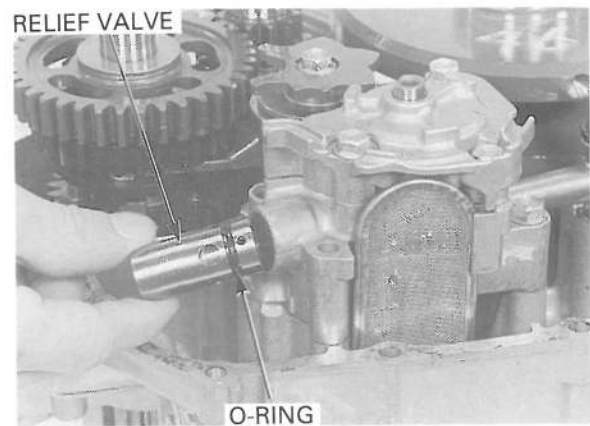

Remove the oil pump mounting bolts.

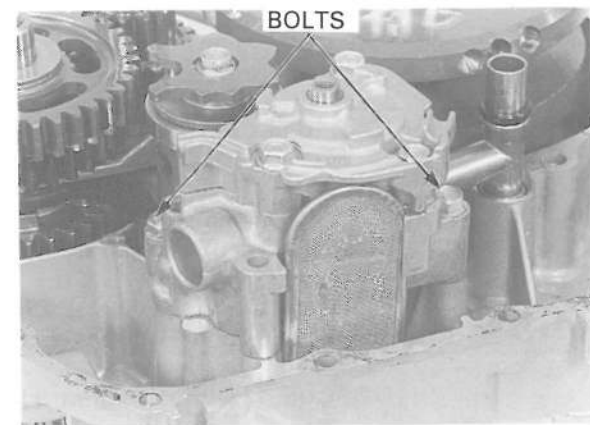

Remove the oil pump.
Remove the collars and O-rings.
Remove the dowel pin.

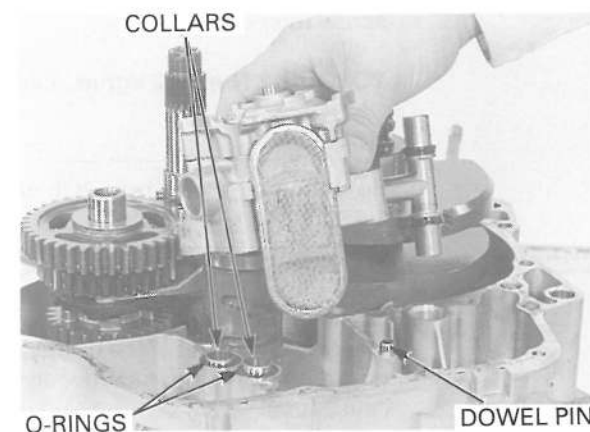

DISASSEMBLY

OIL PUMP DISASSEMBLY

NOTE:

If any portion of the oil pump is worn beyond the specified service limits, replace the oil pump as an assembly.

Remove the oil pipe, oil pipe seal and O-rings.

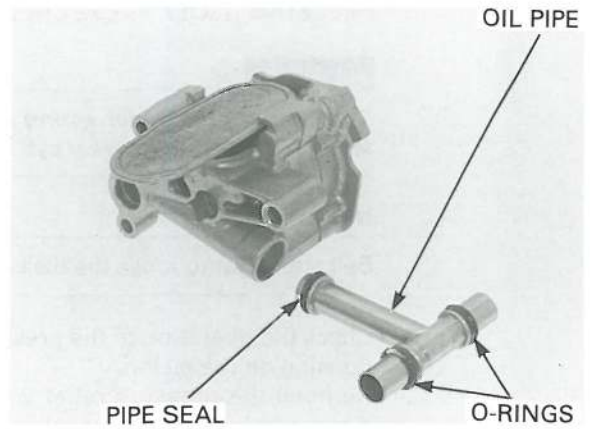

Remove the oil strainer and O-ring.

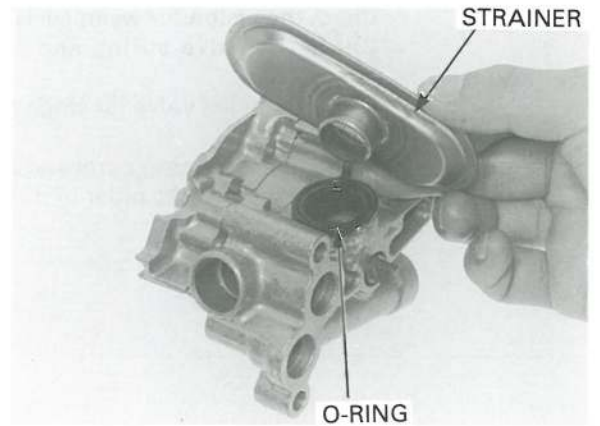

Remove the bolts and pump cover from pump body.

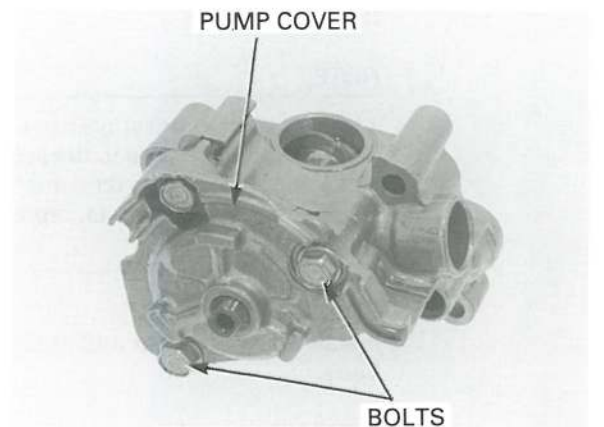

Remove the dowel pins.
Remove the washer, drive shaft, drive pin, inner rotor and outer rotor.

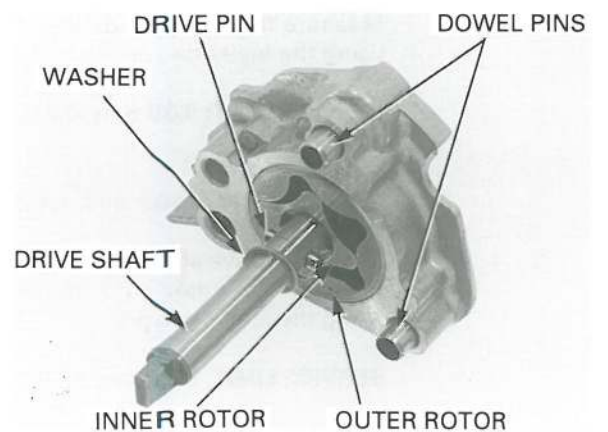

PRESSURE RELIEF VALVE CHECK

⚠ WARNING

The snap ring is under spring pressure. Use care when removing it and wear eye and face protection.

NOTE:

Be careful not to loose the disassembled parts.

Check the operation of the pressure relief valve by pushing on the piston.
Remove the pressure relief valve snap ring and disassemble the pressure relief valve.

Check the piston for wear, sticking or damage.
Check the valve spring and piston for wear or damage.
Check the relief valve for clogging for damage.

Clean the remaining parts and assemble the relief valve in the reverse order of disassembly.

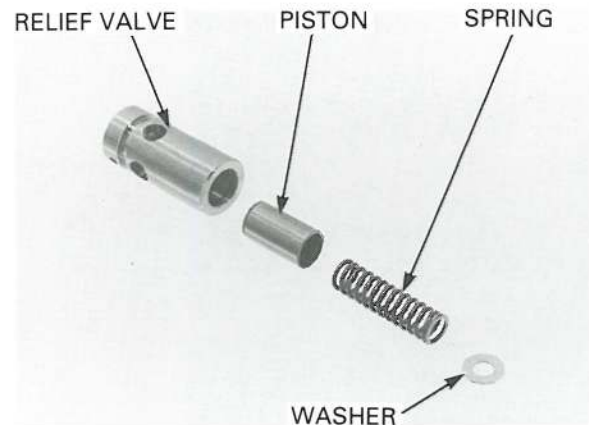
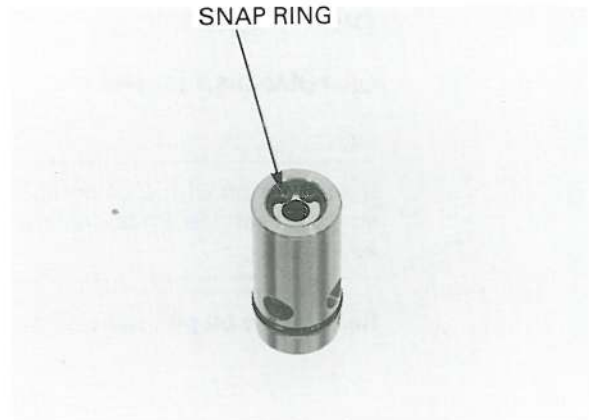

INSPECTION

NOTE:

- Measure at several places and use the largest reading to compare to the service limit.
- If any portion of the oil pump is worn beyond the specified service limits, replace the oil pump as an assembly.

BODY CLEARANCE

Install the inner rotor and outer rotor to the pump body.

Install the drive shaft properly.

Measure the pump body-to-outer rotor clearance using the feeler gauge.

SERVICE LIMIT: 0.35 mm (0.014 in)

TIP CLEARANCE

Install the inner rotor and outer rotor to the pump body.

Install the drive shaft properly.

Measure the outer rotor-to-inner rotor clearance using the feeler gauge.

SERVICE LIMIT: 0.20 mm (0.008 in)

BODY CLEARANCE

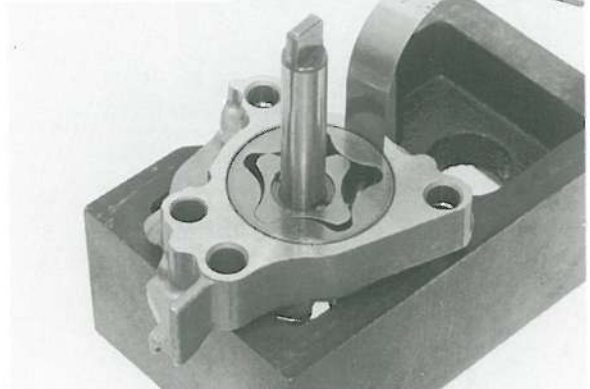

TIP CLEARANCE



SIDE CLEARANCE

Install the inner rotor and outer rotor to the pump body.
 Measure the rotor side-to-pump body clearance using the feeler gauge and straight edge.

SERVICE LIMIT: 0.10 mm (0.004 in)

SIDE CLEARANCE

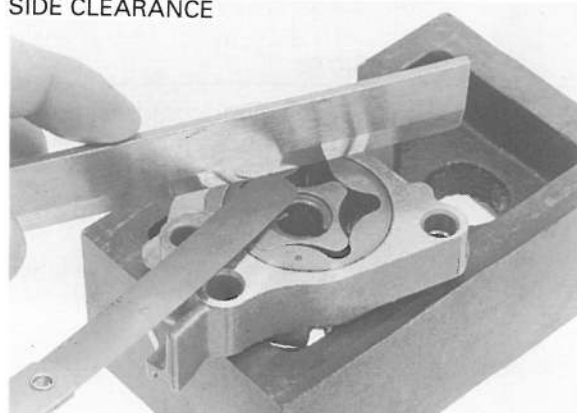

ASSEMBLY

NOTE:

Before assembly, clean all disassembled parts thoroughly with clean engine oil.

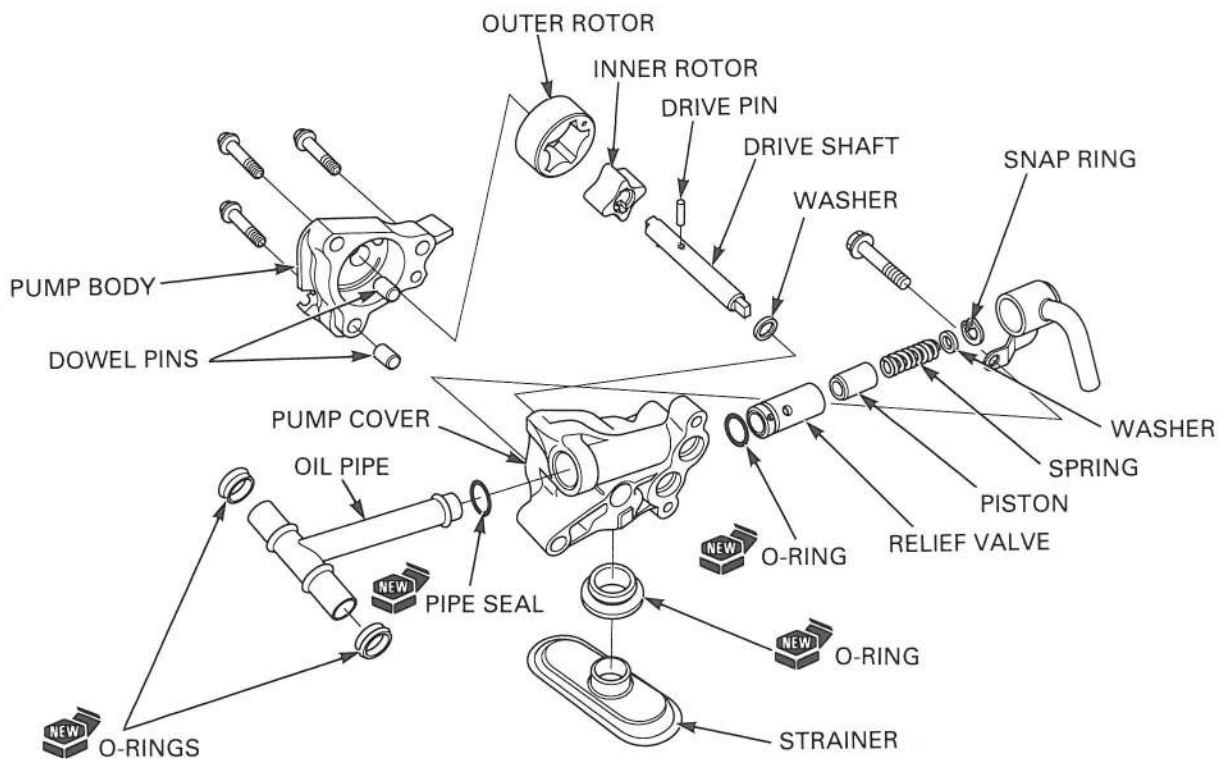

Install the outer rotor to the pump body.

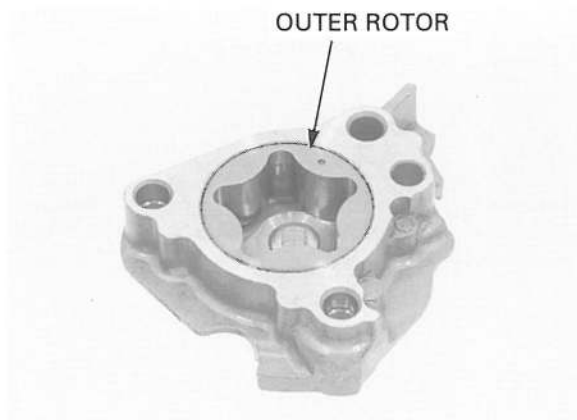

LUBRICATION SYSTEM

Install the inner rotor to the outer rotor.

NOTE:

When inner rotor installing, install it with the slots side facing the pump cover.

Install the drive shaft and drive pin by aligning the slots in the inner rotor.
Place the washer into the inner rotor groove.
Install the dowel pin to the pump cover.

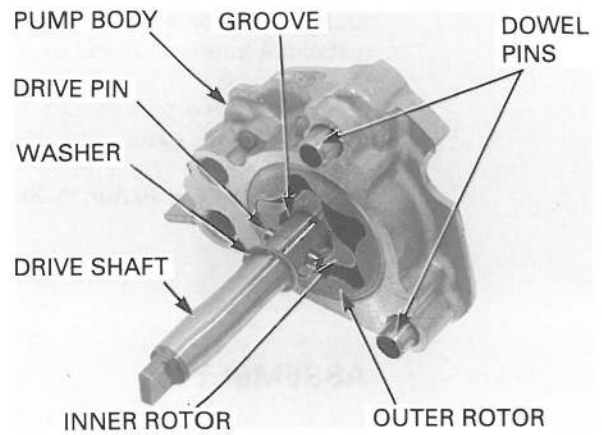

Install the pump body to the pump cover.
Install and tighten the bolts to the specified torque.

TORQUE: 13 N·m (1.3 kgf·m, 9 lbf·ft)

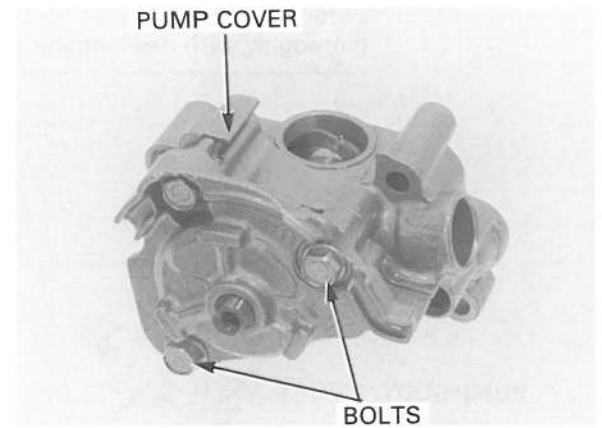

Clean the oil strainer.
Apply oil to the new O-ring and install the oil strainer.
Install the oil strainer to the oil pump aligning it to the groove on the oil pump.

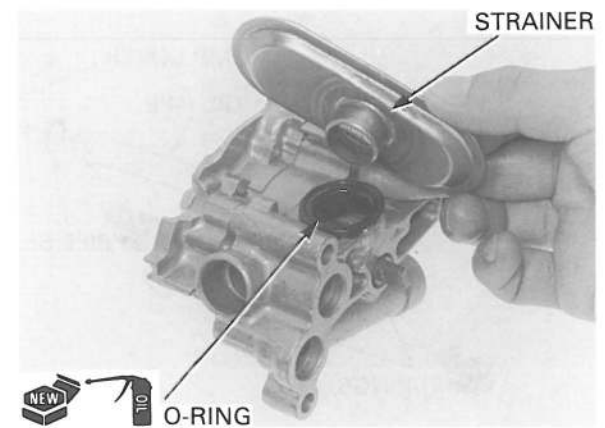

Install the oil strainer to the pump body groove securely.

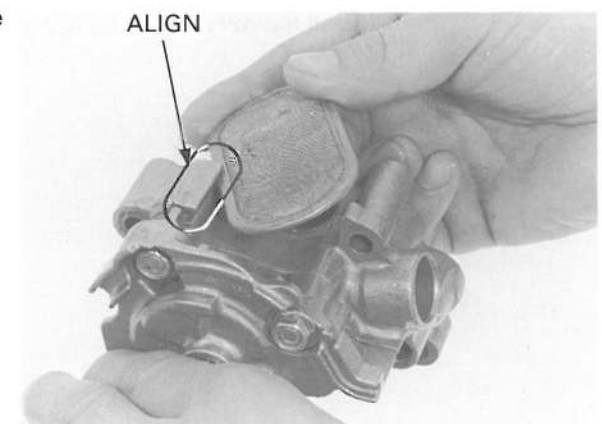

Apply oil to the new oil pipe seal and new O-rings, then install to the oil pipe.

NOTE:

Install the O-rings with their tapered side facing out.

Install the oil pipe to the oil pump securely.

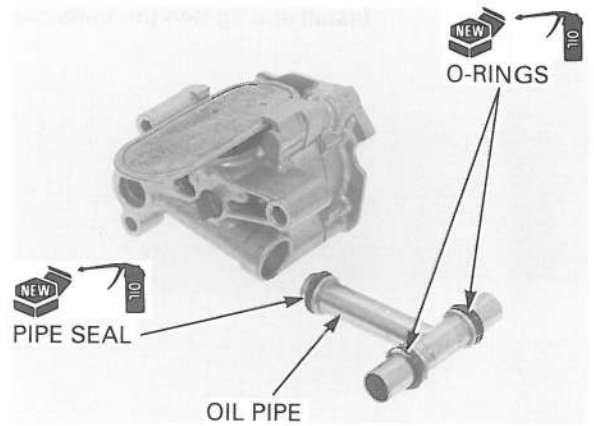

INSTALLATION

Install the dowel pin.
Install the collars.
Apply oil to the new O-rings and install onto the collars.

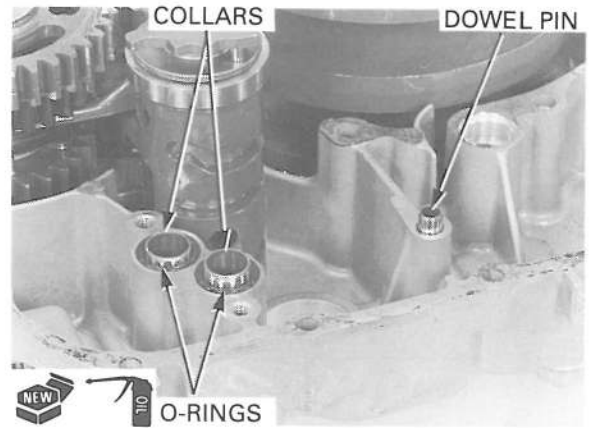

Install the oil pump into the crankcase securely.

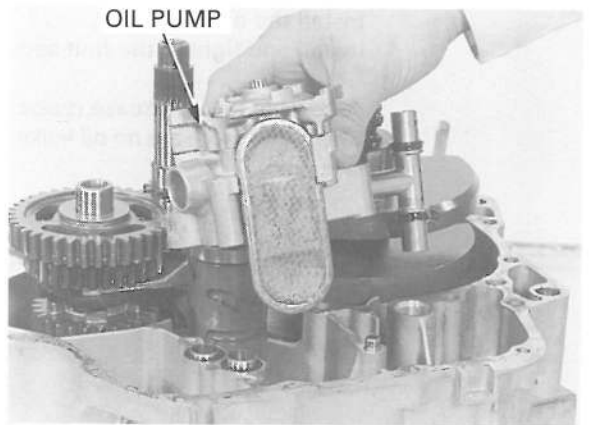

Be careful not to damage the O-rings at oil pump installation.

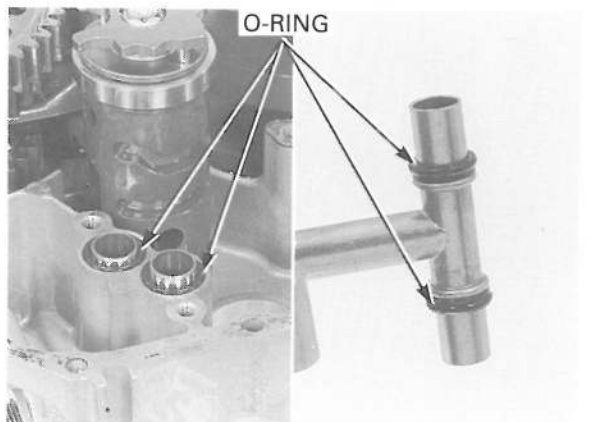

VT750CD/CD2 (After 2000) :
VT750C3/CD3 :

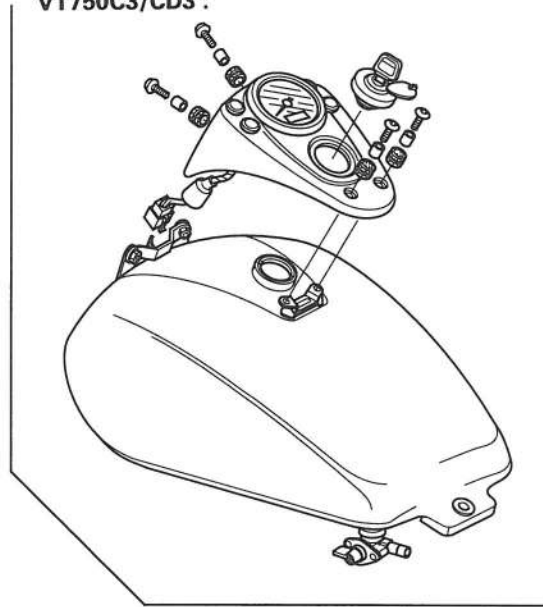

VT750C :
VT750CD/CD2 ('98 - 2000) :

19 N•m (1.9 kgf•m, 14 lbf•ft)

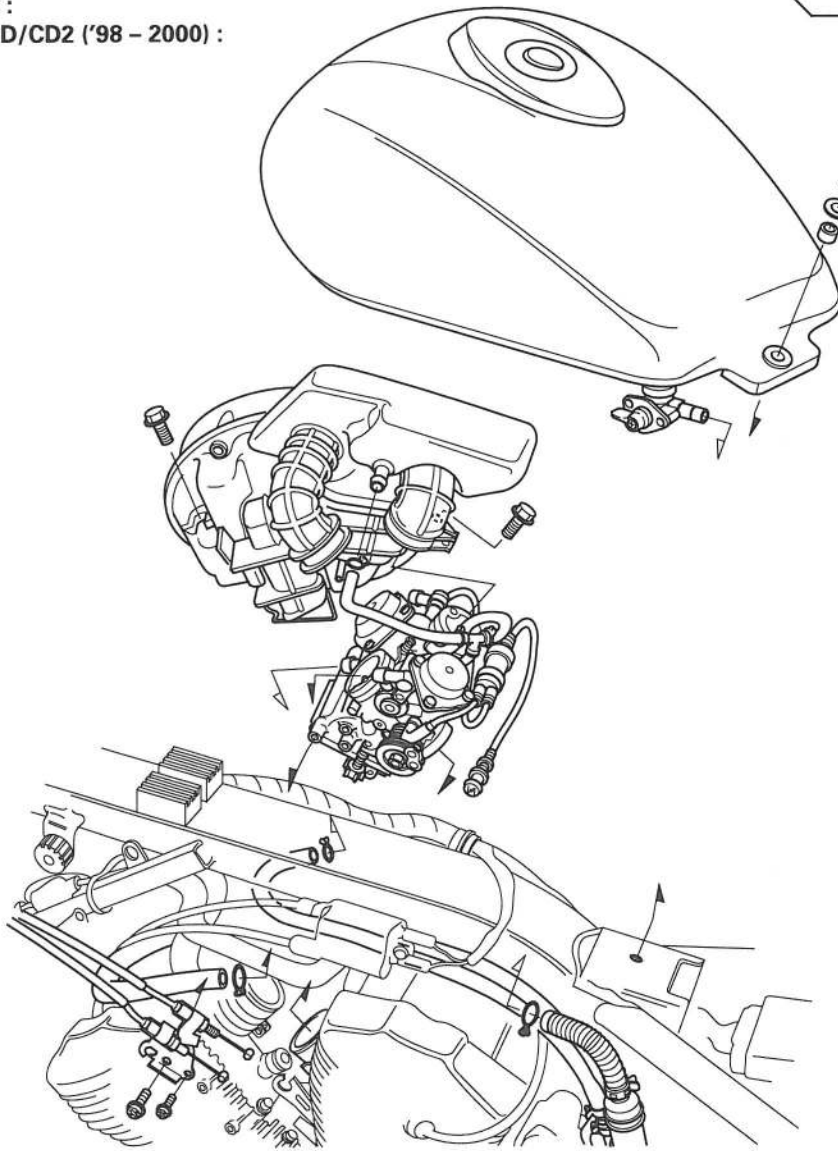

5. FUEL SYSTEM

SERVICE INFORMATION	5-1	CARBURETOR REASSEMBLY	5-19
TROUBLESHOOTING	5-3	CARBURETOR INSTALLATION	5-21
AIR CLEANER HOUSING	5-4	PILOT SCREW ADJUSTMENT	5-22
SUB-AIR CLEANER ELEMENT	5-5	FUEL PUMP	5-24
AIR CLEANER CHAMBER	5-6	FUEL FILTER	5-27
CARBURETOR REMOVAL	5-8	HIGH ALTITUDE ADJUSTMENT (U.S.A. ONLY)	5-27
CARBURETOR DISASSEMBLY/ ASSEMBLY	5-10	EVAPORATIVE EMISSION PURGE CONTROL VALVE INSPECTION (CALIFORNIA TYPE ONLY)	5-28
VACUUM CHAMBER	5-11		
FLOAT CHAMBER	5-13	EVAPORATIVE EMISSION CARBURETOR AIR VENT CONTROL VALVE INSPECTION (CALIFORNIA TYPE ONLY)	5-30
AIR CUT-OFF VALVE	5-17		
CARBURETOR BODY CLEANING	5-17		
CARBURETOR SEPARATION	5-18		

SERVICE INFORMATION

GENERAL

▲ WARNING

- Gasoline is extremely flammable and is explosive under certain condition. **KEEP OUT OF REACH OF CHILDREN.**
- If the engine must be running to do some work, make sure the area is well-ventilated. Never run the engine in an enclosed area. The exhaust contains poisonous carbon monoxide gas that may cause loss of the consciousness and may lead to death. Run the engine in an open area or with an exhaust evacuation system in an enclosed area.
- Bending or twisting the control cables will impair smooth operation and could cause the cable to stick or bind, resulting in loss of vehicle control.

- Work in a well ventilated area. Smoking or allowing flames or sparks in the work area or where gasoline is stored can cause a fire or explosion.

CAUTION:

Be sure to remove the diaphragms before cleaning air and fuel passages with compressed air. The diaphragms might be damaged.

- For fuel tank removal and installation, refer to Section 2.
- Before disassembling the carburetor, place an approved gasoline container under the carburetor drain tube, loosen the carburetor drain screw and drain the carburetor.
- When disassembling the fuel system parts, note: the locations of the O-rings. Replace them with new ones on reassembly.
- After removing the carburetor, wrap the intake ports of the engine with a shop towel or cover them with a piece of tape to prevent any foreign material from dropping into the engine. Be sure to remove the cover when reinstalling the carburetor.

NOTE:

If the vehicle is to be stored for more than one month, drain the float bowls. Fuel left in the float bowls may cause clogged jets resulting in hard starting or poor driveability.

FUEL SYSTEM

SPECIFICATIONS

ITEM			SPECIFICATIONS
Carburetor identification number	49 state type	'98	VDFFG
		After '98	VDFFJ
	California type	'98	VDFEB
		After '98	VDFEC
	Canada type	'98 VT750C/CD/CD2	VDFFG
'98 VT750C3/CD3 After '98		VDFFJ	
Main jet	Front	#105	
	Rear	#110	
Slow jet		#40	
Pilot screw	Initial/final opening	See page 5-22	
Float level		7.0 mm (0.28 in)	
Base carburetor (for synchronization)		Rear cylinder (#1)	
Idle speed		1,000 ± 100 rpm	
Carburetor vacuum difference		27 kPa (20 mm Hg, 0.7 in Hg)	
PAIR control valve specified vacuum		325 mm Hg (12.8 in Hg)	
Throttle grip free play		2 – 6 mm (1/12 – 1/4 in)	
Fuel pump flow capacity		Minimum 900cm ³ (30.4 US oz, 31.7 Imp oz) per minute at 12V	

TORQUE VALUES

Air cleaner housing cover bolt	2 N•m (0.2 kgf•m, 1.4 lbf•ft)
Fuel tank bolt	19 N•m (1.9 kgf•m, 14 lbf•ft)
Fuel valve nut	34 N•m (3.5 kgf•m, 25 lbf•ft)

TOOLS

Carburetor float level gauge	07401-0010000
------------------------------	---------------

TROUBLESHOOTING

Oil level low

- No fuel in tank
- No fuel to carburetor
 - Fuel strainer clogged
 - Fuel filter clogged
 - Fuel valve stuck
 - Fuel line clogged
 - Fuel tank breather clogged
 - Float level faulty
 - Fuel pump malfunction
- Too much fuel getting to the engine
 - Air cleaner clogged
 - Flooded carburetor
- Intake air leak
- Fuel contaminated/deteriorated
 - Jet clogged
- Improper starting enrichment valve operation
- Slow circuit or starting enrichment valve circuit clogged
- Improper throttle operation
- No spark at plug (ignition system faulty)

Lean mixture

- Fuel jets clogged
- Float valve faulty
- Float level too low
- Fuel line restricted
- Intake air leak
- Throttle valve faulty
- Vacuum piston faulty
- Throttle valve faulty
- Fuel pump malfunction

Rich mixture

- Starting enrichment valve open
- Float valve faulty
- Float level too high
- Air jets clogged
- Air cleaner element contaminated
- Flooded carburetor

Engine stalls, hard to start, rough idling

- Fuel line restricted
- Ignition system malfunction
- Fuel mixture too lean/rich
- Fuel contaminated/deteriorated
 - Jet clogged
- Intake air leak
- Idle speed misadjusted
- Float level misadjusted
- Fuel tank breather clogged
- Pilot screw misadjusted
- Slow circuit or starting enrichment valve circuit clogged
- Carburetor synchronization misadjusted
- Fuel pump malfunction
- Valve clearance misadjusted
- Cylinder compression too low

Afterburn when engine braking is used

- Lean mixture in slow circuit
- Air cut-off valve malfunction

Backfiring or misfiring during acceleration

- Ignition system malfunction (Section 15)
- Fuel mixture too lean

Poor performance (driveability) and poor fuel economy

- Fuel system clogged
- Ignition system malfunction (Section 15)

AIR CLEANER HOUSING

REMOVAL

Remove the fuel tank (page 2-4).

Remove the air cleaner housing mounting bolts.

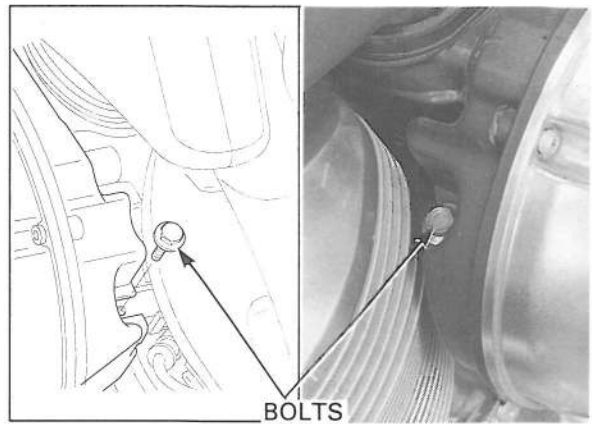

Loosen the air cleaner housing-to-air cleaner chamber band.
Remove the air cleaner housing.

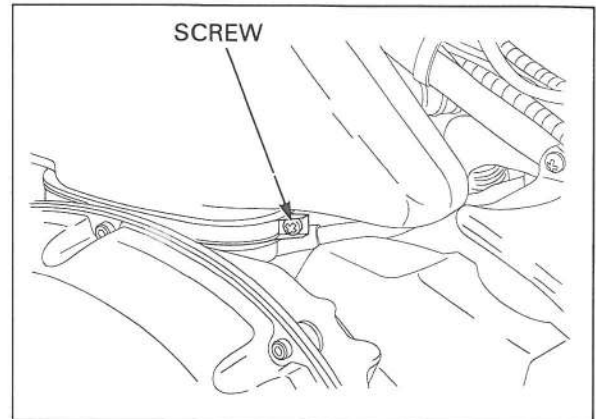

INSTALLATION

NOTE:

When installing the cleaner housing, apply grease to the inside of the air cleaner housing-to-air cleaner chamber band.

Install the air cleaner housing, aligning its boss into the grommet on the front cylinder head fin.

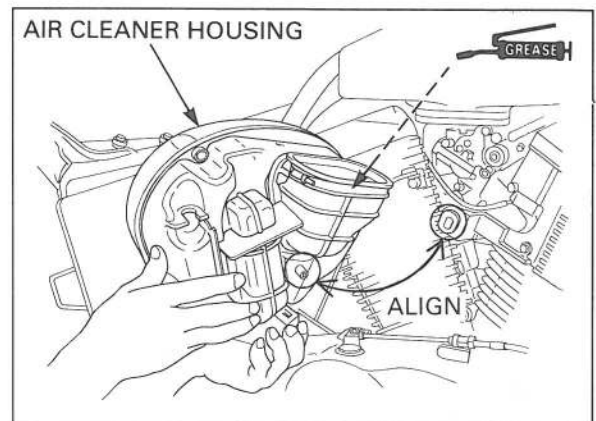

Tighten the air cleaner housing-to-air cleaner chamber band securely.

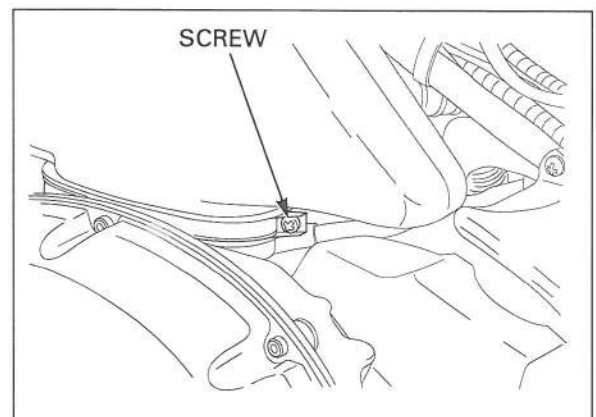

Install and tighten the air cleaner housing mounting bolts securely.

Install the fuel tank (page 2-4).

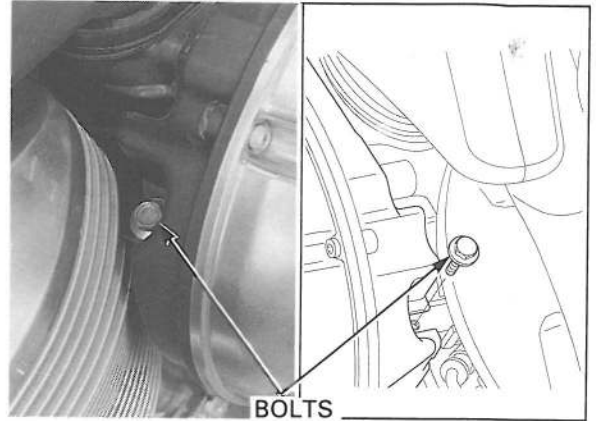

SUB-AIR CLEANER ELEMENT

Remove the fuel tank (page 2-4).

Remove the sub-air cleaner housing cover.

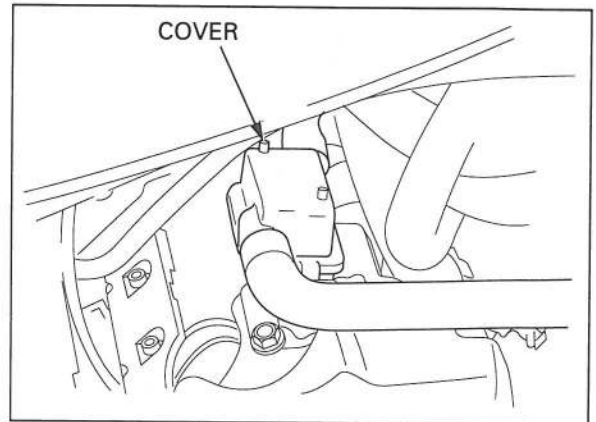

Remove the element.

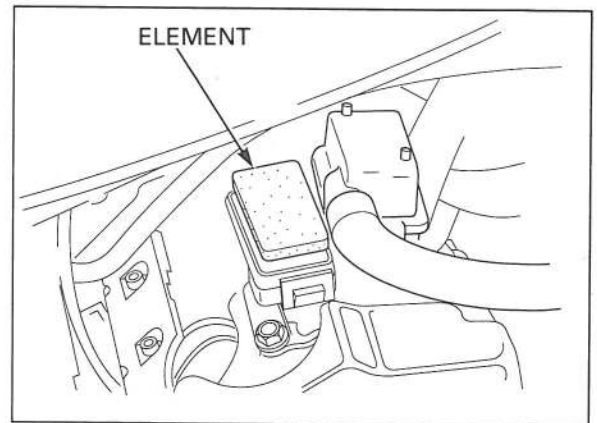

Wash the element in non-flammable or high flash point solvent, squeeze out the solvent thoroughly, and allow the element to dry.

⚠ WARNING

Never use gasoline or low flash point solvents for cleaning the element. A fire or explosion could result.

Allow the element to dry thoroughly. Soak the element in gear oil (SAE #80-90) and squeeze out the excess.

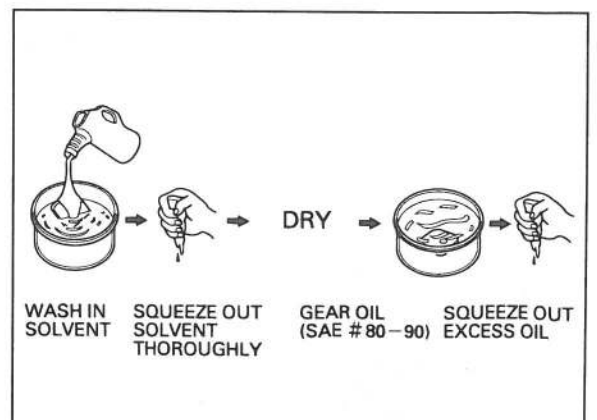

FUEL SYSTEM

Install the element and cover.
Install the fuel tank (page 2-4).

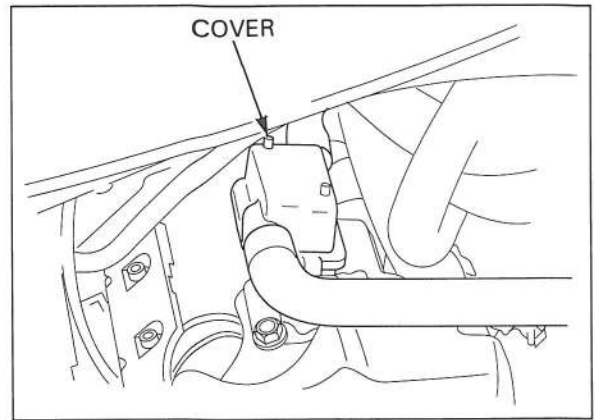

AIR CLEANER CHAMBER

REMOVAL

Remove the air cleaner housing (page 5-4).

Loosen the intake duct hose bands at the carburetors and pull out the air cleaner chamber.

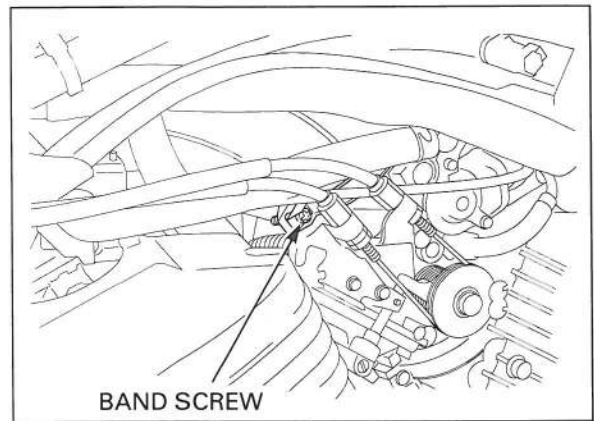
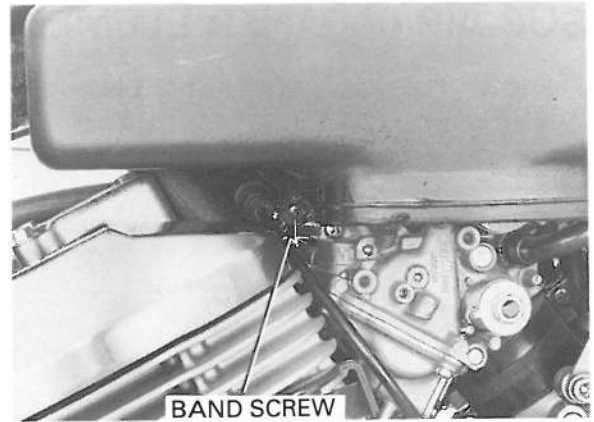

Disconnect the crankcase breather tube.
Remove the air cleaner chamber.

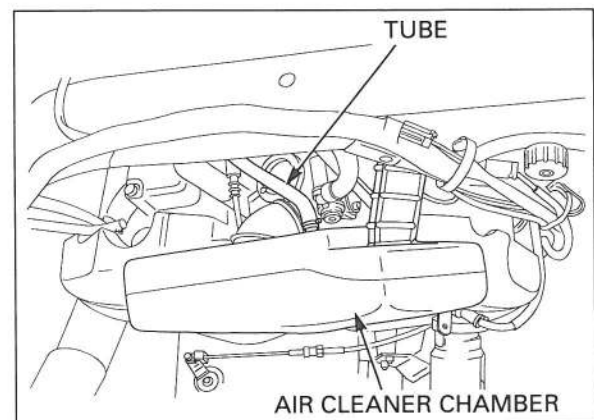

INSTALLATION

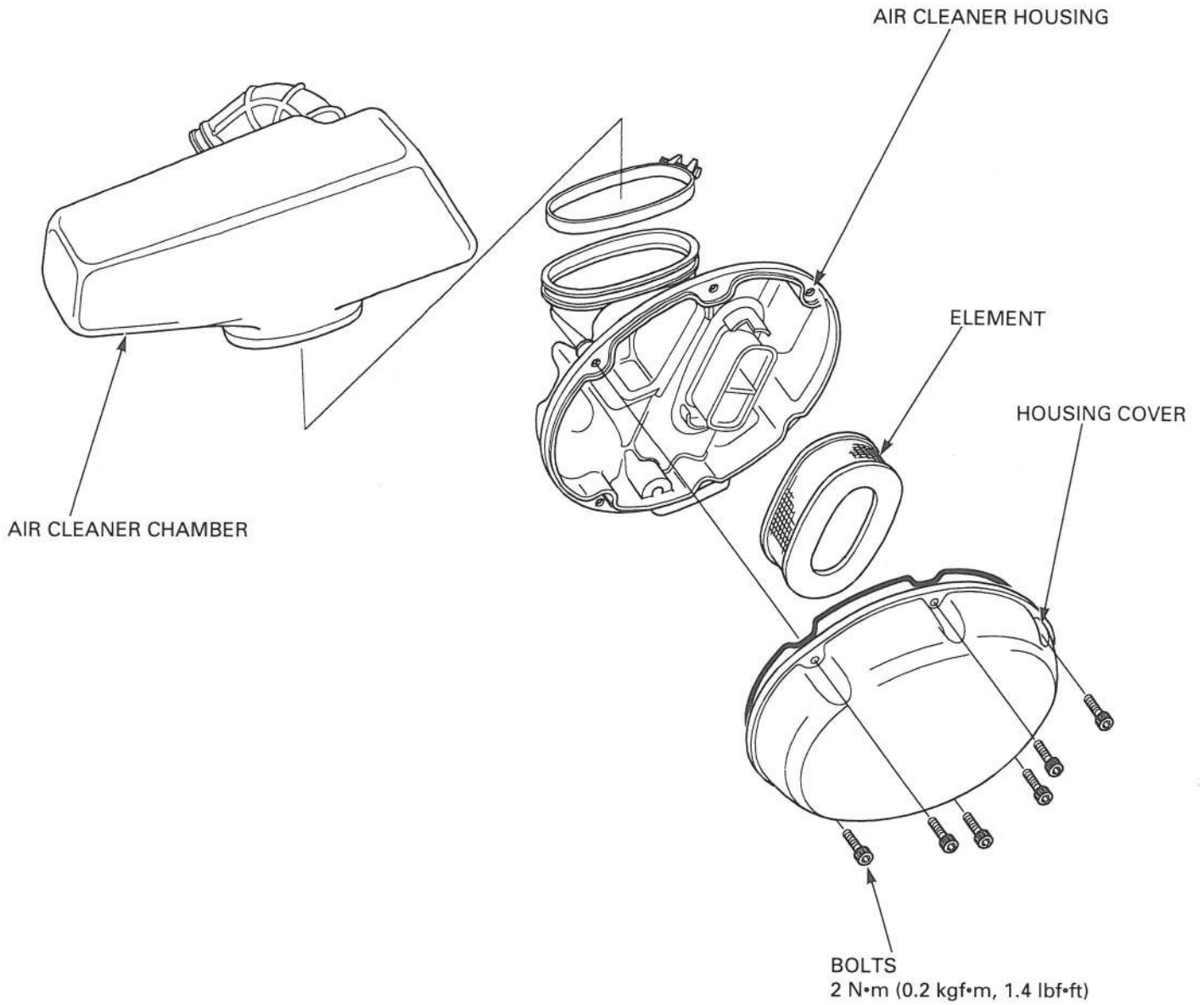

Connect the crankcase breather tube.

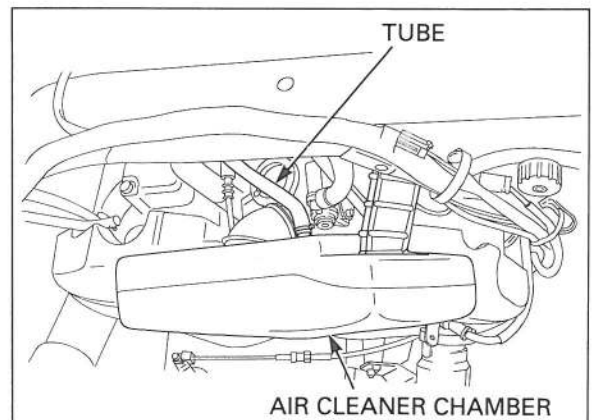

FUEL SYSTEM

Install the air cleaner chamber and connect the intake ducts to the carburetors and tighten the band screws.

Install the air cleaner housing (page 5-4).

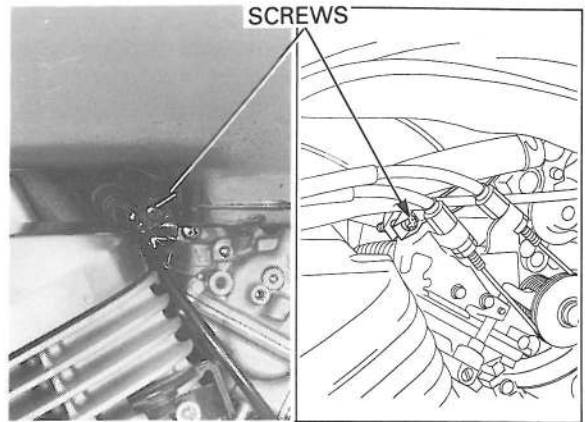

CARBURETOR REMOVAL

⚠ WARNING

Gasoline is extremely flammable and is explosive under certain conditions. KEEP OUT OF REACH OF CHILDREN.

Remove the air cleaner housing (page 5-4).
Remove the air cleaner chamber (page 5-6).
Remove the left side cover (page 2-4).

Loosen the carburetor drain screws and drain the carburetor.

Disconnect the fuel tube from the joint.

Remove the screws and throttle cable holder.
Remove the throttle cables from the throttle link.
Loosen the insulator band screw.
Disconnect the sub-air cleaner tube.

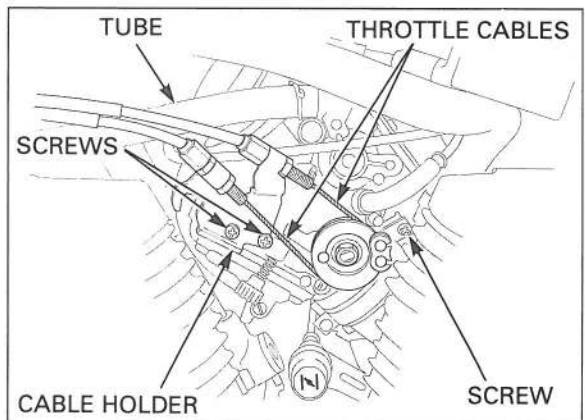
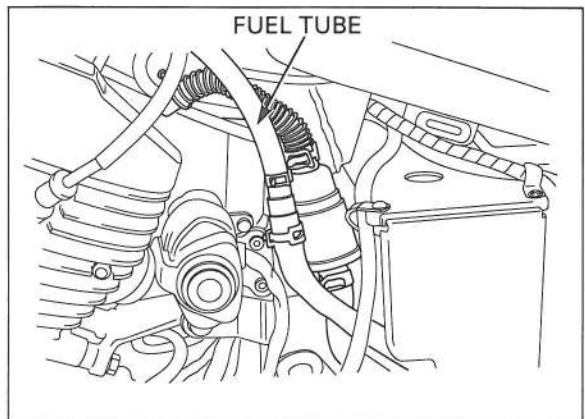

Remove the spark plug cap.
Remove the bolts then remove the rear cylinder left side fin and starting enrichment (SE) valve knob.

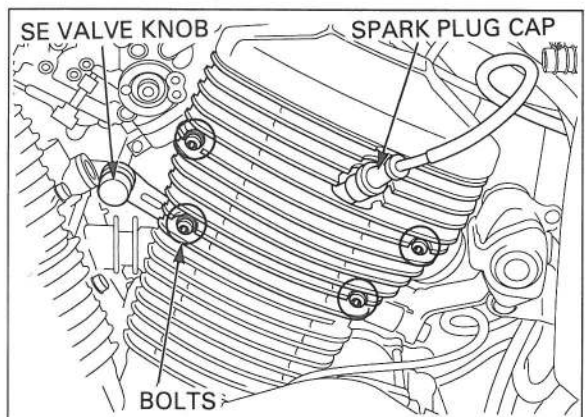

Disconnect the sub-air cleaner tubes from the front side carburetor.
Loosen the insulator band screw and remove the carburetors through the right side of the frame.

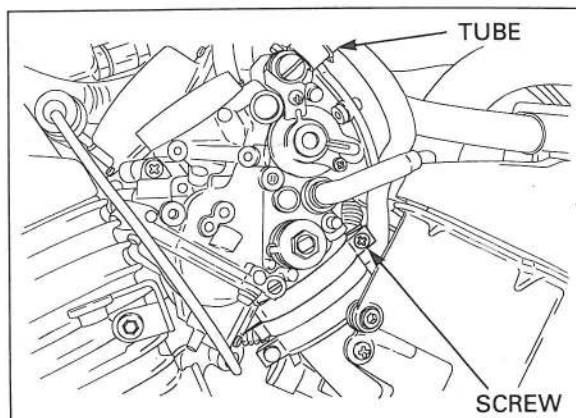

Remove the starting enrichment (SE) valve cable and SE valve from the carburetor by loosening each lock nut.
Remove the air tubes (carburetors-to-air cleaner) and fuel tube from the carburetor.

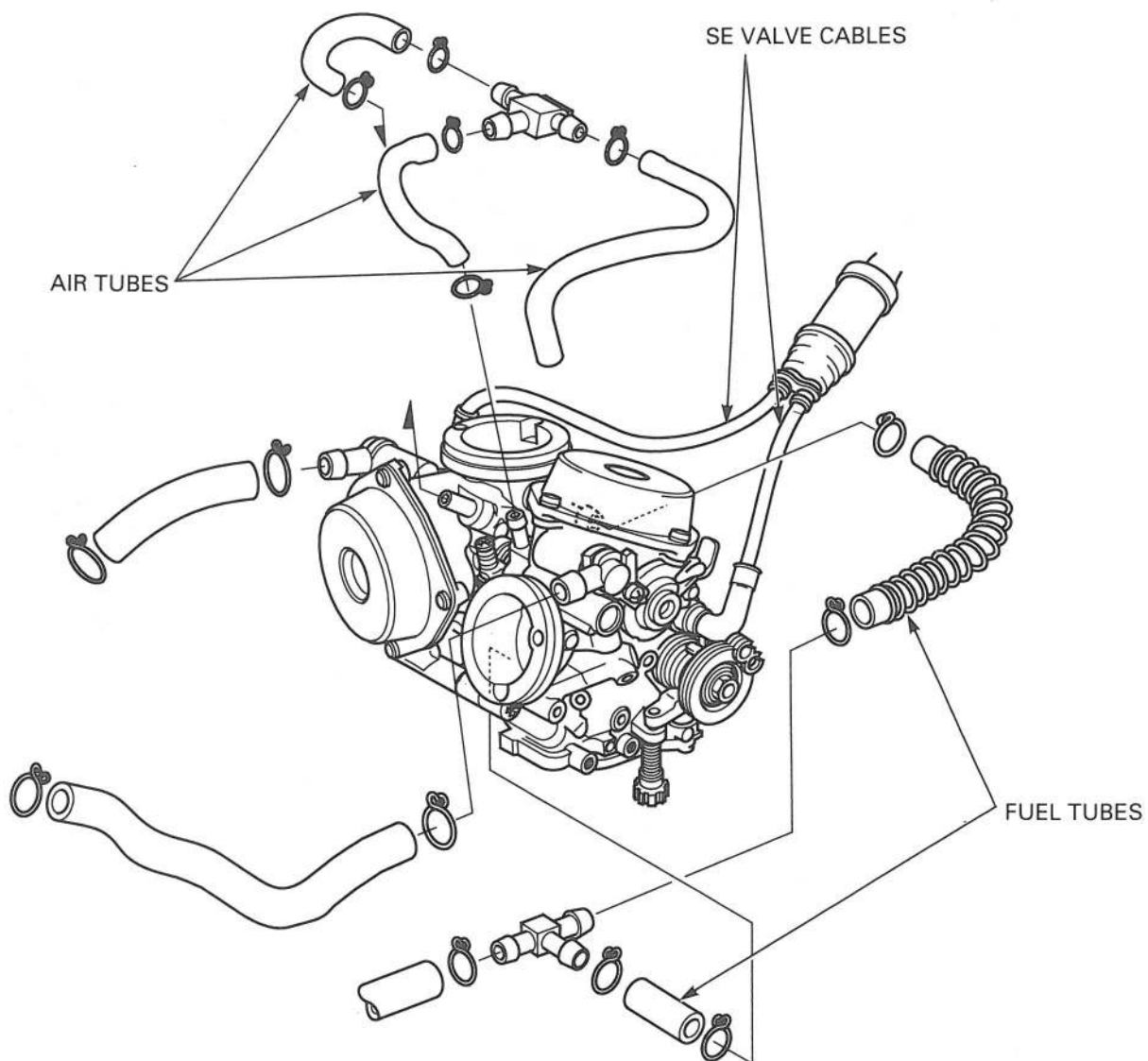

CARBURETOR DISASSEMBLY/ ASSEMBLY

NOTE:

- Vacuum chamber, float chamber and jets can be serviced without separating the carburetors.
- Note the location of each carburetor part so that they can be put back in the original location.
- Keep each carburetor's parts separate from the other's so you can install the parts in their original positions.
- For the following component inspections refer to the applicable pages.
 - Vacuum chamber (page 5-11)
 - Float chamber (page 5-13)
 - Pilot screw (page 5-14)
 - Jets (page 5-13)

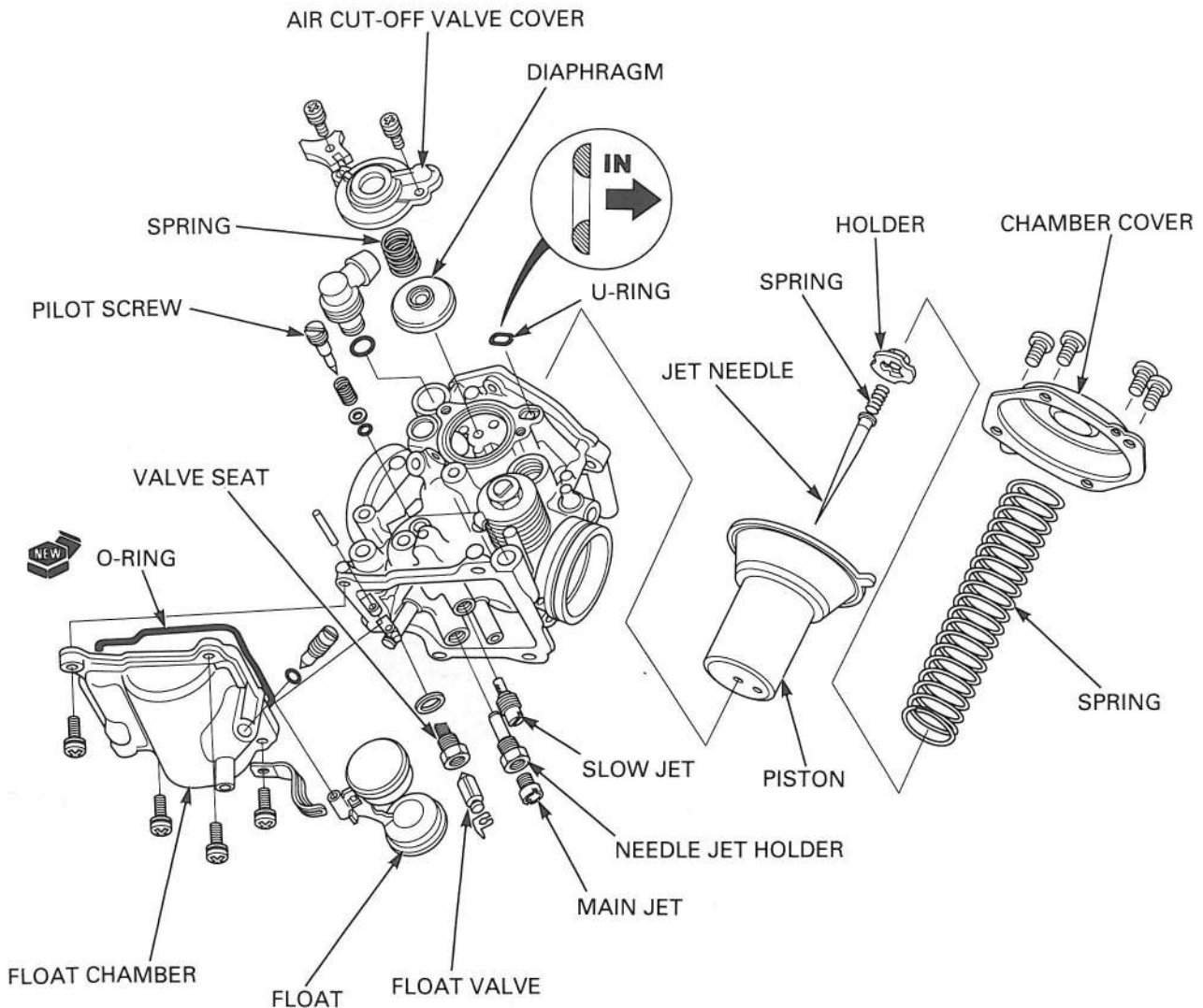

VACUUM CHAMBER

DISASSEMBLY

Remove the four screws and vacuum chamber cover.

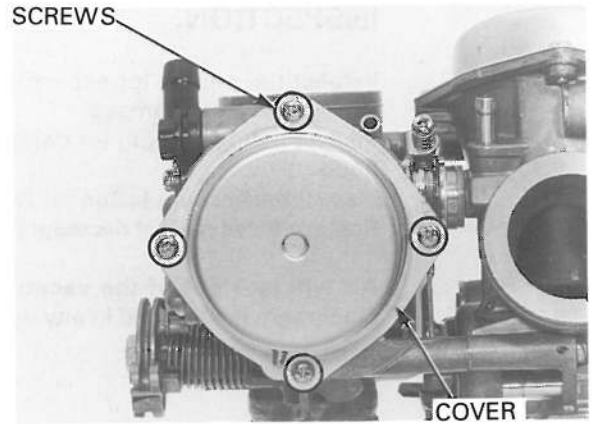

Remove the spring, and diaphragm/vacuum piston.

Inspect the vacuum piston for wear, nicks, scratches or other damage.

Make sure the piston moves up and down freely in the chamber.

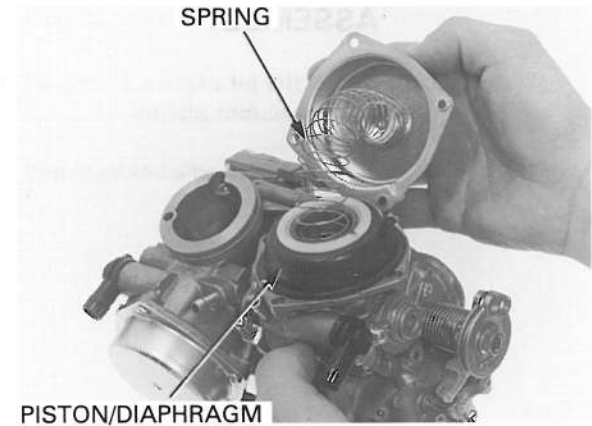

Push the jet needle holder in and turn it in 90 degrees counterclockwise.

CAUTION:

Be careful not to damage the diaphragm.

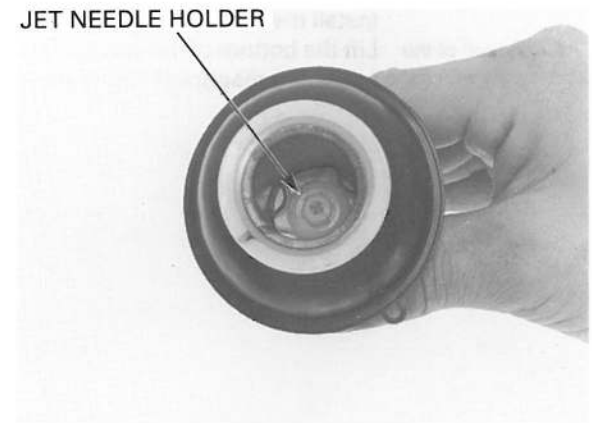

Remove the jet needle holder, spring and jet needle from the piston.

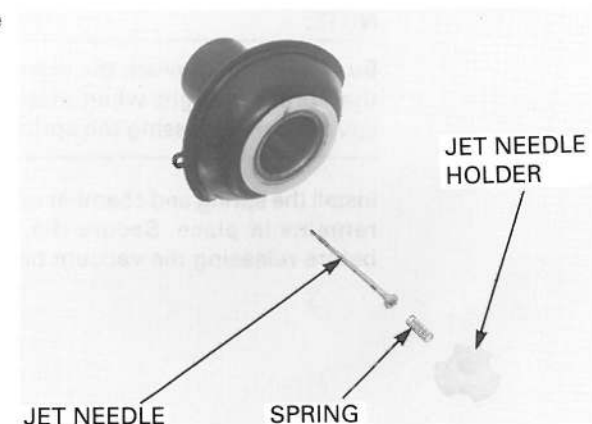

INSPECTION

Inspect the needle for excessive wear at the tip, bending or other damage.
Inspect the diaphragm for damage, fatigue or pin holes.
Inspect the vacuum piston for wear or damage.
Replace these parts if necessary.

Air will leak out of the vacuum chamber if the diaphragm is damaged in any way—even a pin hole.

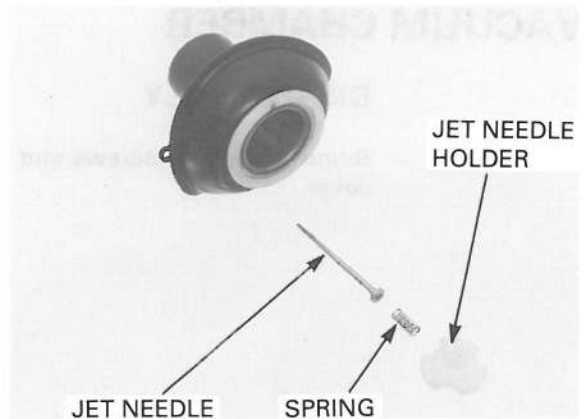

ASSEMBLY

Install the jet needle, spring and jet needle holder to the vacuum piston.

Push the jet needle holder in and turn it in 90 degrees clockwise.

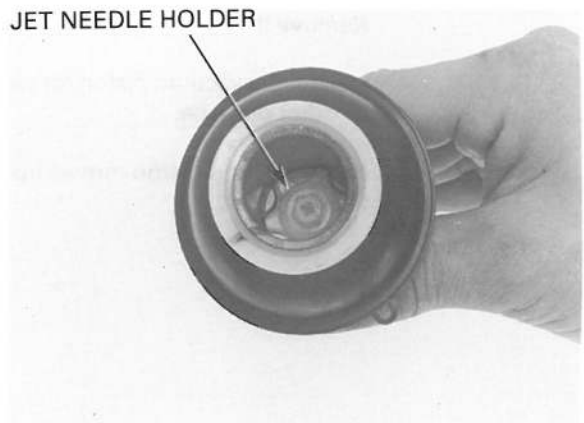

Align the tab of the diaphragm with the cavity.

Install the vacuum piston/diaphragm with the cavity. Lift the bottom of the vacuum piston with your finger to set the diaphragm lip in the carburetor body.

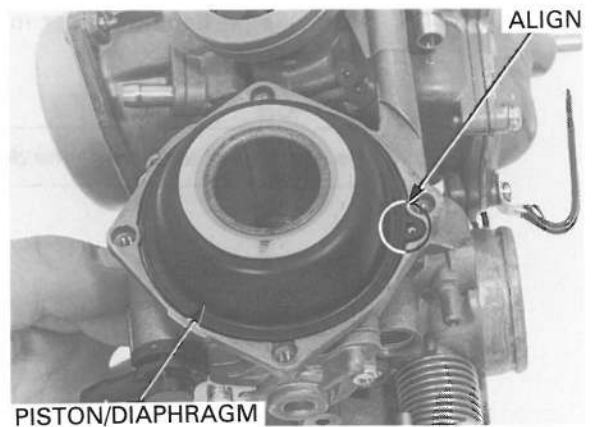

NOTE:

Be careful not to pinch the diaphragm, and to keep the spring straight when installing the chamber cover by compressing the spring.

Install the spring and chamber cover while the piston remains in place. Secure the cover with screws before releasing the vacuum piston.

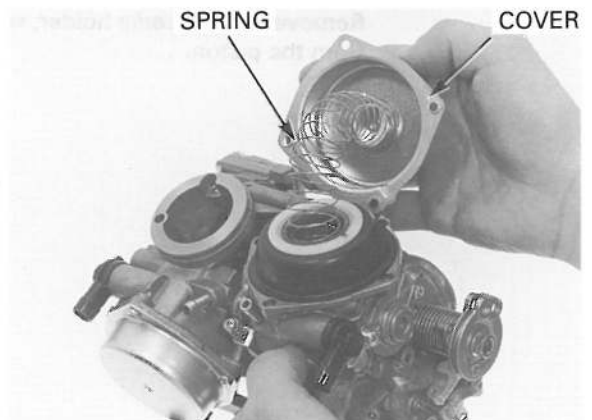

Install and tighten the screws securely.

SCREWS

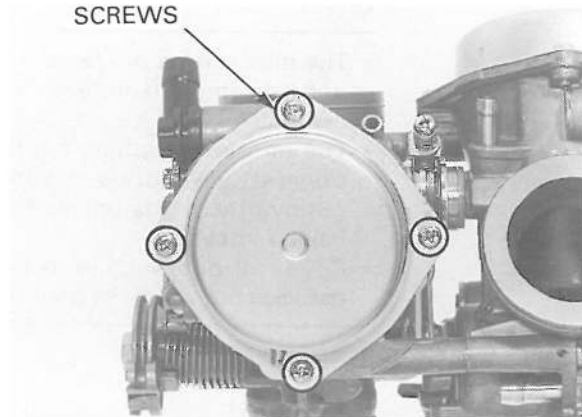

FLOAT CHAMBER

DISASSEMBLY

Remove the screws, float chamber and O-ring.

SCREWS

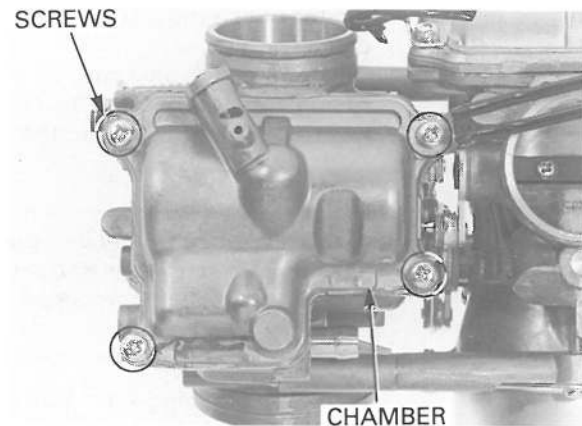

Remove the float pin, float and float valve.

FLOAT VALVE

FLOAT PIN

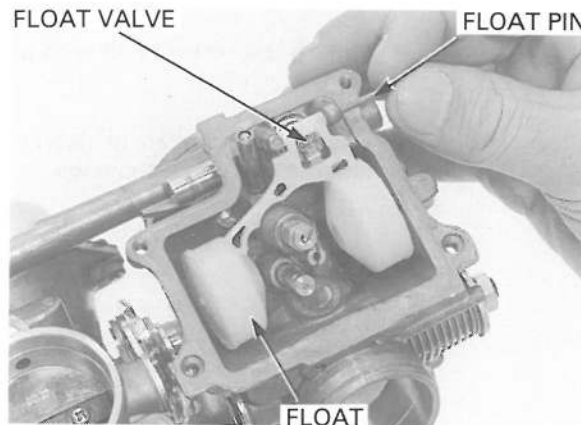

CAUTION:

Handle all jets with care. They can easily be scored or scratched.

Remove the main jet, needle jet holder, slow jet and valve seat/filter.

MAIN JET

VALVE SEAT/FILTER

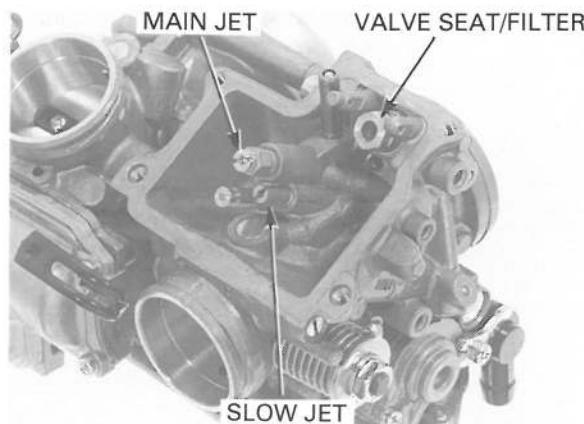

SLOW JET

FUEL SYSTEM

NOTE:

- The pilot screws are factory pre-set and should not be removed unless the carburetors are overhauled.
- The pilot screw plugs are factory installed to prevent pilot screw misadjustment. Do not remove the plugs unless the pilot screws are being removed.
- Cover all openings with tape to keep metal particles out when the plugs are drilled.

Center punch the pilot screw plug center the drill point.
Drill through the plug with a 4 mm (5/32 in) drill bit. Attach a drill stop to the bit 3 mm (1/8 in) from the end to prevent drilling into the pilot screw.

CAUTION:

- **Be careful not to drill into the pilot screw.**
- **Both pilot screws must be replaced even if only one requires it, for proper pilot screw adjustment (page 5-22).**

Force a self-tapping 4 mm screw, (P/N 93903-35410) into the drilled plug and continue turning the screw driver until the plug rotates with the screw.

Pull on the screw head with pliers to remove the plug.

Use compressed air to clean the pilot screw area and remove metal shavings.

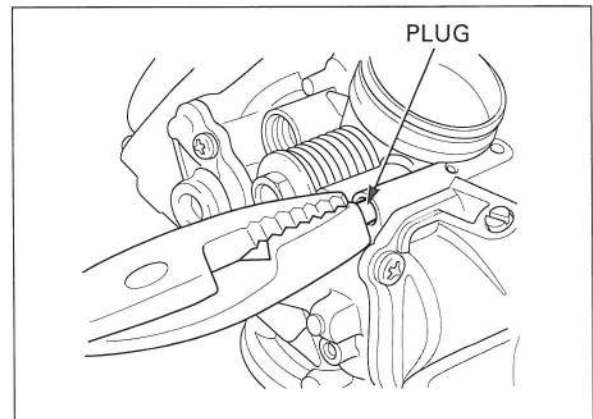
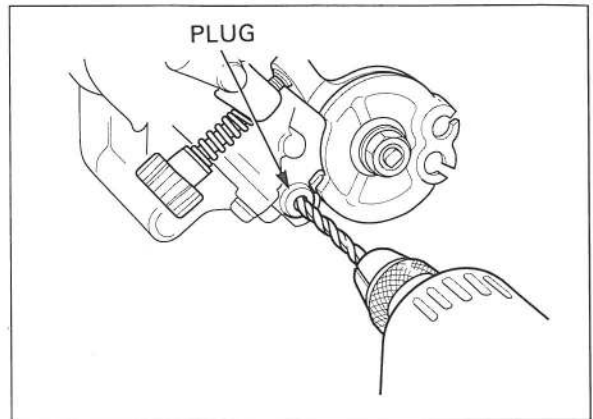

Turn each pilot screw in and carefully count the number of turns until it seats lightly; Make a note of this to use as a reference when reinstalling the pilot screws.

CAUTION:

Damage to the pilot screw seat will occur if the pilot screw is tightened against the seat.

Remove the pilot screw, spring, washer and O-ring.

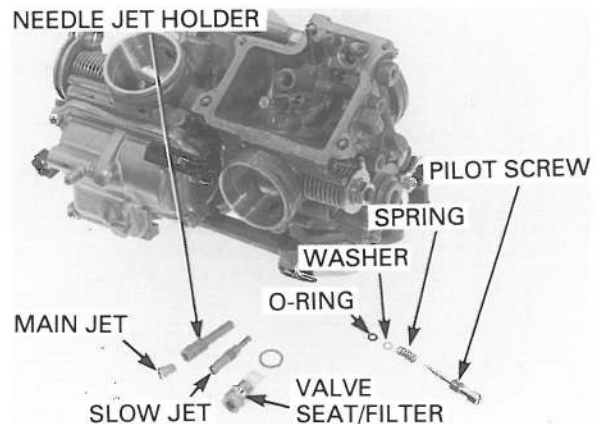

INSPECTION

A worn or contaminated valve does not seat properly and will eventually flood the carburetor.

FLOAT VALVE, VALVE SEAT

Check the float valve and valve seat for scoring, scratches, clogging or damage. Check the tip of the float valve where it contacts the valve seat, for stepped wear or contamination.

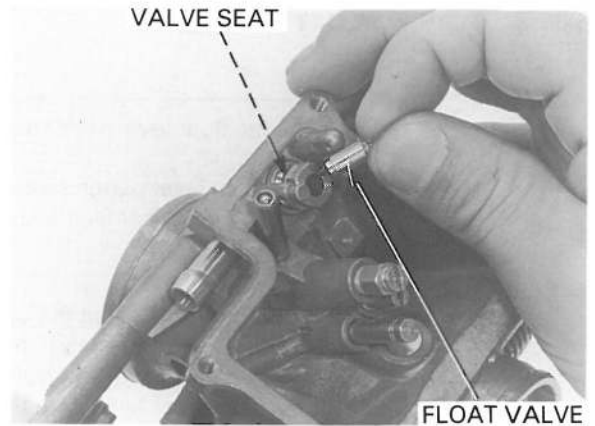

JETS

Check the each jets for wear or damage. Clean the jets with non-flammable or high flash solvent and blow open with compressed air.

VALVE SEAT/FILTER

Check the float valve seat and filter for grooves, nicks or deposits.

PILOT SCREW

Check the pilot screw for stepped wear or damage. Replace these parts if necessary.

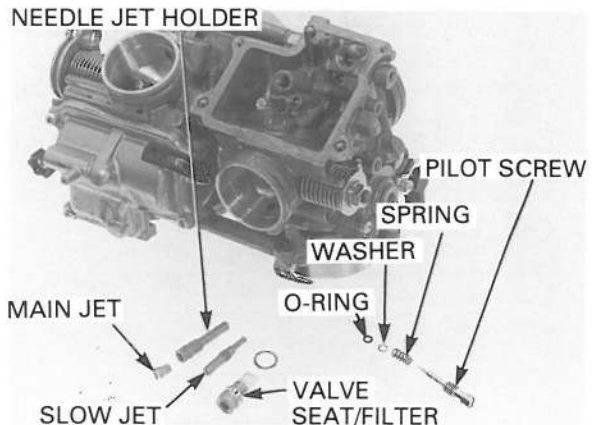

ASSEMBLY

Install the main jet, needle jet holder, slow jet and valve seat/filter. Install the O-ring, washer, spring, pilot screw and new pilot screw plug.

NOTE:

- Install the pilot screw and return it to its original position as noted during removal.
- Perform pilot screw adjustment if new pilot screw is installed (page 5-22).

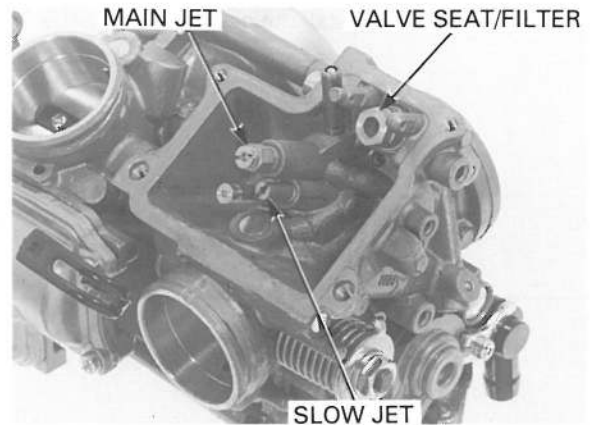

Hang the float valve onto the float arm lip. Install the float valve with the float in the carburetor body, then install the float pin through the body and float.

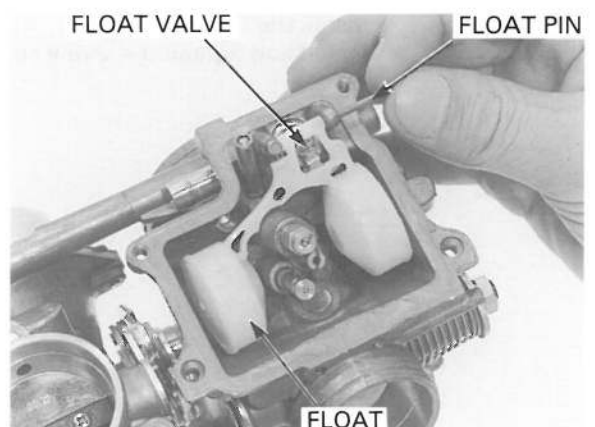

FUEL SYSTEM

FLOAT LEVEL

NOTE:

- Check the float level after checking the float valve and float.
- Set the float level gauge so that it is perpendicular to the float chamber face and in line with the main jet.

Set the carburetor so that the valve just contact the float arm lip. Be sure that the float valve tip is securely in contact with the valve seat. Make sure the float level with the float level gauge.

TOOL:

Carburetor float level gauge: 07401-0010000

FLOAT LEVEL: 7.0 mm (0.28 in)

If the level is out of specification, replace the float.

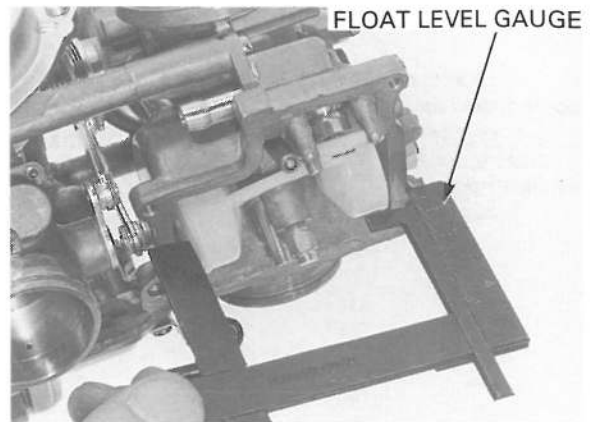

Install the new O-ring into the float chamber groove.

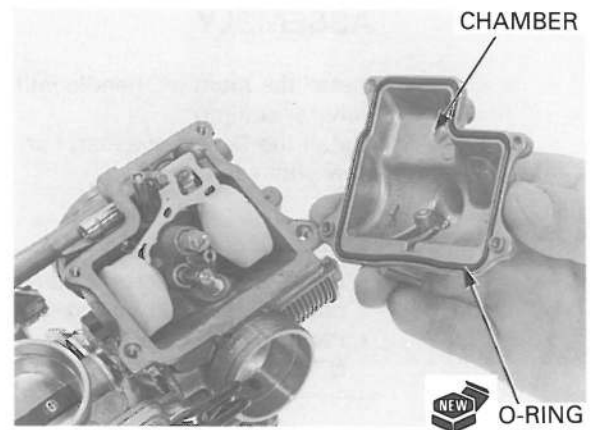

Install the float chamber.
Install and tighten the screw securely.

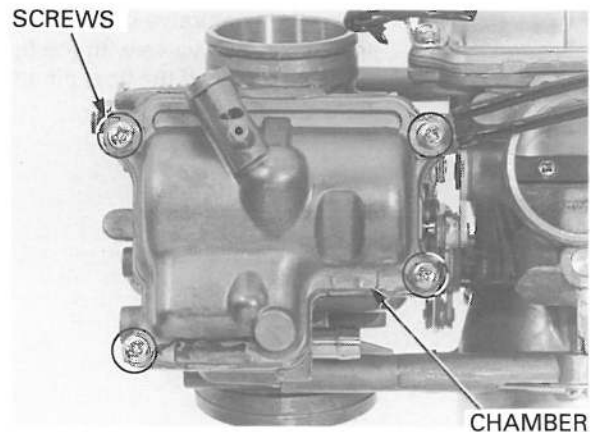

AIR CUT-OFF VALVE

DISASSEMBLY

Remove the two screws, set plate and air cut-off valve cover.

NOTE:

The air cut-off valve cover is under spring pressure. Do not lose the spring and screws.

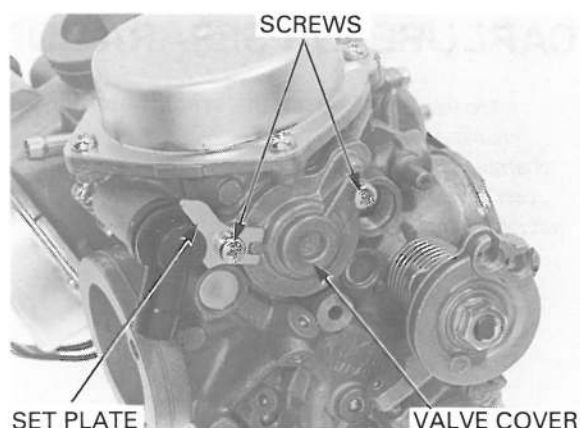

INSPECTION

Check the diaphragm for deterioration, pin hole or other damage.
 Check the spring for deterioration or other damage.
 Check the diaphragm needle for excessive wear at the tip or other damage.
 Check the orifice of air vent for clogging.
 Check the U-ring for damage.

Replace the air cut-off valve as an assembly, if necessary.

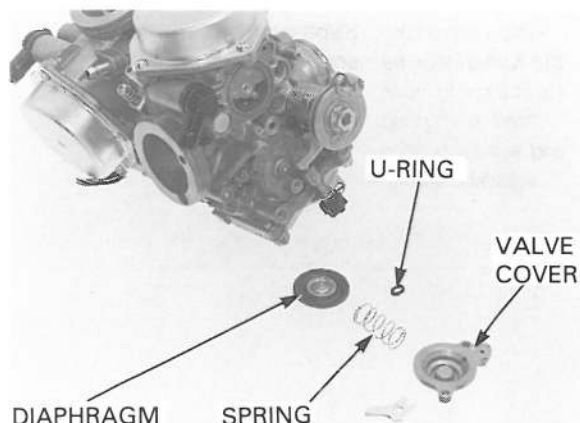

ASSEMBLY

Assembly is in the reverse order of disassembly.

NOTE:

- Install the U-ring with its flat side toward the carburetor body as shown.
- Be careful not to pinch the diaphragm.
- Install the set plate aligning its cut-out with the tab on the valve cover.

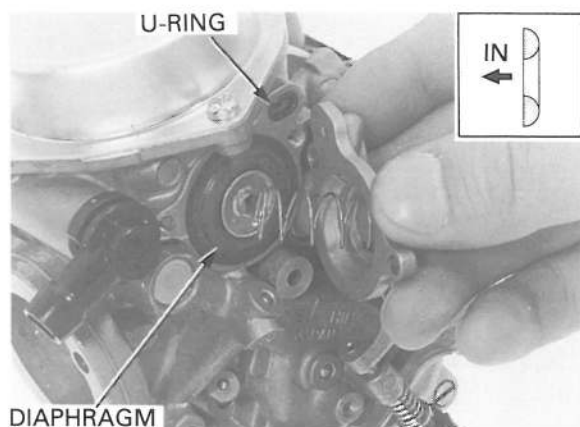

CARBURETOR BODY CLEANING

CAUTION:

- *Cleaning the air and fuel passages with a piece of wire will damage the carburetor body.*
- *Remove the diaphragms to prevent damage to them before using air to blow open passage.*

Disassembled the carburetor (page 5-10).

Blow open all air and fuel passages in the carburetor body with compressed air.

Clean the fuel strainer in the float valve using compressed air from the float valve seat side.

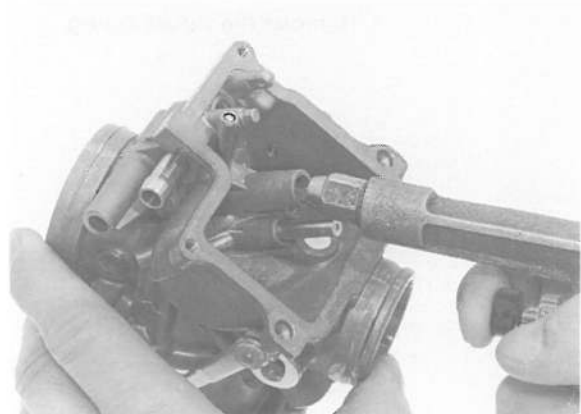

FUEL SYSTEM

CARBURETOR SEPARATION

The vacuum chamber, float chamber and jets can be serviced without separating the carburetors. Loosen the synchronization adjusting screw.



When separating the carburetors, be careful not to lose the thrust spring and synchronization adjusting spring. Separate the carburetors by removing two attaching screws.

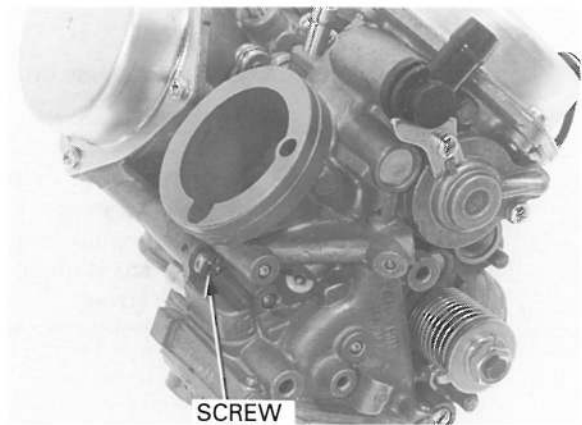
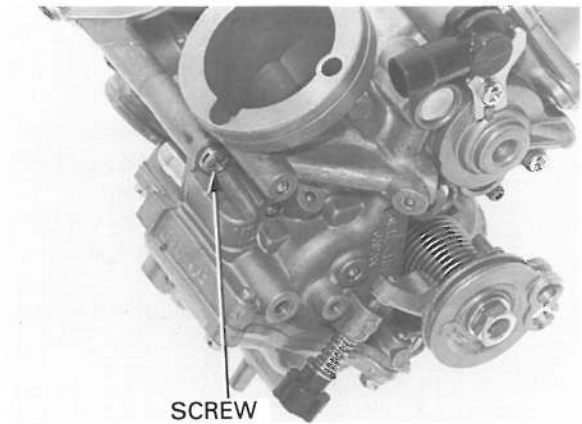

Remove the thrust spring.



CARBURETOR REASSEMBLY

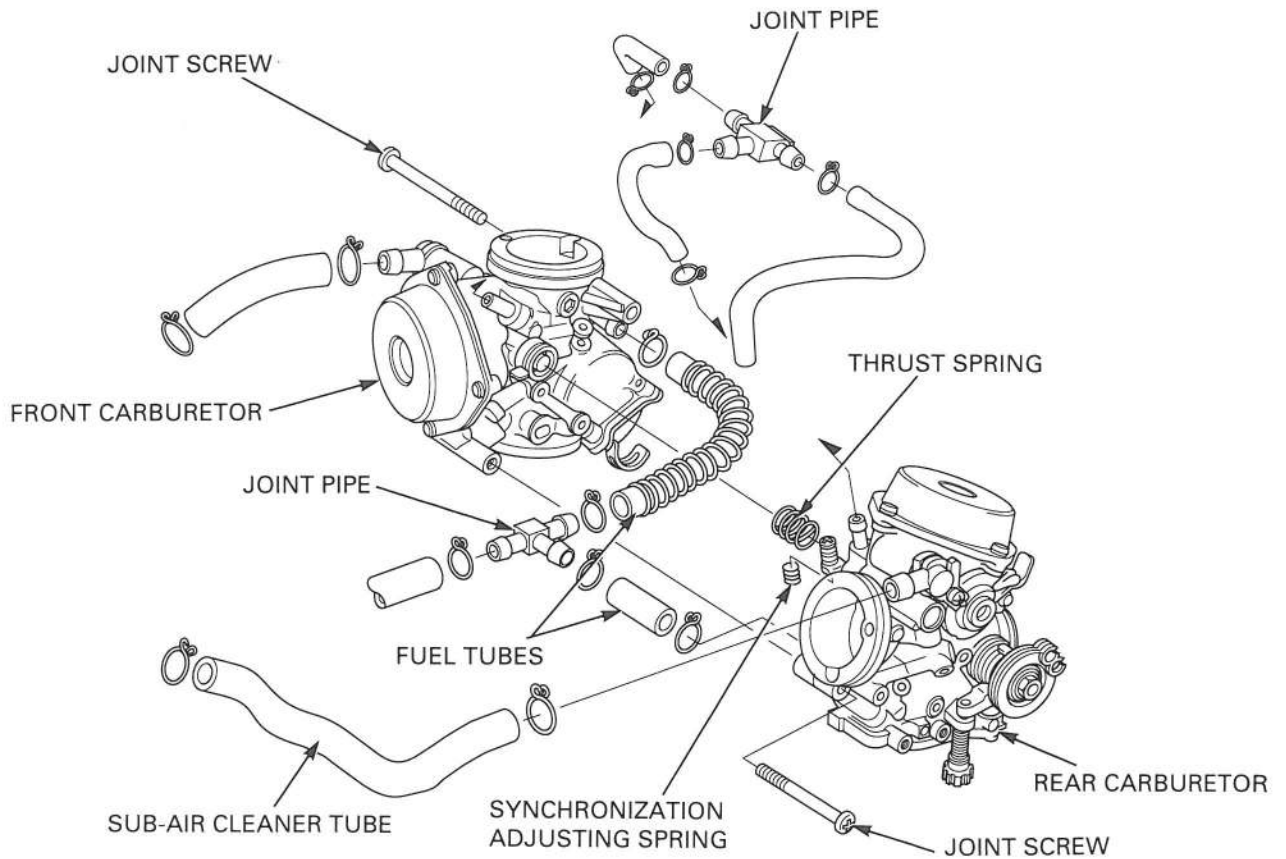

Loosen the synchronization adjusting screw until there is no spring tension.

Install the thrust spring between the throttle links.

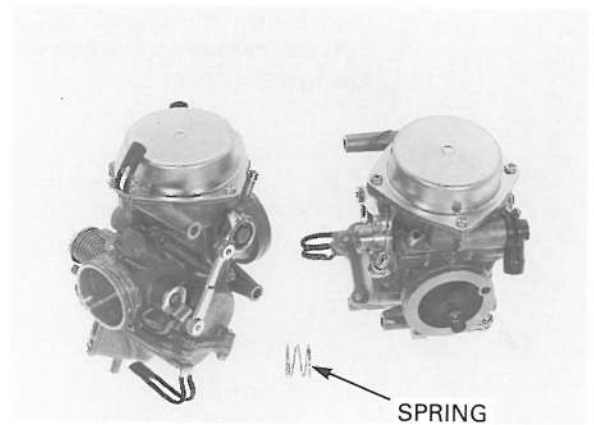

Secure the carburetors together with the two screws.

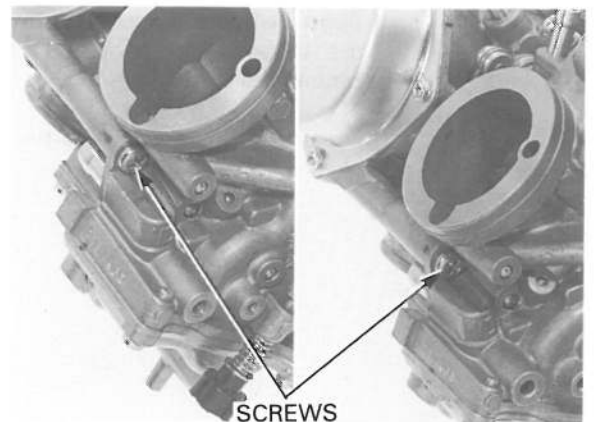

FUEL SYSTEM

Install the synchronization spring and synchronization adjusting screw.

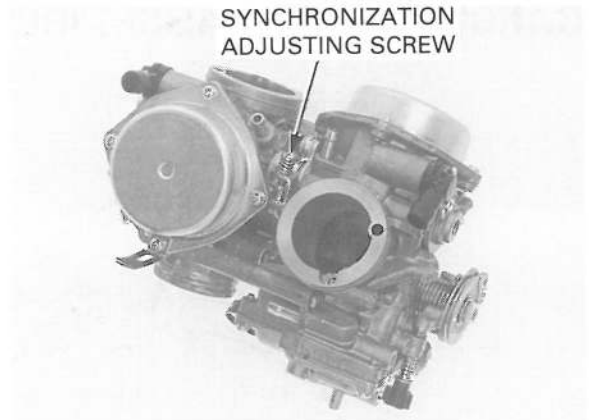

INSPECT THROTTLE OPERATION AS DESCRIBED BELOW:

Open the throttle slightly by rotating the throttle valve, then release the throttle. Make sure that there is no drag when opening and closing the throttle.

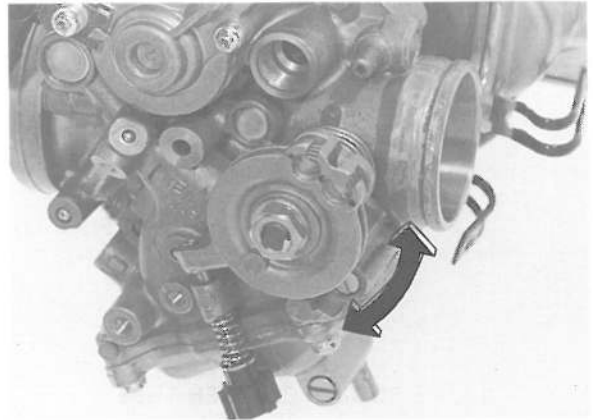

Turn the throttle stop control knob to align the rear cylinder carburetor throttle valve with the edge of the by-pass hole.

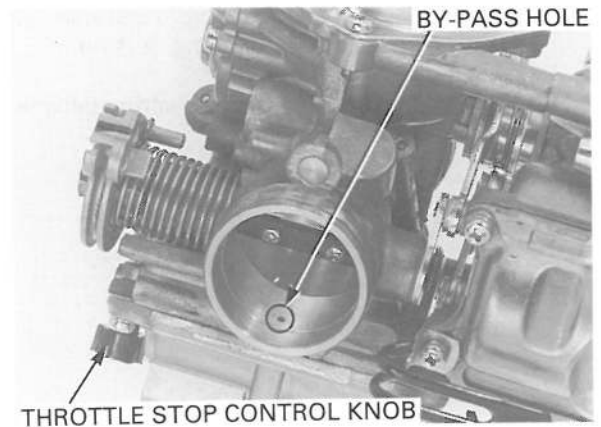

Align the front cylinder carburetor throttle valve with the by-pass hole edge by turning the synchronization adjusting screw.

Make sure the throttle returns smoothly.

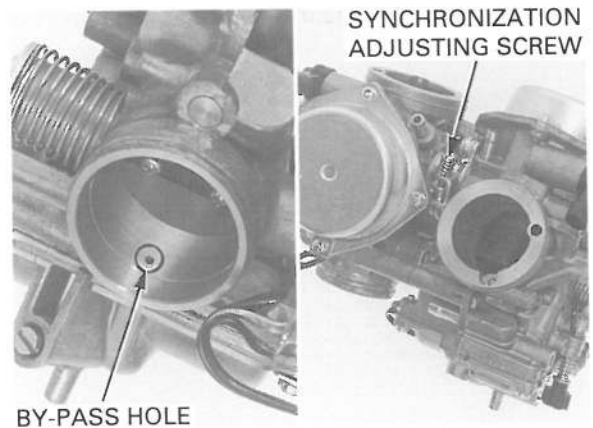

CARBURETOR INSTALLATION

Install the starting enrichment (SE) valve to the carburetor as shown.
Tighten the lock nut securely.

Install the fuel and air tubes (carburetors-to-air cleaner) as shown.

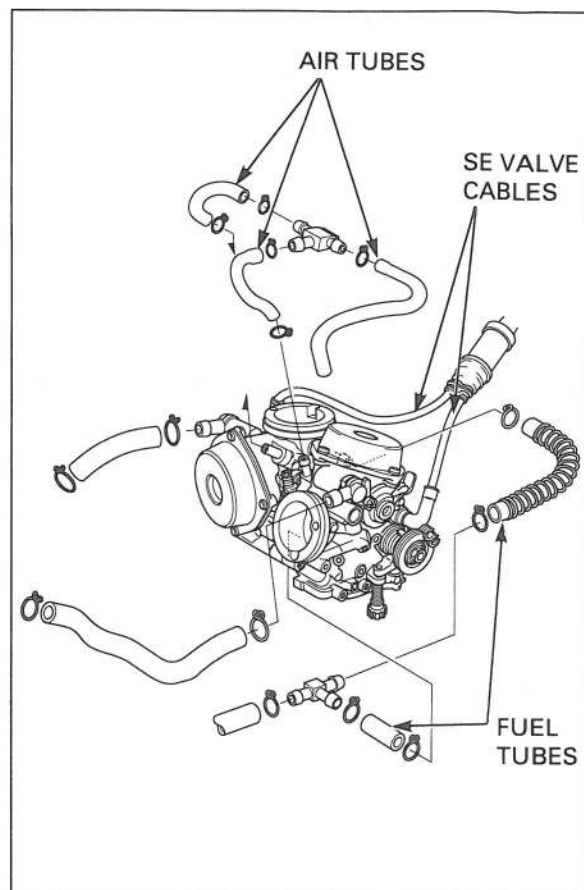

Install the carburetor to the insulator.
Tighten the insulator band screw securely.
Connect the sub-air cleaner tube to the carburetor.

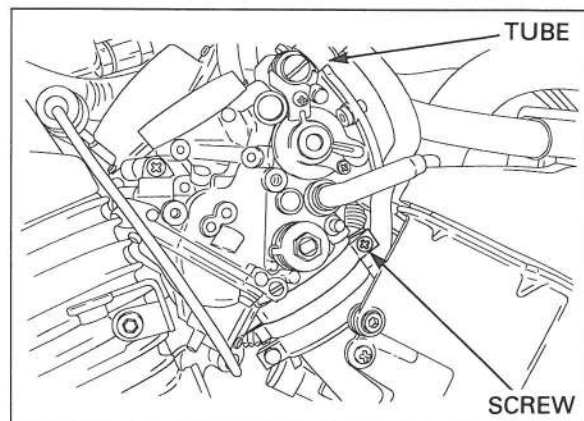

Install the starting enrichment (SE) valve knob and rear cylinder left side fin.
Install and tighten the mounting bolts securely.
Install the spark plug cap.

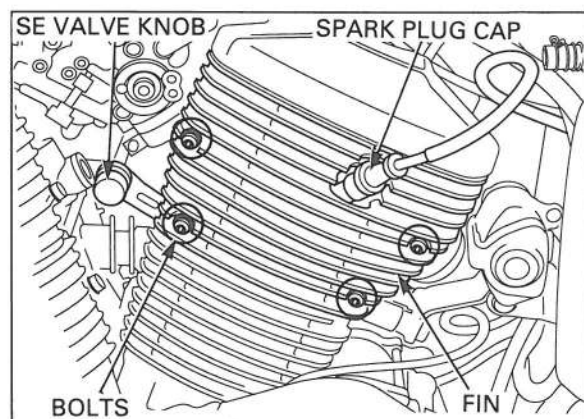

FUEL SYSTEM

Connect the sub-air cleaner tube to the carburetor. Tighten the insulator band screw. Connect the throttle cable to the throttle link. Install the throttle cable holder to the carburetor. Install and tighten the mounting screws securely.

Install the fuel tube onto the clamp. Connect the fuel tube.

Install the following parts:

- Left side cover (page 2-4)
- Air cleaner chamber (page 5-7)
- Air cleaner housing (page 5-4)
- Fuel tank (page 2-4)

Perform the following inspections and adjustment.

- Pilot screw (see below)
- Carburetor synchronization (page 3-14)
- Throttle grip free play (page 3-4)
- Engine idle speed (page 3-15)
- Carburetor choke (page 3-5)

After installation, turn the ignition switch ON and check the fuel line for leakage.

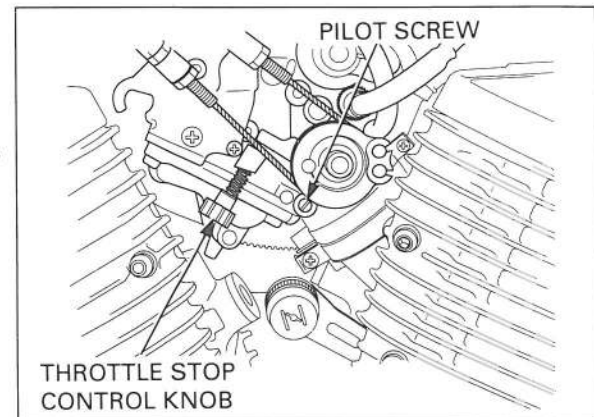
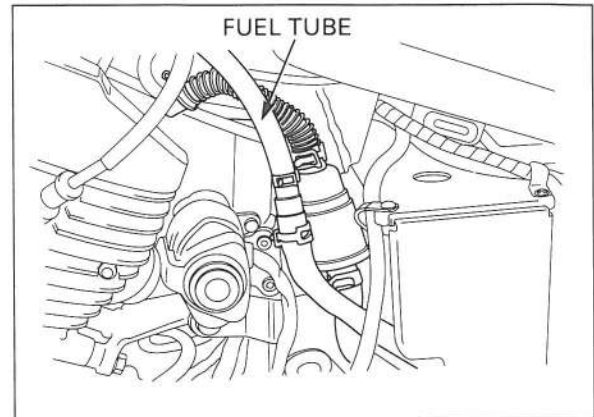
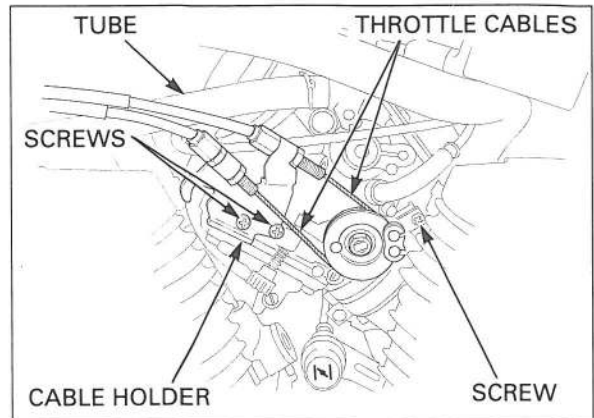

PILOT SCREW ADJUSTMENT

IDLE DROP PROCEDURE

⚠ WARNING

- *If the engine must be running to do some work, make sure the area is well-ventilated. Never run the engine in an enclosed area.*
- *The exhaust contains poisonous carbon monoxide gas that may cause loss of consciousness and may lead to death.*

NOTE:

- Make sure the carburetor synchronization is within specification before pilot screw adjustment (page 3-14).
- The pilot screw is factory pre-set and no adjustment can be done unless it is replaced.
- Use a tachometer with graduations of 50 rpm or smaller that will accurately indicate a 50 rpm change.

1. Remove the pilot screw plugs (page 5-14).
2. Turn each pilot screw clockwise until it seats lightly, then back it out to specification given.

INITIAL OPENING: 2-1/4 turns out

CAUTION:

Damage to the pilot screw seat will occur if the pilot screw is tightened against the seat.

3. Warm up the engine to operating temperature. Stop and go riding for 10 minutes is sufficient.
4. Attach a tachometer according to the manufacturers instructions.
5. Start the engine and adjust the engine idle speed to the specified rpm with the throttle stop control knob.

IDLE SPEED: 1,000 ± 100 rpm

6. Turn each pilot screw 1/2 turn out from the initial setting.
7. If the engine speed increases by 50 rpm or more, turn each pilot screw out by successive 1/2 turn increments until engine speed does not increase.
8. Adjust the idle speed with the throttle stop control knob.
9. Turn the rear cylinder carburetor pilot screw in until the engine speed drops 50 rpm.
10. Turn the rear cylinder carburetor pilot screw counterclockwise to the final opening from the position in step 9.

FINAL OPENING: 1 turn out

11. Adjust the idle speed with the throttle stop control knob.
12. Perform steps 9,10 and 11 for the front cylinder carburetor pilot screw.
13. Drive new pilot screw plugs into the pilot screw bores with a 7 mm valve guide driver (P/N 07942-8230000 or 07942-6570100). When fully seated, the plug surfaces will be recessed 1 mm.

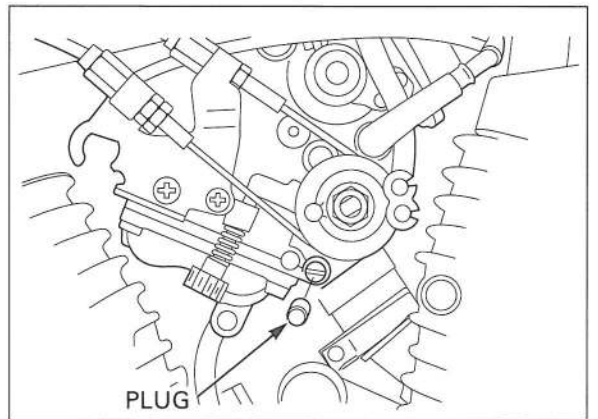
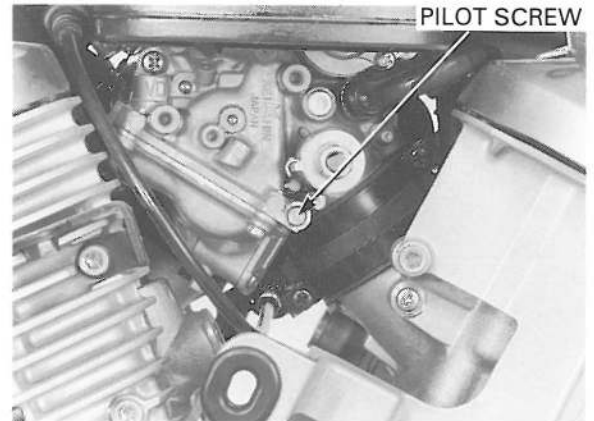
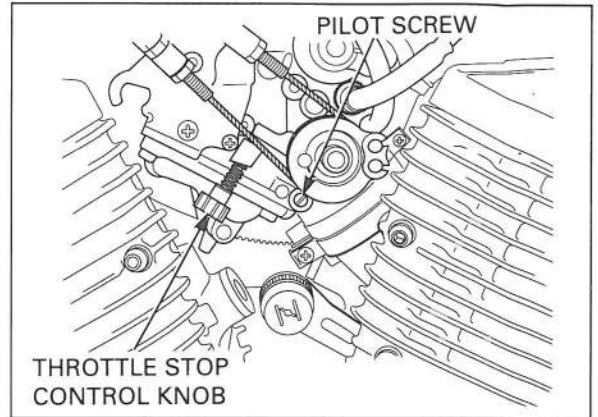

FUEL SYSTEM

FUEL PUMP

⚠ WARNING

Gasoline is extremely flammable and is explosive under certain conditions. KEEP OUT OF REACH OF CHILDREN.

SYSTEM INSPECTION

Remove the right side cover (page 2-4).

Turn the ignition switch OFF.
Disconnect the fuel cut relay 3P connector and connect the voltmeter at the 3P connector wire harness side.

CONNECTION: Black (+) – body ground (-)

Turn the ignition switch ON.
There should be battery voltage.
If there is no voltage, check for an open circuit or loose connection in Black wire.
If there is battery voltage, check for continuity in the Black/Blue wire.

Check for continuity between the Black/Blue wire and ground at the 3P connector wire harness side.

CONNECTION: Black/Blue – body ground
STANDARD: No continuity

If there is continuity, replace the fuel cut relay.

If there is no continuity, short the terminals of the 3P connector wire harness side with the suitable jumper wire.

SHORT TERMINALS: Black/Blue – Black

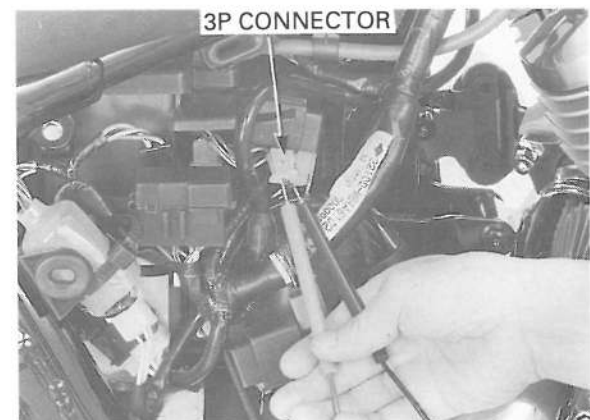
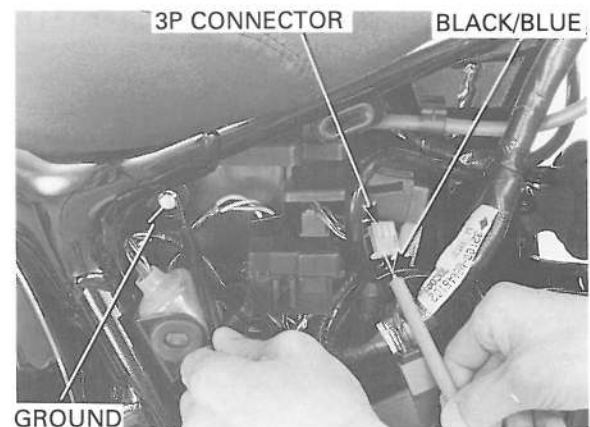
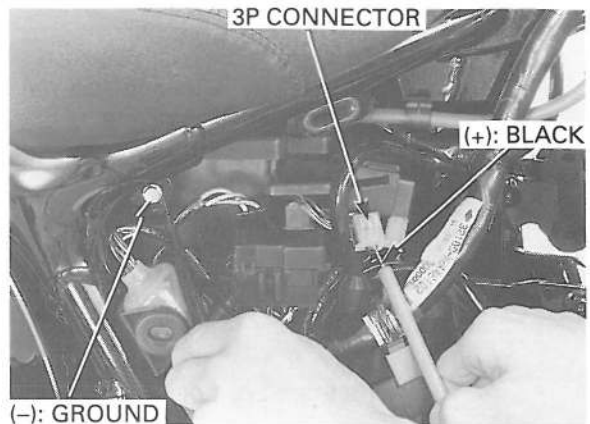

Disconnect the fuel pump 2P (White) connector and connect the voltmeter at the 2P (White) connector wire harness side.

CONNECTION: Black/Blue (+) – Green (-)

Turn the ignition switch ON and measure the voltage at the 2P (White) connector.

STANDARD: Battery voltage

If there is no voltage, check for an open circuit or loose connection in Black/Blue and Green wires. If there is battery voltage, replace the fuel pump.

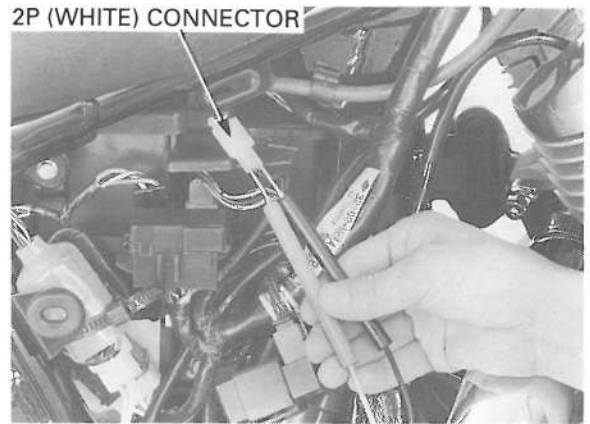

DISCHARGE VOLUME INSPECTION

Remove the right and left side covers (page 2-4).

Disconnect the fuel cut relay 3P connector. Short the Black and Black/Blue terminals with a suitable jumper wire.

Disconnect the fuel pump outlet tube from the tube joint.

Hold a graduated beaker under the fuel pump outlet tube.

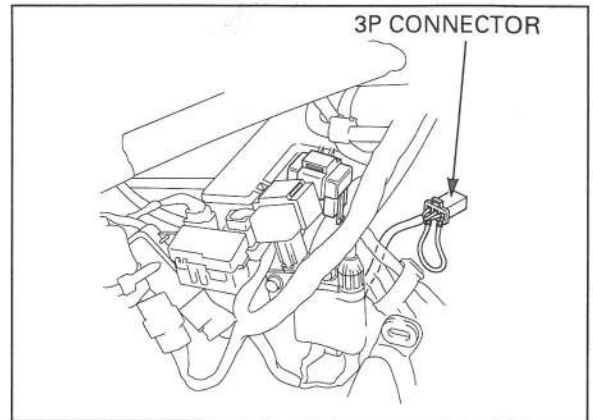

Turn the ignition switch ON and let the fuel flow into the beaker for 5 seconds, then turn the ignition switch OFF.

Multiply the amount in the beaker by 12 to determine the fuel pump flow capacity per minute.

**FUEL PUMP FLOW CAPACITY:
900 cm³ (30.4 US oz, 31.7 Imp oz) min./minute**

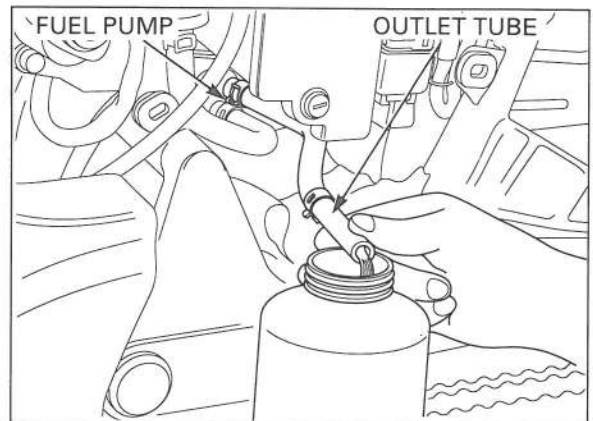

REMOVAL

Remove the right and left side covers (page 2-4).

Disconnect the fuel pump 2P (White) connector and remove the fuel pump wire from the clamps.

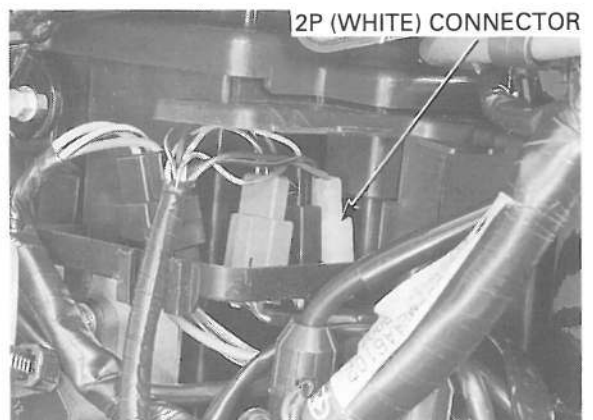

FUEL SYSTEM

Disconnect the fuel tubes (pump-to-filter, pump-to-carburetor).

Disconnect the fuel pump tube.
Remove the fuel pump from the pump bracket.

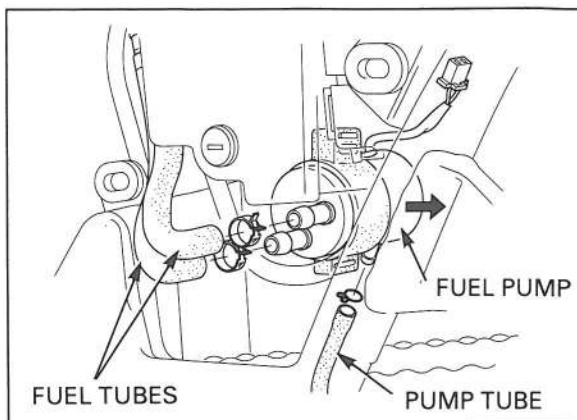

INSTALLATION

Route the wire harness and tubes properly (page 1-22).

Connect the fuel pump tube to the fuel pump.
Install the fuel pump to the pump bracket.
Connect the fuel tubes (pump-to-filter, pump-to-carburetor).

NOTE:

Connect the pump-to-filler fuel tube to the fuel pump "IN" marked side.

Connect the fuel pump 2P (White) connector and install the fuel pump wire to the clamps.

Install the right and left side covers (page 2-4).

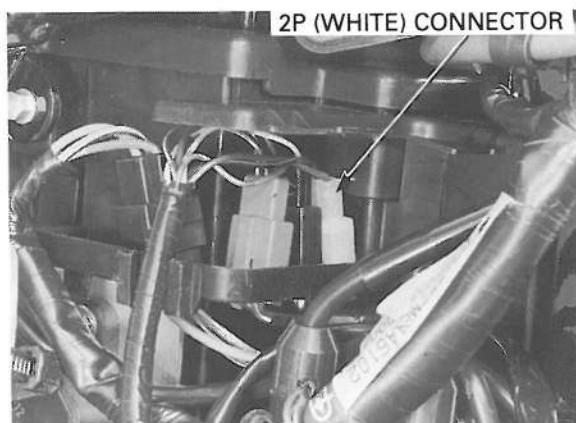
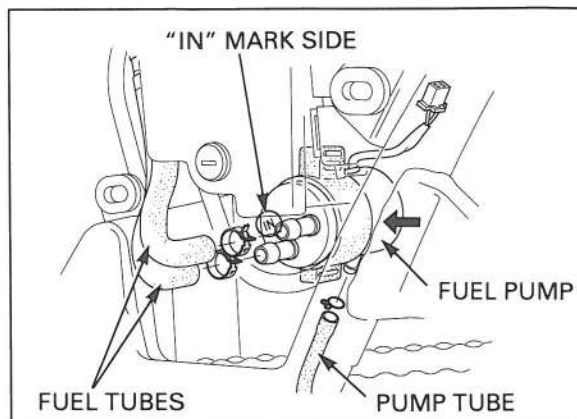

FUEL FILTER

REMOVAL

Remove the left side cover (page 2-4).

Disconnect the fuel tube (pump-to-filter).
Remove the fuel filter and rubber cushion from the filter bracket.

Disconnect the fuel tubes from the fuel filter.
Remove the rubber cushion from the fuel filter.

Check the fuel filter for damage or contamination.
Replace the fuel filter if necessary.

INSTALLATION

Installation is in the reverse order of removal.

NOTE:

At fuel filter and rubber cushion installation, install the filter with the "⇒" mark facing the fuel pump.

Install the left side coner (page 2-4).

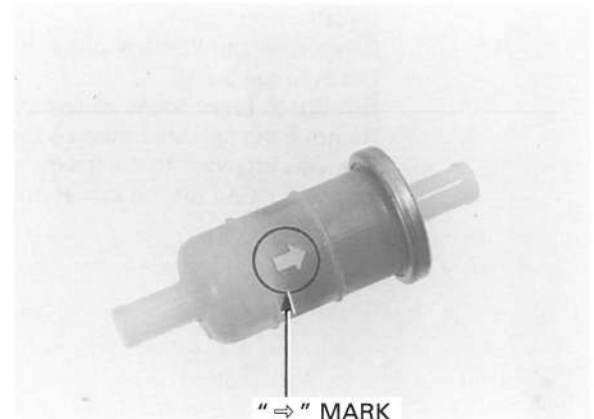
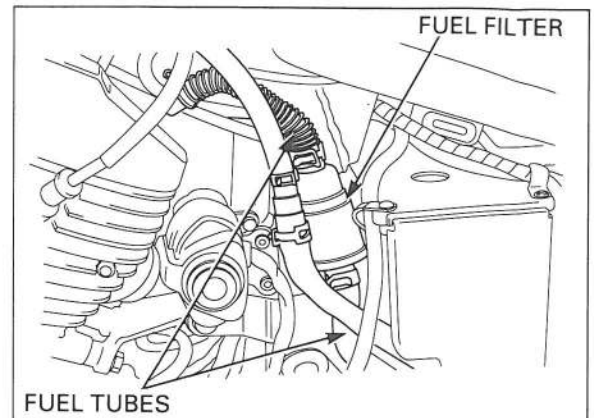

HIGH ALTITUDE ADJUSTMENT (U.S.A. ONLY)

When the vehicle is to be operated continuously above 2,000 m (6,500 feet) the carburetors must be readjusted as follows to improve driveability and decrease exhaust emissions.

Remove each pilot screw plugs (page 5-14).
Warm up the engine to operating temperature. Stop and go driving 10 minutes is sufficient.
Turn each pilot screw plugs to the specification below.

HIGH ALTITUDE SETTING: 1/2 turn in

Adjust the idle speed to $1,000 \pm 100$ rpm, with the throttle stop screw.
Drive new pilot screw plugs into the pilot screw bores (page 5-23).

NOTE

This adjustment must be made at high altitude to ensure proper high altitude operation.

Do not attach the label to any part that can be easily removed from the vehicle.

Attach a Vehicle Emission Control Information update label onto the inside of the left side cover as shown. See SL#132 for information on obtaining the label.

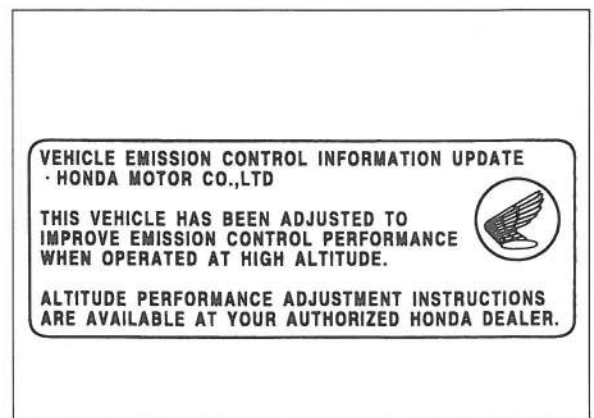
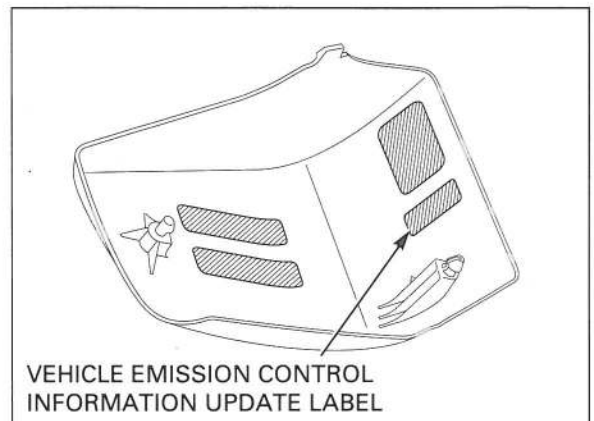

FUEL SYSTEM

⚠ WARNING

Sustained operation at an altitude lower than 1,500 m (5,000 feet) with the carburetors adjusted for high altitude may cause the engine to idle roughly and engine may stall in traffic and may cause engine damage due to overheating.

When the vehicle is to be operated continuously below 1,500 m (5,000 feet), turn each pilot screw to the specification below, its original position.

LOW ALTITUDE SETTING: 1/2 turn out from high altitude setting

Adjust the idle speed to $1,000 \pm 100$ rpm with the throttle stop screw.

Drive new pilot screw plugs into the pilot screw bores (page 5-23).

Be sure to make these adjustments at low altitude. Remove the Vehicle Emission Control Update Label that was attached to the inside of the left side cover after adjusting for the low altitude.

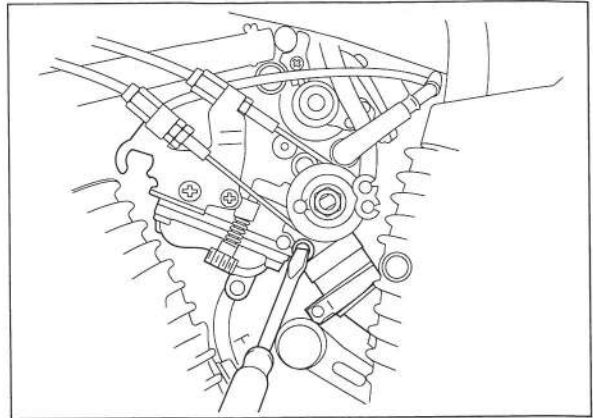

EVAPORATIVE EMISSION PURGE CONTROL VALVE INSPECTION (CALIFORNIA TYPE ONLY)

The evaporative emission purge control valve should be inspected if hot restart is difficult.

Check the fuel tank, Evaporative Emission Purge Control Valve (EVAP PURGE CONTROL VALVE), and evaporative emission canister hoses to be sure they are not kinked and are securely connected. Replace any hose that shows signs of damage or deterioration.

The EVAP PURGE CONTROL VALVE is located under the fuel tank.

Disconnect the EVAP PURGE CONTROL VALVE hoses from their connections and remove the EVAP PURGE CONTROL VALVE from its mount. Refer to the routing label on the inside of the left side cover for hose connections.

Connect a vacuum pump to the 8 mm (0.31 in) I.D. hose No.5 that goes to the 3-way joint. Apply the specified vacuum to the EVAP PURGE CONTROL VALVE.

SPECIFIED VACUUM: 250 mm (9.8 in) Hg

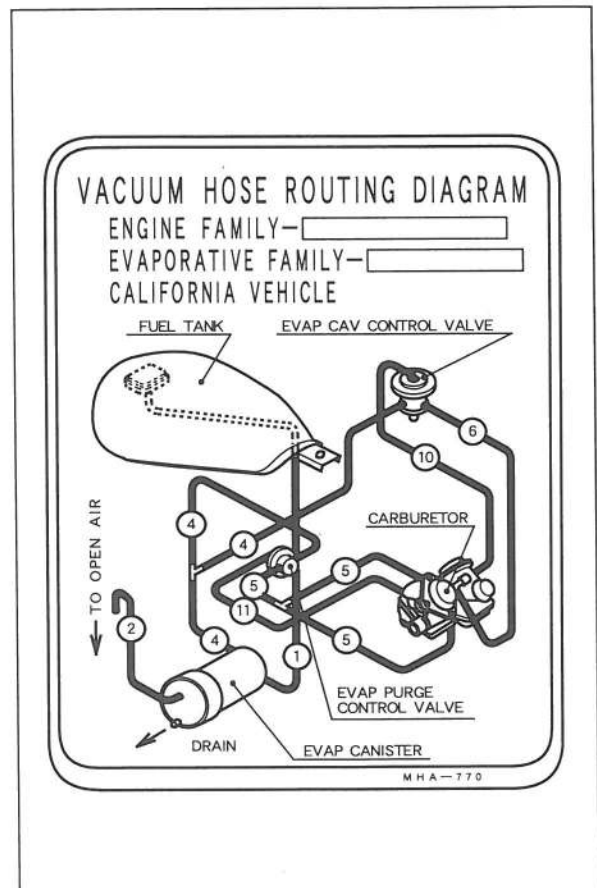

The specified vacuum should be maintained. Replace the EVAP PURGE CONTROL VALVE if vacuum is not maintained.

TOOL:
Vacuum/pressure pump A937-041-XXXXX or
Vacuum pump ST-AH-260-MC7
 (U.S.A. only)

Remove the vacuum pump and connect it to the vacuum hose No.11 that goes to the left carburetor body. Apply the specified vacuum to the EVAP PURGE CONTROL VALVE.

SPECIFIED VACUUM: 250 mm (9.8 in) Hg

The specified vacuum should be maintained. Replace the EVAP PURGE CONTROL VALVE if vacuum is not maintained.

TOOL:
Vacuum/pressure pump A937-041-XXXXX or
Vacuum pump ST-AH-260-MC7
 (U.S.A. only)

Connect a pressure pump to the 8 mm (0.31 in) I.D. hose No.4 that goes to the evaporative emission canister. While applying the specified vacuum to the EVAP PURGE CONTROL VALVE hose that goes to the 3-way joint pump air through the evaporative emission canister hose. Air should flow through the EVAP PURGE CONTROL VALVE and out the hose that goes to the 3-way joint. Replace the EVAP PURGE CONTROL VALVE if air does not flow out.

CAUTION:

To prevent damage to the evaporative emission purge control valve, do not use high air pressure sources. Use a hand operated air pump only.

TOOL:
Vacuum/pressure pump A937-041-XXXXX or
Vacuum pump ST-AH-260-MC7
Pressure pump ST-AH-255-MC7
 (U.S.A. only)

Remove the pumps, install the EVAP PURGE CONTROL VALVE on its mount, route and reconnect the hose according to the routing label.

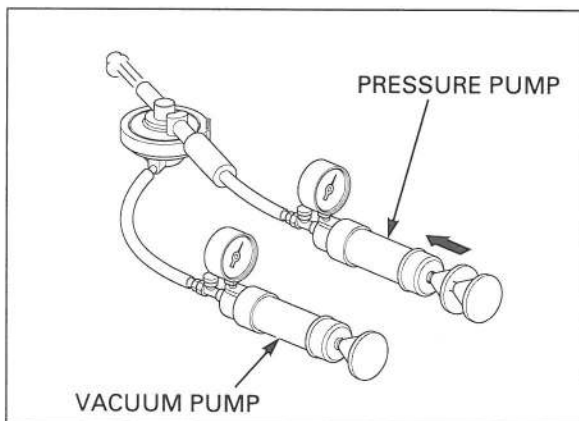
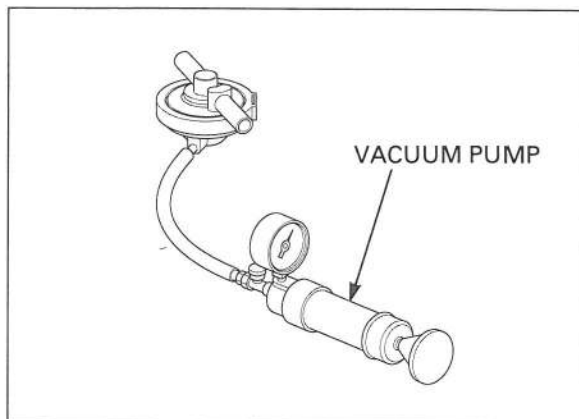
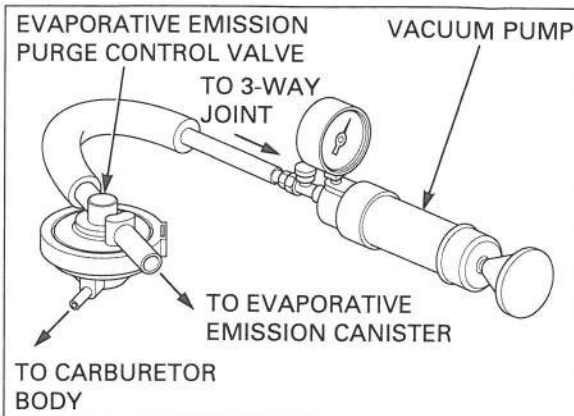

EVAPORATIVE EMISSION CARBURETOR AIR VENT CONTROL VALVE INSPECTION (CALIFORNIA TYPE ONLY)

Disconnect the Evaporative Emission Carburetor Air Vent Control Valve (EVAP CAV CONTROL VALVE) hoses from their connections and remove the EVAP CAV CONTROL VALVE from its mount. Refer to the routing label on left side cover for hose connections. Connect a vacuum pump to the No.10 hose that goes to the right carburetor body. Apply the specified vacuum to the EVAP CAV CONTROL VALVE.

SPECIFIED VACUUM: 250 mm (9.8 in) Hg

TOOL:

Vacuum/pressure pump	A937-041-XXXXX or
Vacuum pump	ST-AH-260-MC7
	(U.S.A. only)

The specified vacuum should be maintained. Replace the EVAP CAV CONTROL VALVE if vacuum is not maintained.

CAUTION:

To prevent damage to the evaporative emission carburetor air vent control valve, do not use high air pressure sources. Use a hand operated air pump only.

Connect the vacuum pump to the air vent port of the EVAP CAV CONTROL VALVE. Apply vacuum to the EVAP CAV CONTROL VALVE. The vacuum should hold steady. Replace the EVAP CAV CONTROL VALVE if vacuum leaks.

TOOL:

Vacuum/pressure pump	A937-041-XXXXX or
Vacuum pump	ST-AH-260-MC7
	(U.S.A. only)

Connect the vacuum pump to the No.10 hose that goes to the right carburetor body. Connect the pressure pump to the air vent port of the EVAP CAV CONTROL VALVE. While applying the vacuum to the EVAP CAV CONTROL VALVE No.10 hose that goes to the right carburetor body, pump air through the EVAP CAV CONTROL VALVE and out the hose that goes to the carburetor air joint pipe.

TOOL:

Vacuum/pressure pump	A937-041-XXXXX or
Vacuum pump	ST-AH-260-MC7
Pressure pump	ST-AH-255-MC7

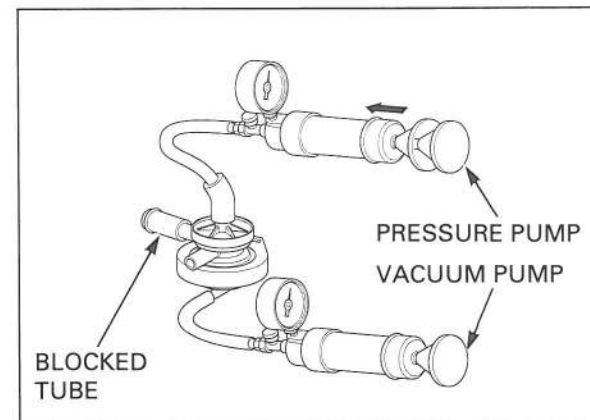
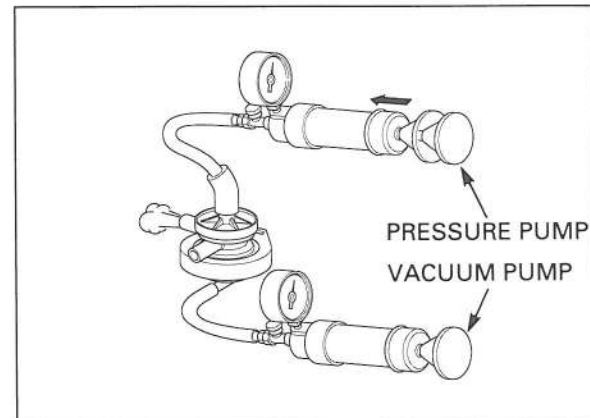
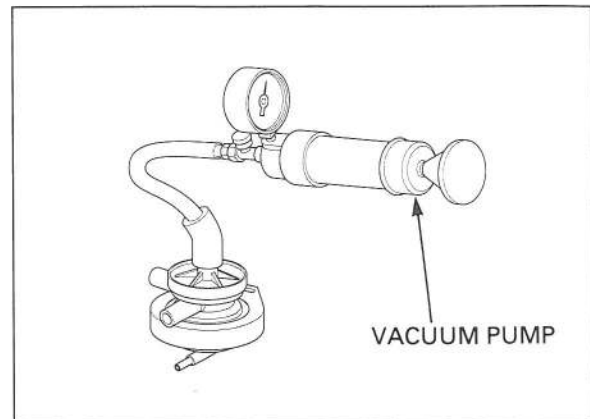
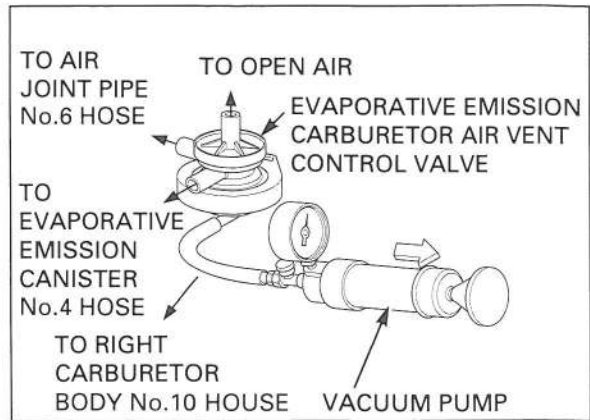

Plug the hose that goes to the carburetor air joint pipe.

While applying vacuum to the EVAP CAV CONTROL VALVE No. 10 hose that goes to the right carburetor body, apply air pressure.

Remove the pumps, install the EVAP CAV CONTROL VALVE on its mount, route and reconnect the hoses according to the routing label.

TOOL:

Vacuum/pressure pump	A937-041-XXXXX or
Vacuum pump	ST-AH-260-MC7
Pressure pump	ST-AH-255-MC7

SYSTEM FLOW PATTERN

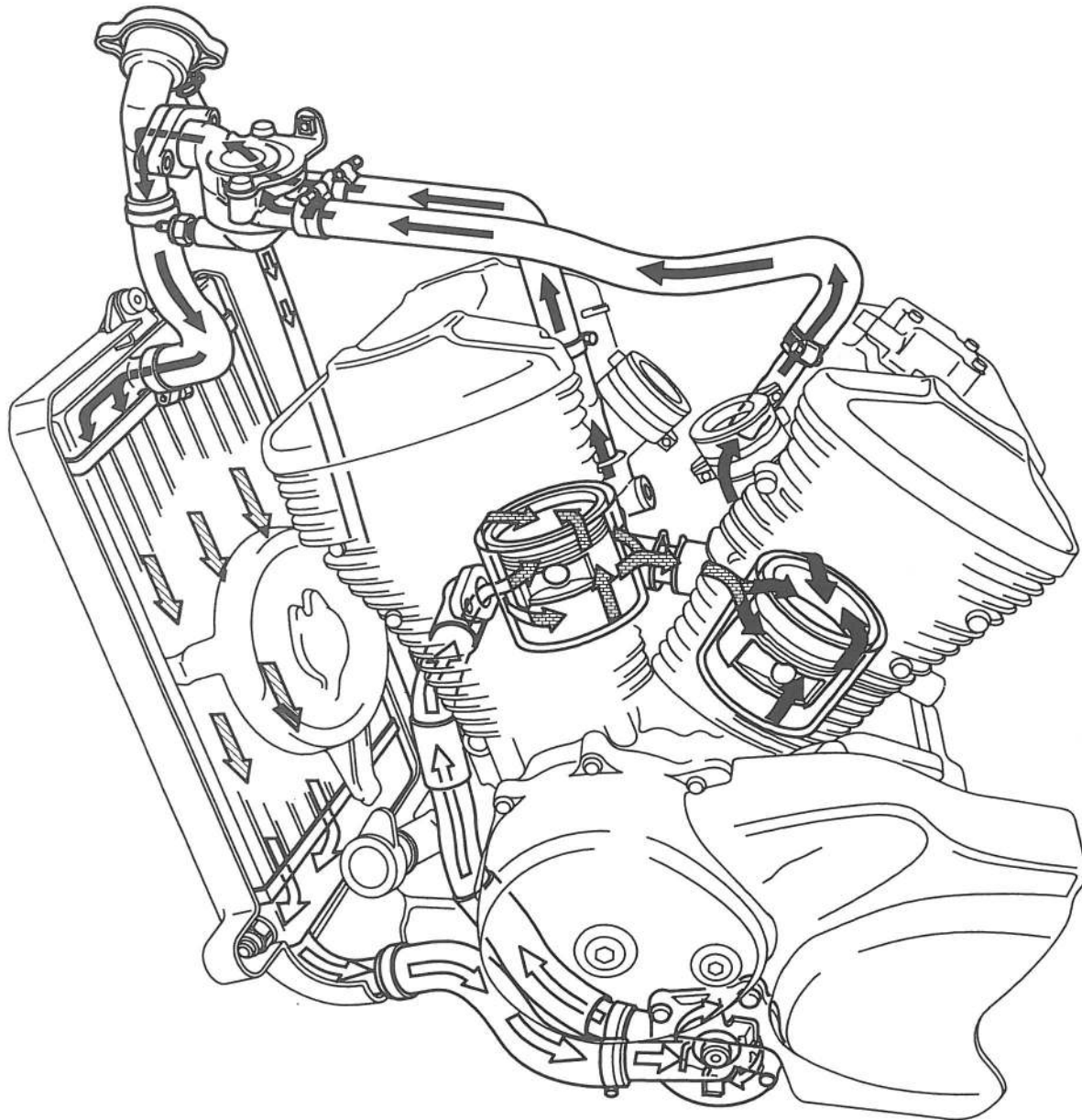

6. COOLING SYSTEM

SYSTEM FLOW PATTERN	6-0	THERMOSTAT	6-6
SERVICE INFORMATION	6-1	RADIATOR/COOLING FAN	6-9
TROUBLESHOOTING	6-2	WATER PUMP	6-15
SYSTEM TESTING	6-3	RADIATOR RESERVE TANK	6-18
COOLANT	6-4		

SERVICE INFORMATION

GENERAL

6

⚠ WARNING

- *Wait until the engine is cool before slowly removing the radiator cap. Removing the cap while the engine is hot and the coolant is under pressure may cause serious scalding.*
- *Radiator coolant is toxic. Keep it away from eyes, mouth, skin and clothes.*
 - *If any coolant gets in your eyes, rinse them with water and consult a doctor immediately.*
 - *If any coolant is swallowed, induce vomiting, gargle and consult a physician immediately.*
 - *If any coolant gets on your skin or clothes, rinse thoroughly with plenty of water.*
- **KEEP OUT OF REACH OF CHILDREN.**

CAUTION :

Using Coolant with silicate inhibitors may cause premature wear of water pump seals or blockage of radiator passages. Using tap water may cause engine damage.

- Add coolant at the reserve tank. Do not remove the radiator cap except to refill or drain the system.
- All cooling system services can be done with the engine in the frame.
- Avoid spilling coolant on painted surfaces.
- After servicing the system, check for leaks with a cooling system tester.
- Refer to Section 19 for fan motor switch and thermo switch inspection.

SPECIFICATIONS

ITEM		SPECIFICATIONS
Coolant capacity	Radiator and engine	1.75 liter (1.85 US qt, 1.54 Imp qt)
	Reserve tank	0.4 liter (0.42 US qt, 0.35 Imp qt)
Radiator cap relief pressure		108 – 137 kPa (1.1 – 1.4 kgf/cm ² , 16 – 20 psi)
Thermostat	Begins to open	80 – 84 °C/176 – 183 °F
	Fully open	95 °C (203 °F)
	Valve lift	8 mm (0.3 in) minimum
Recommended antifreeze		Pro Honda HP Coolant or an equivalent high quality ethylene glycol antifreeze containing corrosion protection inhibitors
Standard coolant concentration		50% mixture with soft water

COOLING SYSTEM

TORQUE VALUES

Radiator mounting bolt	2 N•m (0.2 kgf•m, 1.4 lbf•ft)	
Radiator coolant drain bolt	13 N•m (1.3 kgf•m, 9 lbf•ft)	
Fan motor bolt	3 N•m (0.3 kgf•m, 2.2 lbf•ft)	
Cooling fan nut	3 N•m (0.3 kgf•m, 2.2 lbf•ft)	
Radiator filler bolt	9 N•m (0.9 kgf•m, 6.5 lbf•ft)	
Thermostat housing cover bolt	9 N•m (0.9 kgf•m, 6.5 lbf•ft)	
Fan motor switch	8 N•m (0.8 kgf•m, 5.8 lbf•ft)	Apply sealant to the threads
Water pump cover bolt	13 N•m (1.3 kgf•m, 9 lbf•ft)	

TROUBLESHOOTING

Engine temperature too high

- Faulty temperature gauge or thermo switch (Section 19)
- Faulty radiator cap
- Insufficient coolant
- Passages blocked in radiator, hoses or water jacket
- Air in system
- Faulty water pump
- Thermostat stuck closed
- Faulty cooling fan motor
- Faulty fan motor switch

Engine temperature too low

- Faulty temperature gauge or thermo switch (Section 19)
- Thermostat stuck open
- Faulty cooling fan motor switch

Coolant leaks

- Faulty water pump mechanical seal
- Deteriorated O-ring
- Damaged or deteriorated gasket
- Loose hose connection or clamp
- Damaged or deteriorated hose
- Faulty radiator cap

SYSTEM TESTING

COOLANT (HYDROMETER TEST)

⚠ WARNING

Be sure the engine is cool before removing the cap or you may be severely scalded.

Remove the fuel tank (page 2-4).
Remove the steering covers (page 2-3).

Remove the radiator cap.

Check the coolant gravity using a hydrometer.

STANDARD COOLANT CONCENTRATION: 50 %

Look for contamination and replace the coolant if necessary.

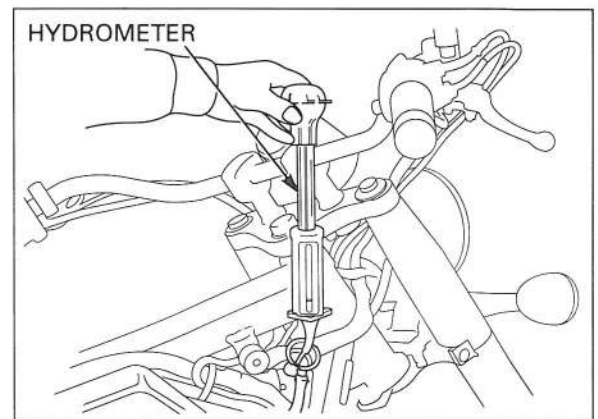

Coolant gravity chart

Coolant temperature °C (°F)	0 (32)	5 (41)	10 (50)	15 (59)	20 (68)	25 (77)	30 (86)	35 (95)	40 (104)	45 (113)	50 (122)
Coolant ratio %											
5	1.009	1.009	1.008	1.008	1.007	1.006	1.005	1.003	1.001	0.999	0.997
10	1.018	1.017	1.017	1.016	1.015	1.014	1.013	1.011	1.009	1.007	1.005
15	1.028	1.027	1.026	1.025	1.024	1.022	1.020	1.018	1.016	1.014	1.012
20	1.036	1.035	1.034	1.033	1.031	1.029	1.027	1.025	1.023	1.021	1.019
25	1.045	1.044	1.043	1.042	1.040	1.038	1.036	1.034	1.031	1.028	1.025
30	1.053	1.052	1.051	1.049	1.047	1.045	1.043	1.041	1.038	1.035	1.032
35	1.063	1.062	1.060	1.058	1.056	1.054	1.052	1.049	1.046	1.043	1.040
40	1.072	1.070	1.068	1.066	1.064	1.062	1.059	1.056	1.053	1.050	1.047
45	1.080	1.078	1.076	1.074	1.072	1.069	1.066	1.063	1.060	1.057	1.054
50	1.086	1.084	1.082	1.080	1.077	1.074	1.071	1.068	1.065	1.062	1.059
55	1.095	1.093	1.091	1.088	1.085	1.082	1.079	1.076	1.073	1.070	1.067
60	1.100	1.098	1.095	1.092	1.089	1.086	1.083	1.080	1.077	1.074	1.071

COOLING SYSTEM

RADIATOR CAP/SYSTEM PRESSURE INSPECTION

⚠ WARNING

The engine must be cool before removing the radiator cap, or severe scalding may result.

Remove the fuel tank (page 2-4).
Remove the steering covers (page 2-3).
Remove the radiator cap.

COOLING SYSTEM TESTER
COMMERCIALY AVAILABLE

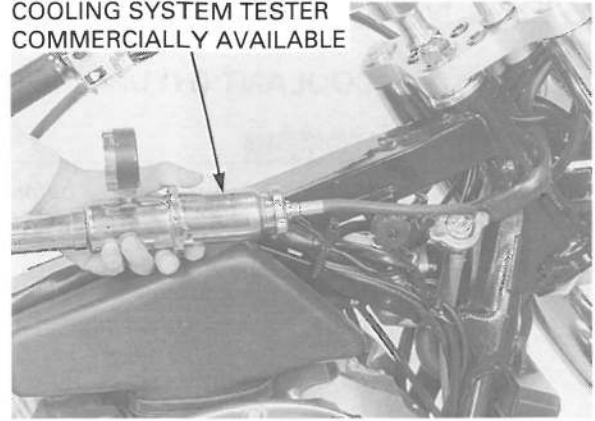

Before installing the cap in the tester, wet the sealing surface.

Pressure test the radiator cap. Replace the radiator cap if does not hold pressure, or if relief pressure is too high or too low. It must hold specified pressure for at least 6 seconds.

RADIATOR CAP RELIEF PRESSURE:
108 – 137 kPa (1.1 – 1.4 kgf/cm², 16 – 20 psi)

Pressure the radiator, engine and hoses, and check for leaks.

CAUTION:

Excessive pressure can damage the cooling system components. Do not exceed 137 kPa (1.4 kgf/cm², 20 psi).

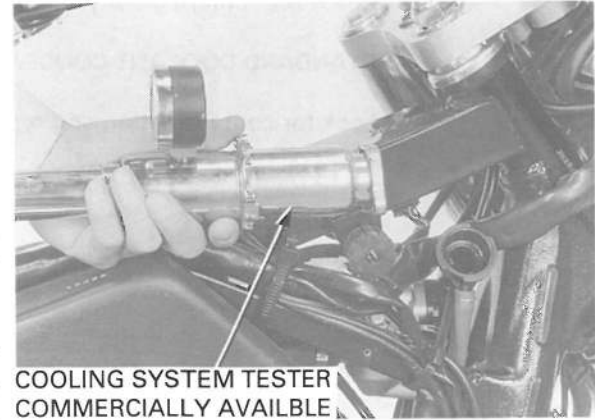

COOLING SYSTEM TESTER
COMMERCIALY AVAILABLE

Check the following components if the system will not hold specified pressure for at least 6 seconds.

- All hose and connections
- Water pump installation
- Water pump seal (for leakage)
- Deformed radiator filler neck

COOLANT

⚠ WARNING

- **Radiator coolant is toxic. Keep it away from eyes, mouth, skin and clothes.**
 - If any coolant gets in your eyes, rinse them with water and consult a doctor immediately.
 - If any coolant is swallowed, induce vomiting, gargle and consult a physician immediately.
 - If any coolant gets on your skin or clothes, rinse thoroughly with plenty of water.
- **KEEP OUT OF REACH OF CHILDREN**

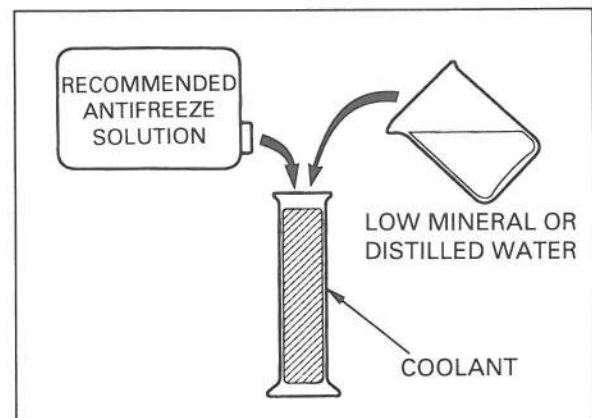

CAUTION:

Using coolant with silicate inhibitors may cause premature wear of water pump seals or blockage of radiator passages. Using tap water may cause engine damage.

NOTE:

- The effectiveness of coolant decreases with the accumulation of rust or if there is a change in the mixing proportion during usage. Therefore, for best performance change the coolant regularly as specified in the maintenance schedule.
- Mix only distilled, low mineral water with the antifreeze.

RECOMMENDED ANTIFREEZE :

Pro Honda HP Coolant or an equivalent high quality ethylene glycol antifreeze containing corrosion protection inhibitors

RECOMMENDED MIXTURE:

50 – 50 (Distilled water and recommended anti freeze)

REPLACEMENT/AIR BLEEDING

⚠ WARNING

The engine must be cool before removing the radiator cap, or severe scalding may result.

NOTE:

When filling the system or reserve tank with a coolant (checking the coolant level), place the motorcycle in a vertical position on a flat, level surface.

- Remove the fuel tank (page 2-4).
- Remove the steering covers (page 2-3).
- Remove the radiator cap.

Drain the coolant from the system by removing the drain bolt and sealing washer on the water pump cover.

Remove the rear cylinder coolant drain bolt and drain the coolant.

Reinstall the drain bolts with a new sealing washer. Tighten the bolts to the specified torque.

TORQUE: 13 N·m (1.3 kgf·m, 9 lbf·ft)

Remove the reserve tank (page 6-18).

Remove the reserve tank cap from the reserve tank and drain the reserve coolant.

Empty the coolant and rinse the inside of the reserve tank with water.

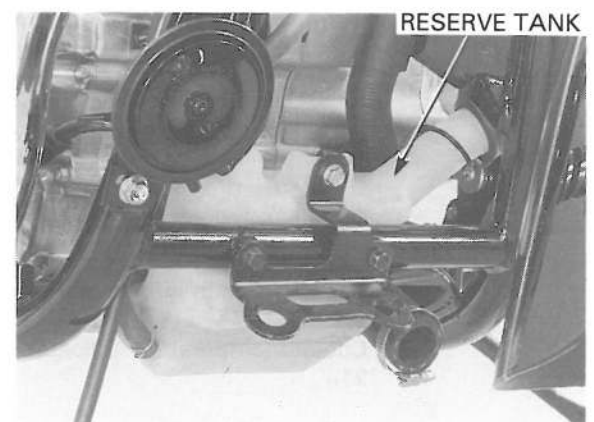
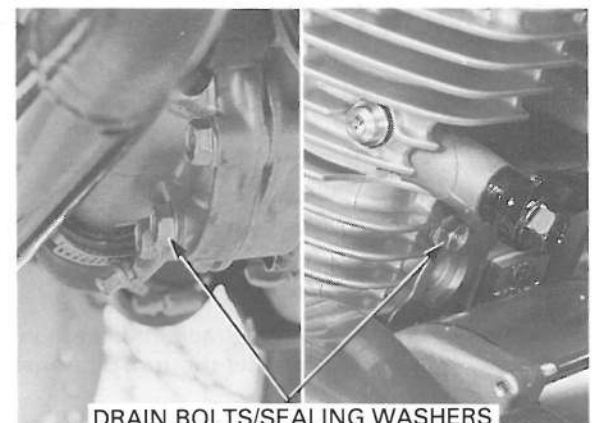
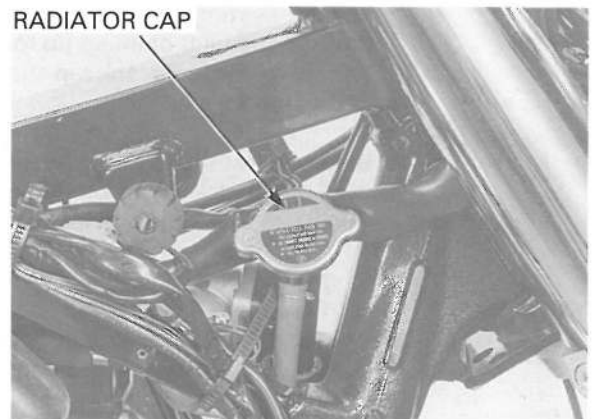

COOLING SYSTEM

Install the reserve tank (page 6-18).

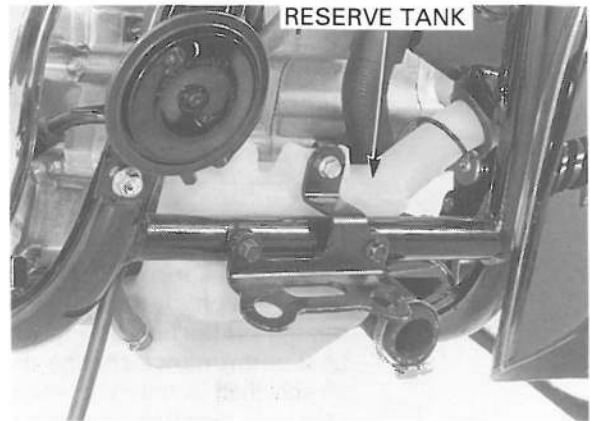

Fill the system with the recommended coolant through the filler opening up to filler neck. Remove the reserve tank cap and fill the reserve tank to the upper level line.

Bleed air from the system as follows:

1. Shift the transmission into neutral.
Start the engine and let it idle for 2 - 3 minutes.
2. Snap the throttle 3 - 4 times to bleed air from the system.
3. Stop the engine and add coolant up to the filler neck. Reinstall the radiator cap.
4. Check the level of coolant in the reserve tank and fill to the upper level if it is low.

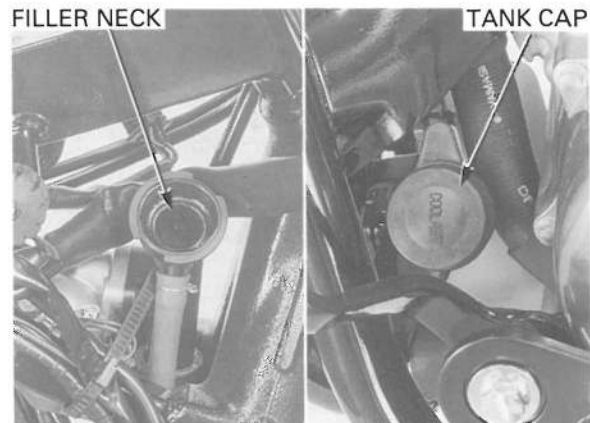

THERMOSTAT

REMOVAL

Remove the following:

- Fuel tank (page 2-4)
- Steering covers (page 2-3)

Drain the coolant (page 6-5).

Remove the radiator filler mounting bolts. Remove the thermostat housing cover bolts and cover.

Remove the O-ring and thermostat from the housing.

NOTE:

The thermo switch, may be damaged if dropped or shocked. If dropped or shocked, inspect the thermo switch and replace if necessary (page 19-21).

Thermo switch inspection and removal (page 19-22).
Coolant temperature indicator inspection (page 19-21).

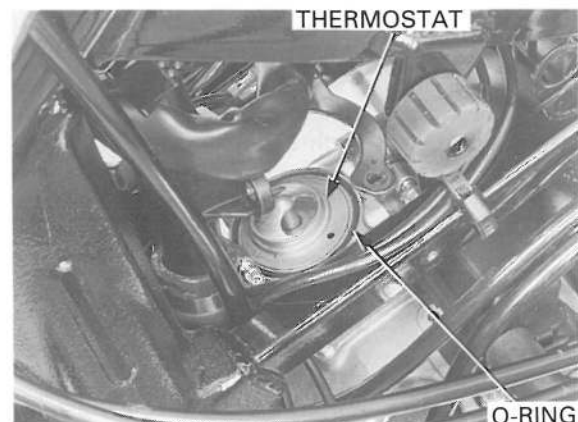
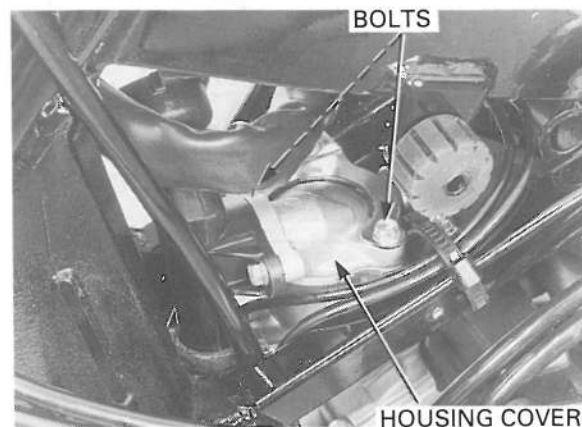

INSPECTION

⚠ WARNING

- *Wear insulated gloves and adequate eye protection.*
- *Keep flammable materials away from the electric heating element.*

NOTE:

- Do not let the thermostat or thermometer touch the pan, or you will get false readings.
- Replace the thermostat if valve stays open at room temperature, or if it responds at temperatures other than those specified.

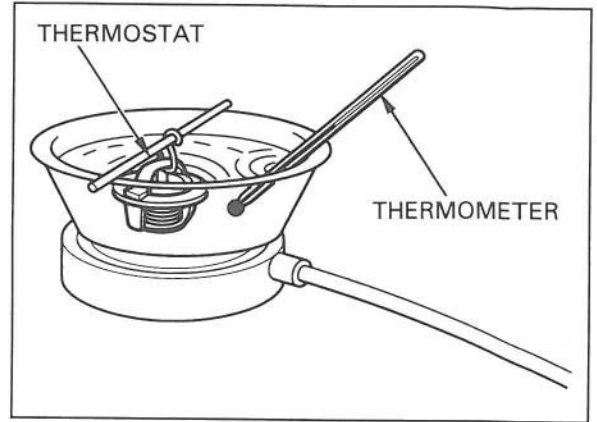

Visually inspect the thermostat for damage.

Heat the water with an electric heating element to operating temperature for 5 minutes. Suspend the thermostat in heated water to check its operation.

THERMOSTAT BEGINS TO OPEN:

80 – 84°C (176 – 183°F)

VALVE LIFT:

8 mm (0.3 in) minimum at 95°C (203°F)

INSTALLATION

Install the thermostat while aligning it with the groove in the housing.

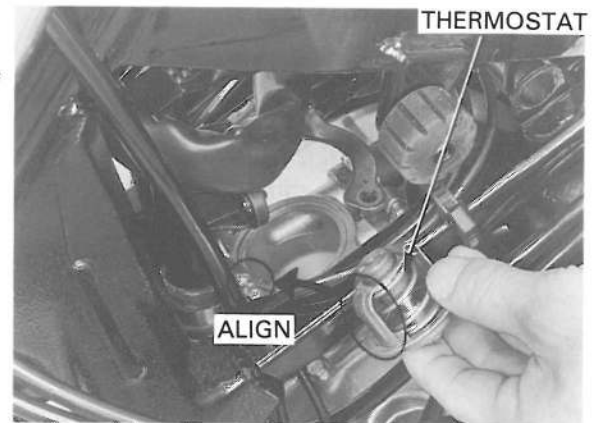

Install the new O-ring into the housing.



COOLING SYSTEM

Install the thermostat housing cover.
Install and tighten the housing cover bolts to the specified torque.

TORQUE: 9 N·m (0.9 kgf·m, 6.5 lbf·ft)

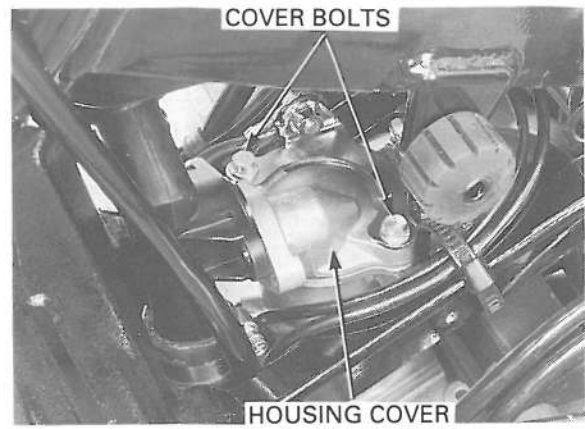

Install the new O-ring to the radiator filler.



Install and tighten the radiator filler mounting bolts to the specified torque.

TORQUE: 9 N·m (0.9 kgf·m, 6.5 lbf·ft)

Install the following:

- Steering covers (page 2-3)
- Fuel tank (page 2-4)

Fill and bleed the cooling system (page 6-6).

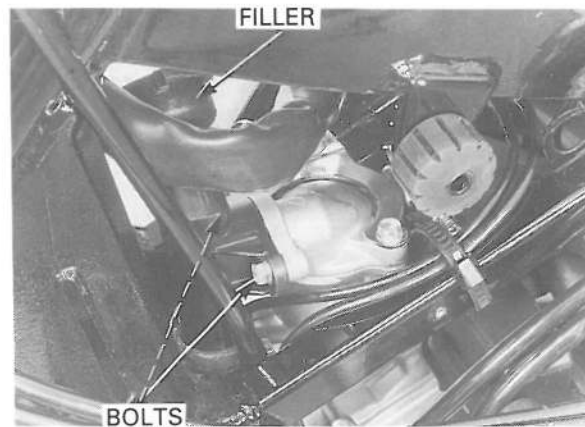

RADIATOR/COOLING FAN

CAUTION:

Be careful not to damage the radiator fins.

REMOVAL

Drain the coolant (page 6-5).
Remove the fuel tank (page 2-4).
Remove the steering covers (page 2-3).

Disconnect the fan motor 2P (Black) connector.

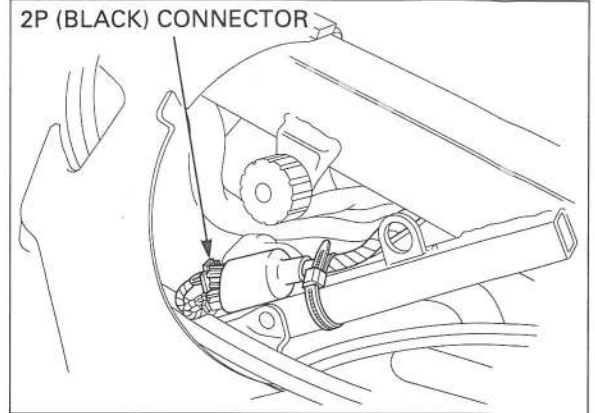

Loosen the hose band and disconnect the lower radiator hose from the radiator.

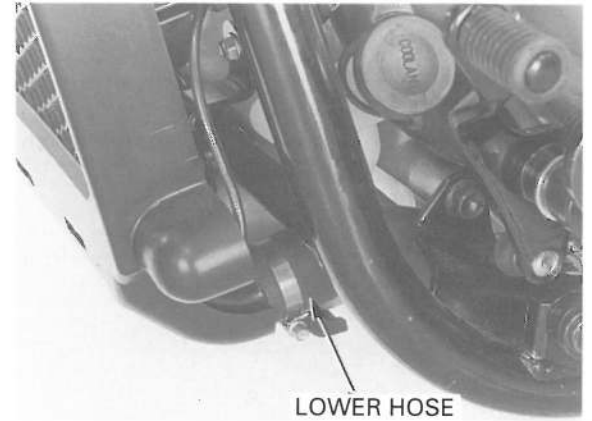

Remove the radiator mounting bolt and washer then pull out the radiator.



Loosen the hose band and disconnect the upper radiator hose from the radiator.

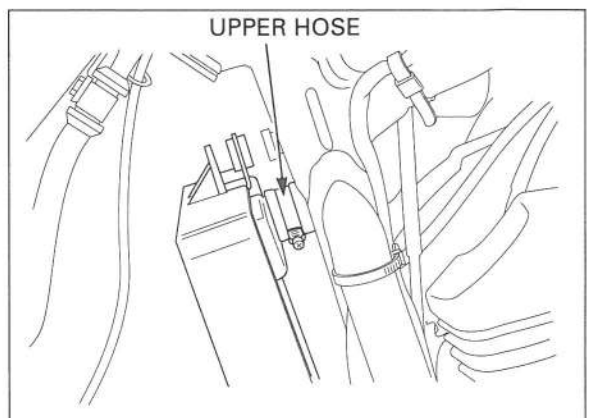

COOLING SYSTEM

Unhook the radiator mount rubbers from the frame stays and remove the radiator.

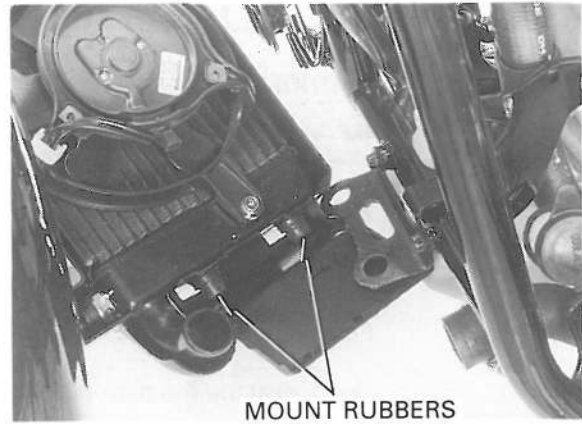

DISASSEMBLY

Remove the radiator mount rubbers from the radiator.
Remove the radiator grille from the radiator.

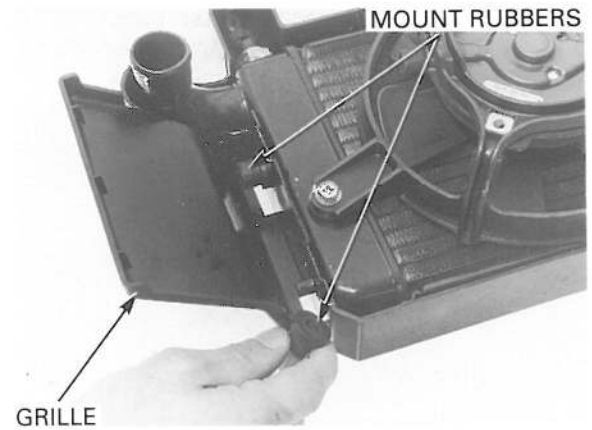

Disconnect the fan motor switch connector.
Remove the wires from the clamp.

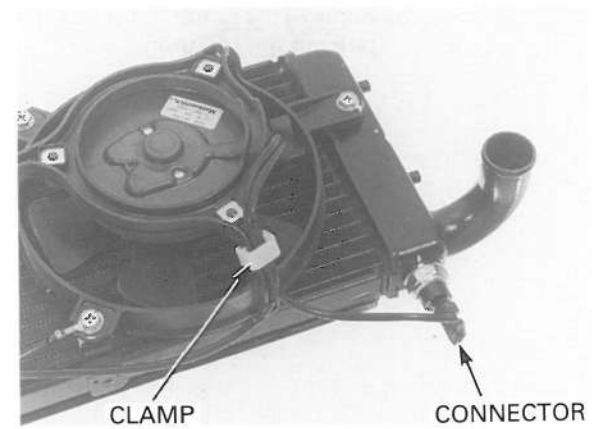

Remove the bolts and ground terminal.
Remove the cooling fan assembly from the radiator.

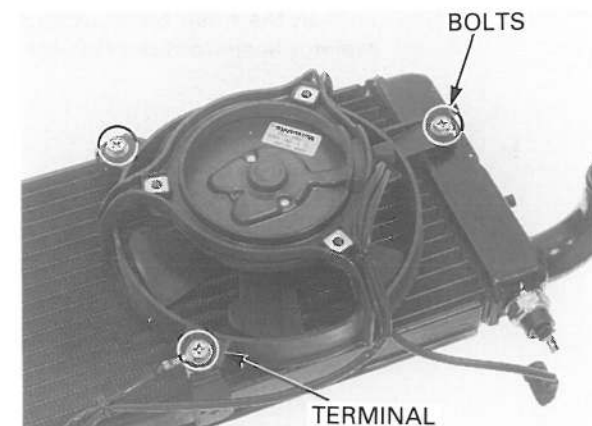

Remove the nut and cooling fan.

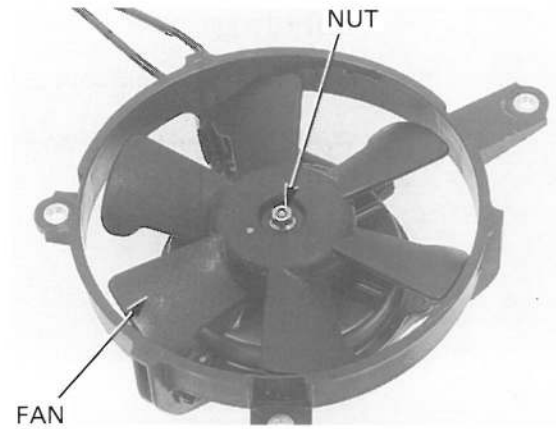

Remove the bolts and fan motor from the shroud.

The fan motor switch removal and inspection procedure is described on page 19-19.

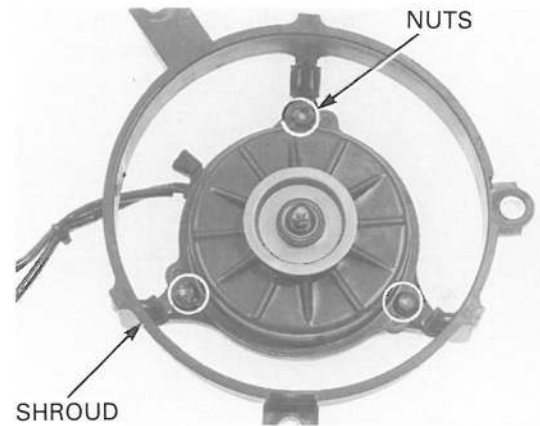

ASSEMBLY

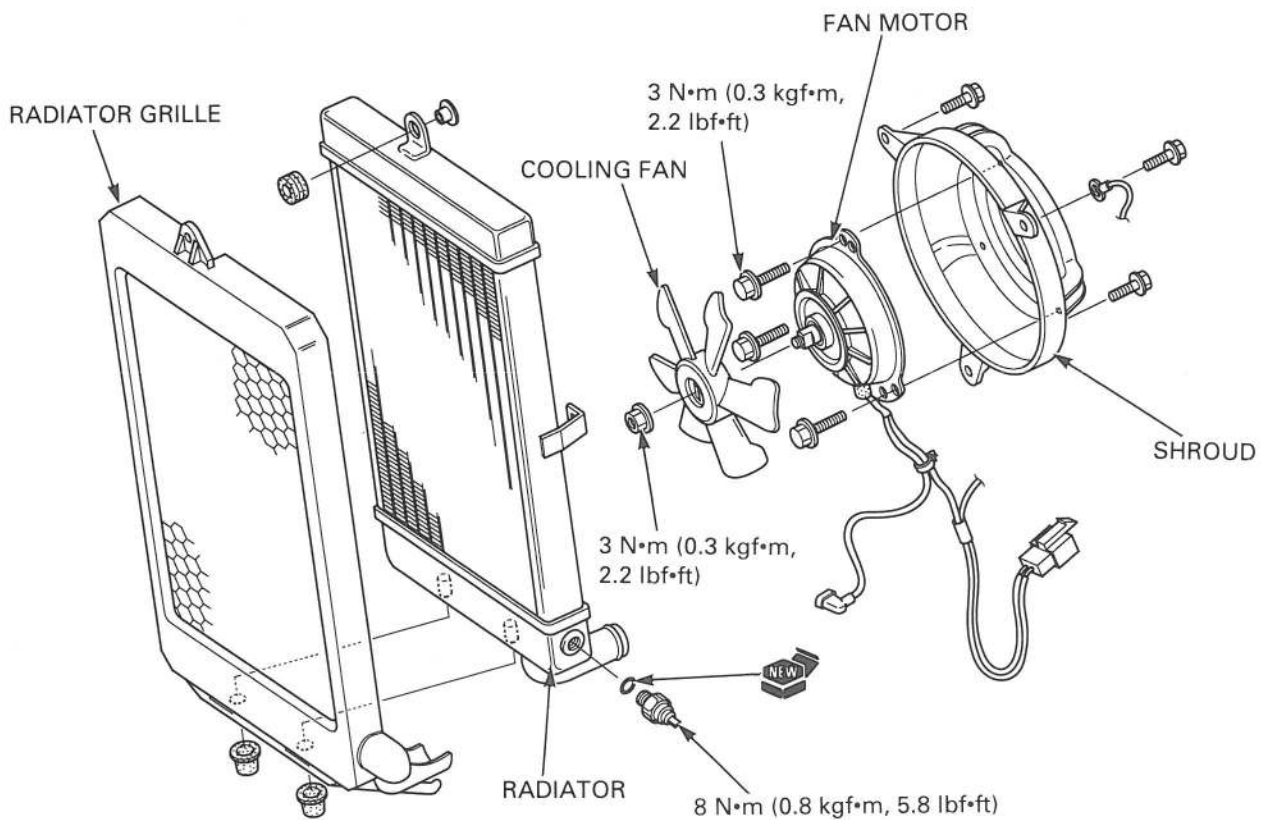

COOLING SYSTEM

Install the fan motor to the shroud.

Install and tighten the bolts to the specified torque.

TORQUE: 3 N·m (0.3 kgf·m, 2.2 lbf·ft)

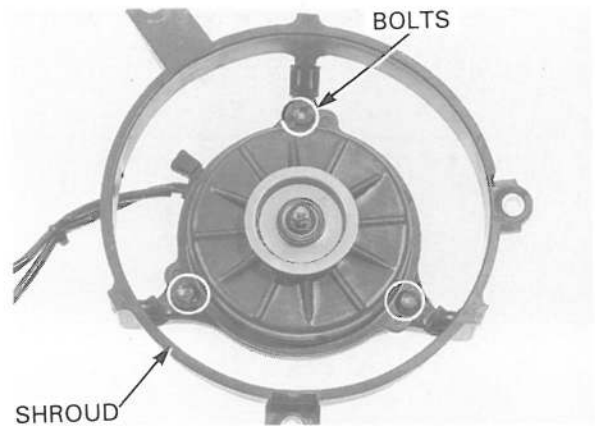

Install the cooling fan onto the motor shaft by aligning the flat surfaces.

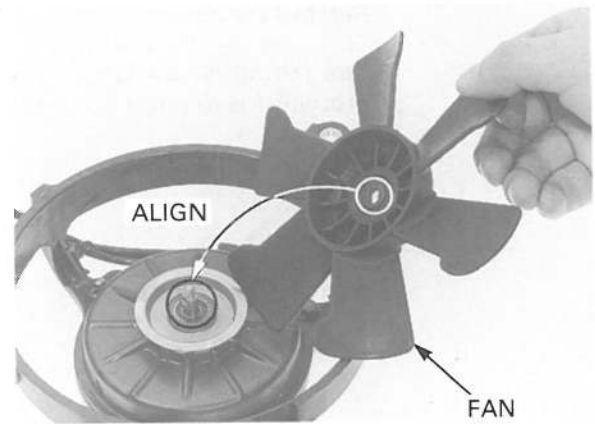

Install and tighten the nut to the specified torque.

TORQUE: 3 N·m (0.3 kgf·m, 2.2 lbf·ft)

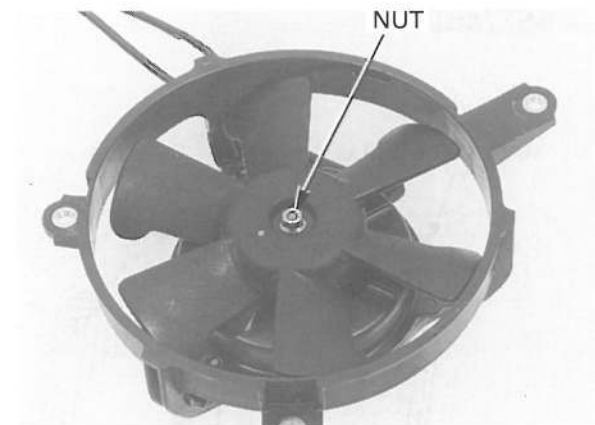

Install the cooling fan assembly to the radiator.
Install and tighten the bolts with the ground terminal.

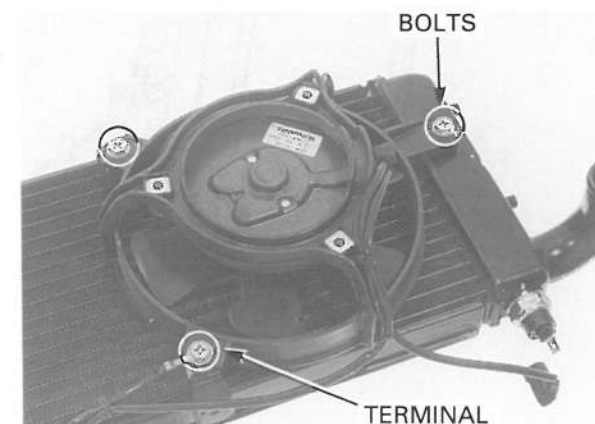

Connect the fan motor switch connector.

Route the ground wire and fan motor switch wire properly, clamp the wires.

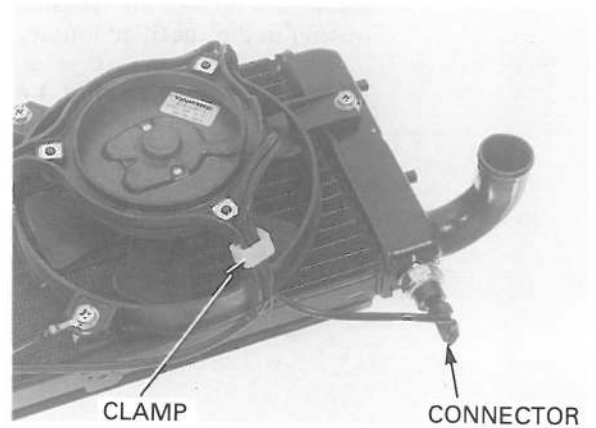

Install the radiator grille to the radiator by aligning its holes with the bosses on the radiator. Install the radiator mounting rubbers to the radiator bosses.

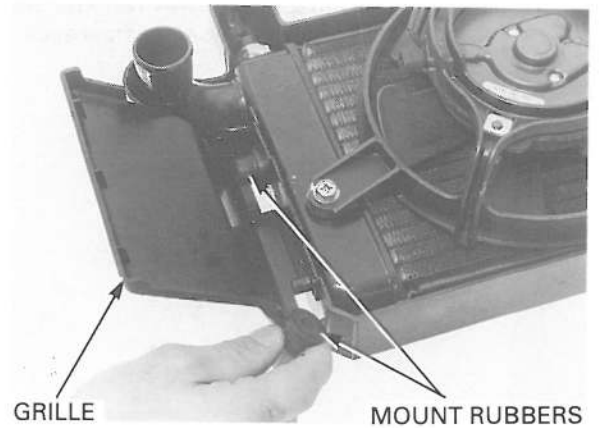

INSTALLATION

Hook the radiator mount rubbers to the frame stay.

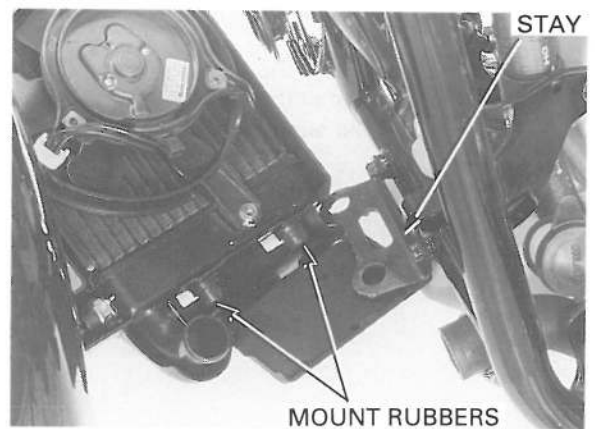

Connect the upper radiator hose and tighten the radiator hose band screw securely.

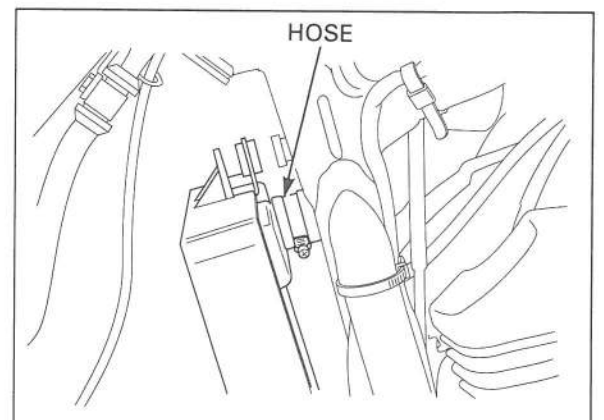

COOLING SYSTEM

Install and tighten the radiator mounting bolt and washer to the specified torque.

TORQUE: 2 N·m (0.2 kgf·m, 1.4 lbf·ft)



Connect the lower radiator hose and tighten the radiator hose band screw securely.

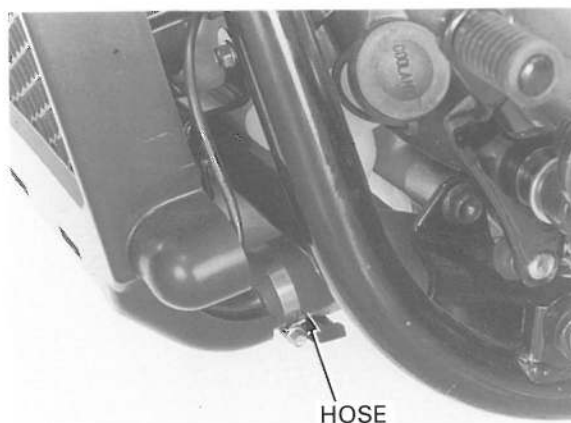

Connect the fan motor 2P (Black) connector.

Install the steering covers (page 2-3).

Install the fuel tank (page 2-4).

Fill and bleed the cooling system (page 6-6).

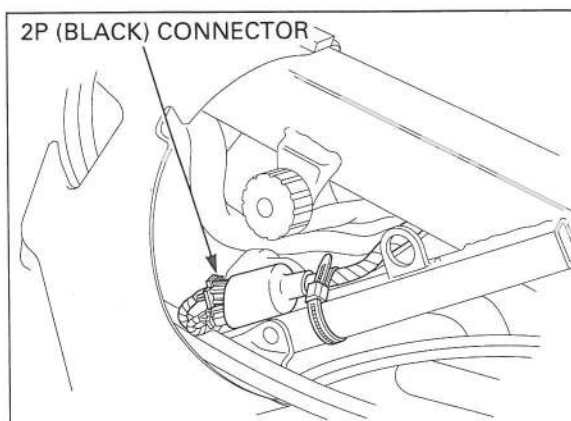

WATER PUMP

MECHANICAL SEAL INSPECTION

The water pump cover and O-ring can be removed with engine in the frame.

Inspect the telltale hole for signs of coolant leakage. If there is leakage, the mechanical seal is defective and the water pump assembly must be replaced.

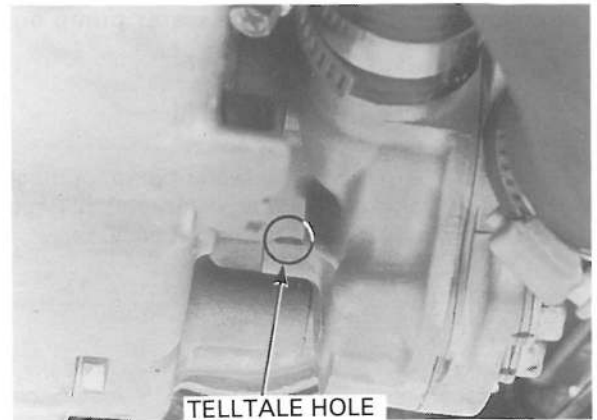

REMOVAL

Remove the engine from the frame (Section 7).

Loosen the band screw and remove the water hose from the water pump cover.

Remove the water pump cover mounting bolts.

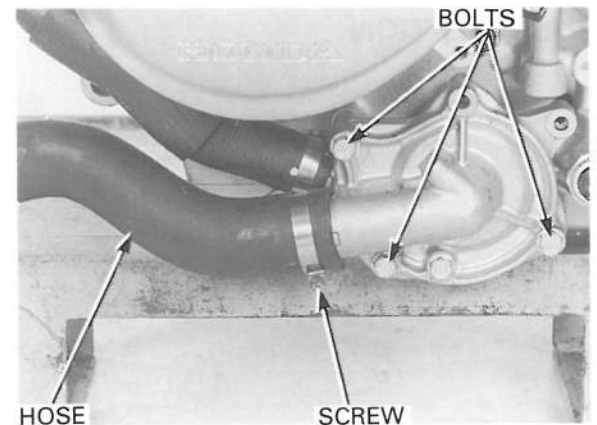

Remove the water pump cover and O-ring from the water pump.

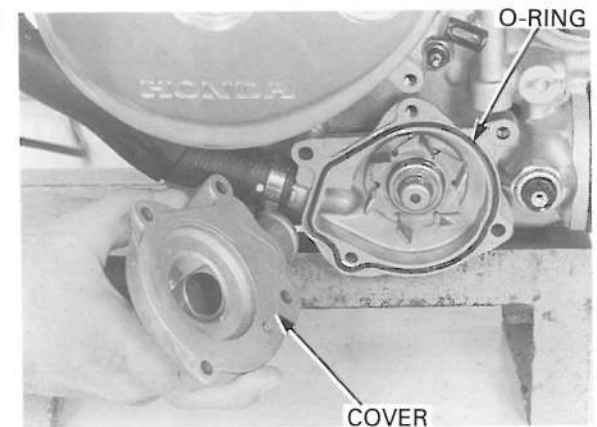

Loosen the band screw and remove the water hose from the water pump.

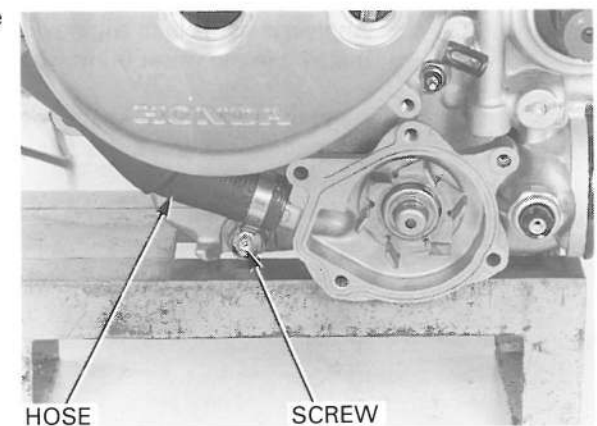

COOLING SYSTEM

Do not disassemble the water pump. Replace the pump as an assembly if it is damaged.

Remove the water pump and O-ring from the crankcase.

INSPECTION

Check the water pump for mechanical seal leakage and bearing deterioration. Replace the water pump as an assembly if necessary.

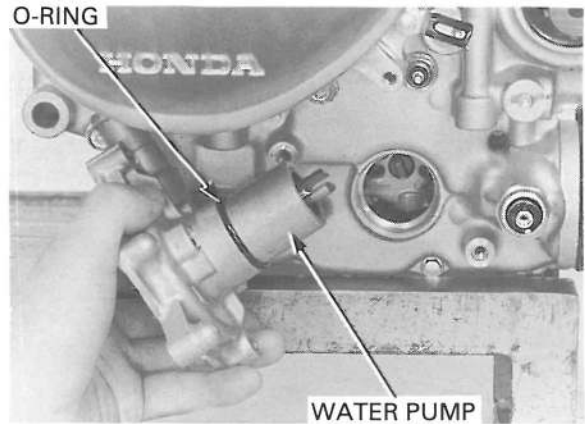

INSTALLATION

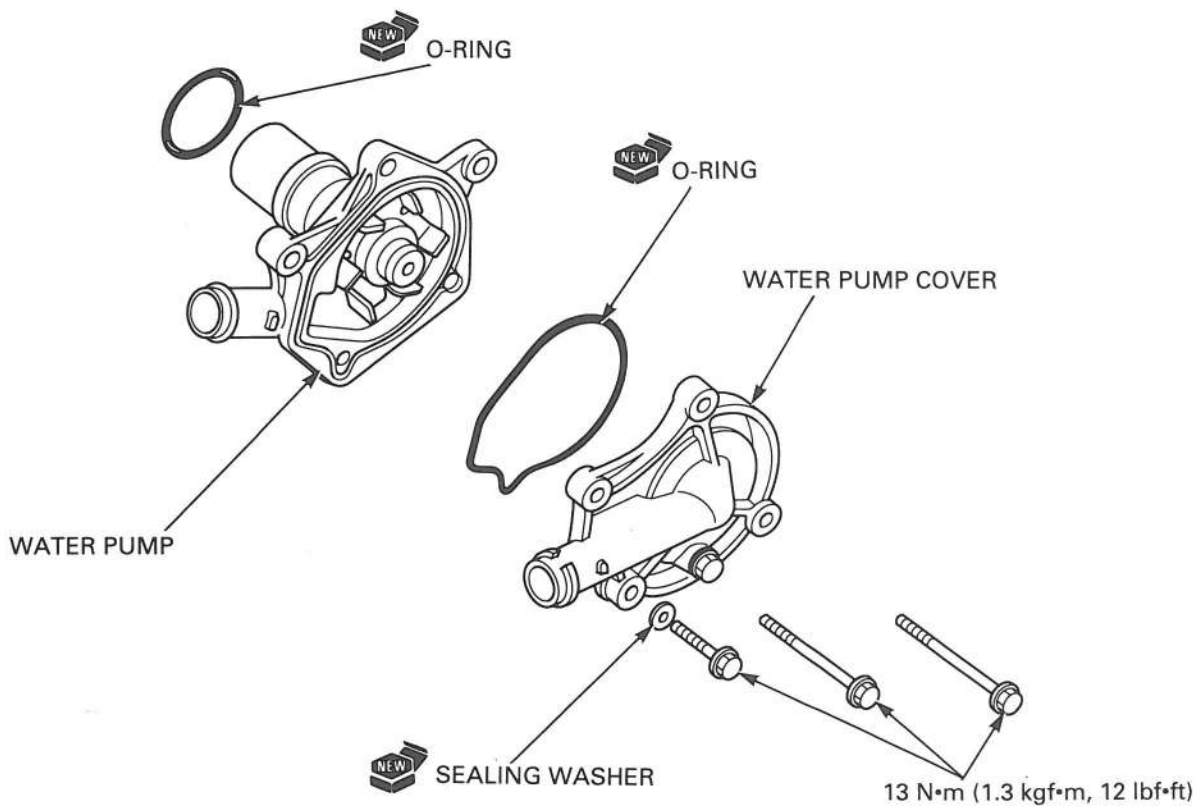

Apply a coat of clean engine oil to a new O-ring and install it in the water pump shaft housing groove.

Align the water pump shaft groove with the oil pump shaft and insert the water pump into the crankcase.

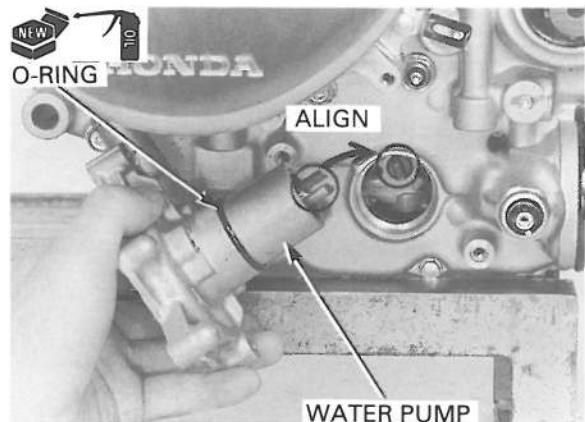

Connect the water hose to the water pump by aligning the white paint on the hose with the boss on the water pipe then tighten the hose band securely.

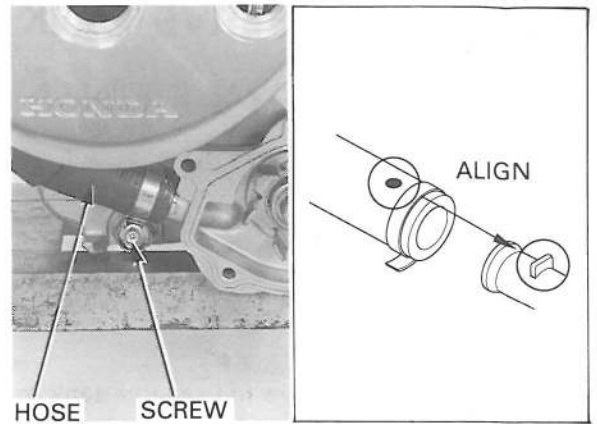

Apply a coat of clean engine oil to a new O-ring and install it around the impeller housing.

Install the water pump cover to the water pump.

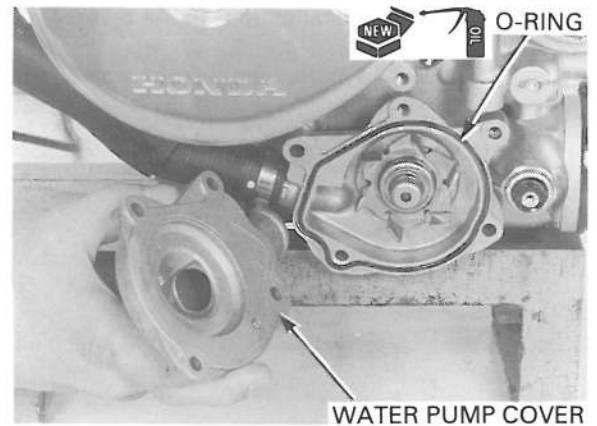

Install the bolts and sealing washer as shown. Tighten the cover bolts to the specified torque.

TORQUE: 13 N·m (1.3 kgf·m, 9 lbf·ft)

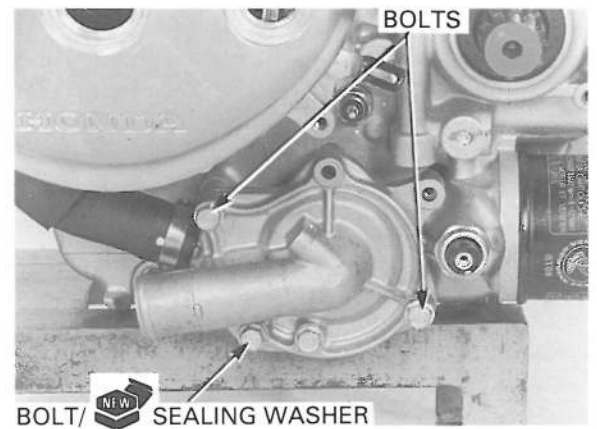

Connect the water hose to the water pump cover then tighten the hose band securely.

Install the engine in the frame (Section 7).

Fill and bleed the cooling system (page 6-6).
Fill the engine with the recommended engine oil (page 3-12).

Check the cooling system for leakage.

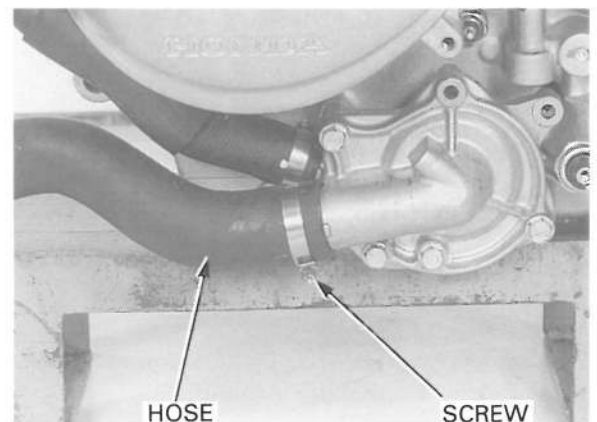

RADIATOR RESERVE TANK

REMOVAL/INSTALLATION

Remove the radiator (page 6-9).

Place a suitable container under the siphon tube joint of the reserve tank.

Disconnect the radiator siphon tube at the reserve tank.

Remove the reserve tank mounting bolt, filler mounting nut and reserve tank.

Installation is in the reverse order of removal.

Fill the reserve tank with coolant (page 6-4).

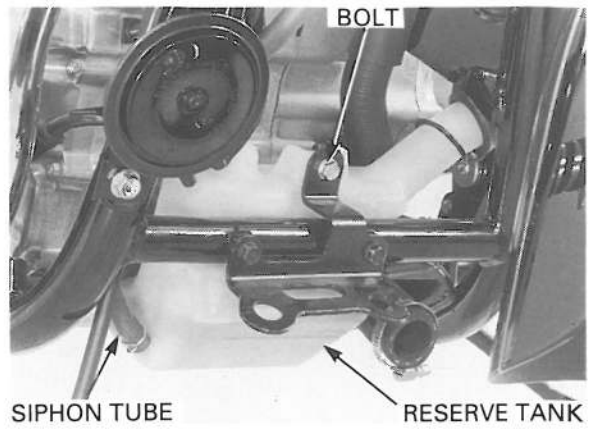

MEMO

ENGINE REMOVAL/INSTALLATION

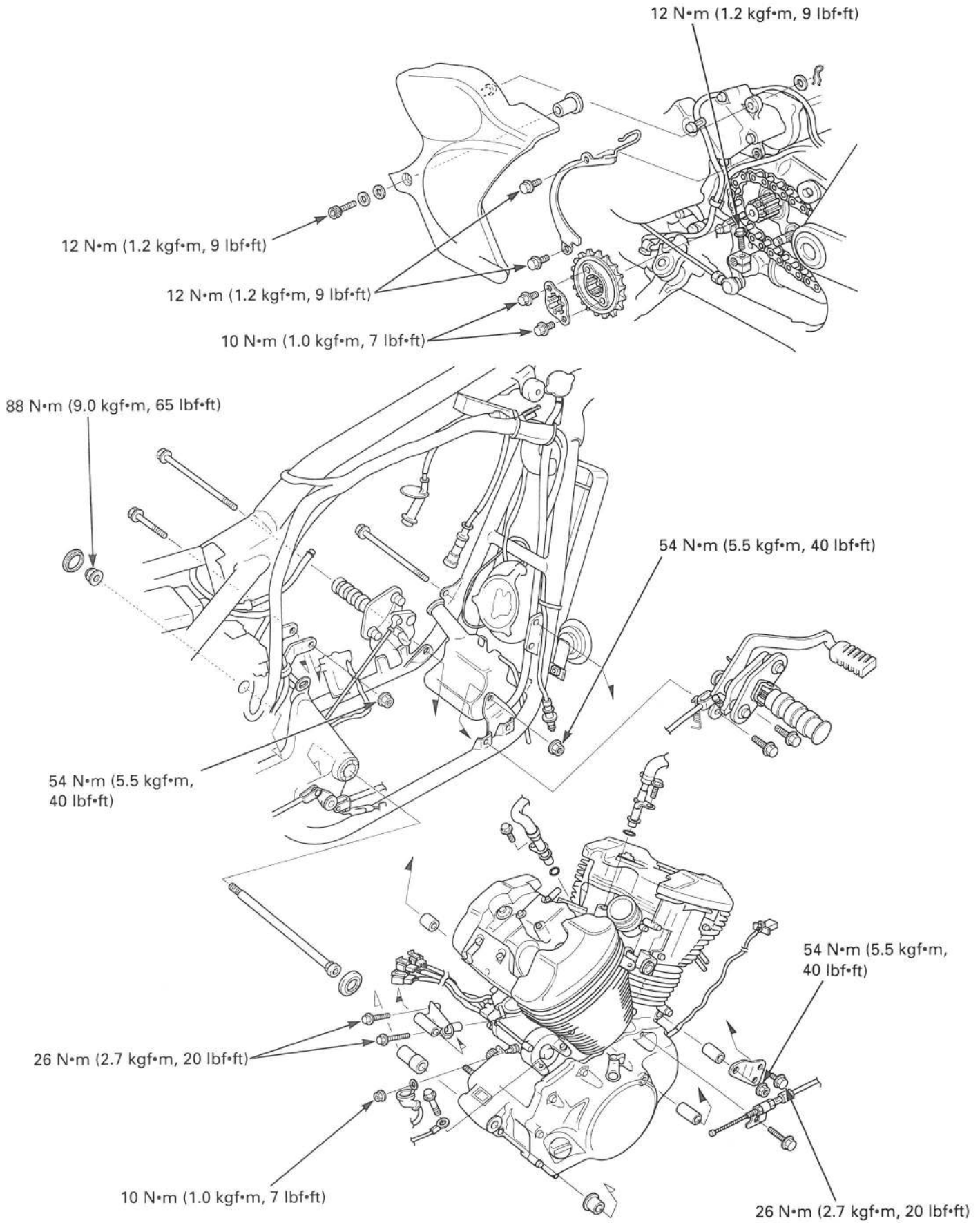

7. ENGINE REMOVAL/INSTALLATION

SERVICE INFORMATION	7-2	ENGINE INSTALLATION	7-9
DRIVE SPROCKET REMOVAL	7-3	DRIVE SPROCKET INSTALLATION	7-13
ENGINE REMOVAL	7-5		

SERVICE INFORMATION

GENERAL

- A floor jack or other adjustable support is required to support and maneuver the engine.

CAUTION:

Do not support the engine using the oil filter.

- When removing/installing the engine, tape the frame around the engine beforehand for fame protection.
- The following components can be serviced with the engine installed in the frame.
 - Alternator (Section 9)
 - Camshaft (Section 10)
 - Carburetor (Section 5)
 - Clutch/gearshift linkage (Section 8)
 - Front cylinder (Section 11)
 - Front cylinder head (Section 10)
 - Ignition pulse generator (Section 17)
 - Starter motor/starter clutch (Section 18)
- The following components require engine removal for service.
 - Cylinder/piston (Section 11)
 - Crankshaft (Section 12)
 - Oil pump (Section 4)
 - Rear cylinder (Section 11)
 - Rear cylinder head (Section 10)
 - Shift fork, shift drum and shift spindle (Section 12)
 - Transmission (Section 12)
 - Water pump body (Section 6)
- After engine installation, adjust the following.
 - Clutch cable (page 3-26)
 - Drive chain (page 3-18)
 - Throttle cable (page 3-4)

ENGINE REMOVAL/INSTALLATION

SPECIFICATIONS

ITEM	SPECIFICATIONS
Engine dry weight	68.6 kg (151 lbs)
Engine oil capacity at disassembly	2.9 liter (3.06 US qt, 2.55 Imp qt)
Coolant capacity	1.75 liter (1.85 US qt, 1.54 Imp qt)

TORQUE VALUES

Left rear cover bolt	12 N•m (1.2 kgf•m, 9 lbf•ft)
Drive sprocket bolt	10 N•m (1.0 kgf•m, 7 lbf•ft)
Drive chain guide plate bolt	12 N•m (1.2 kgf•m, 9 lbf•ft)
Oil pressure switch cord terminal screw	2 N•m (0.2 kgf•m, 1.4 lbf•ft)
Front engine mounting bolt	54 N•m (5.5 kgf•m, 40 lbf•ft)
Rear engine mounting bolt	54 N•m (5.5 kgf•m, 40 lbf•ft)
Front engine bracket bolt	26 N•m (2.7 kgf•m, 20 lbf•ft)
Rear engine bracket bolt	26 N•m (2.7 kgf•m, 20 lbf•ft)
Gearshift arm pinch bolt	12 N•m (1.2 kgf•m, 9 lbf•ft)
Swingarm pivot bolt	88 N•m (9.0 kgf•m, 65 lbf•ft)

DRIVE SPROCKET REMOVAL

Loosen the rear axle nut.
Turn both adjusting bolts as necessary.
Push the rear wheel forward fully, making the a drive chain fully slack .

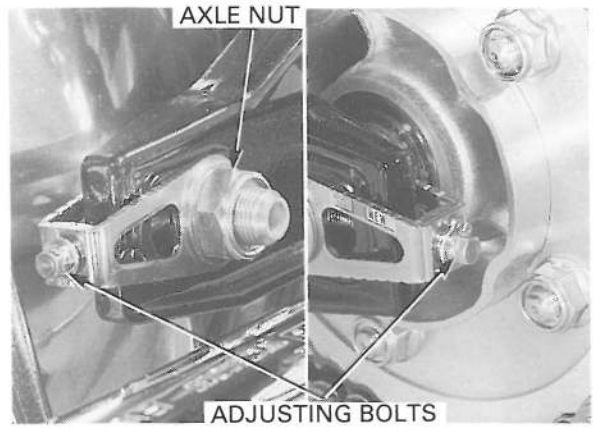

Turn the clip inside the top of the drive sprocket cover up and remove clip and washer.

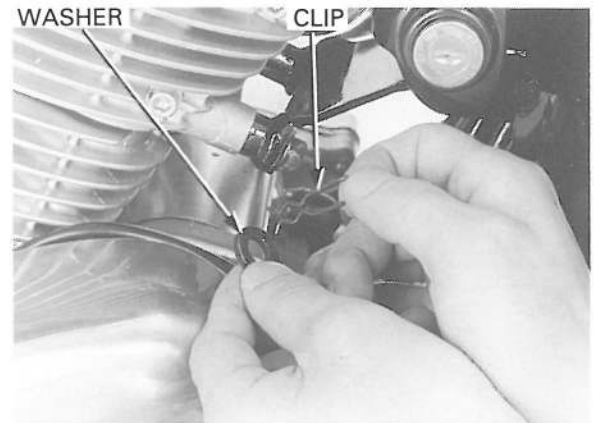

Remove the bolt, washer, rubber, left rear cover and collar.

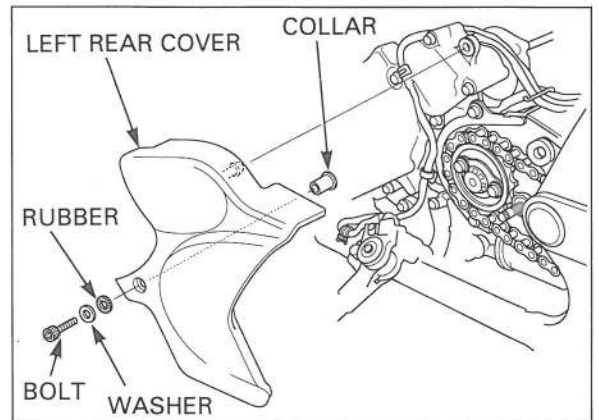

Remove the bolt and gearshift arm.

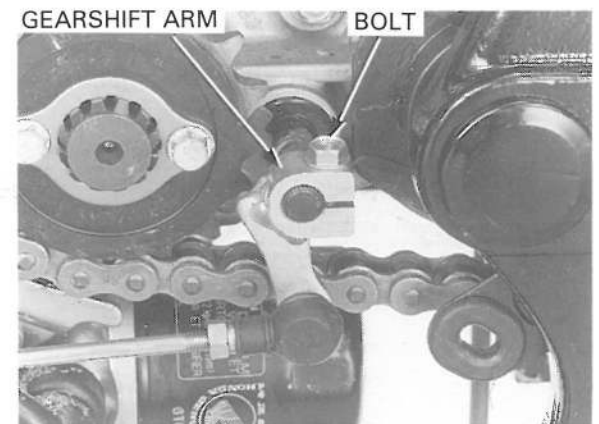

ENGINE REMOVAL/INSTALLATION

Remove the drive sprocket setting plate bolts.

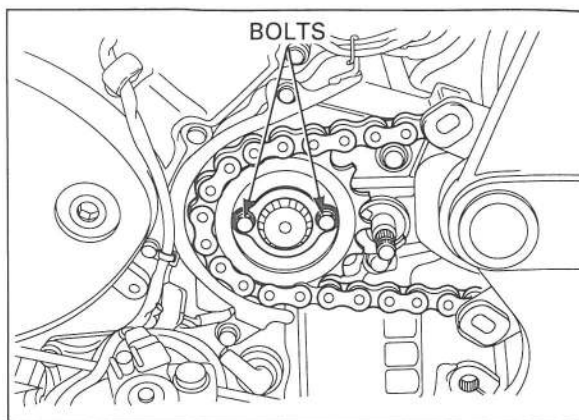

Align the drive sprocket setting plate tooth and countershaft tooth, then remove the drive sprocket setting plate.

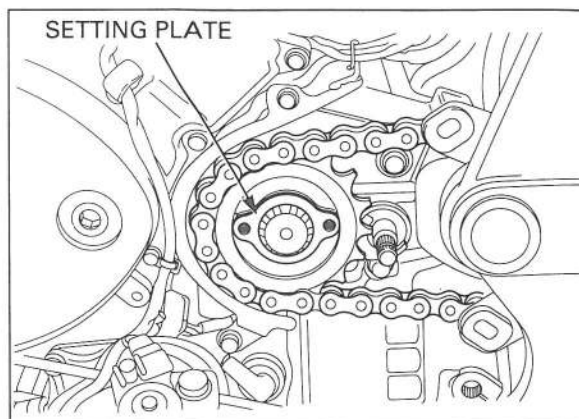

Remove the drive sprocket.

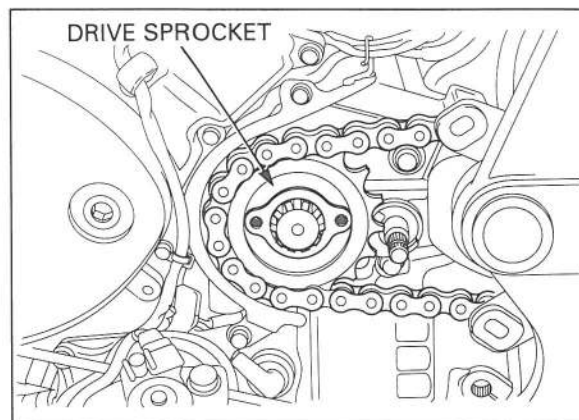

ENGINE REMOVAL

CAUTION:

Do not support the engine using the oil filter.

NOTE:

- Support the motorcycle safety stand or a hoist.
- A floor jack or adjustable support is required to support and maneuver the engine. The jack height must be continually adjusted to relieve stress for ease of bolt removal.

Drain the engine oil (page 3-12) and radiator coolant (page 6-5).



ENGINE REMOVAL/INSTALLATION

Disconnect the battery negative cable from the battery terminal.

Remove the following:

- Fuel tank (page 2-4)
- Steering cover (page 2-3)
- Air cleaner housing (page 5-4)
- Air cleaner chamber (page 5-6)
- Carburetor (page 5-8)
- Sub-air cleaner housing (page 10-5)
- Cylinder head cover outer cover (page 10-5)
- Exhaust pipe/muffler (page 2-7)
- Right footpeg and rear brake pedal (page 14-15)
- Drive sprocket (page 7-3)

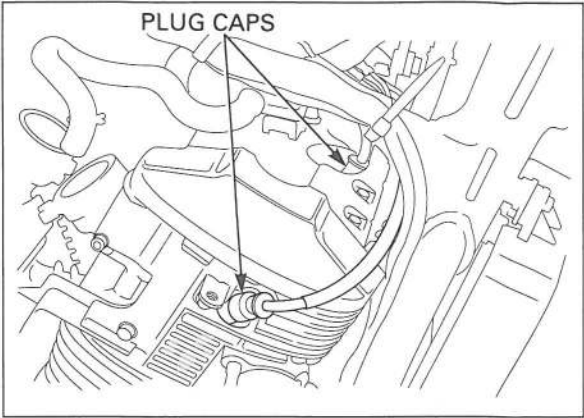

Disconnect the spark plug caps.

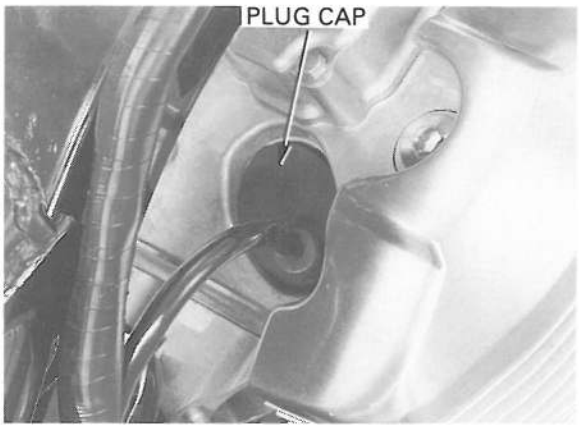

Remove the screw and disconnect the oil pressure switch cord terminal from the switch. Disconnect the neutral switch cord from the switch terminals. Free the side stand switch wire from the clamps.

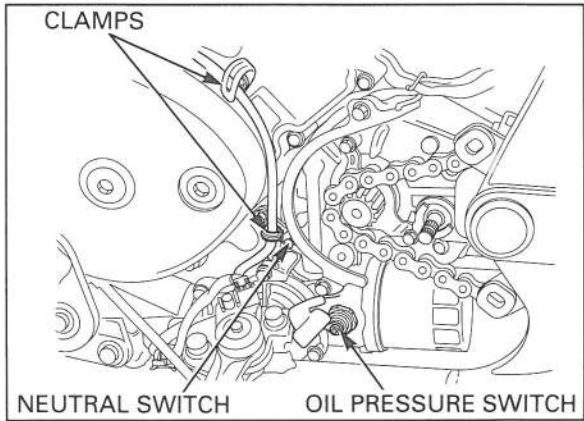

Remove the bolts and clamp, drive chain guide plate and countershaft bearing set plate. Free the oil pressure and neutral switch wires.

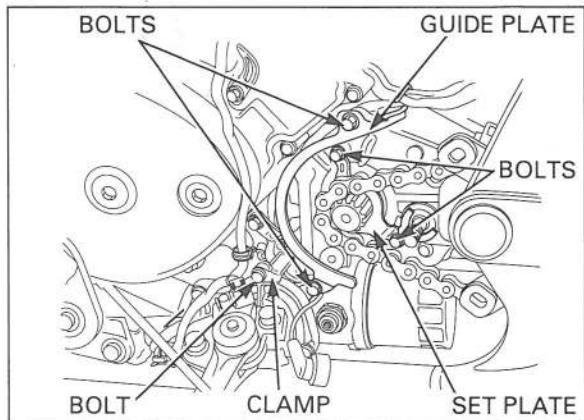

ENGINE REMOVAL/INSTALLATION

Remove the nuts then disconnect the starter motor cable and ground cable from the starter motor.

STARTER MOTOR CABLE

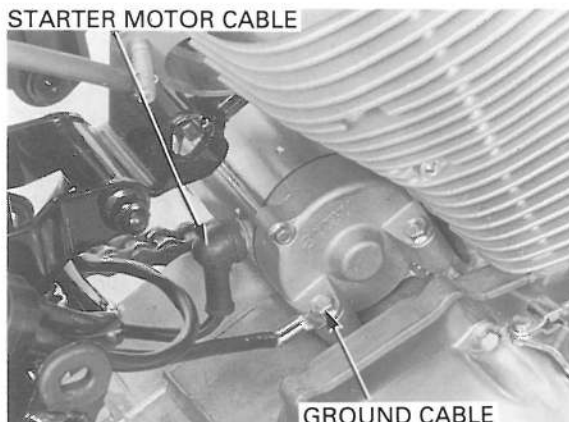

Remove the clutch cable holder bolt and disconnect the clutch cable from the clutch lifter arm.

CLUTCH CABLE HOLDER

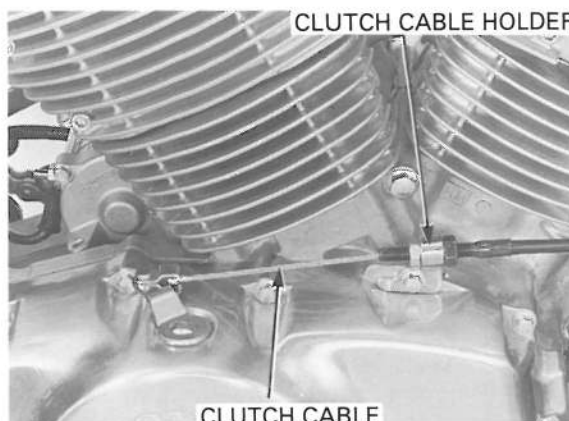

Disconnect the ignition pulse generator wire 2P (White) connector and free the wire harness from the engine and frame.

IGNITION PULSE GENERATOR CONNECTOR

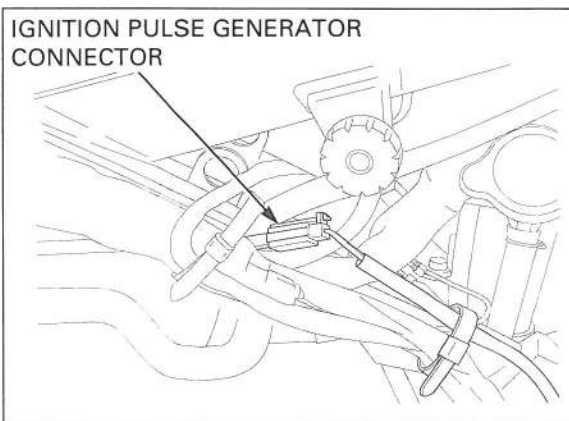

Disconnect the alternator wire 3P connector (White) and free the wire harness from the engine and frame.



Loosen the hose band and disconnect the lower radiator hose from the radiator.

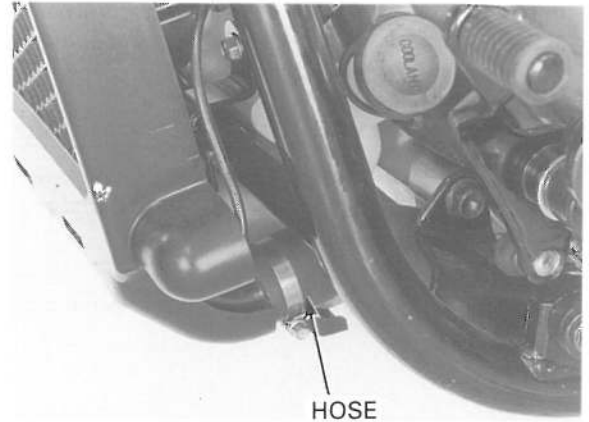

Remove the bolts and disconnect the water pipes (thermostat housing-to-cylinder heads) from the cylinder heads.

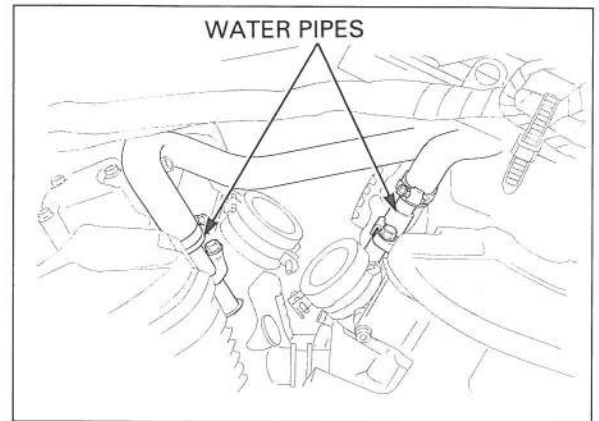

The jack height must be continually adjusted to relieve stress for bolt removal.

Place a floor jack or other adjustable support under the engine.

CAUTION:

Do not support the engine using the oil filter. This may break the oil filter mount resulting in crankcase replacement.

Remove the front upper engine mounting bolt/nut (10 mm) and collar.

Remove the front upper engine bracket bolts (8 mm) and bracket.

Remove the front lower engine mounting bolt/nut (10 mm).

Remove the front lower engine bracket bolts (8 mm) and bracket.

Remove the rear engine mounting bolt/nut (10 mm).
Remove the rear engine bracket bolts (8 mm) and bracket.

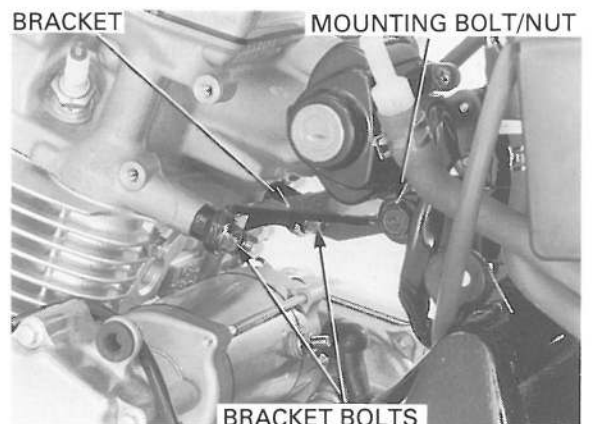
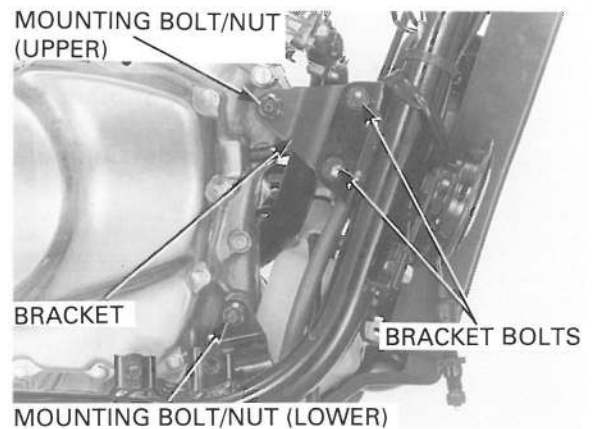

ENGINE REMOVAL/INSTALLATION

Remove the swingarm pivot bolt caps.
Remove the swingarm pivot nut, lock nut, pivot bolt and collars.

CAUTION:

During engine removal, hold the engine securely and be careful not to damage the frame, engine and radiator fin.

Remove the engine from the right side of the frame.

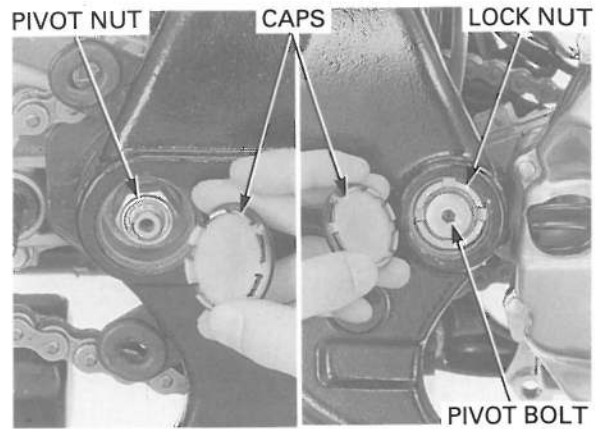

ENGINE INSTALLATION

CAUTION:

Carefully align the mounting points with the jack to prevent damage to engine, frame, wires and cables.

NOTE:

- All the engine mounting bolts and nuts loosely install, then tighten the bolts and nuts to the specified torque.
- At engine installation, temporarily install the drive chain to the gearshift spindle.
- Be sure to install the mounting collars and swingarm dust seals in their correct positions.

Use a floor jack or other adjustable support to carefully maneuver the engine in to place.
Carefully align the bolt holes in the frame and engine.

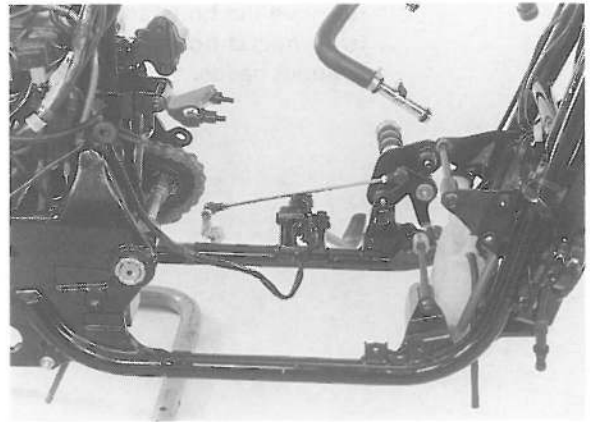

Install the swingarm pivot collars, pivot bolt and nut.
Tighten the swingarm pivot bolt and nuts to the specified torque.
– Tightening procedure (page 14-26).

Install the swingarm pivot bolt caps.

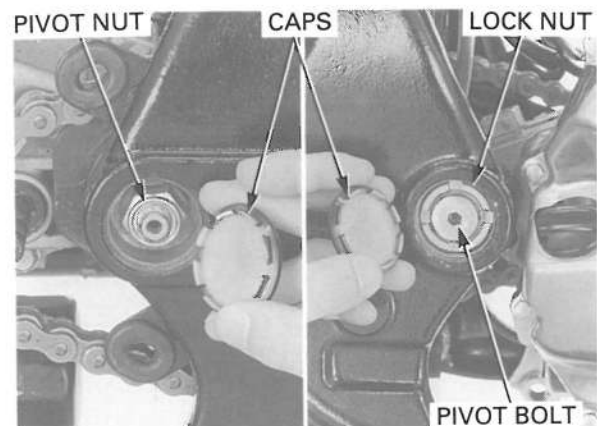

ENGINE REMOVAL/INSTALLATION

Install the rear engine bracket and bracket bolts (8 mm).

Install the rear engine mounting bolt/nut (10 mm).

Install the front lower engine bracket and bracket bolts (8 mm).

Install the front lower engine mounting bolt/nut (10 mm).

Install the front upper engine bracket and bracket bolts (8 mm).

Install the collar and front upper engine mounting bolt/nut (10 mm).

Tighten the engine bracket and mounting bolt/nut to the specified torque.

TORQUE:

Front engine mounting bolt
54 N·m (5.5 kgf·m, 40 lbf·ft)

Rear engine mounting bolt
54 N·m (5.5 kgf·m, 40 lbf·ft)

Front engine bracket bolt
26 N·m (2.7 kgf·m, 20 lbf·ft)

Rear engine bracket bolt
26 N·m (2.7 kgf·m, 20 lbf·ft)

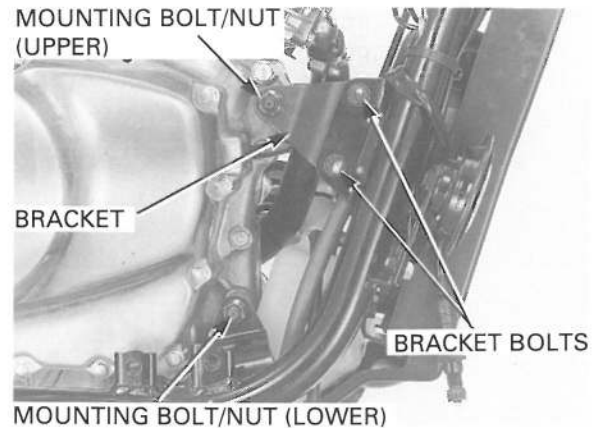
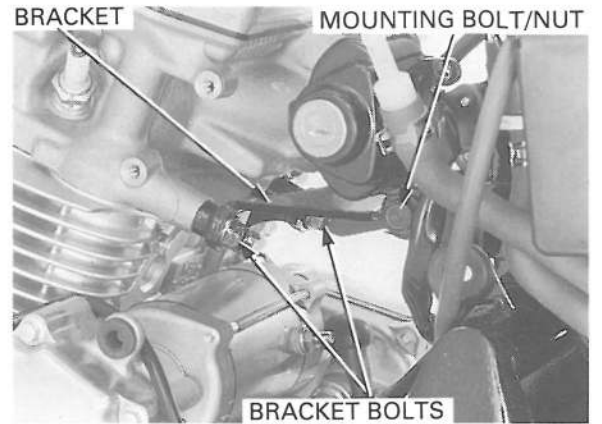

Connect the water pipes (thermostat housing-to-cylinder heads) to the cylinder heads.
Install and tighten the mounting bolts securely.

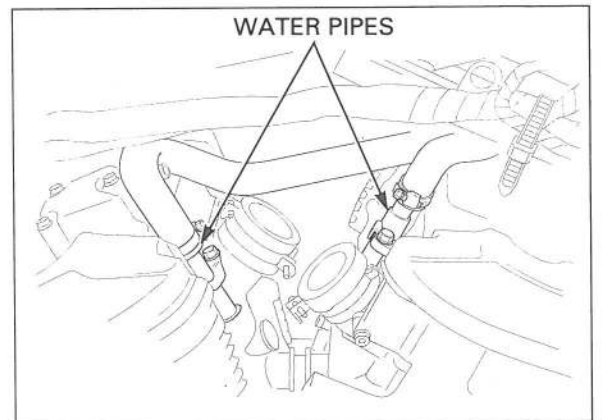

Connect the lower radiator hose to the radiator and tighten the radiator hose band securely.

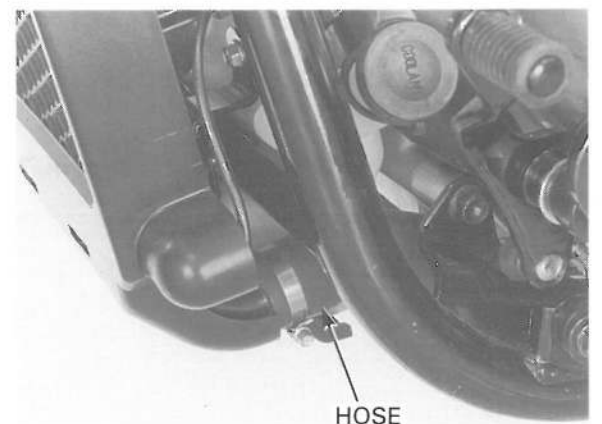

ENGINE REMOVAL/INSTALLATION

Route the alternator wire harness properly (refer to section 2).
Connect the alternator wire 3P (White) connector.

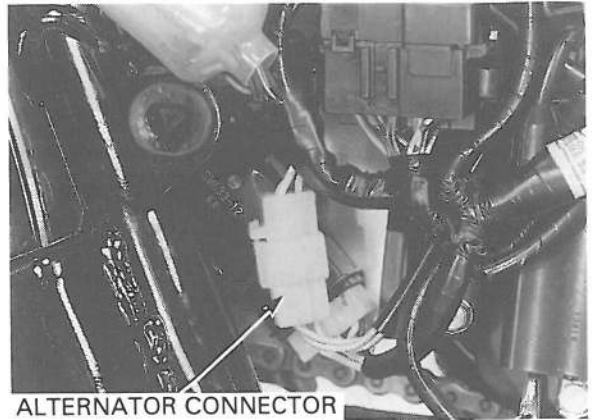

Route the ignition pulse generator wire harness properly (refer to section 2).
Connect the ignition pulse generator wire 2P (White) connector.

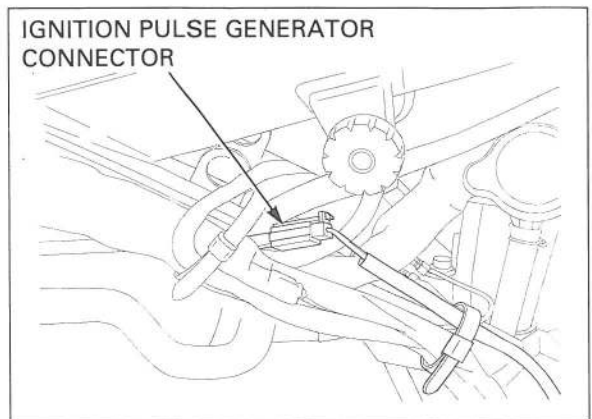

Connect the clutch cable to the clutch lifter arm.
Install the clutch cable holder and bolt.
Tighten the holder bolt securely.

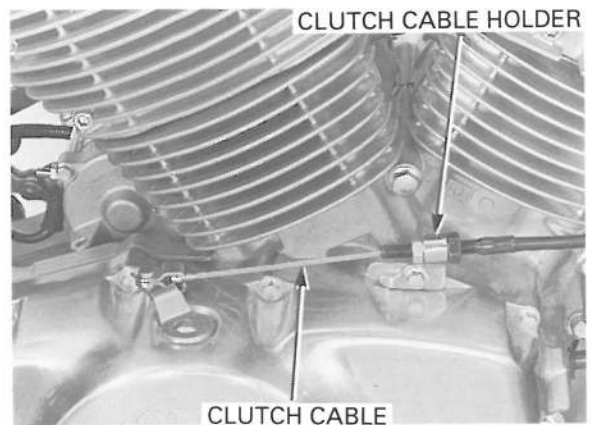

Connect the starter motor cable and ground cable to the starter motor.
Install and tighten the cable nut to the specified torque.

TORQUE: 10 N·m (1.0 kgf·m, 7 lbf·ft)

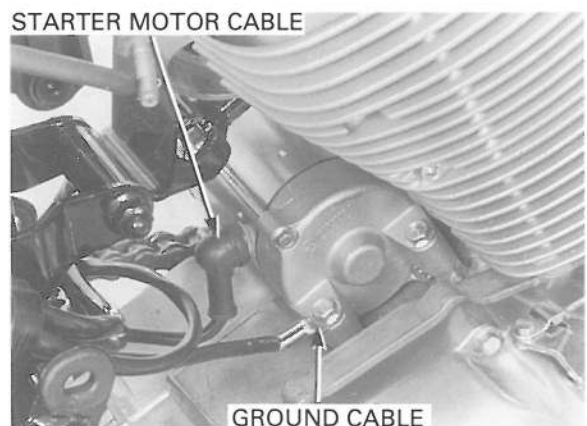

Route the neutral switch and oil pressure switch wire harness properly (refer to section 2).
Clean and apply a locking agent to the countershaft set plate bolt threads.
Install the countershaft oil seal set plate then tighten the mounting bolts securely.

Install the drive chain guide plate then tighten the mounting bolts to the specified torque.

TORQUE: 12 N·m (1.2 kgf·m, 9 lbf·ft)

Install the cord clammer then tighten the mounting bolts securely.

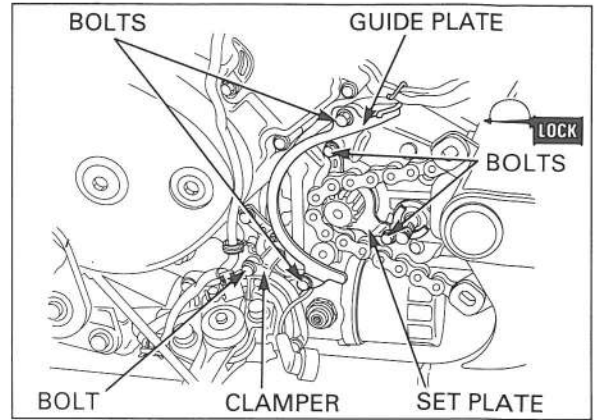

Connect the neutral switch and oil pressure switch cord terminal.
Install and tighten the oil pressure switch terminal screw to the specified torque.

TORQUE: 2 N·m (0.2 kgf·m, 1.4 lbf·ft)

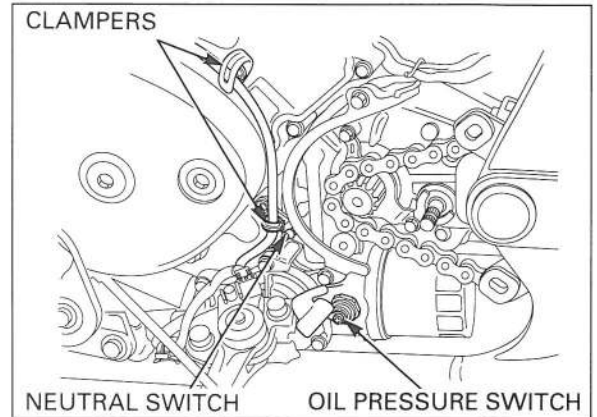

Connect the spark plug caps.

Install the following:

- Drive sprocket (see below)
- Right footpeg and rear brake pedal (page 14-16)
- Exhaust pipe/muffler (page 2-8)
- Sub-air cleaner housing (page 10-35)
- Carburetor (page 5-20)
- Air cleaner chamber (page 5-7)
- Air cleaner housing (page 5-4)
- Steering cover (page 2-3)
- Fuel tank (page 2-4)

Fill the engine oil (page 3-12)

Fill and bleed the cooling system (page 6-5).

Connect the battery negative cable to the battery terminal.

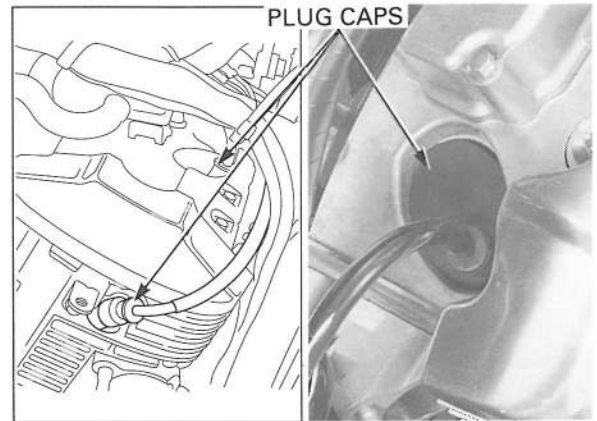

DRIVE SPROCKET INSTALLATION

Install the drive chain to the drive sprocket.
Install the drive sprocket to the countershaft with its marking side facing out.

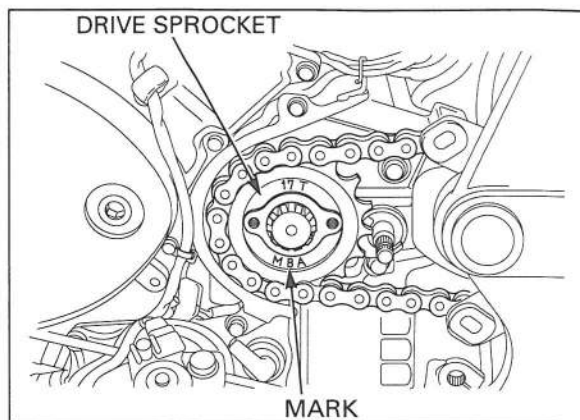

Install the drive sprocket setting plate onto the countershaft and align the bolt holes on the plate with the holes of the sprocket.

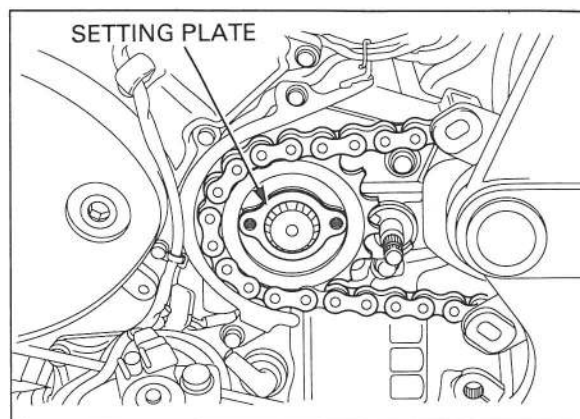

Install and tighten the drive sprocket setting plate bolts to the specified torque.

TORQUE: 10 N•m (1.0 kgf•m, 7 lbf•ft)

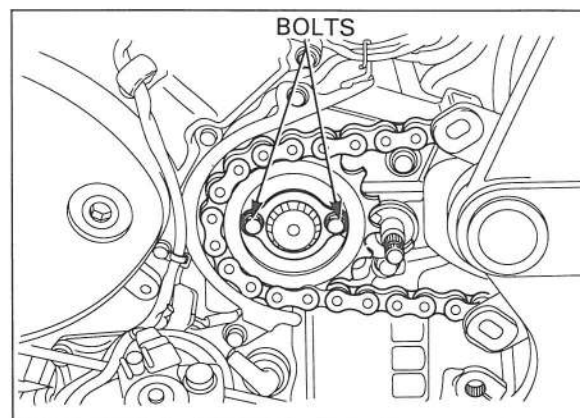

Install the gearshift arm to the gearshift spindle by aligning the punch mark on the spindle with the cut-out of the gearshift arm.

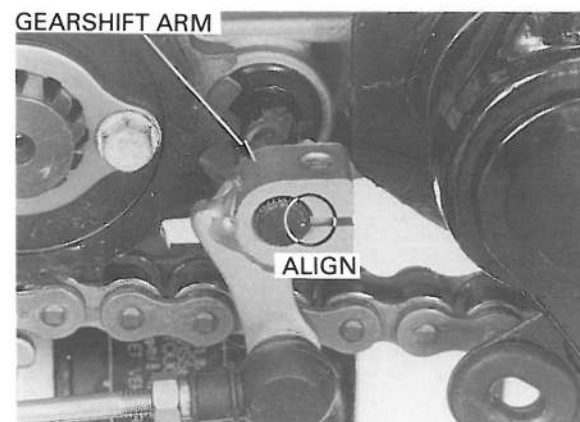

Install and tighten the gearshift arm pinch bolt to the specified torque.

TORQUE: 12 N·m (1.2 kgf·m, 9 lbf·ft)

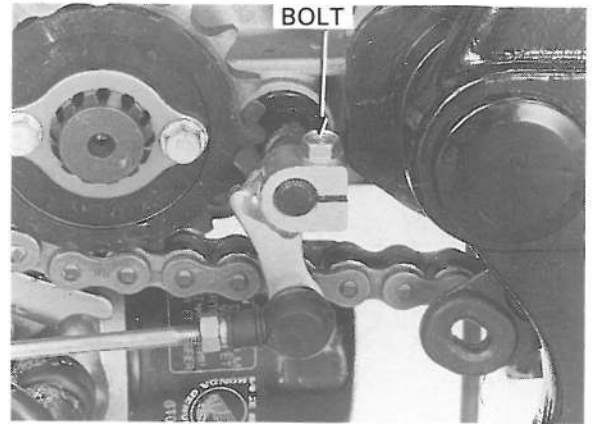

Install the collar, left rear cover, rubber, washer and bolt.
Tighten the bolt to the specified torque.

TORQUE: 12 N·m (1.2 kgf·m, 9 lbf·ft)

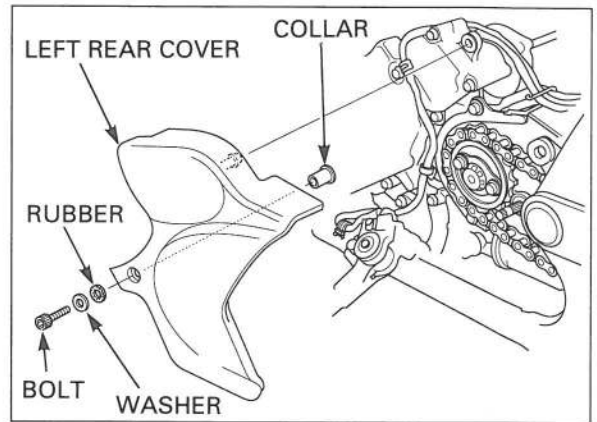

Install the washer and clip to the securely.

NOTE:

After installation, turn the clip clockwise and down behind the left rear cover.

Adjust the drive chain slack (page 3-18).

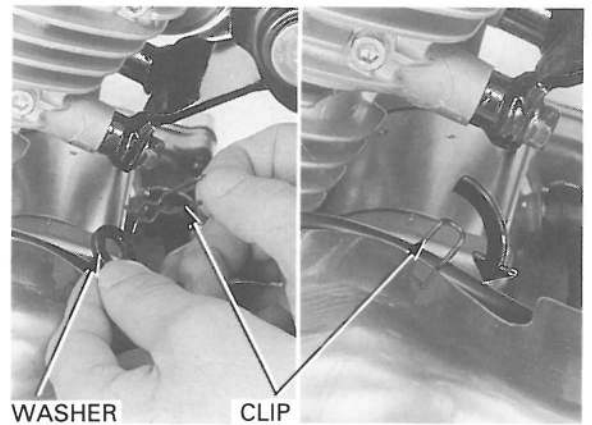

CLUTCH/GEARSHIFT LINKAGE

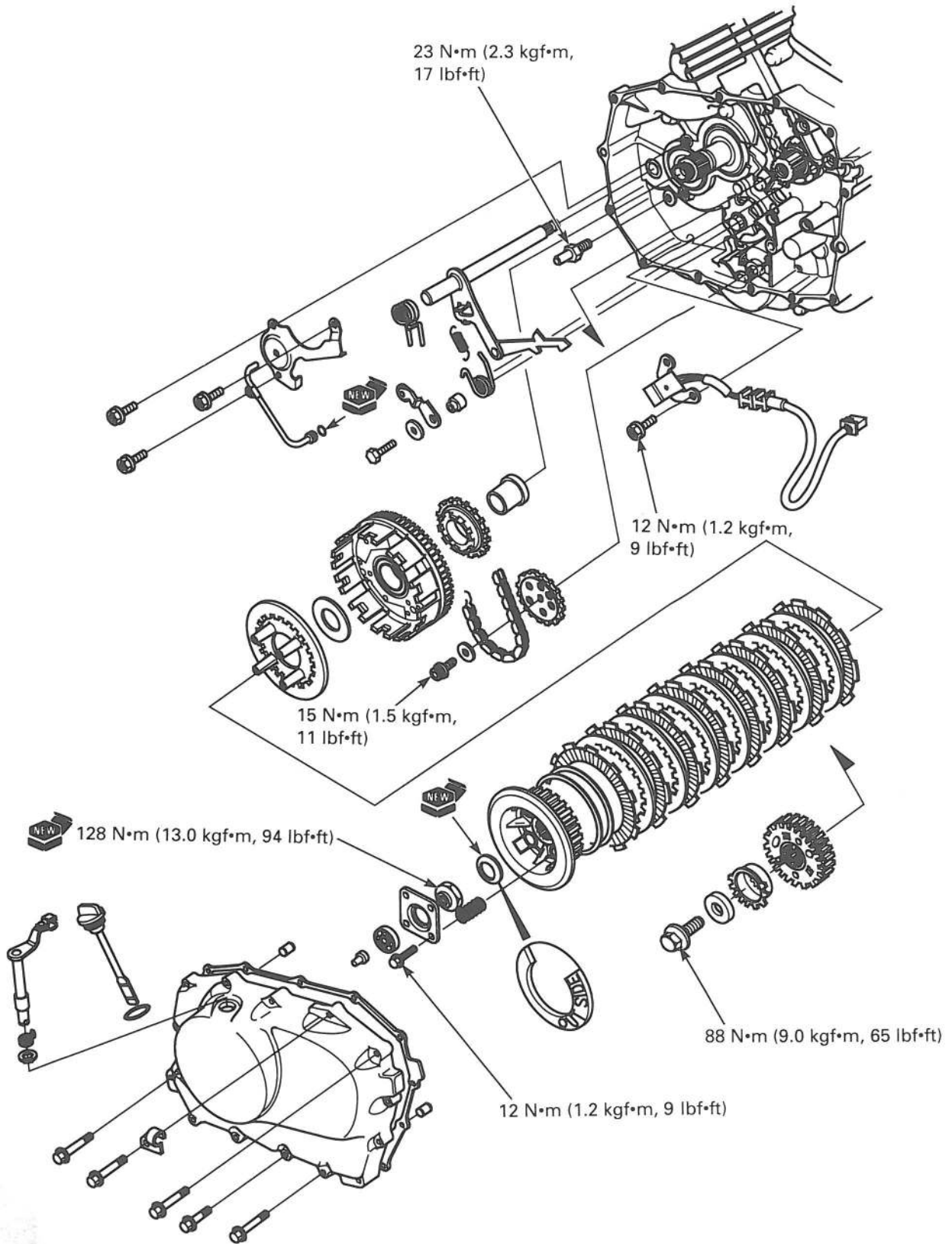

8. CLUTCH/GEARSHIFT LINKAGE

SERVICE INFORMATION	8-1	PRIMARY DRIVE GEAR	8-10
TROUBLESHOOTING	8-2	GEARSHIFT LINKAGE	8-12
RIGHT CRANKCASE COVER REMOVAL	8-3	CLUTCH INSTALLATION	8-17
CLUTCH REMOVAL	8-4	RIGHT CRANKCASE COVER INSTALLATION	8-21

SERVICE INFORMATION

GENERAL

- The clutch and gearshift linkage maintenance can be done with the engine in the frame.
- Engine oil viscosity and level, and the use of oil additives have an effect on clutch disengagement. Oil additives of kind are not recommended. When the clutch does not disengage or the motorcycle creeps with the clutch disengaged, inspect the engine oil viscosity and level before servicing the clutch system.
- Clean off any gasket material from the right crankcase cover surface.
- Be careful not to damage the crankcase cover mating surface when servicing.
- When removing or servicing the clutch and gearshift linkage, use care not to allow dust or dirt to enter the engine.
- The crankcase must be separated when the transmission requires service (Section 11).
- Refer to section 17 for ignition pulse generator inspection.

8

SPECIFICATIONS

Unit: mm (in)

ITEM		STANDARD	SERVICE LIMIT
Clutch lever free play		10 – 20 (3/8 – 3/4)	—
Clutch spring free length		45.5 (1.79)	43.9 (1.73)
Clutch disc thickness	A	2.62 – 2.78 (0.103 – 0.107)	2.3 (0.09)
	B	2.92 – 3.08 (0.115 – 0.121)	2.6 (0.10)
Clutch plate warpage		—	0.30 (0.012)
Clutch outer guide	I.D.	21.991 – 22.016 (0.8658 – 0.8668)	22.03 (0.867)
	O.D.	29.994 – 30.007 (1.1089 – 1.1814)	29.98 (1.180)
Oil pump drive sprocket I.D.		30.025 – 30.145 (1.1821 – 1.1868)	30.15 (1.187)
Mainshaft O.D. at clutch outer guide		21.967 – 21.980 (0.8648 – 0.8654)	21.95 (0.864)

TORQUE VALUES

Clutch lifter plate bolt	12 N•m (1.2 kgf•m, 9 lbf•ft)	
Clutch center lock nut	128 N•m (13.0 kgf•m, 94 lbf•ft)	Apply oil to the threads and seating surface
Primary drive gear bolt	88 N•m (9.0 kgf•m, 65 lbf•ft)	Stake
Ignition pulse generator bolt	12 N•m (1.2 kgf•m, 9 lbf•ft)	Apply oil to the threads and seating surface
Oil pump driven sprocket bolt	15 N•m (1.5 kgf•m, 11 lbf•ft)	Apply a locking agent to the threads
Gearshift return spring pin	23 N•m (2.3 kgf•m, 17 lbf•ft)	Apply a locking agent to the threads
Gearshift pedal pivot bolt	34 N•m (3.5 kgf•m, 25 lbf•ft)	
Footpeg set arm bolt	26 N•m (2.7 kgf•m, 20 lbf•ft)	

CLUTCH/GEARSHIFT LINKAGE

TOOLS

Gear holder	07724-0010100
Attachment, 37 X 40 mm	07746-0010200
Pilot, 12 mm	07746-0040200
Pilot, 30 mm	07746-0040700
Attachment, 28 X 30 mm	07946-1870100
Clutch center holder	07JMB-MN50301 or 07HGB-001010B 07HGB-001010A and 07HGB-001020B or 07HGB-001020A (U.S.A. only)

TROUBLESHOOTING

Clutch lever too hard

- Damaged, kinked or dirty clutch cable
- Faulty clutch lifter plate bearing
- Damaged clutch lifter mechanism
- Improperly routed clutch cable

Clutch will not disengage or motorcycle creeps with clutch disengaged

- Too much clutch lever free play
- Warped clutch plates
- Loose clutch center lock nut
- Engine oil too high, improper oil viscosity

Clutch slips

- Clutch lifter sticking
- Worn clutch discs
- Weak clutch springs
- No clutch lever free play

Hard to shift

- Improper clutch operation or incorrect clutch adjustment
- Bent or damaged shift forks (Section 12)
- Bent shift fork shaft (Section 12)
- Bent or damaged gearshift spindle
- Damaged shift drum cam grooves

Transmission jumps out of gear

- Worn gear dogs or slots
- Bent shift fork shaft (Section 12)
- Broken shift drum stopper arm
- Worn or bent shift forks (Section 12)
- Broken shift linkage return spring

RIGHT CRANKCASE COVER REMOVAL

Drain the engine oil (page 3-12).
Remove the exhaust pipe/muffler (page 2-7).
Remove the right footpeg and rear brake pedal (page 14-15).

Remove the right crankcase bolts, clutch cable guide and cover.
Disconnect the clutch cable from the clutch lifter arm.

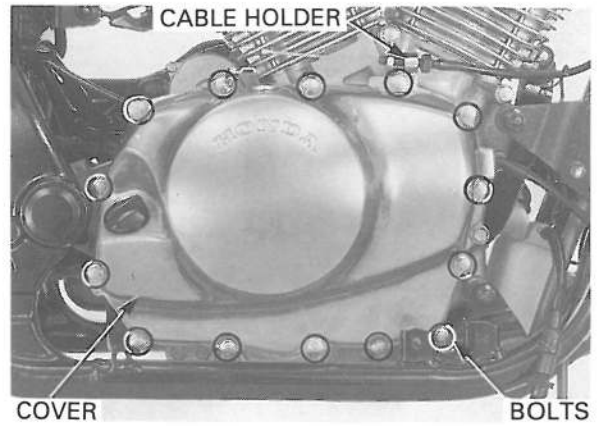

Remove the dowel pins and gasket.

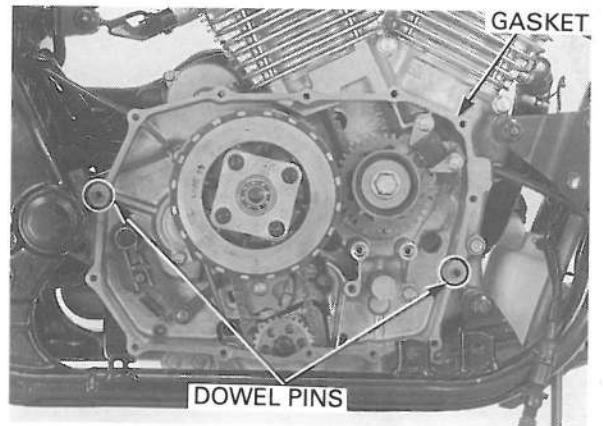

DISASSEMBLY

Remove the clutch lifter piece.

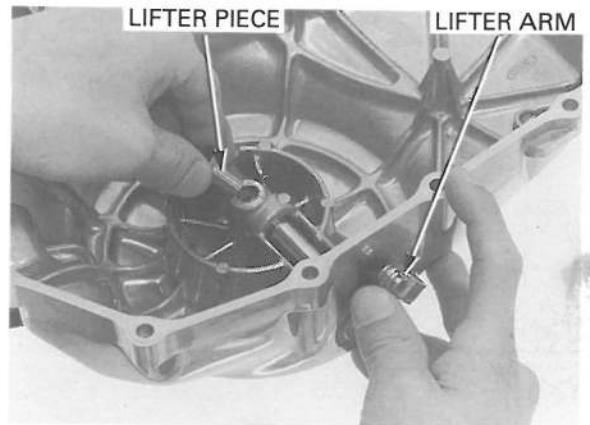

Remove the snap ring and return spring from the right crankcase cover.

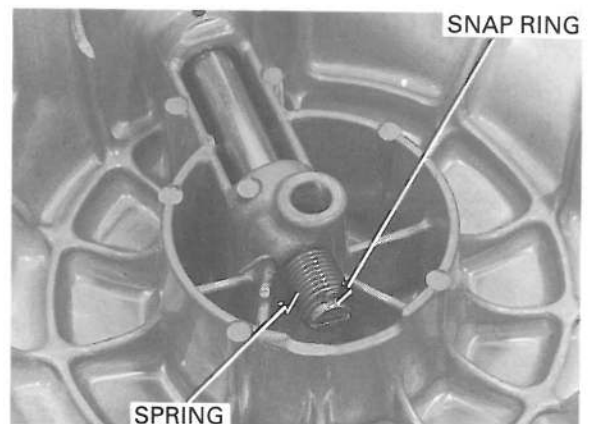

CLUTCH/GEARSHIFT LINKAGE

Remove the clutch lifter arm.

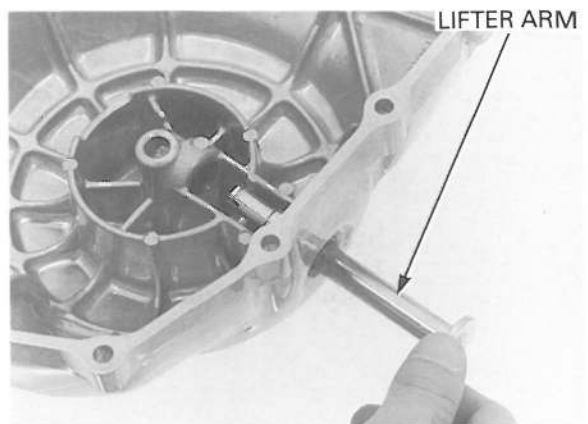

INSPECTION

Check the dust seal fatigue or damage.
Check the needle bearing for wear, damage or loose fit.
Replace these parts if necessary.

NOTE:

If the dust seal replacement is required, press the dust seal to the case surface.

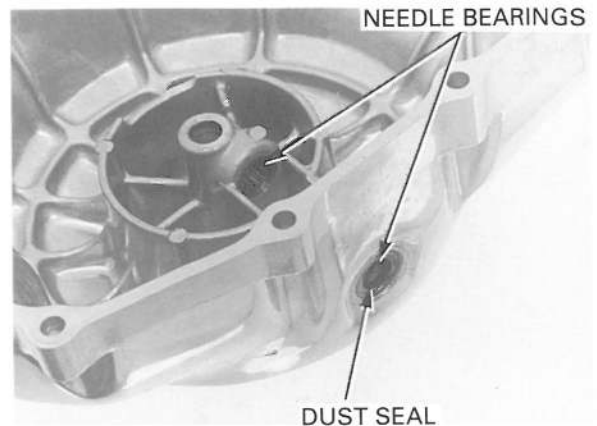

Check the clutch lifter arm for damage or bending.
Check the spring for fatigue or damage.
Replace these parts if necessary.

Apply grease to the clutch lifter arm sliding surface.
Apply grease to the dust seal lips and needle bearing.

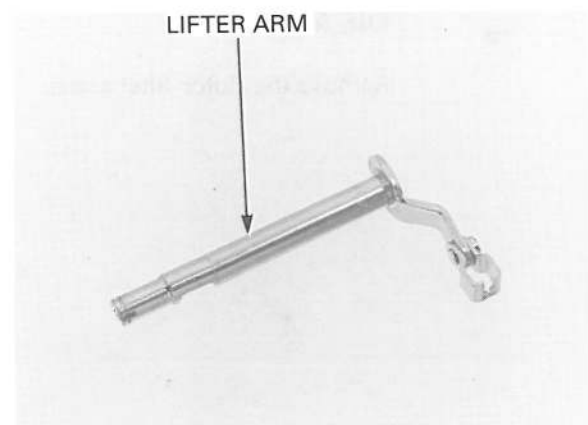

CLUTCH REMOVAL

If the oil pump driven sprocket will be removed, loosen the driven sprocket bolt while the clutch is still installed.

Remove the right crankcase cover (page 8-3).
Loosen the clutch lifter plate bolts in a crisscross pattern in 2 or 3 steps.
Remove the lifter plate/bearing and clutch springs.

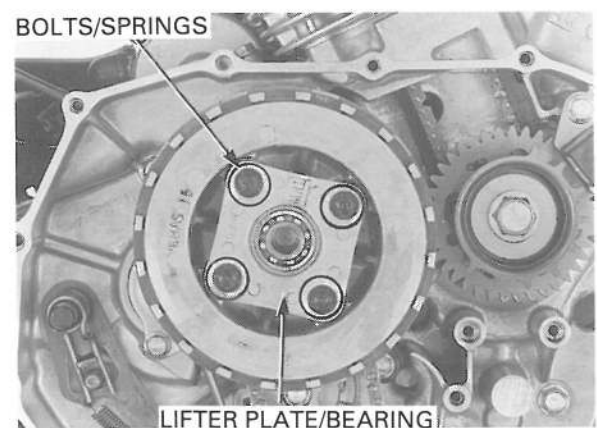

Unstake the clutch center lock nut.

CAUTION:

Be careful not to damage the mainshaft threads.

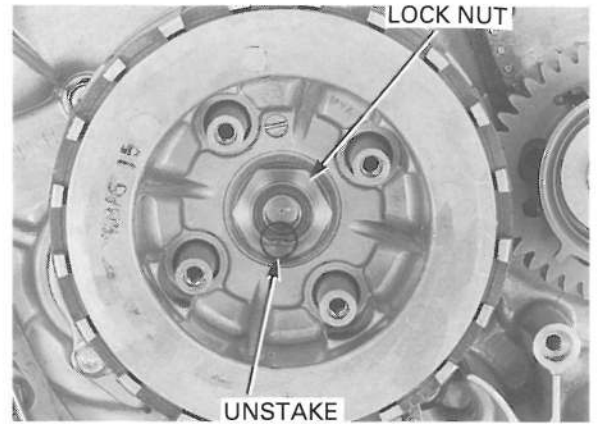

Hold the pressure plate with the clutch center holder and loosen the clutch center lock nut.

TOOL:

Clutch center holder

07JMB-MN50301 or
07HGB-001010B
07HGB-001010A and
07HGB-001020B or
07HGB-001020A
(U.S.A. only)

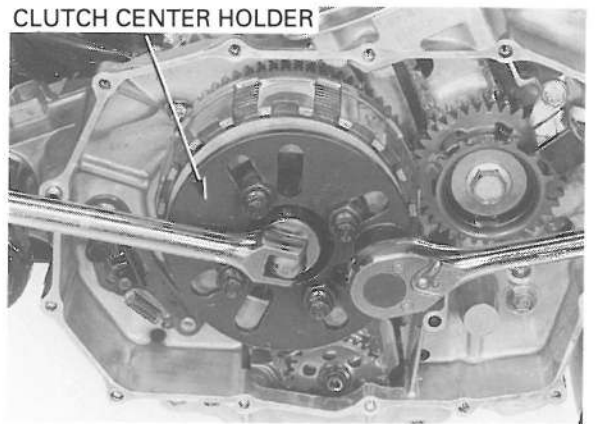

Remove the clutch center lock nut, spring washer and washer.

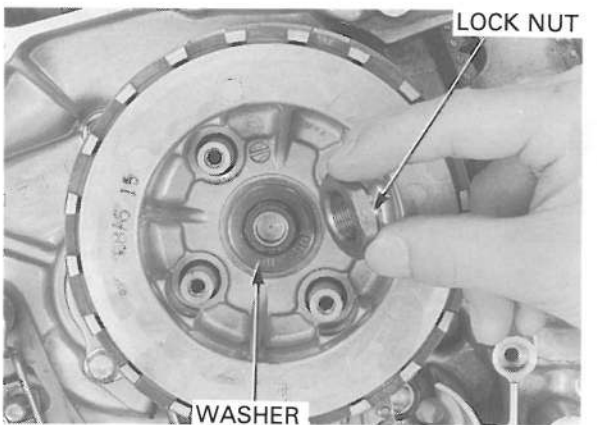

Remove the clutch center.
Remove the judder spring, spring seat, clutch discs and clutch plates.
Remove the pressure plate.

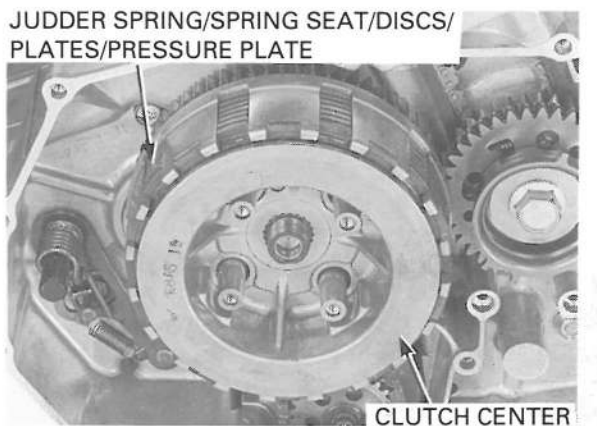

CLUTCH/GEARSHIFT LINKAGE

Remove the washer.

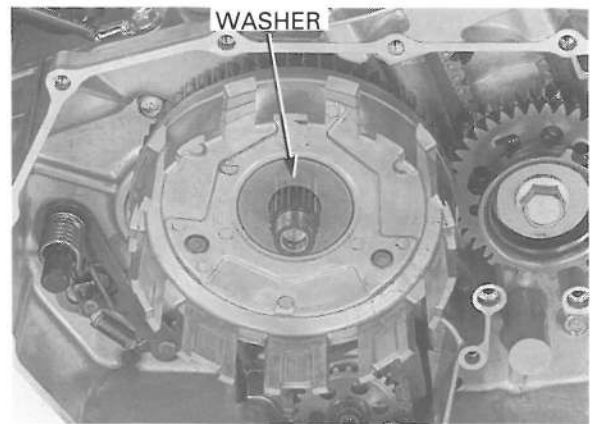

Align the primary drive gear and sub-gear teeth (anti-back-lash gear) with a slotted head screwdriver. Remove the clutch outer.

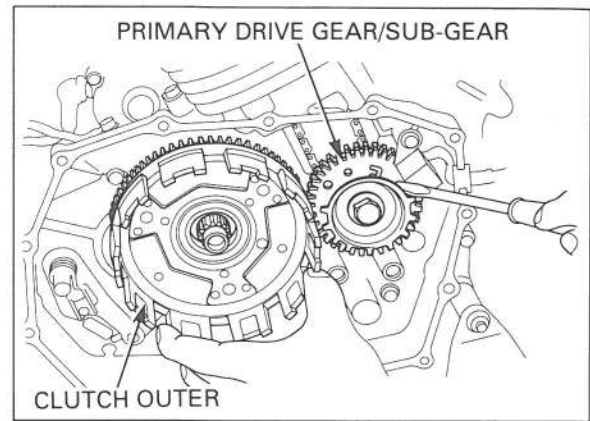

Remove the oil pump driven sprocket bolt and washer.

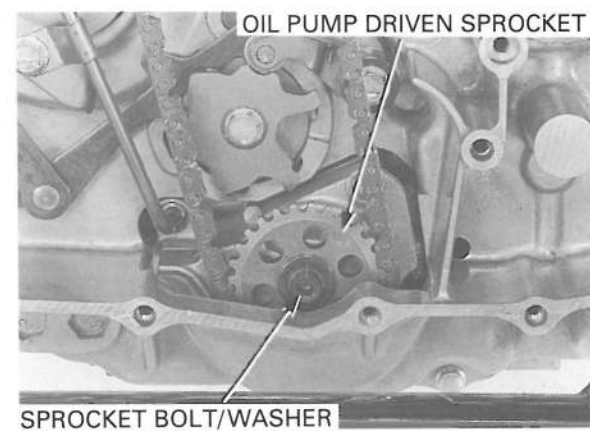

Remove the oil pump drive sprocket, driven sprocket and oil pump drive chain as a set.

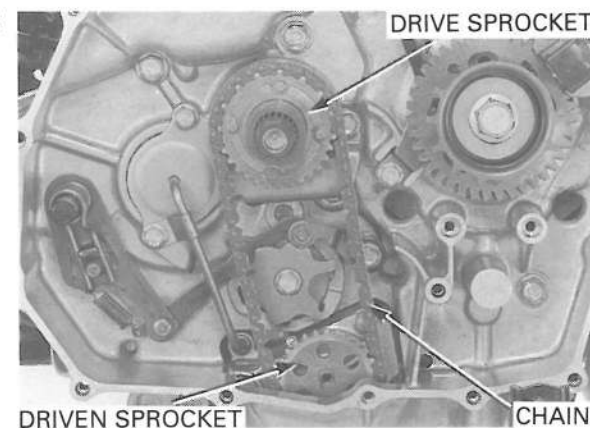

Remove the clutch outer guide.

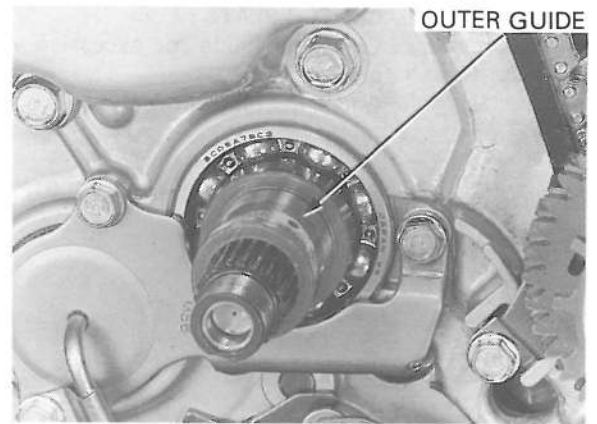

INSPECTION

LIFTER PLATE BEARING

Check the lifter plate bearing for damage. Turn the bearing inner race with your finger. The bearing should turn smoothly and quietly without play. Also check that the bearing outer race fits in the plate. Replace the bearing if necessary.

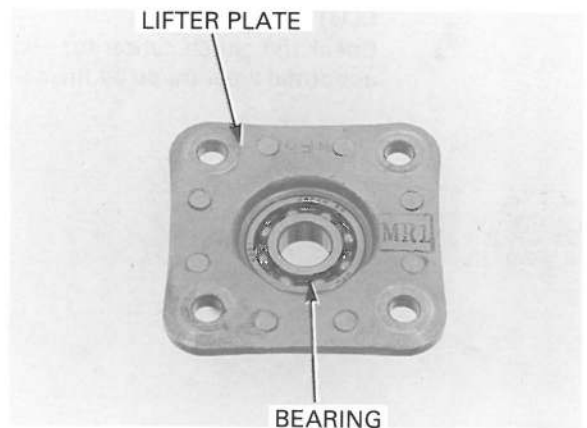

CLUTCH SPRING

Replace the clutch springs as a set.

Measure the clutch spring free length.

SERVICE LIMIT: 43.9 mm (1.73 in)

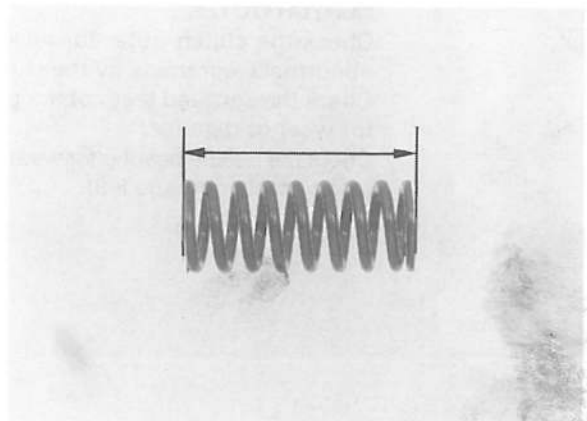

CLUTCH DISC

Replace the discs and plates as a set.

Check the clutch discs for signs of scoring or discoloration.

Measure the thickness of the discs.

**SERVICE LIMITS: Disc A: 2.3 mm (0.09 in)
Disc B: 2.6 mm (0.10 in)**

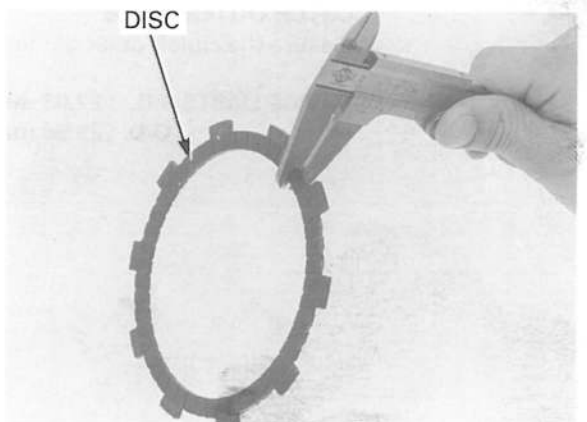

CLUTCH/GEARSHIFT LINKAGE

Replace the discs
and plates as a
set.

CLUTCH PLATE

Check the plate for excessive warpage or discoloration.
Check the plate warpage on a surface plate using a feeler gauge.

SERVICE LIMIT: 0.30 mm (0.012 in)

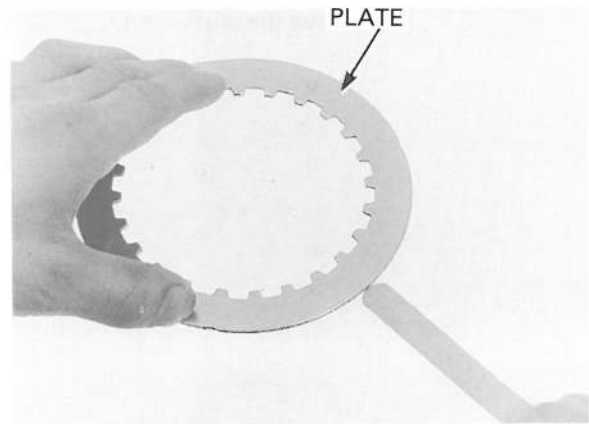

CLUTCH CENTER

Check the clutch center for nicks, indentations or abnormal wear made by the clutch plates.

CLUTCH CENTER

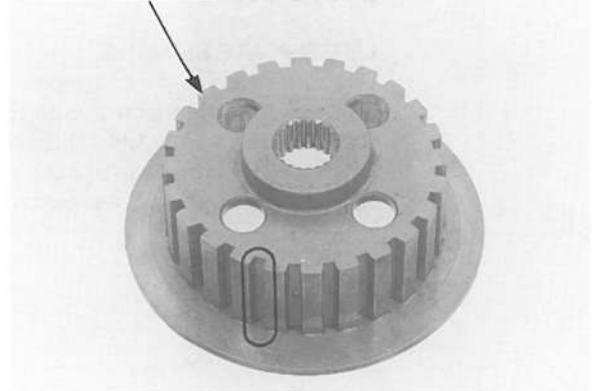

CLUTCH OUTER

Check the clutch outer for nicks, indentations or abnormal wear made by the clutch discs.
Check the serrated teeth of the primary driven gear for wear or damage.
Check the needle bearing for wear or damage; replace as a necessary (page 8-9).

CLUTCH OUTER

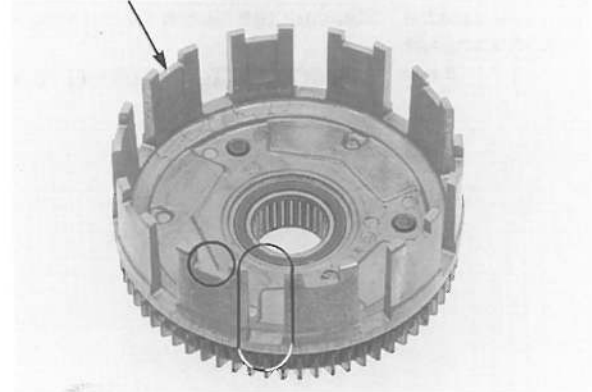

CLUTCH OUTER GUIDE

Measure the clutch outer guide.

SERVICE LIMITS: I.D. : 22.03 mm (0.867 in)
O.D. : 29.98 mm (1.180 in)

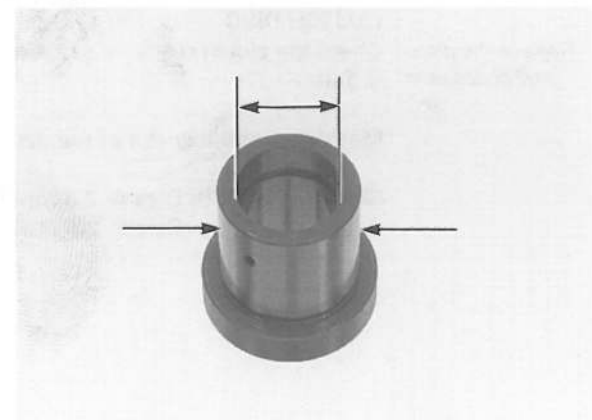

OIL PUMP DRIVE SPROCKET

Check the oil pump drive sprocket for damage.
Measure the I.D. of the drive sprocket.

SERVICE LIMIT: 30.15 mm (1.187 in)

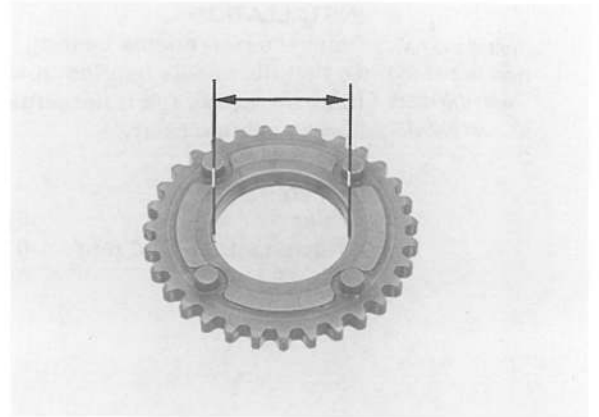

MAINSHAFT

Measure the mainshaft O.D. at the clutch outer guide.

SERVICE LIMIT: 21.95 mm (0.864 in)

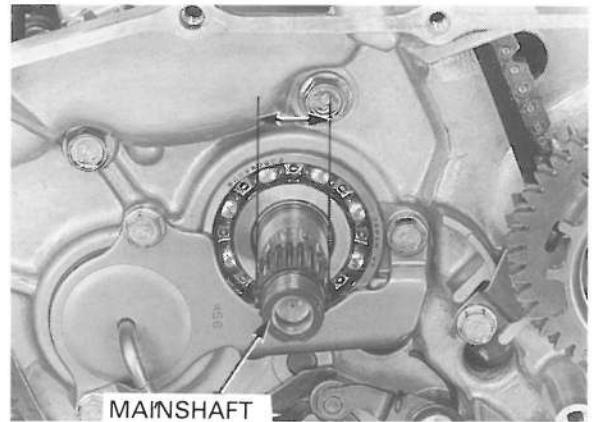

JUDDER SPRING, SPRING SEAT

Check the spring seat and judder spring for distortion,
wear or damage.

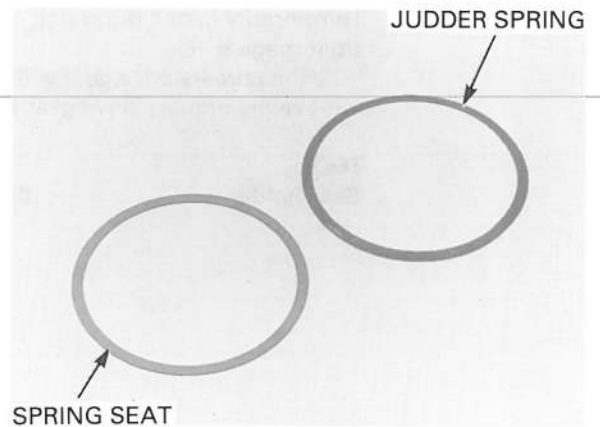

CLUTCH OUTER NEEDLE BEARING REPLACEMENT

REMOVAL

Press the needle bearing out of the clutch outer.

TOOLS:

Driver	07749-0010000
Attachment, 37 X 40 mm	07746-0010200
Pilot, 30 mm	07746-0040700

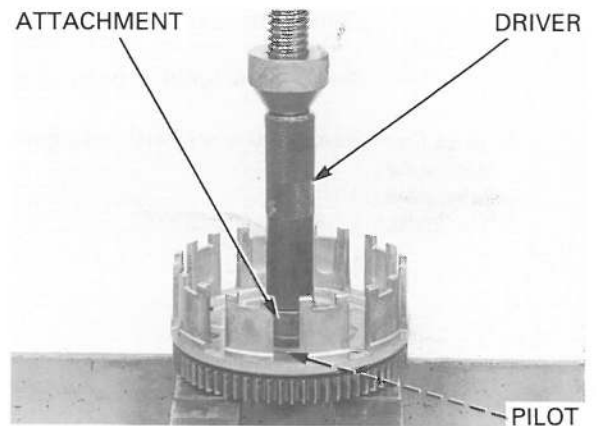

CLUTCH/GEARSHIFT LINKAGE

Install the new needle bearing with the mark facing out.

INSTALLATION

Press the new needle bearing into the clutch outer so that the needle bearing outer surface is 1.0 mm (0.03 in). below the outer edge of the clutch outer needle bearing cavity.

TOOLS:

Driver

07749-0010000

Attachment, 37 X 40 mm

07746-0010200

Pilot, 30 mm

07746-0040700

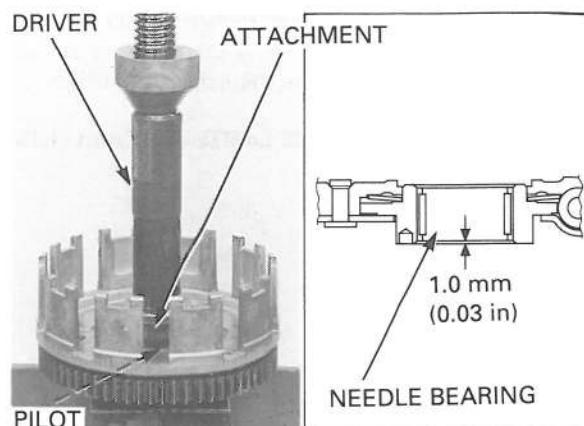

PRIMARY DRIVE GEAR

REMOVAL

Remove the clutch (page 8-4).

Remove the ignition pulse generator mounting bolts.
Remove the ignition pulse generator and grommets.

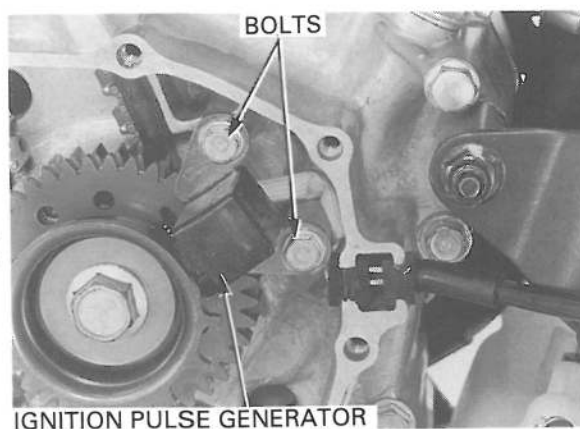

Temporarily install the clutch outer onto the mainshaft (page 8-18).

Hold the primary drive gear with the gear holder and remove the primary drive gear bolt and washer.

TOOL:

Gear holder

07724-0010100

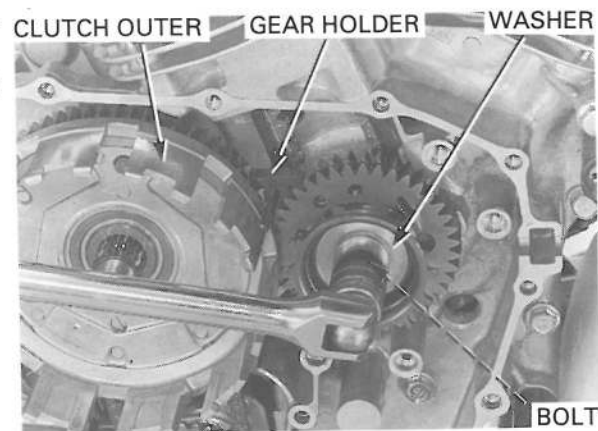

Remove the clutch outer and gear holder (page 8-6).

Remove the ignition pulse generator rotor.

Be careful not to loose the disassembled parts.

Remove the primary drive gear as assembly.

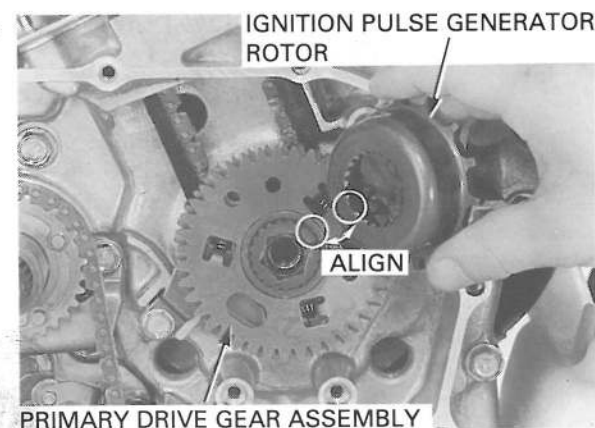

INSPECTION

Check the serrated teeth of the primary drive gear for wear or damage.
 Check the serrated teeth of the sub-gear for wear or damage.
 Check the primary drive gear spring and friction spring for fatigue or damage.

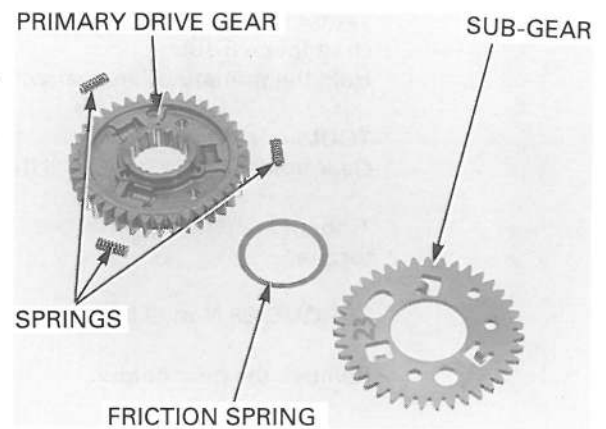

INSTALLATION

Align the three holes on the sub-gear and primary drive gear.

Assemble the primary drive gear, primary drive gear spring, friction spring and sub-gear as shown.

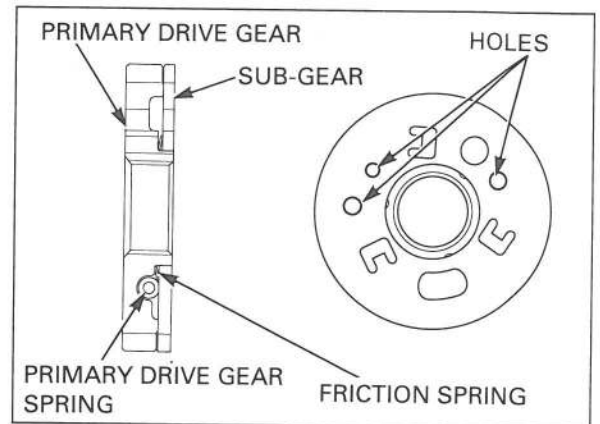

The primary drive gear will only go on in one position because of the extra wide aligning spline.

Install the primary drive gear assembly with the sub-gear side facing out.

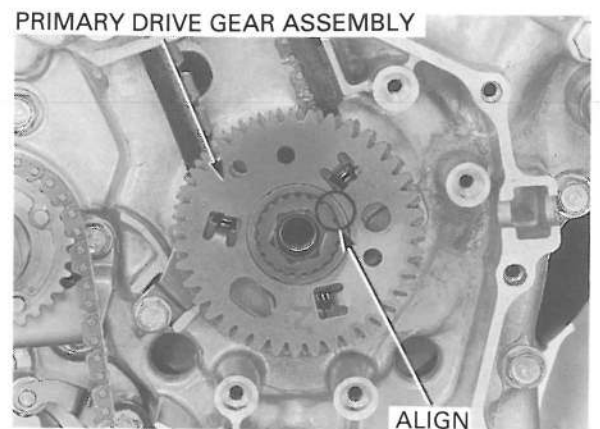

The ignition pulse generator rotor will only go on in one position because of the extra wide aligning spline.

Install the ignition pulse generator rotor.
 Apply engine oil to the primary drive gear bolt threads and seating surface.
 Install the washer and primary drive gear bolt.

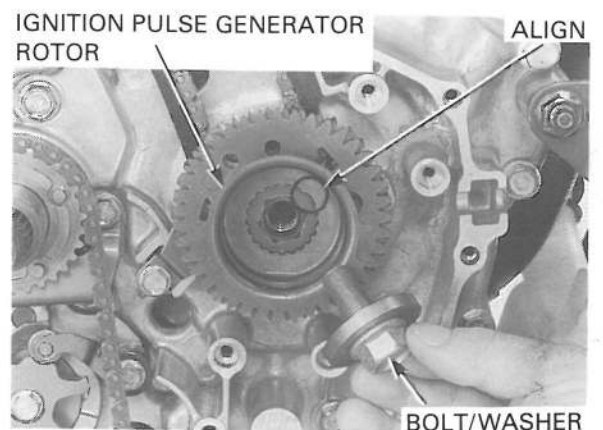

CLUTCH/GEARSHIFT LINKAGE

Temporarily install the clutch outer onto the mainshaft (page 8-18).
Hold the primary drive gear with the gear holder.

TOOL:

Gear holder 07724-0010100

Tighten the primary drive gear bolt to the specified torque.

TORQUE: 88 N·m (9.0 kgf·m, 65 lbf·ft)

Remove the gear holder.

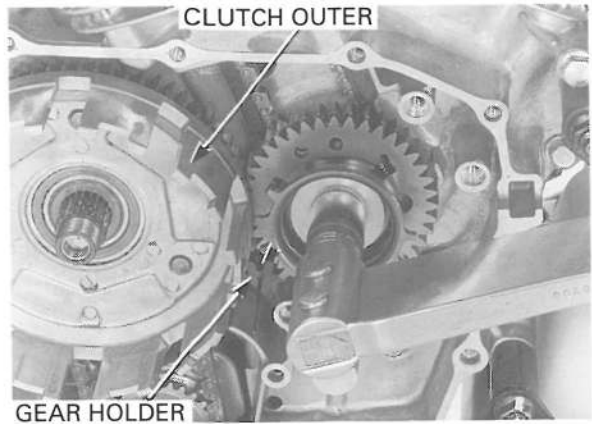

Apply a locking agent to the ignition pulse generator bolt threads.
Install the ignition pulse generator and tighten the bolts to the specified torque.

TORQUE: 12 N·m (1.2 kgf·m, 9 lbf·ft)

Install the clutch (page 8-18).

NOTE:

If the ignition pulse generator wire grom-mets were removed from the case groove, reinstall them securely.

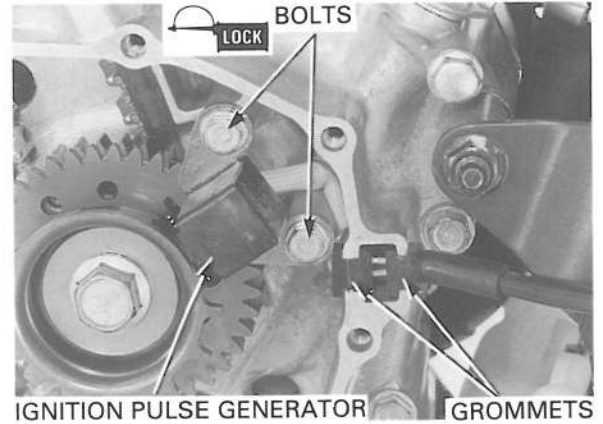

GEARSHIFT LINKAGE

REMOVAL

Remove the left rear cover (page 7-3).
Remove the gearshift arm pinch bolt and gearshift arm from the gearshift spindle.

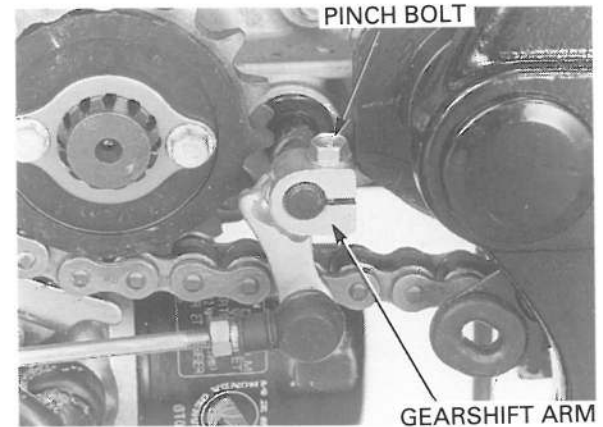

Remove the bolts and left footpeg as assembly.

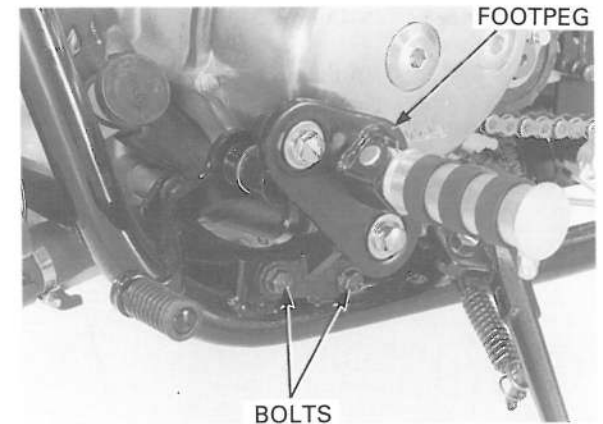

Remove the pivot bolt and gearshift pedal/arm from the left footpeg.

- Remove the following:
- Right crankcase cover (page 8-3)
 - Clutch (page 8-4)
 - Oil pump drive chain (page 8-6)

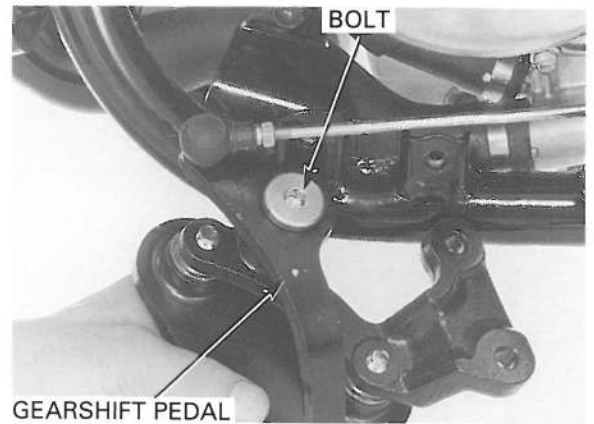

Remove the oil pipe stay mounting bolt and remove the oil pipe mounting bolt.
Pull the oil pipe out of the stay and oil pump.

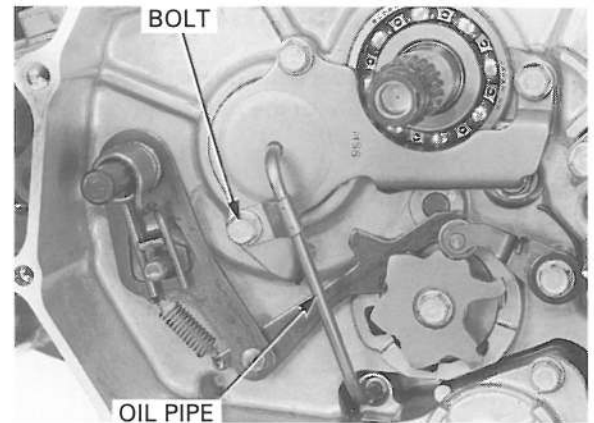

Remove the O-ring from the oil pipe.

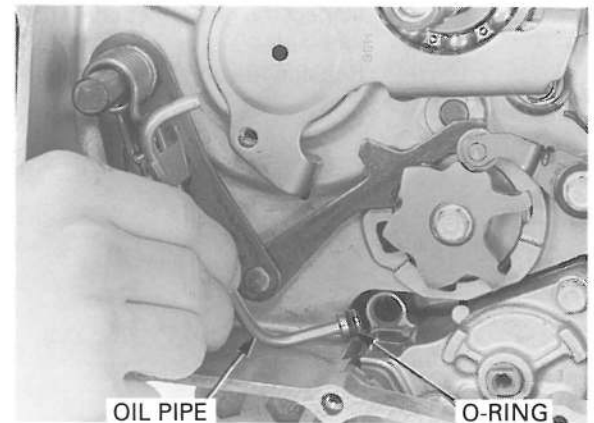

Remove the gearshift spindle from the crankcase while unhooking the shifter arm from the gearshift cam plate.

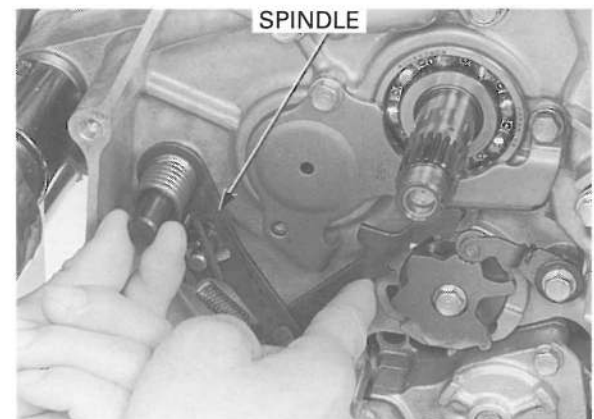

CLUTCH/GEARSHIFT LINKAGE

Remove the bolt, washer, gearshift drum stopper, collar and spring.

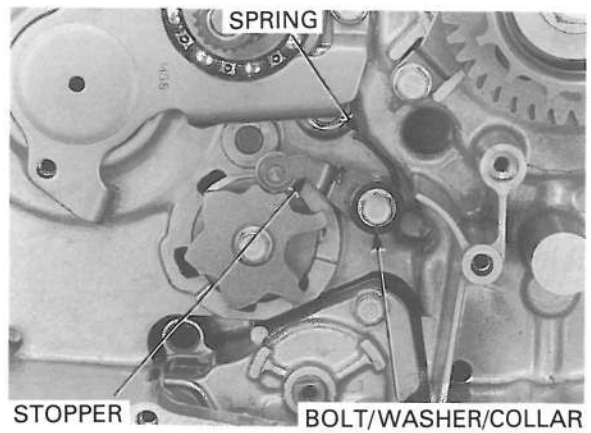

INSPECTION

Check the gearshift spindle for wear or damage.
Check the return spring for fatigue or damage.

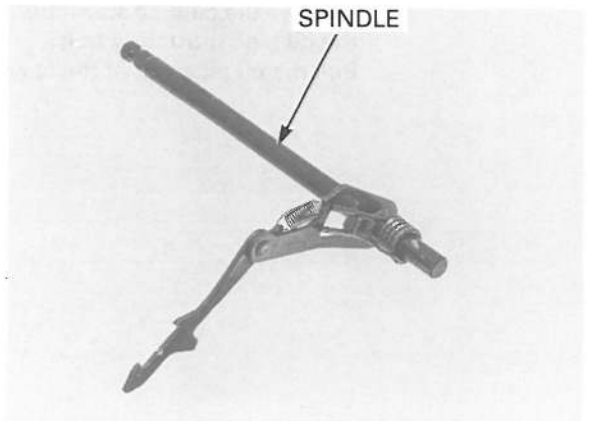

Inspect the gearshift pedal shaft for damage or loose lock nuts.
Replace the shaft if necessary.

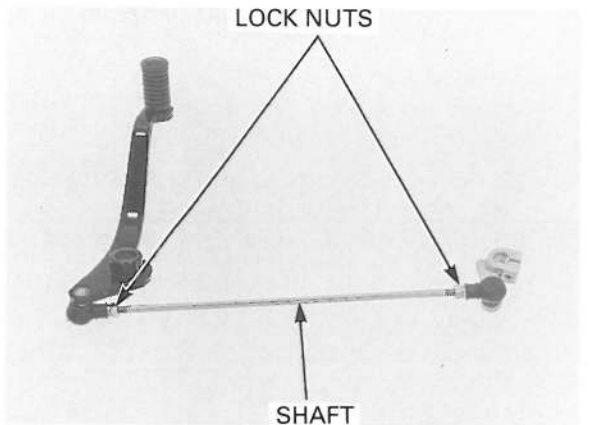

INSTALLATION

Install the collar, spring, gearshift drum stopper, washer and bolt as shown.

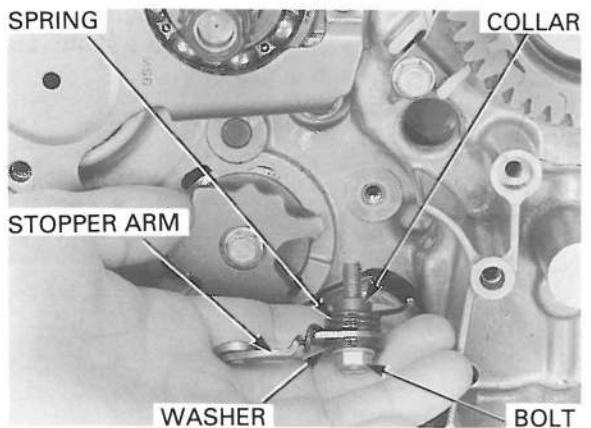

Hold the stopper arm with the screwdriver, and tighten the bolt securely as shown.

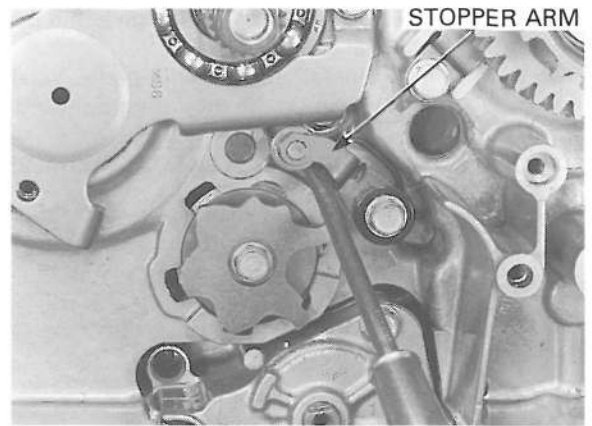

Install the gearshift spindle, aligning the return spring ends with the pin in the case.

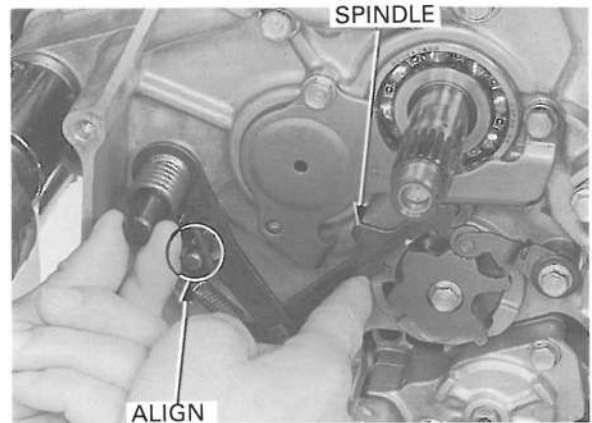

Apply oil to the new O-ring. Install the oil pipe with a new O-ring onto the oil pipe stay and oil pump.

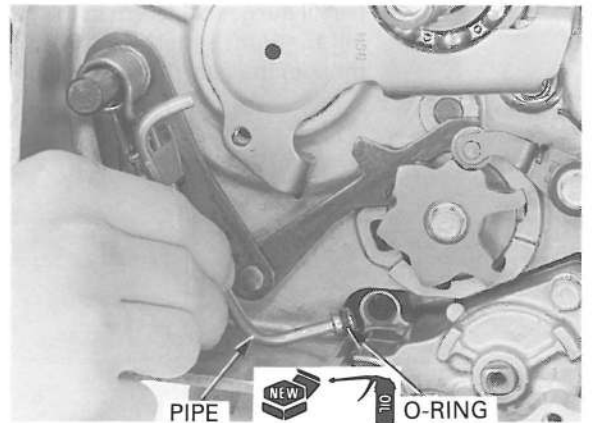

Install and tighten the bolt securely.

Install the following:

- Oil pump drive chain, clutch (page 8-17)
- Right crankcase cover (page 8-21)

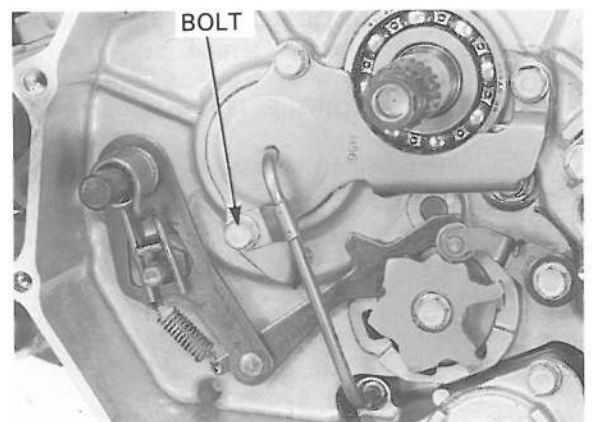

CLUTCH/GEARSHIFT LINKAGE

Apply grease to the gearshift pedal pivot bolt sliding area.

Install the gearshift pedal, washer and pivot bolt.
Tighten the mounting bolt to the specified torque.

TORQUE: 34 N·m (3.5 kgf·m, 25 lbf·ft)

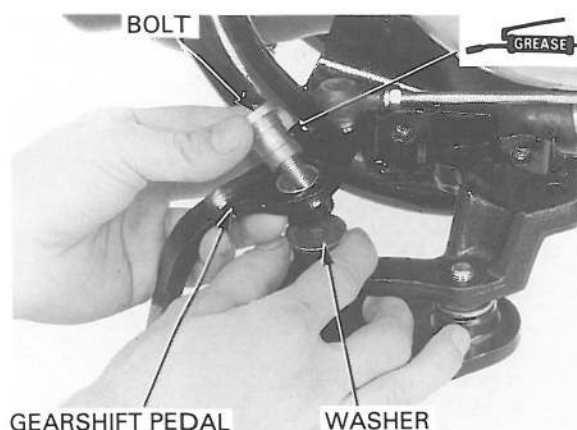

Install the left footpeg assembly.
Install and tighten the mounting bolts to the specified torque.

TORQUE: 26 N·m (2.7 kgf·m, 20 lbf·ft)

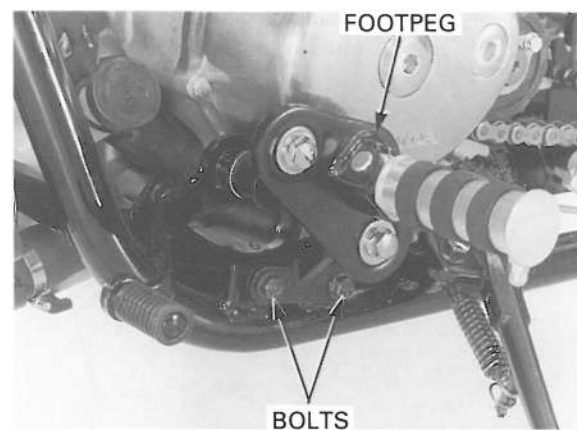

Install the gearshift arm to the gearshift spindle aligning the punch mark on the spindle with the punch mark of the gearshift arm.

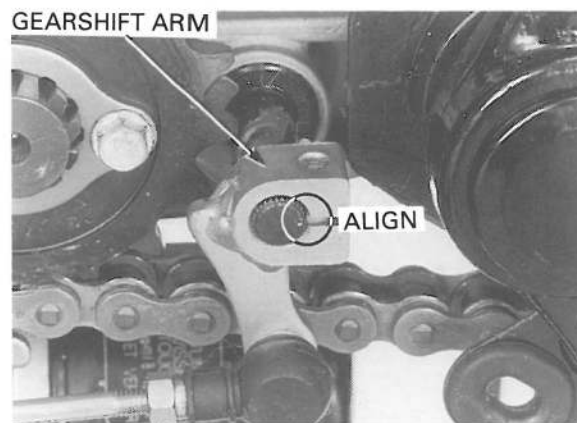

Install and tighten the gearshift arm pinch bolt to the specified torque.

TORQUE: 12 N·m (1.2 kgf·m, 9 lbf·ft)

Install the left rear cover (page 7-14).

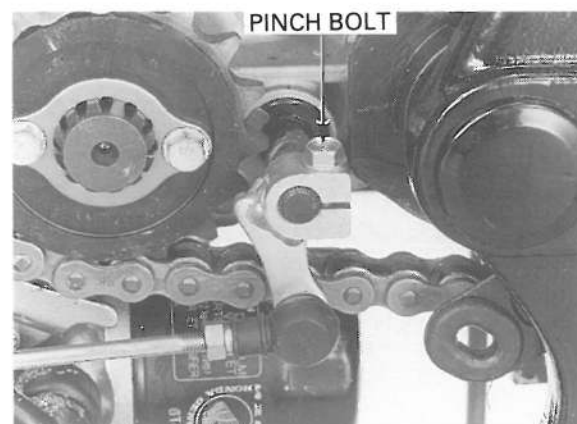

CLUTCH INSTALLATION

NOTE:

If the oil pump driven sprocket is removed, tighten the driven sprocket bolt to the specified torque after clutch installation.

Install the oil pump drive sprocket with its boss side facing out. Apply molybdenum disulfide oil to the clutch outer guide outer surface.
 Install the clutch outer guide to the mainshaft.
 Install the oil pump drive sprocket to the clutch outer guide.

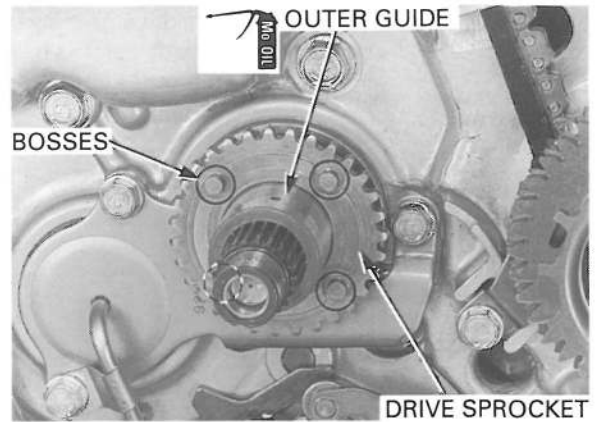

Install the oil pump drive chain to the oil pump drive and driven sprocket.
 Install the oil pump driven sprocket with the "IN" mark on the driven sprocket facing inside.

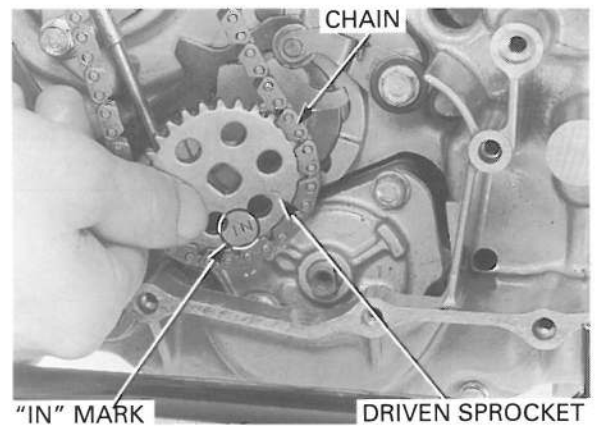

Align the flat surfaces of the driven sprocket hole and oil pump shaft end.

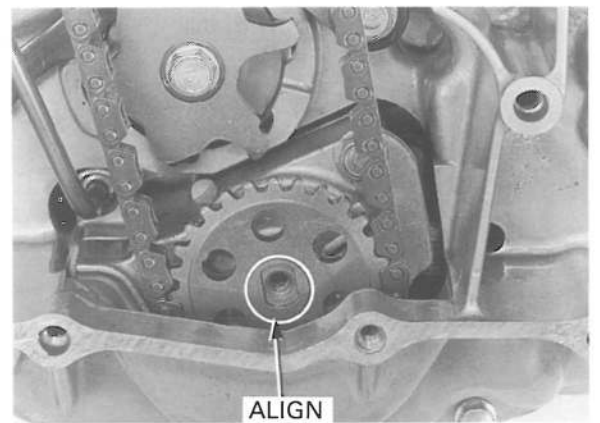

Clean and apply a locking agent to the oil pump driven sprocket bolt threads.
 Install the oil pump driven sprocket bolt.

NOTE:

If the oil pump driven sprocket is removed, tighten the driven sprocket bolt to the specified torque after clutch installation.

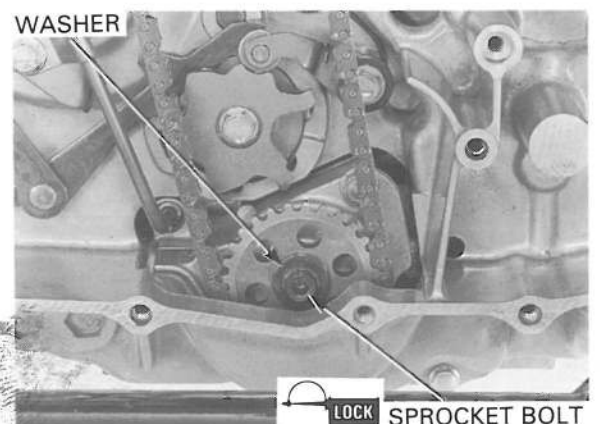

CLUTCH/GEARSHIFT LINKAGE

Align the primary drive gear and sub-gear teeth (anti-back-lash gear) with a slotted head screwdriver. Install the clutch outer onto the mainshaft.

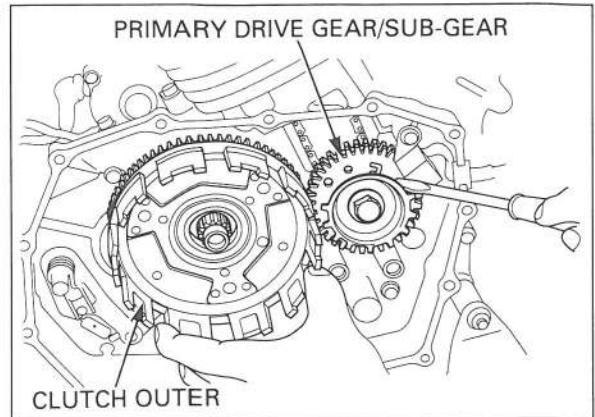

NOTE:

Align the holes in the clutch outer with the bosses on the oil pump drive sprocket while turning the sprocket with the chain and pushing the clutch outer onto the shaft.

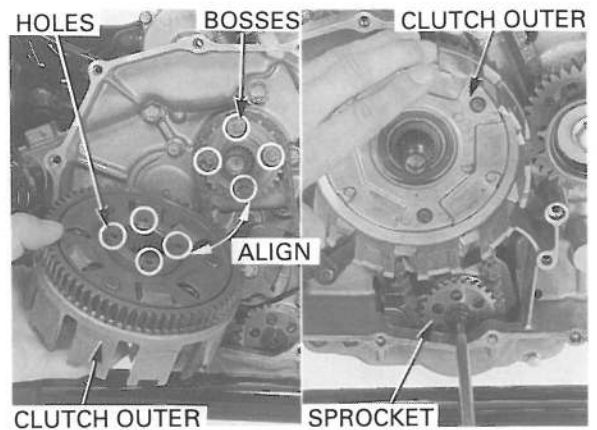

Install the thrust washer onto the mainshaft.

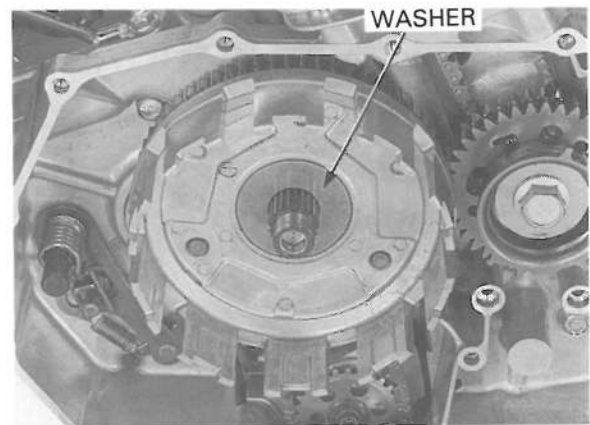

Coat the clutch discs and clutch plates with clean engine oil. Install the spring seat, judder spring and clutch disc B on the clutch center as shown.

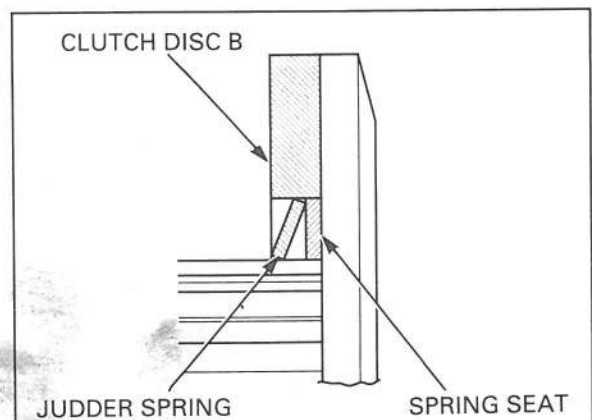

Install the seven clutch plates and seven clutch discs A alternately, and then install the pressure plate to the clutch center. Install them in the clutch outer as an assembly.

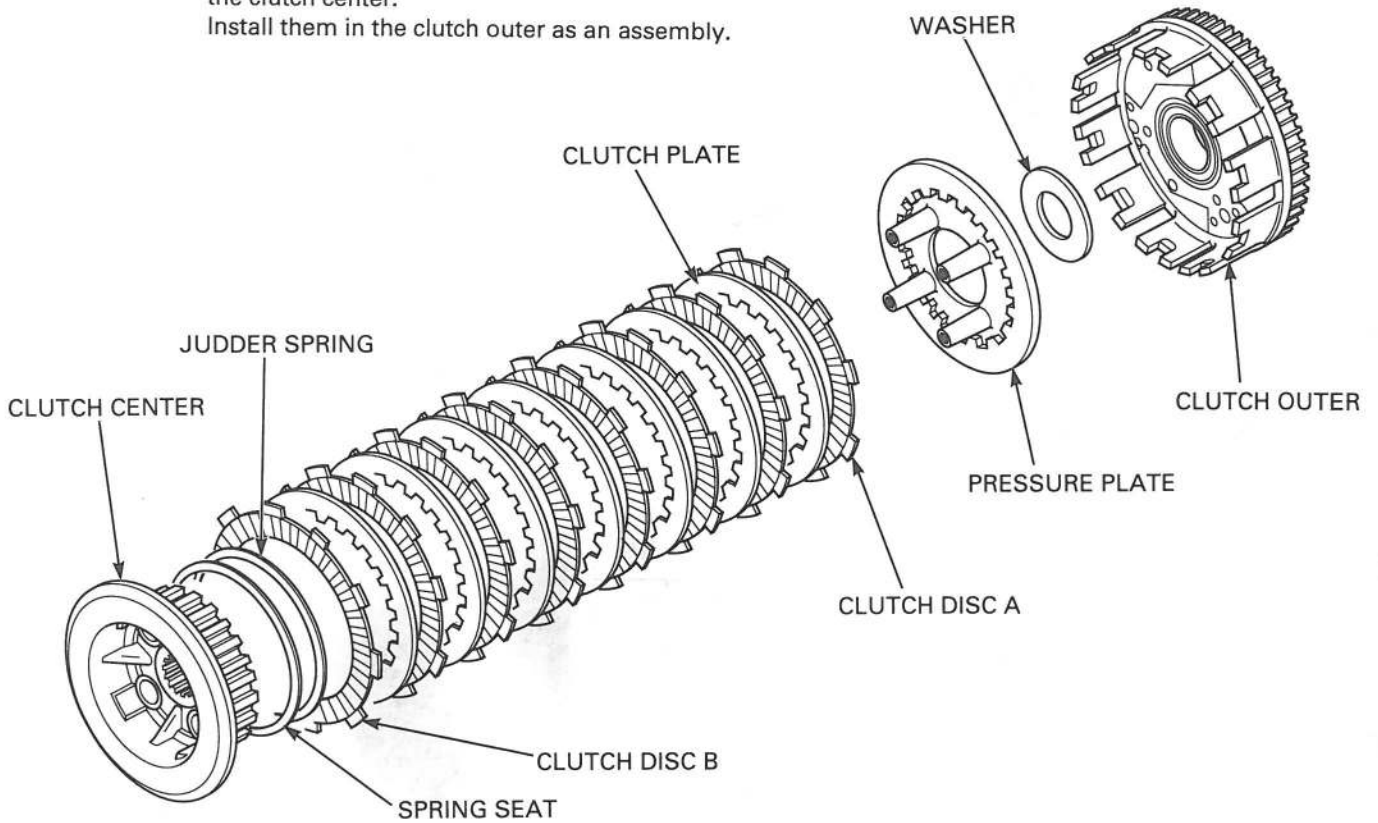

NOTE:

When installing the clutch disc B, align the end groove in the clutch outer with the tabs of disc.

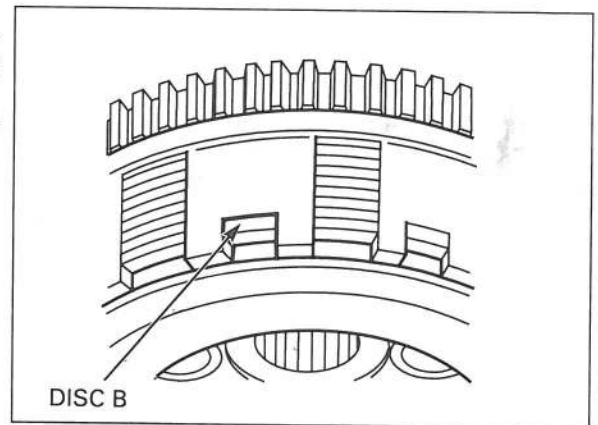

Install the clutch assembly to the mainshaft. Install the thrust washer. Install the new spring washer with its "OUT SIDE" mark facing out. Apply oil to the new clutch center lock nut threads. Install the lock nut.

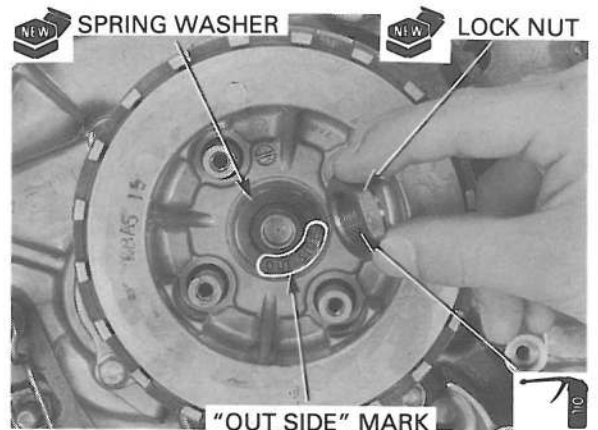

CLUTCH/GEARSHIFT LINKAGE

Hold the pressure plate with the clutch center holder and tighten the clutch center lock nut to the specified torque.

TOOL:

Clutch center holder



07JMB-MN50301 or
07HGB-001010B
07HGB-001010A and
07HGB-001020B or
07HGB-001020A
(U.S.A. only)

TORQUE: 128 N·m (13.0 kgf·m, 94 lbf·ft)

CLUTCH CENTER HOLDER

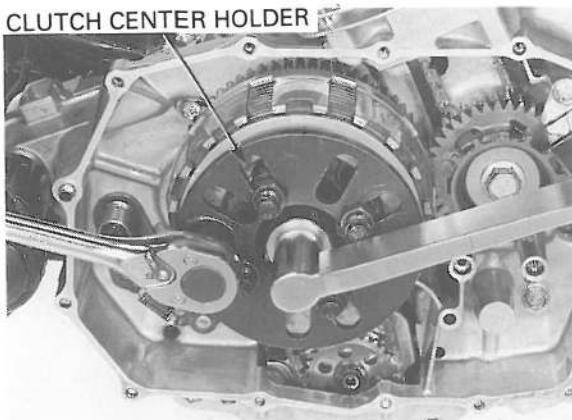

Remove the special tools and stake the lock nut into the mainshaft groove.

CAUTION:

Be careful not to damage the mainshaft threads.

LOCK NUT

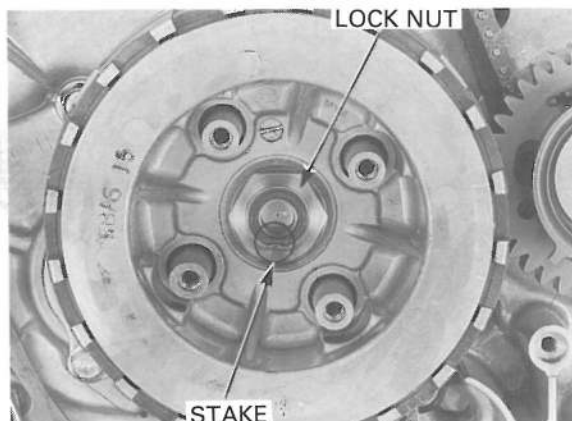

STAKE

Install the clutch springs and lifter plate/bearing. Install and tighten the clutch lifter plate bolts in a crisscross pattern in several steps.

TORQUE: 12 N·m (1.2 kgf·m, 9 lbf·ft)

LIFTER PLATE/BEARING

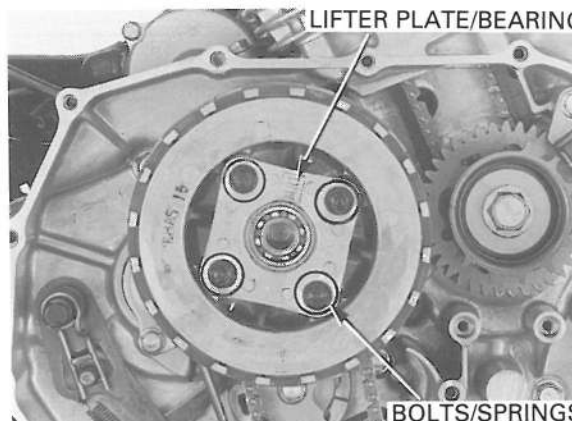

BOLTS/SPRINGS

If the oil pump driven sprocket is removed, tighten the driven sprocket bolt to the specified torque.

TORQUE: 15 N·m (1.5 kgf·m, 11 lbf·ft)

Install the right crankcase cover (see page 8-21).

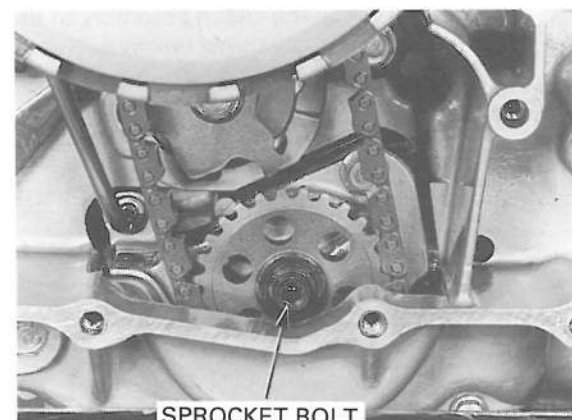

SPROCKET BOLT

RIGHT CRANKCASE COVER INSTALLATION

ASSEMBLY

Apply engine oil to the clutch lifter arm pivot needle bearings and dust seal lips.

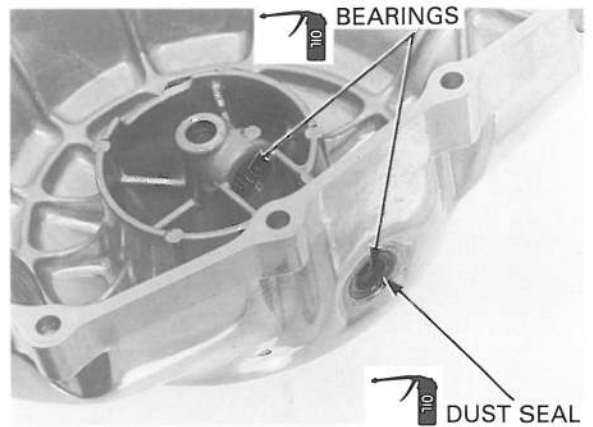

Apply engine oil to the clutch lifter arm sliding surfaces and slit.
Install the clutch lifter arm.

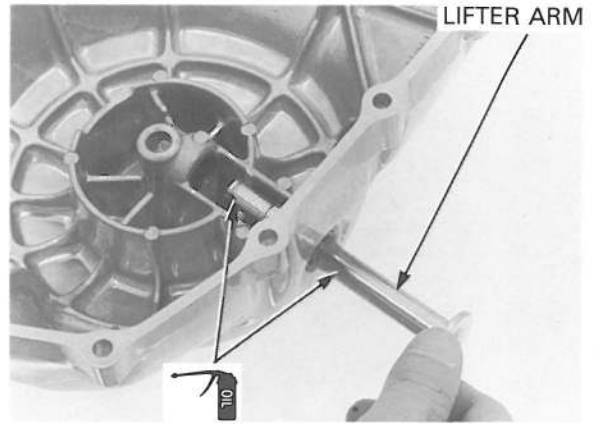

Install the return spring and snap ring.
Hook the spring end in the cover tab securely, and turn the shaft.

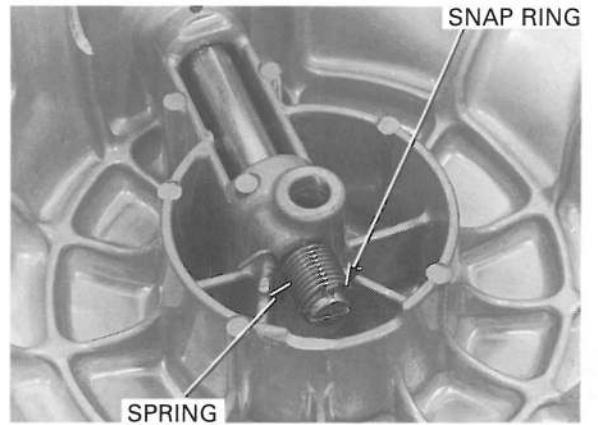

Apply engine oil to the clutch lifter piece.
Install the clutch lifter piece, aligning the piece end with the groove in the clutch lifter arm.

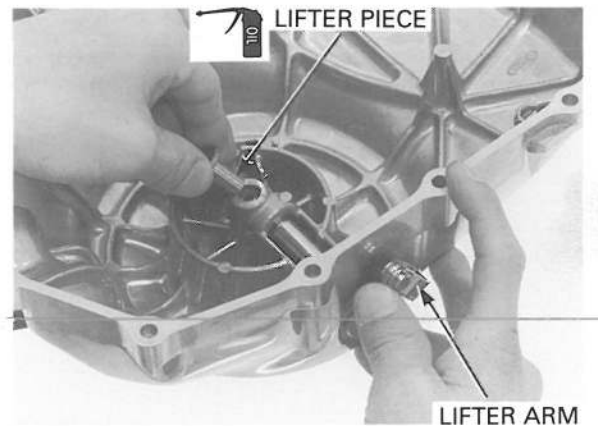

CLUTCH/GEARSHIFT LINKAGE

INSTALLATION

Install the dowel pins.

'98 – 2000: Install the new gasket.

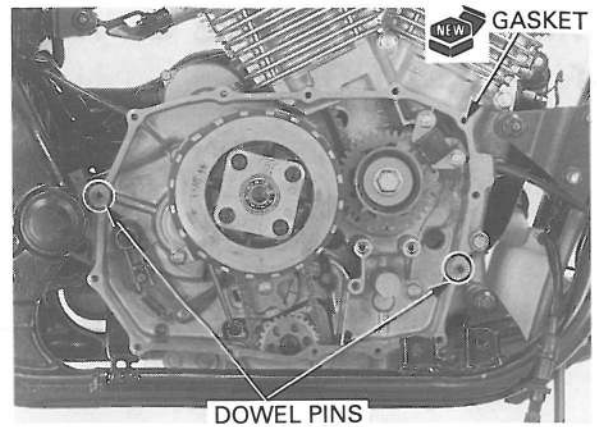

After 2000: Apply liquid sealant to the right crankcase cover mating surface.

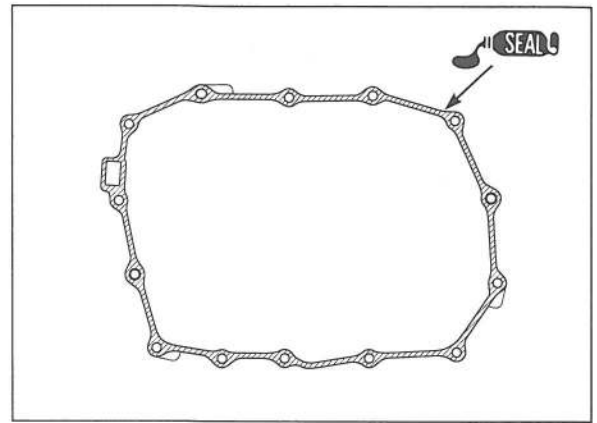

Install the right crankcase cover and clutch cable holder.

Install and tighten the right crankcase cover bolts in a crisscross pattern in several steps.

Install the rear brake pedal and left footpeg (page 14-16).

Install the exhaust pipe/muffler (page 2-8).

Fill the engine oil (page 3-12).

Perform the clutch adjustment (page 3-26).

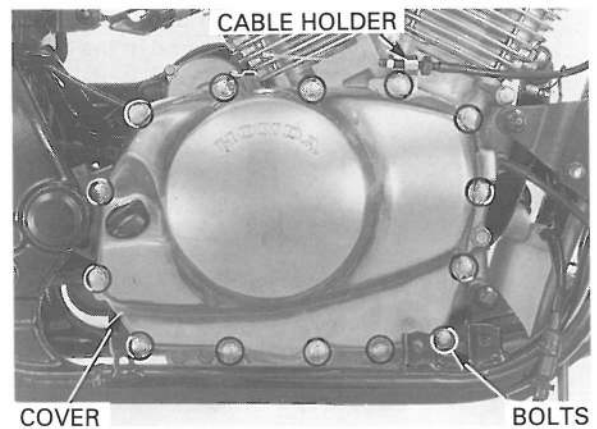

MEMO

ALTERNATOR/STARTER CLUTCH

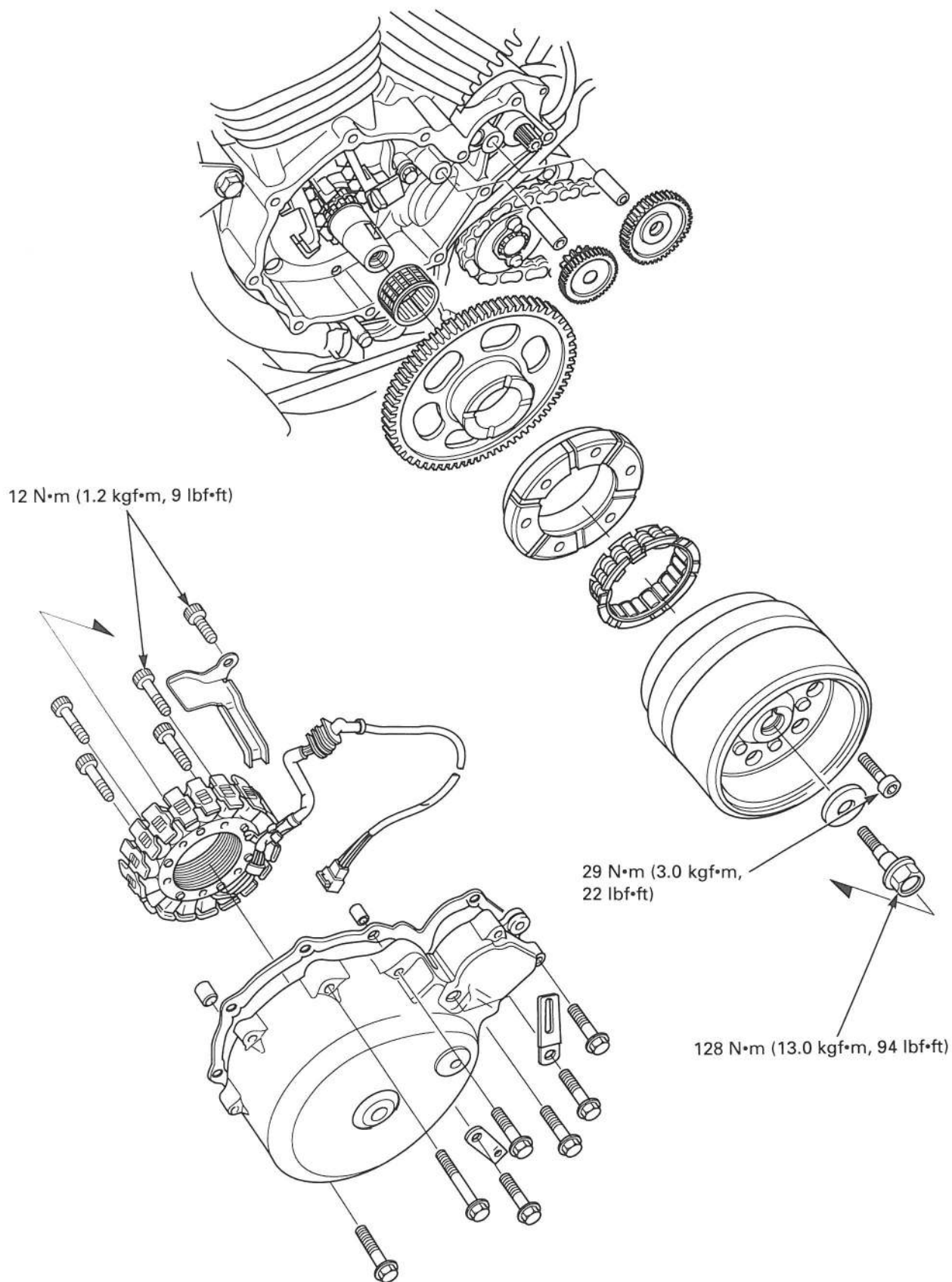

9. ALTERNATOR/STARTER CLUTCH

SERVICE INFORMATION	9-1	FLYWHEEL, STARTER CLUTCH	9-3
TROUBLESHOOTING	9-1	STATOR INSTALLATION	9-9
STATOR REMOVAL	9-2		

SERVICE INFORMATION

GENERAL

- The alternator and starter clutch maintenance can be done with the engine in the frame.
- Refer to section 16 for alternator inspection.

SPECIFICATIONS

Unit: mm (in)

ITEM		STANDARD	SERVICE LIMIT
Starter driven gear	I.D.	40.000 – 40.021 (1.5748 – 1.5756)	40.10 (1.579)
	O.D.	57.749 – 57.768 (2.2736 – 2.2743)	57.73 (2.273)
Starter clutch outer I.D.		74.414 – 74.440 (2.9297 – 2.9307)	74.46 (2.931)

TORQUE VALUES

Flywheel bolt	128 N•m (13.0 kgf•m, 94 lbf•ft)	Left hand threads Apply oil to the threads and seating surface
Starter one-way clutch housing bolt	29 N•m (3.0 kgf•m, 22 lbf•ft)	Apply a locking agent to the threads
Stator mounting socket bolt	12 N•m (1.2 kgf•m, 9 lbf•ft)	Apply a locking agent to the threads
Stator wire holder socket bolt	12 N•m (1.2 kgf•m, 9 lbf•ft)	Apply a locking agent to the threads

TOOLS

Flywheel holder	07725 – 0040000 or equivalent commercially available in U.S.A.
Rotor puller	07733 – 0020001 or 07933-3280001

TROUBLESHOOTING

Starter motor turns, but engine does not turn

- Faulty starter clutch
- Damaged reduction gear
- Damaged starter idle gear

STATOR REMOVAL

Refer to page 16-7 for alternator (charging coil) inspection.

Remove the right side cover and disconnect the alternator 3P (White) connector.

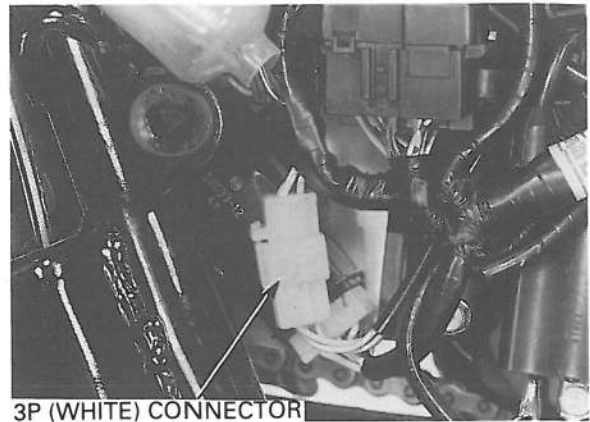

3P (WHITE) CONNECTOR

Remove the left footpeg and gearshift pedal (page 8-12).

Remove the left rear cover (page 7-3).

Place a container under the left crankcase cover to catch the engine oil.

Loosen the left crankcase cover bolts in a crisscross pattern in several steps.

Remove the eleven left crankcase cover bolts and cover.

CAUTION:

The left crankcase cover (stator) is magnetically attached to the flywheel, be careful during removal.

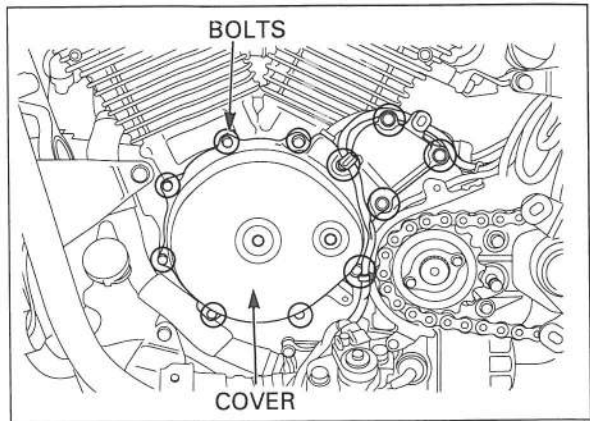

Remove the gasket and dowel pins.

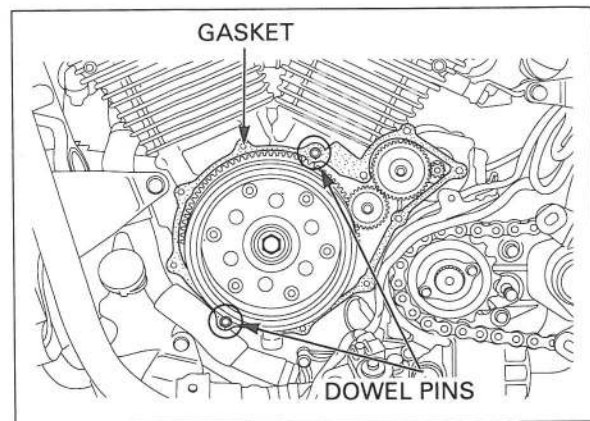

Remove the socket bolts and stator wire holder from the left crankcase cover.

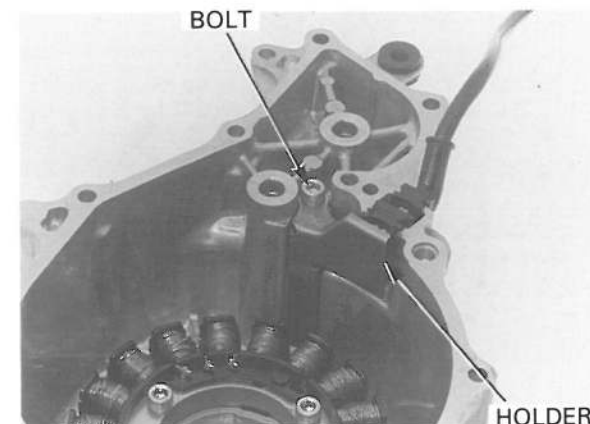

HOLDER

Remove the stator grommets from the left crankcase cover.

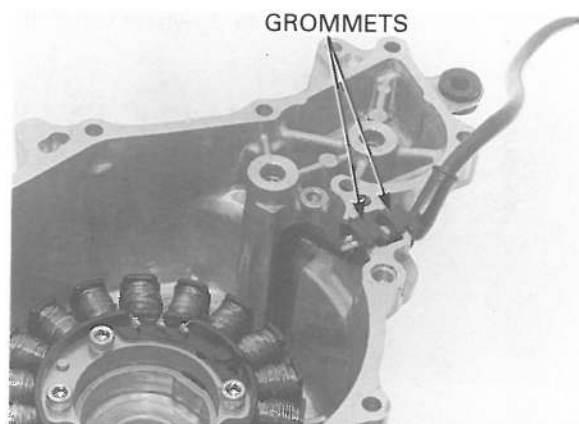

Remove the socket bolts and stator from the left crankcase cover.

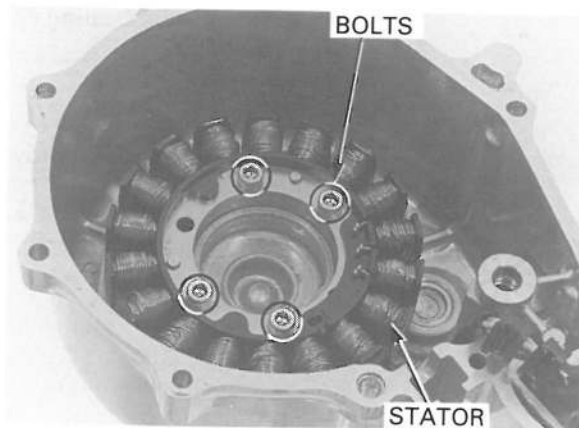

FLYWHEEL, STARTER CLUTCH

FLYWHEEL REMOVAL

Remove the left crankcase cover (page 9-2).

Remove the starter idle gear and shaft.
Remove the starter reduction gear and shaft.

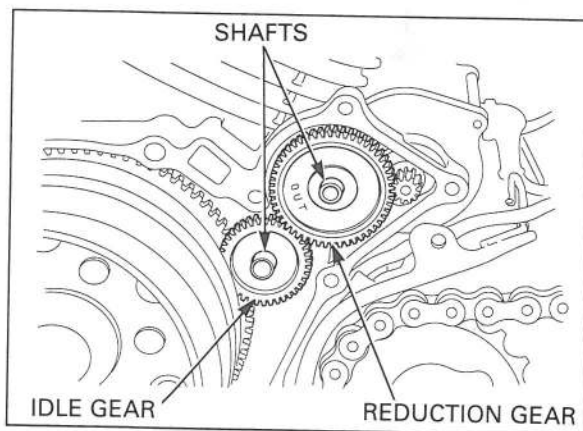

CAUTION:

The flywheel bolt has left hand threads.

Remove the flywheel bolt and washer while holding the flywheel with a flywheel holder.

TOOL:

Flywheel holder

07725-0040000 or
equivalent commercially
available in U.S.A.

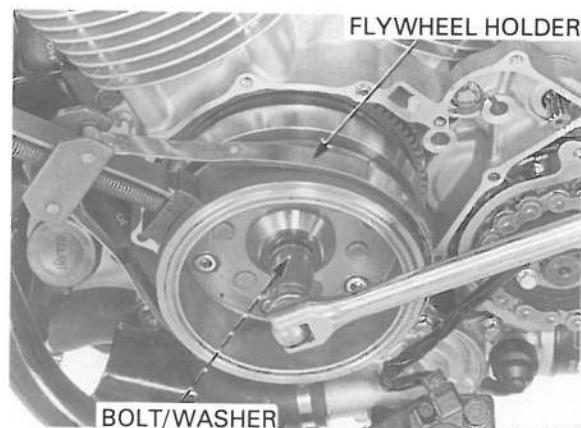

ALTERNATOR/STARTER CLUTCH

Remove the flywheel using the rotor puller.

TOOL:

Rotor puller

07733-0020001 or
07933-3280001

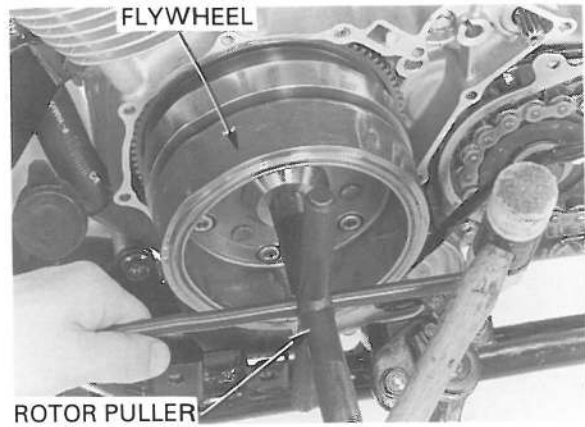

Remove the needle bearing and woodruff key from the crankshaft.

NOTE:

- When woodruff key removal, be careful not to damage the key groove or crankshaft.
- Do not loose the woodruff key.

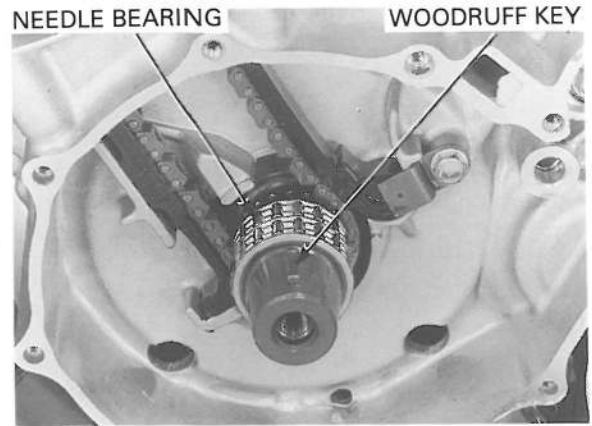

STARTER DRIVEN GEAR, STARTER CLUTCH REMOVAL

Check that the driven gear turns smoothly in one direction and locks up in the other direction.

Remove the starter driven gear from the flywheel while turning the driven gear counterclockwise.

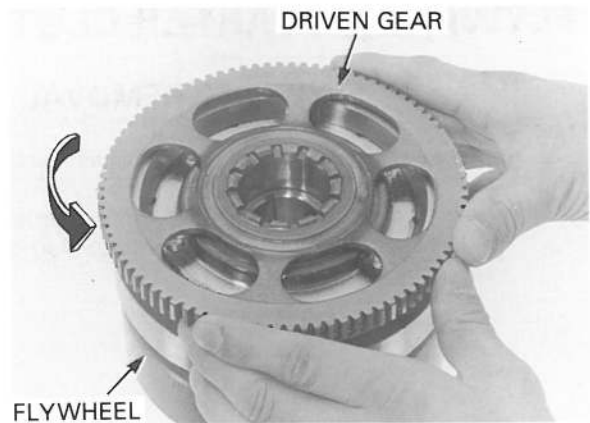

Do not remove the clutch housing and one-way clutch unless it is necessary to inspect them.

Remove the starter one-way clutch torx bolts while holding the flywheel with a flywheel holder.

TOOL:

Flywheel holder

07725-0040000 or
equivalent commercially
available in U.S.A.

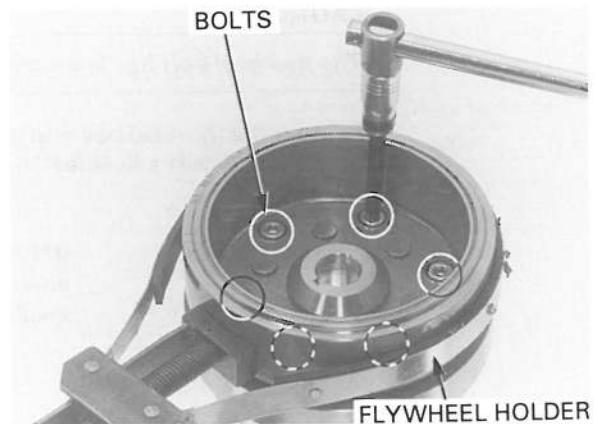

Remove the clutch housing and one-way clutch from the flywheel.

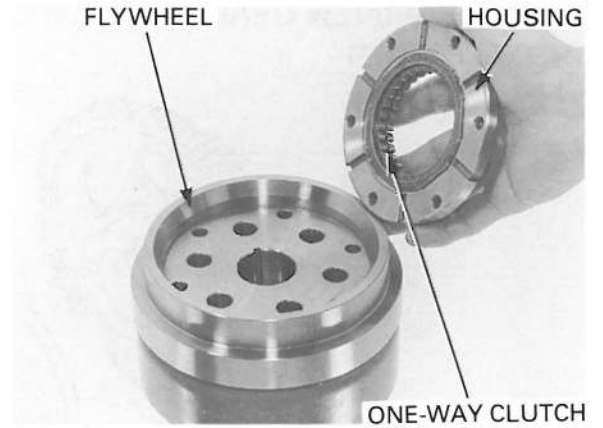

STARTER CLUTCH INSPECTION

NEEDLE BEARING

Check the needle bearing clutch sprag for abnormal wear, damage.

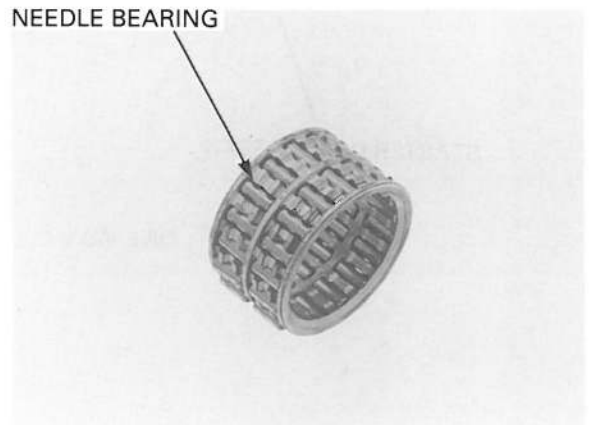

ONE-WAY CLUTCH

Check the one-way clutch sprag for abnormal wear, damage or irregular movement.

NOTE:

- Do not remove the one-way clutch from the clutch housing, unless it is necessary to replace with a new one.
- If removed the spring from the one-way clutch groove, replace the one-way clutch assembly (clutch and spring) with a new one.

CLUTCH HOUSING

Check the clutch inner contact surface of the housing for damage.

STARTER DRIVEN GEAR

Check the roller contact surface for damage.

Measure the driven gear O.D.

SERVICE LIMIT: 57.73 mm (2.273 in)

Measure the driven gear I.D.

SERVICE LIMIT: 40.10 mm (1.579 in)

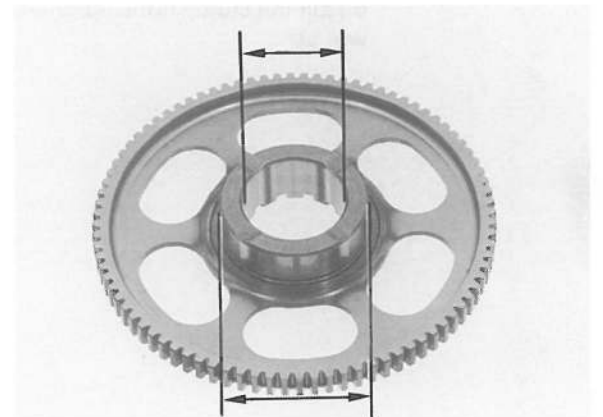
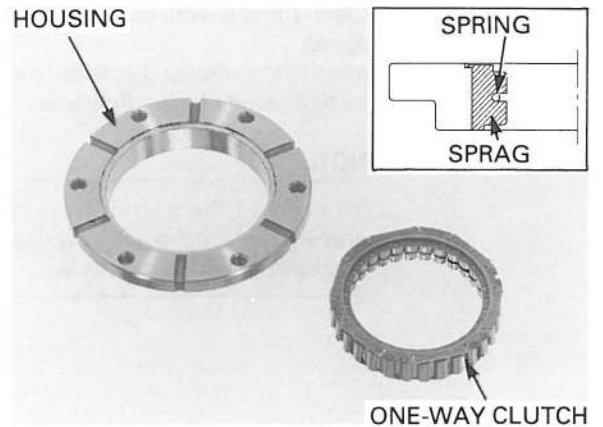

ALTERNATOR/STARTER CLUTCH

STARTER DRIVEN GEAR, STARTER CLUTCH INSTALLATION

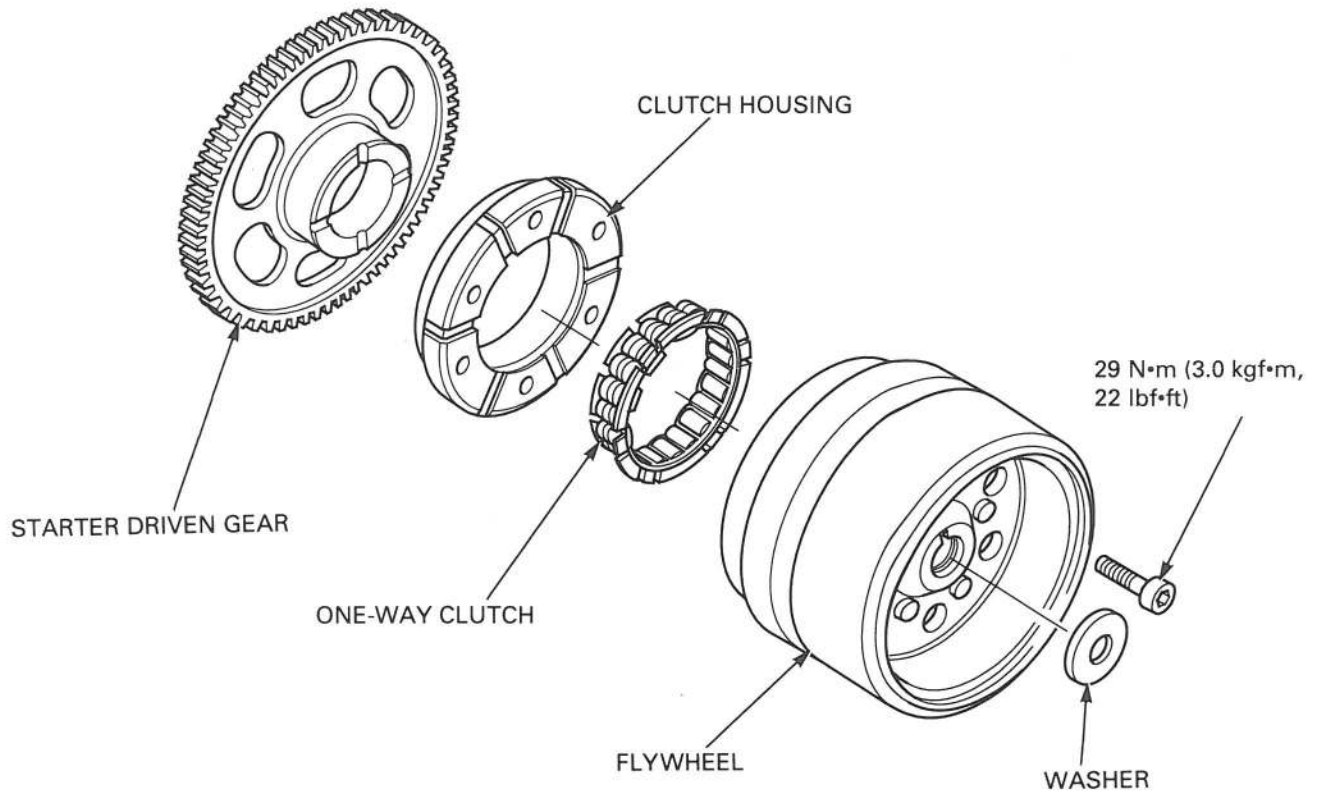

Clean the one-way clutch and apply engine oil to the sprag.
Install the one-way clutch into the clutch housing with its flange side facing flywheel.

NOTE:

If removed the spring from the one-way clutch groove, replace the one-way clutch assembly (clutch and spring) with a new one.

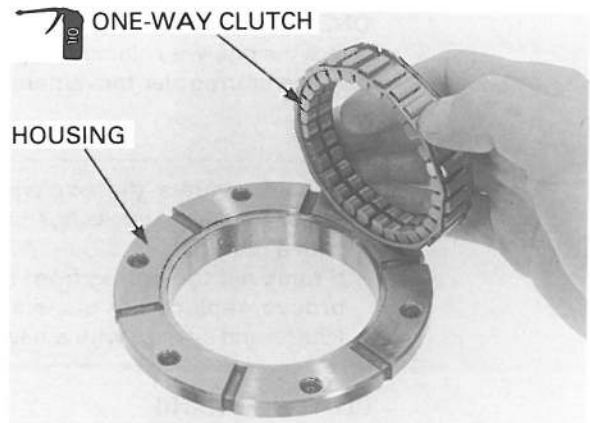

Install the clutch housing/one-way clutch to the flywheel.

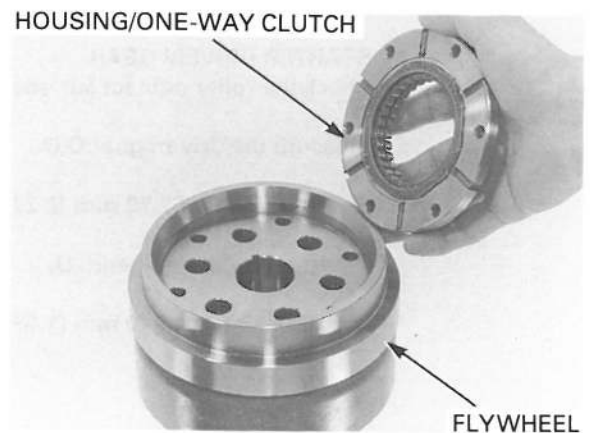

Hold the flywheel using the flywheel holder.

TOOL:
Flywheel holder **07925-0040000 or equivalent commercially available in U.S.A.**

Clean and apply a locking agent to the starter one-way clutch torx bolt threads.
Install and tighten the starter one-way clutch torx bolts to the specified torque.

TORQUE: 29 N·m (3.0 kgf·m, 22 lbf·ft)

Install the starter driven gear to the flywheel while turning the driven gear counterclockwise.

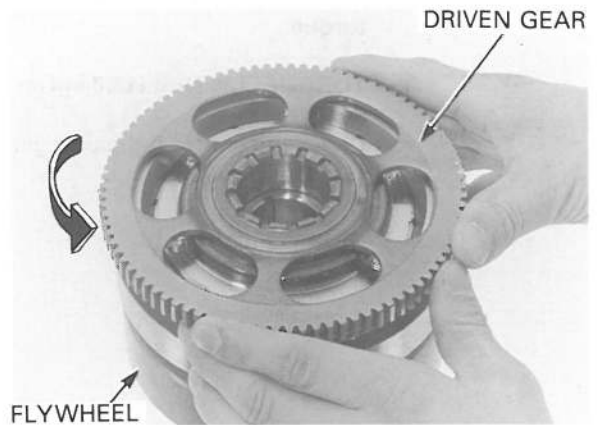
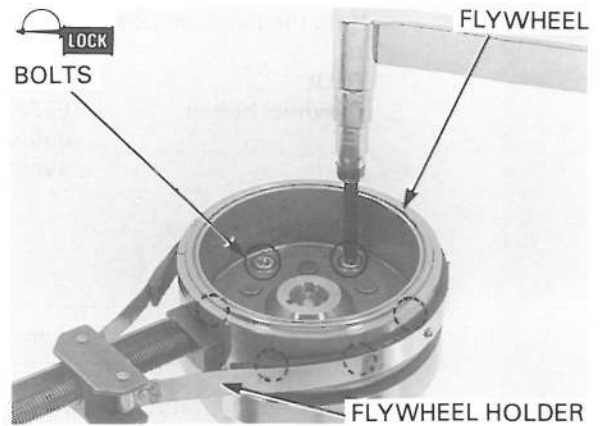

FLYWHEEL INSTALLATION

During woodruff key installation, be careful not to damage the key groove or crankshaft. Apply engine oil to the needle bearing and install it to the crankshaft.
Wipe any oil off the mating surface of the crankshaft.
Install the woodruff key to the key groove of crankshaft.

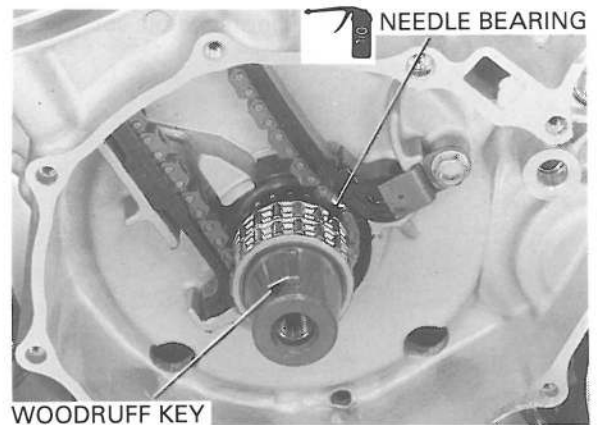

Wipe any oil off the mating surface of the flywheel.
Install the flywheel to the crankshaft aligning the key groove of the flywheel with the woodruff key on the crankshaft.

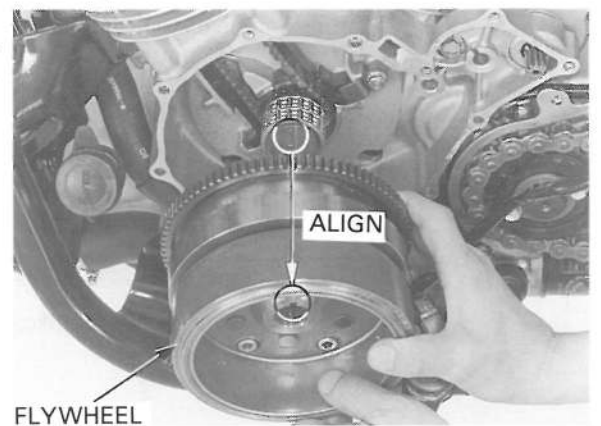

ALTERNATOR/STARTER CLUTCH

Hold the flywheel using the flywheel holder.

TOOL:

Flywheel holder **07725-0040000 or equivalent commercially available in U.S.A.**

Install the washer.

CAUTION:

The flywheel bolt has left hand threads.

Apply engine oil to the flywheel bolt threads and seating surface.

Install and tighten the flywheel bolt to the specified torque.

TORQUE: 128 N·m (13.0 kgf·m, 94 lbf·ft)

Check the starter reduction gear, shaft and journal for wear or damage.

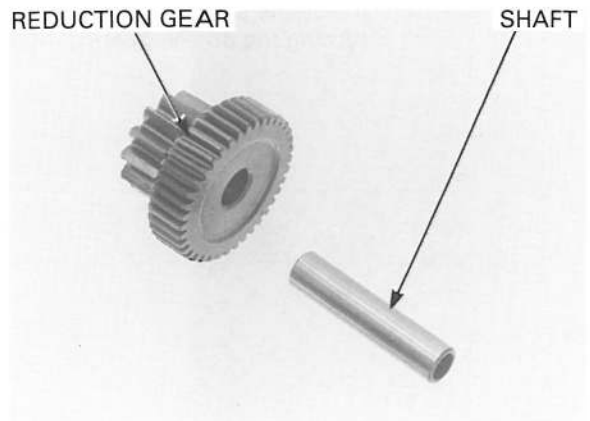
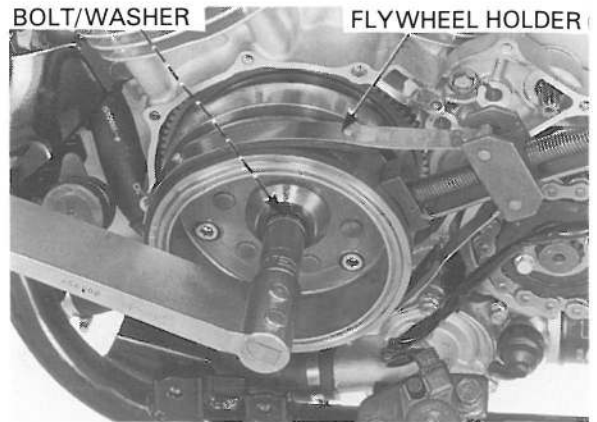

Check the starter idle gear, shaft and journal for wear or damage.

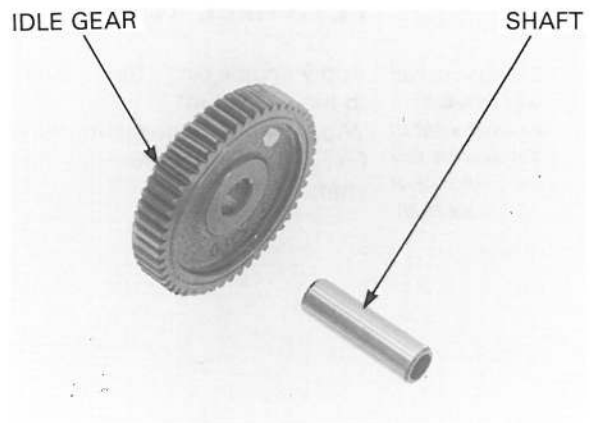

Apply engine oil to the starter reduction gear, starter idle gear and shafts.

Install the starter reduction gear, starter idle gear and shafts to the left crankcase as assembly.

NOTE:

Install the starter drive gear with its "OUT" mark facing out.

Install the stator and left crankcase cover (page 9-10).

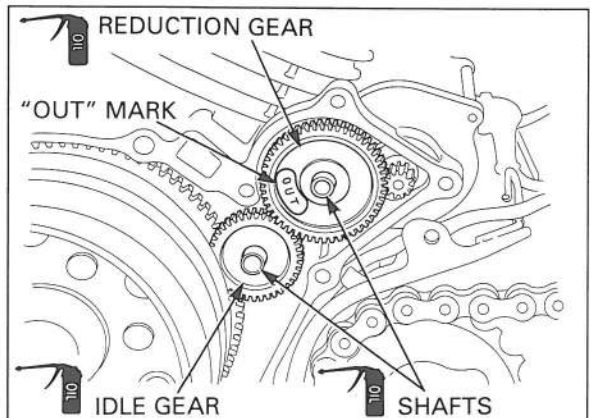

STATOR INSTALLATION

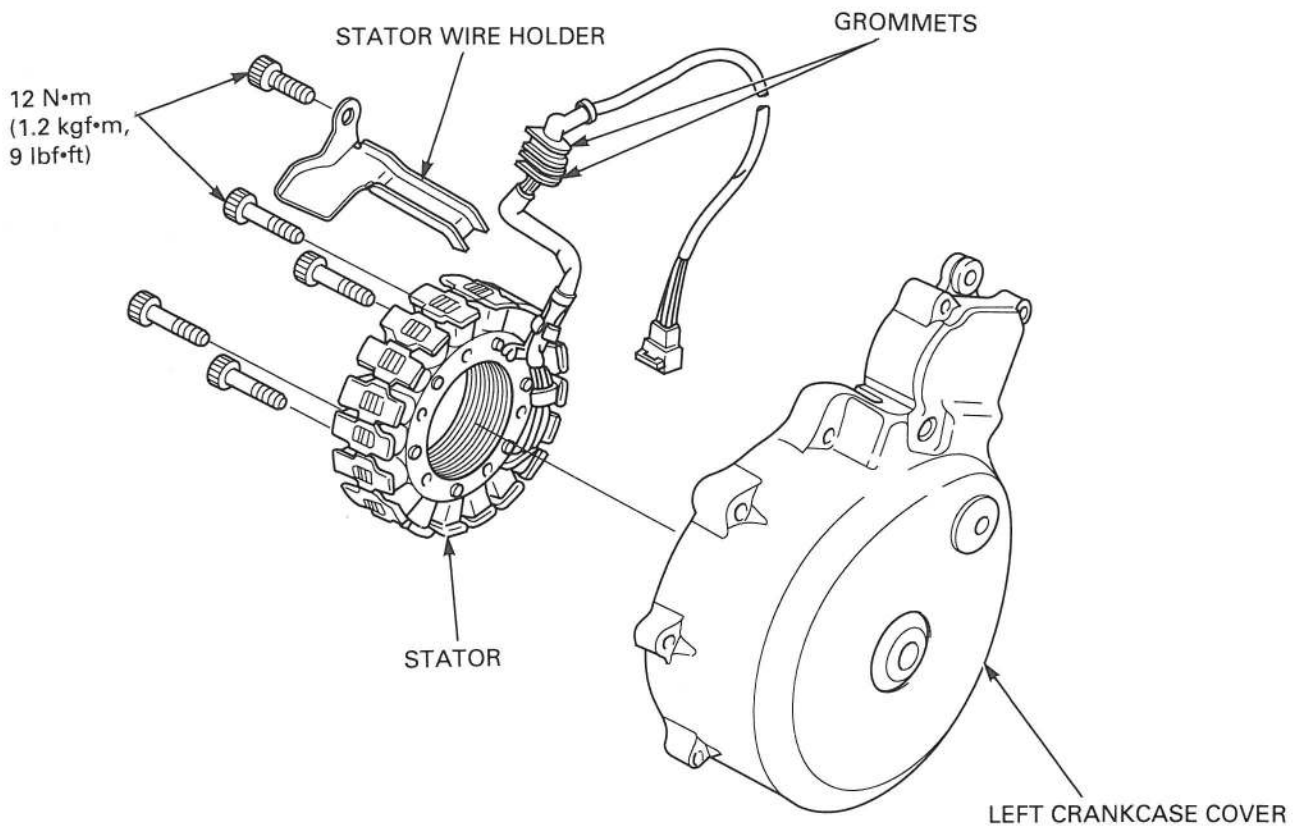

Install the stator to the left crankcase cover.
Clean and apply a locking agent to the stator mounting socket bolt threads.
Install and tighten the stator socket bolts to the specified torque.

TORQUE: 12 N·m (1.2 kgf·m, 9 lbf·ft)

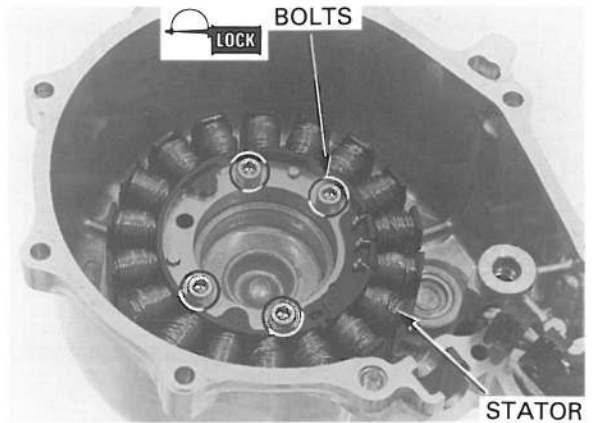

Clean and apply sealant to the wire grommets seating surface and install the grommets into the grooves in the left crankcase cover.

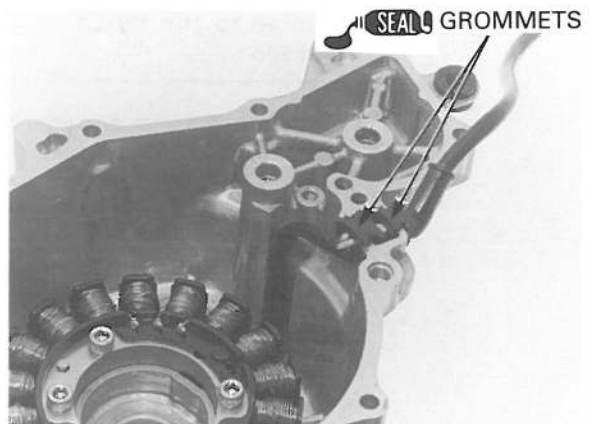

ALTERNATOR/STARTER CLUTCH

Clean and apply a locking agent to the wire holder socket bolt threads.
Install the stator wire holder to the left crankcase cover as shown.
Install and tighten the socket bolt to the specified torque.

TORQUE: 12 N·m (1.2 kgf·m, 9 lbf·ft)

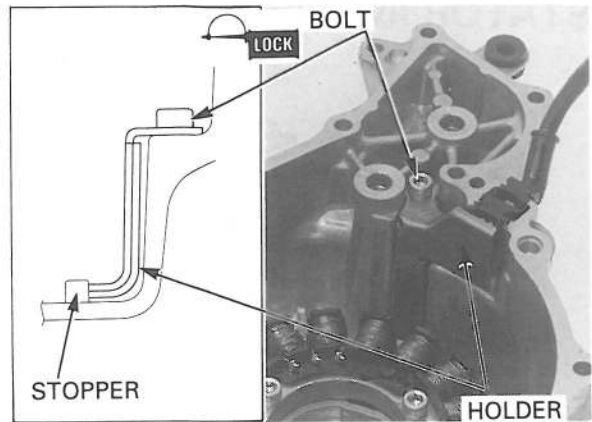

Install the dowel pins.

'98 - 2000: Install the new gasket.

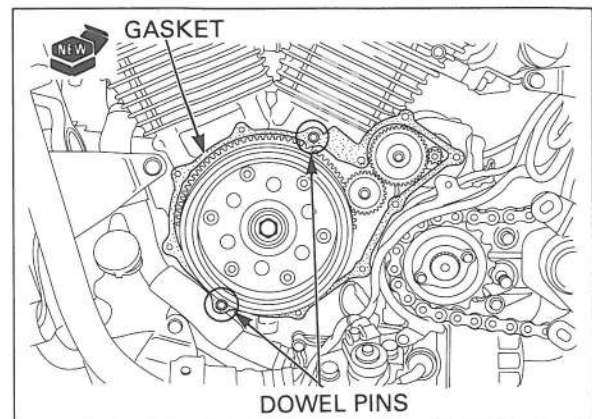

After 2000: Apply liquid sealant to the left crankcase cover mating surface.

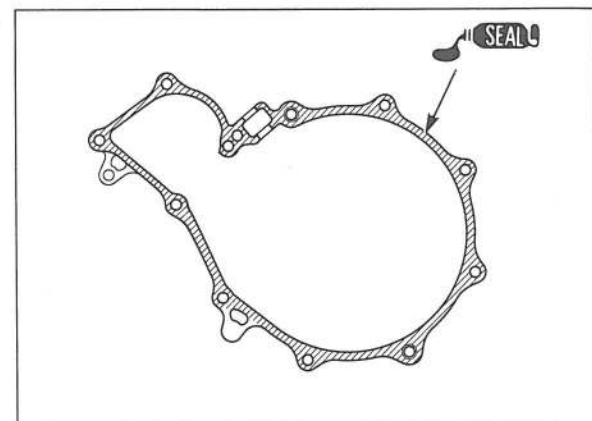

Install the left crankcase cover.

NOTE:

The left crankcase cover (stator) is magnetically attached to the flywheel, be careful during installation.

Clean and apply a locking agent to the left crankcase cover bolt threads as shown.
Install and tighten the left crankcase cover bolts to the specified torque in a crisscross pattern in several steps.

TORQUE: 12 N·m (1.2 kgf·m, 9 lbf·ft)

NOTE:

Route the wire harness properly (page 1-20).

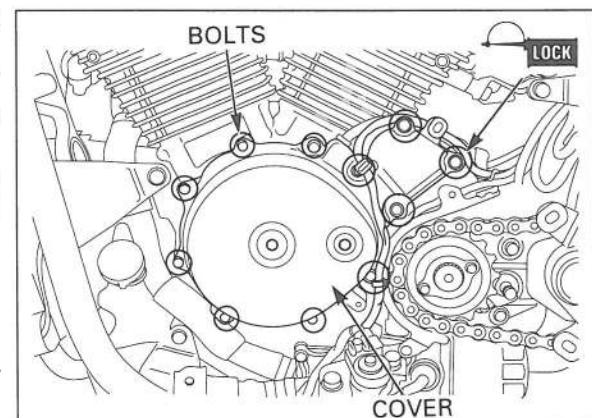

Connect the alternator 3P (White) connector.

Install the following:

- Left rear cover (page 7-14)
- Gearshift pedal and left footpeg (page 8-16)
- Left side cover. (page 2-4)

Check the engine oil level (page 3-11).



3P (WHITE) CONNECTOR

CYLINDER HEAD/VALVES

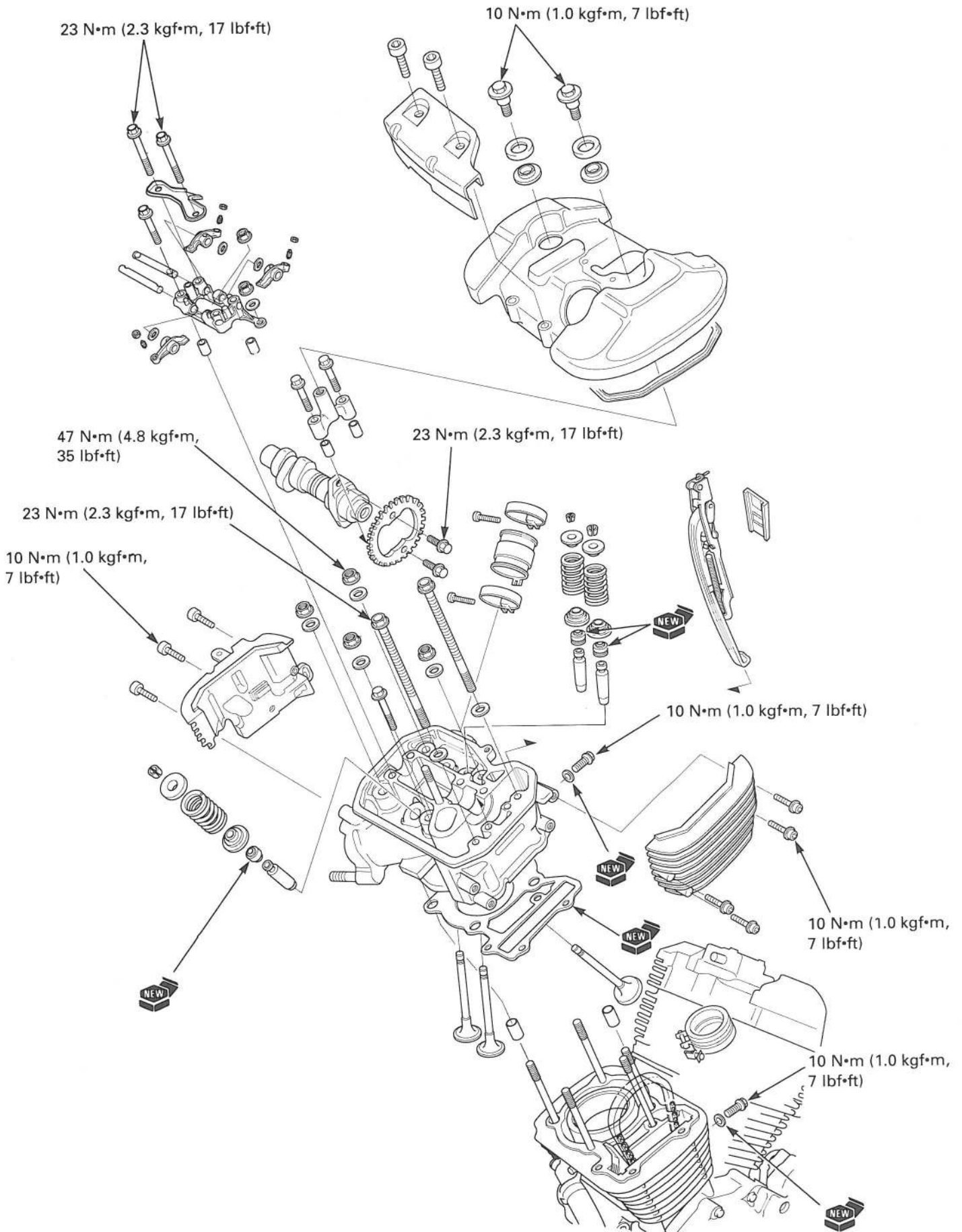

10. CYLINDER HEAD/VALVES

SERVICE INFORMATION	10-1	VALVE GUIDE REPLACEMENT	10-18
TROUBLESHOOTING	10-3	VALVE SEAT INSPECTION/ REFACING	10-20
CYLINDER COMPRESSION	10-4	CYLINDER HEAD ASSEMBLY	10-22
CYLINDER HEAD COVER REMOVAL	10-5	CYLINDER HEAD INSTALLATION	10-24
CAMSHAFT REMOVAL	10-8	CAMSHAFT INSTALLATION	10-26
CYLINDER HEAD REMOVAL	10-14	CYLINDER HEAD COVER INSTALLATION	10-32
CYLINDER HEAD DISASSEMBLY	10-15		

SERVICE INFORMATION

GENERAL

- The engine must be removed from the frame before servicing the rear cylinder head.
- The front and rear cylinder head cover and front cylinder head can be serviced with the engine in the frame.
- The camshaft can be serviced with the engine in the frame.
- Be careful not to damage the mating surface when removing the cylinder head cover and cylinder head.
- When disassembling, mark and store the disassembled parts to ensure that they are reinstalled in their original locations.
- Clean all disassembled parts with clean solvent and dry them using compressed air before inspection.
- During assembly apply molybdenum disulfide oil to the camshaft holders, camshaft journals of the cylinder head, rocker arm shafts, rocker arm slipper faces and valve stems to provide initial lubrication.

10

SPECIFICATIONS

Unit: mm (in)

ITEM		STANDARD	SERVICE LIMIT	
Cylinder compression		1,275 ± 98 kPa (13.0 ± 1.0 kgf/cm ² , 185 ± 14 psi) at 400 rpm	—	
Cylinder head warpage		—	0.10 (0.004)	
Valve, valve guide	Valve clearance	IN	0.13 – 0.17 (0.005 – 0.007)	
		EX	0.18 – 0.22 (0.007 – 0.009)	
	Valve stem O.D.	IN	5.475 – 5.490 (0.2156 – 0.2161)	5.45 (0.215)
		EX	6.555 – 6.570 (0.2580 – 0.2587)	6.55 (0.258)
	Valve guide I.D.	IN	5.500 – 5.512 (0.2165 – 0.2170)	5.56 (0.219)
		EX	6.600 – 6.615 (0.2598 – 0.2604)	6.65 (0.262)
	Stem-to-guide clearance	IN	0.010 – 0.037 (0.0004 – 0.0015)	0.10 (0.004)
		EX	0.030 – 0.060 (0.0012 – 0.0024)	0.11 (0.004)
	Valve guide projection above cylinder head	IN	19.5 (0.77)	—
		EX	18.0 (0.71)	—
Valve seat width	IN/EX	0.90– 1.10 (0.035 – 0.043)	1.5 (0.06)	
Valve spring free length	IN	42.14 (1.659)	40.58 (1.598)	
	EX	42.83 (1.686)	41.25 (1.624)	

CYLINDER HEAD/VALVES

Unit: mm (in)

(Cont'd)		ITEM		STANDARD	SERVICE LIMIT
Camshaft	Came lobe height	IN		38.381 (1.5111)	38.10 (1.500)
		EX		38.407 (1.5121)	38.20 (1.504)
	Journal O.D.			21.959 – 21.980 (0.8645 – 0.8654)	21.90 (0.862)
	Runout			0.030 (0.012)	0.05 (0.002)
	Oil clearance			0.050 – 0.111 (0.0020 – 0.0044)	0.13 (0.005)
	Identification marks			"F": Front, "R": Rear	—
Rocker arm I.D.		IN/EX		12.000 – 12.018 (0.4724 – 0.4731)	12.05 (0.474)
Rocker arm shaft O.D.		IN/EX		11.966 – 11.984 (0.4711 – 0.4718)	11.83 (0.466)
Rocker arm-to-rocker arm shaft clearance				0.016 – 0.052 (0.0006 – 0.0020)	0.07 (0.003)

TORQUE VALUES

Air cleaner housing stay mounting bolt	13 N•m (1.3 kgf•m, 9 lbf•ft)	
EVAP air injection reed valve cover bolt	5 N•m (0.5 kgf•m, 3.6 lbf•ft)	
Cylinder head cover bolt	10 N•m (1.0 kgf•m, 7 lbf•ft)	
Cam sprocket bolt	23 N•m (2.3 kgf•m, 17 lbf•ft)	Apply a locking agent to the threads
Cam shaft end holder bolt	10 N•m (1.0 kgf•m, 7 lbf•ft)	
Cam shaft holder 8 mm bolt	23 N•m (2.3 kgf•m, 17 lbf•ft)	
8 mm nut	23 N•m (2.3 kgf•m, 17 lbf•ft)	
Cam chain tensioner mounting bolt	10 N•m (1.0 kgf•m, 7 lbf•ft)	
Cylinder head 6 mm bolt	12 N•m (1.2 kgf•m, 9 lbf•ft)	Apply oil to the threads and seating surface
8 mm bolt	23 N•m (2.3 kgf•m, 17 lbf•ft)	Apply oil to the threads and seating surface
8 mm nut	23 N•m (2.3 kgf•m, 17 lbf•ft)	Apply oil to the seating surface
10 mm nut	47 N•m (4.8 kgf•m, 35 lbf•ft)	Apply oil to the seating surface
Cylinder head fin socket bolt	10 N•m (1.0 kgf•m, 7 lbf•ft)	
Crankcase breather case cover bolt	12 N•m (1.2 kgf•m, 9 lbf•ft)	ALOC bolt: replace with a new one

TOOLS

Valve guide driver, 5.5 mm	07742-0010100	
Valve guide driver, 6.6 mm	07742-0010200	
Valve guide driver	07743-0020000	Not available in U.S.A.
Valve spring compressor	07757-0010000	
Valve seat cutter		
– Seat cutter IN 27.5 mm (45°)	07780-0010200	Equivalent commercially available in U.S.A.
EX 35 mm (45°)	07780-0010400	
– Flat cutter IN 28 mm (32°)	07780-0012100	
EX 35 mm (32°)	07780-0012300	
– Interior cutter IN 30 mm (60°)	07780-0014000	
EX 37.5 mm (60°)	07780-0014100	
– Cutter holder 5.5 mm (IN)	07781-0010101	
6.6 mm (EX)	07781-0010201	
Valve guide reamer, 5.510 mm (IN)	07984-2000001	or 07984-200000D (U.S.A. only)
Valve guide reamer, 6.612 mm (EX)	07984-ZE20001	or 07984-ZE2000D (U.S.A. only)

TROUBLESHOOTING

- Engine top-end problems usually affect engine performance. These can be diagnosed by a compression test, or by tracking noises to the top-end
- If performance is poor at low speeds, check for white smoke in the crankcase breather tube. If the tube is smoky, check for a seized piston ring.

Compression too low, hard starting or poor performance at low speed

- Valves
 - Incorrect valve adjustment
 - Burned or bent valves
 - Incorrect valve timing
 - Broken valve spring
 - Uneven valve seating
- Cylinder head
 - Leaking or damaged cylinder head gasket
 - Warped or cracked cylinder head
- Loose spark plug
- Faulty cylinder, piston (Section 11)

Compression too high

- Excessive carbon build-up in cylinder head or on top of piston

Excessive smoke

- Worn valve stem or valve guide
- Damaged stem seal
- Faulty cylinder, piston (Section 11)

Excessive noise

- Incorrect valve adjustment
- Sticking valve or broken valve spring
- Damaged or worn camshaft
- Loose or worn cam chain
- Worn or damaged cam chain tensioner
- Worn cam sprocket teeth
- Faulty cylinder, piston (Section 11)

Rough idle

- Low cylinder compression

CYLINDER COMPRESSION

⚠ WARNING

If the engine must be running to do some work, make sure the area is well-ventilated. Never run the engine in an enclosed area.

Warm up the engine to normal operating temperature.

To measure the cylinder compression of each cylinder, remove only one plug at a time.

Stop the engine, disconnect the spark plug caps and remove one spark plug cap at a time.

Shift the transmission into neutral.

Front cylinder compression as following:

– Remove the air cleaner housing (page 5-4).

Rear cylinder compression as following:

– Remove the rear cylinder head left side fin (page 10-7).

Install the compression gauge attachment in a spark plug hole.

Connect the compression gauge to the attachment. Open the throttle all the way and crank the engine with the starter motor.

NOTE:

Crank the engine until the gauge reading stops rising. The maximum reading is usually reached within 4-7 seconds.

STANDARD: 1,275 ± 98 kPa (13.0 ± 1.0 kgf/cm², 185 ± 14 psi) at 400 rpm

If compression is high, it indicates that carbon deposits have accumulated on the combustion chamber and/or the piston crown.

If compression is low, pour 3 - 5 cc (0.1 - 0.2 oz) of clean engine oil into the cylinder through the spark plug hole and recheck the compression.

If the compression increases from the previous value, check the cylinder, piston and piston rings.

- Leaking cylinder head gasket
- Worn piston ring
- Worn cylinder and piston

If compression is the same as the previous value, check the values for leakage.

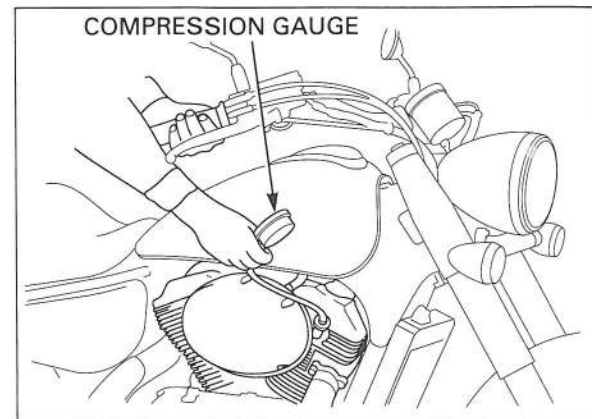
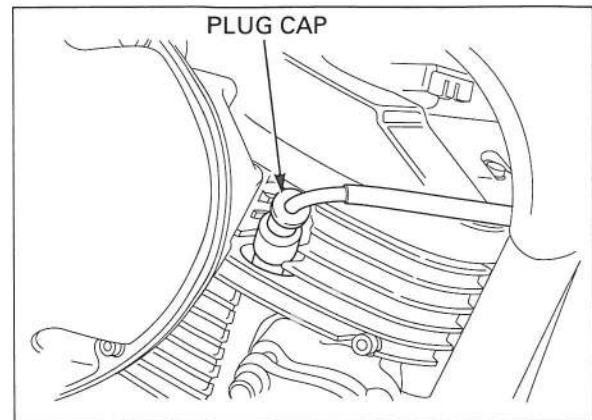

CYLINDER HEAD COVER REMOVAL

FRONT

Drain the coolant (page 6-5).

Remove the following:

- Steering covers (page 2-3)
- Fuel tank (page 2-4)
- Air cleaner housing (page 5-4)
- Air cleaner chamber (page 5-6)
- Carburetors (page 5-8)

Disconnect the spark plug caps.

Remove the bolt and sub-air cleaner housing.

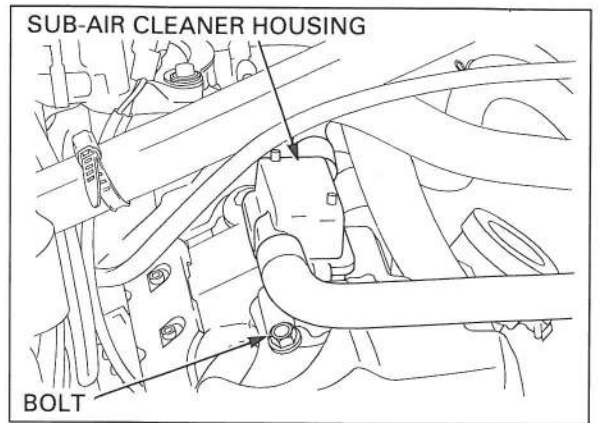
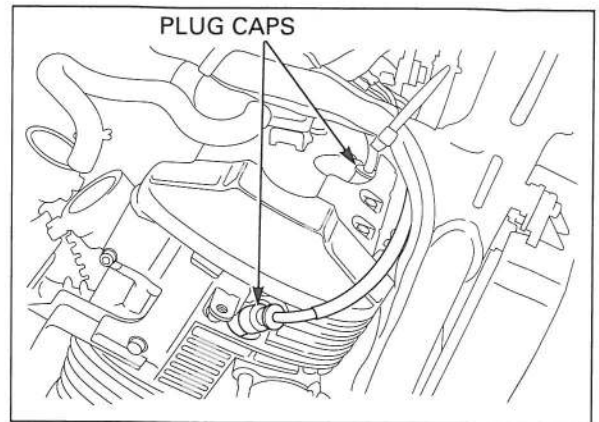

Remove the bolts and cylinder head cover outer cover.

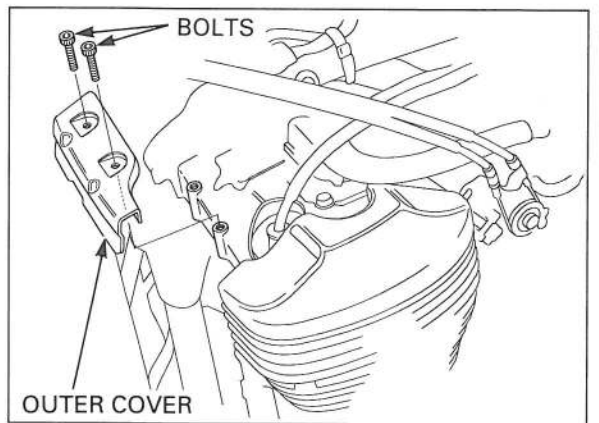

Remove the socket bolts and each side cylinder fins.

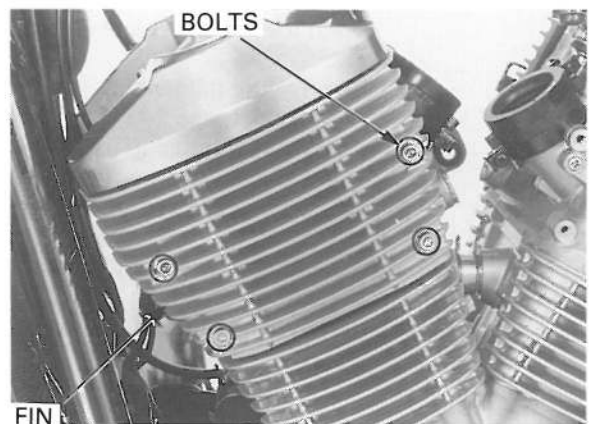

CYLINDER HEAD/VALVES

Remove the thermostat housing mounting bolt and move the thermostat housing to upward.

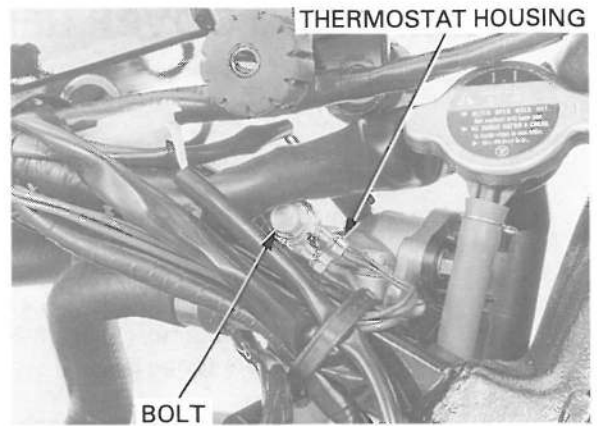

Remove the cylinder head cover bolts, washers and rubber seals.



Be careful not to damage the wire harness and mating surfaces when removing the cylinder head cover.

Remove the cylinder head cover and gasket.

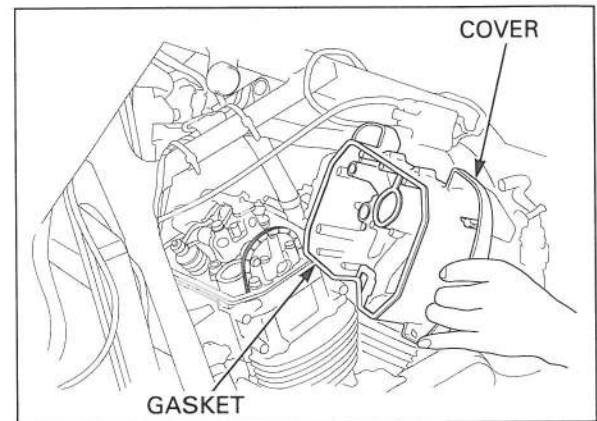

REAR

Drain the coolant (page 6-6).

Remove the following:

- Fuel tank (page 2-4)
- Air cleaner housing (page 5-4)
- Air cleaner chamber (page 5-6)
- Carburetors (page 5-8)

Disconnect the spark plug cap.

Remove the bolts and breather cover.

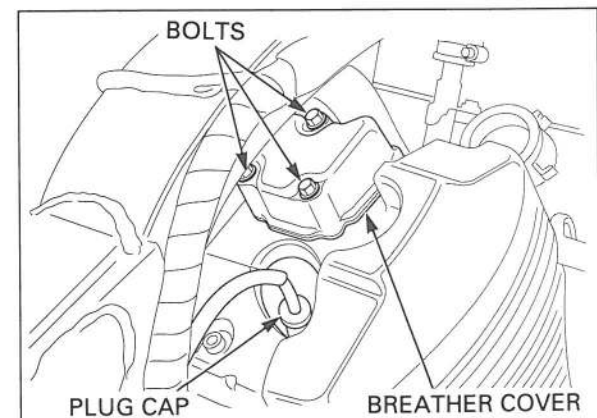

CYLINDER HEAD/VALVES

Remove the bolts, cable guide and cylinder head cover outer cover.

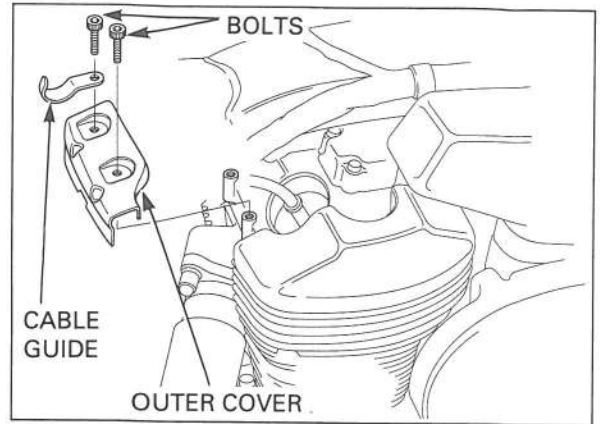

Remove the socket bolts and rear cylinder fin (cylinder head cover removal side).

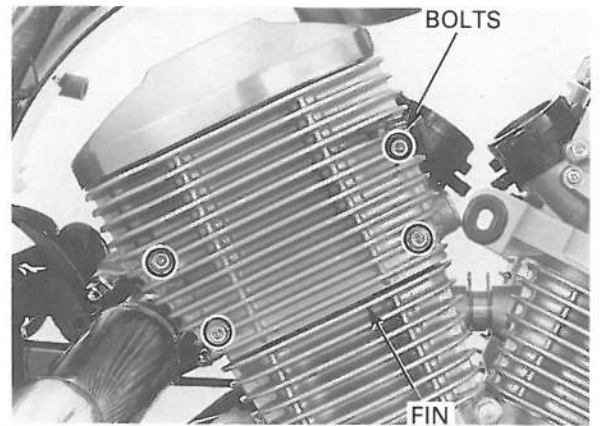

Remove the cylinder head cover bolts, washers and rubber seals.

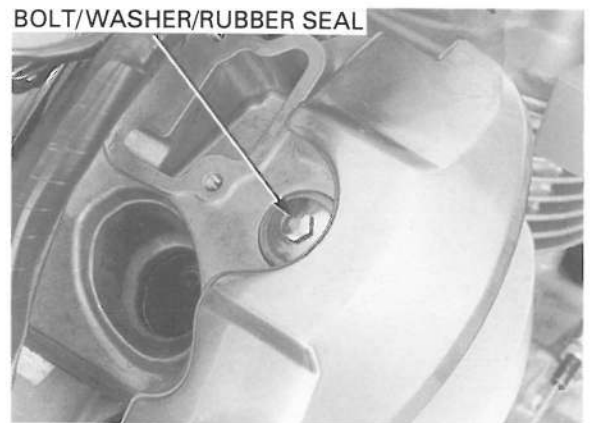

Remove the cylinder head cover and gasket.

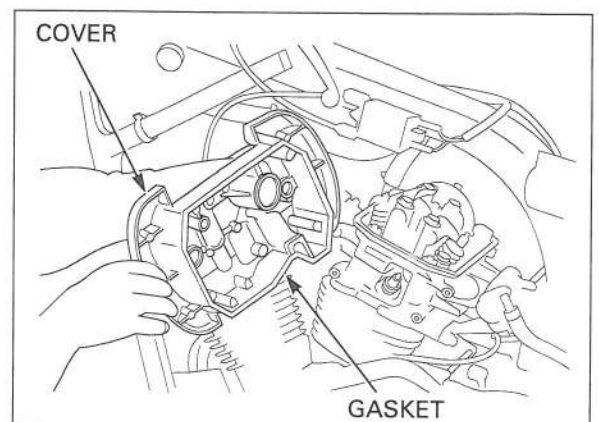

CAMSHAFT REMOVAL

NOTE:

- The camshaft can be serviced with the engine in the frame.
- The front cylinder camshaft service using the same procedure as for the rear cylinder.

Remove the front cylinder head cover (page 10-5).

Remove the crankshaft hole cap and timing hole cap from the left crankcase cover.

Remove the camshaft end holder bolts and camshaft end holder.

Remove the dowel pins.

Turn the crankshaft counterclockwise and align the "FT" mark (rear cylinder: "RT" mark) with the index mark on the left crankcase cover. For rear cylinder mark sure the rear cylinder is at TDC (top dead center).

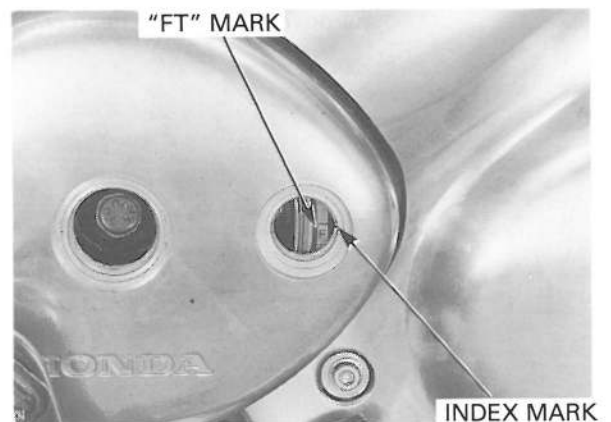
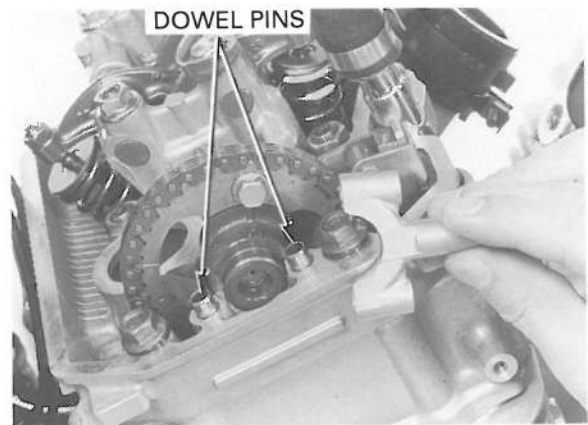
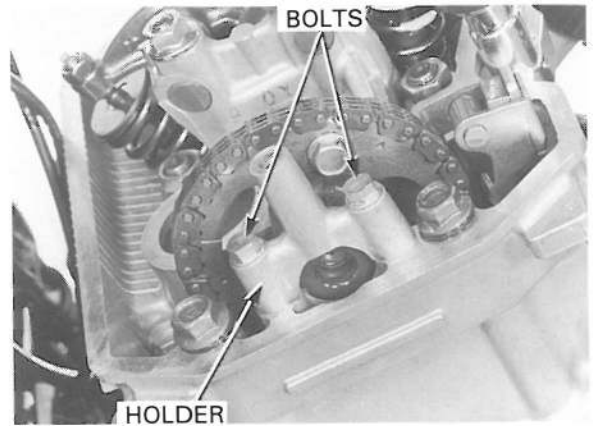
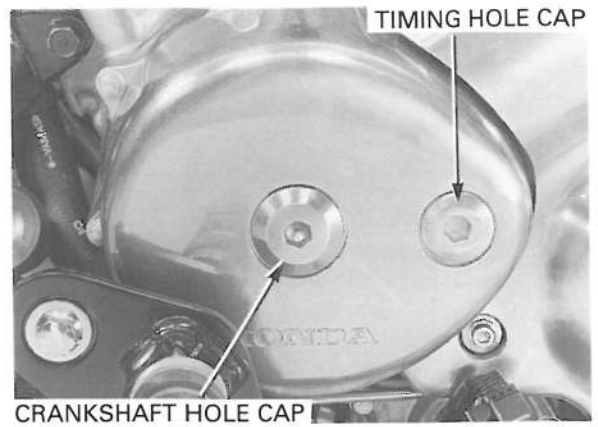

Measure the cam chain tensioner wedge B length as shown.

SERVICE LIMIT: 6 mm (0.2 in)

When the service limit is exceeded, replace the cam chain.

Replace the cam chain is after following parts removal:

Front:

- Front camshaft
- Flywheel (Section 9)

Rear:

- Rear camshaft
- Primary drive gear (Section 8)

Pull the cam chain tensioner wedge A straight up while holding wedge B push down.

Secure wedge A with a 2 mm pin as shown.

Be careful not to let the 2 mm pin fall into the crankcase.

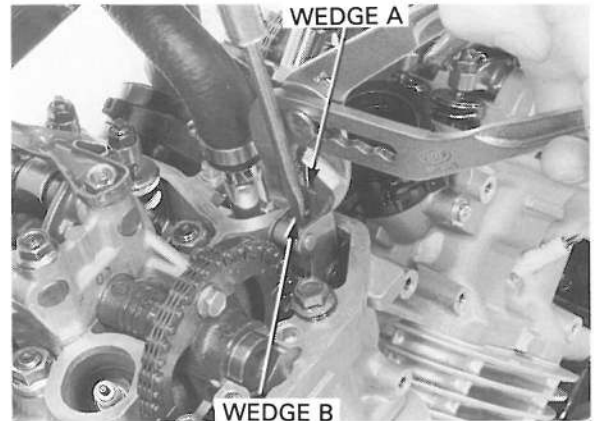
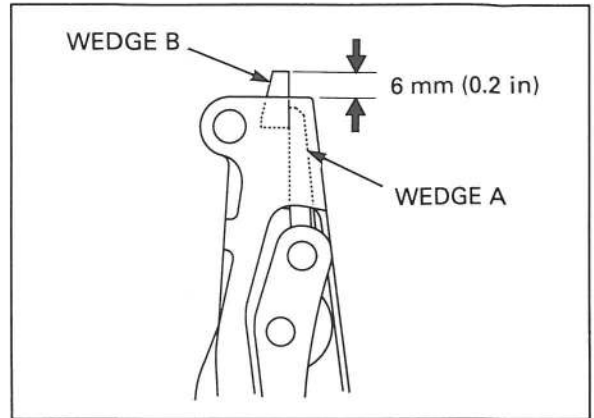

Be careful not to let the cam sprocket bolts fall into the crankcase.

Remove the cam sprocket bolt, turn the crankshaft counterclockwise one full turn (360°) and remove the other cam sprocket bolt.

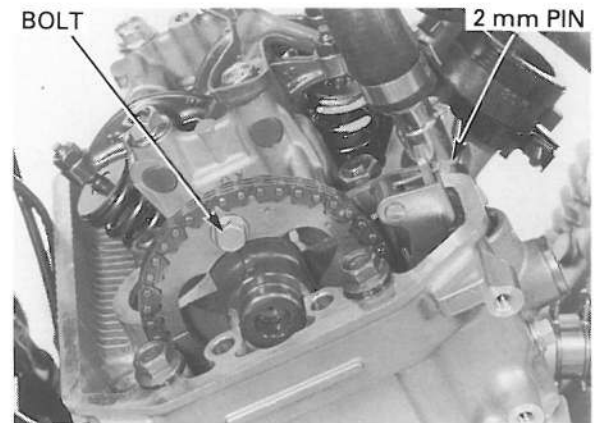

Remove the cam sprocket from the camshaft flange surface.

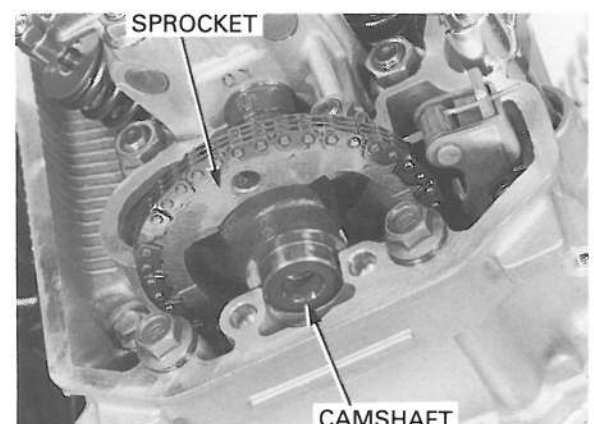

CYLINDER HEAD/VALVES

Remove the camshaft holder nuts/washer (8 mm).
Remove the camshaft holder bolts (8 mm) and oil
guide plate.
Remove the camshaft holder assembly.

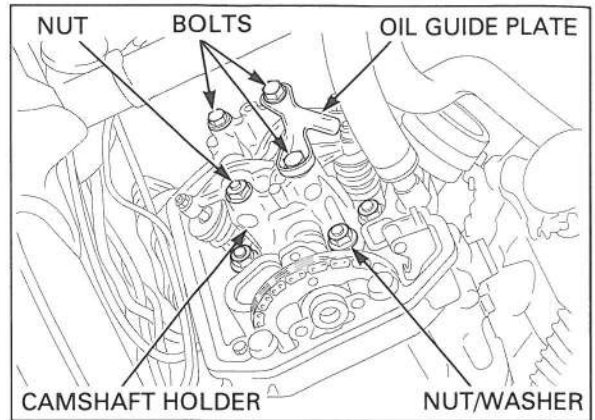

Remove the dowel pins.

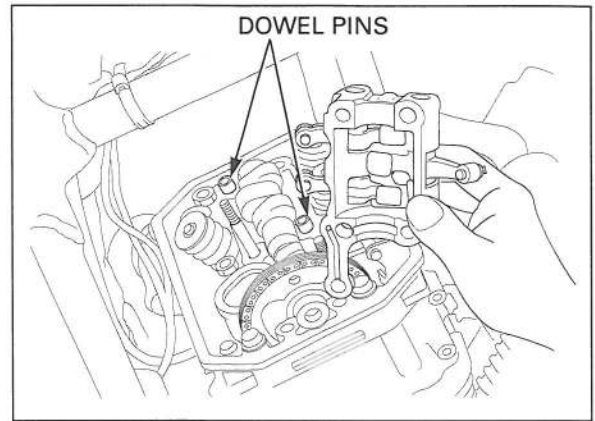

Remove the camshaft.

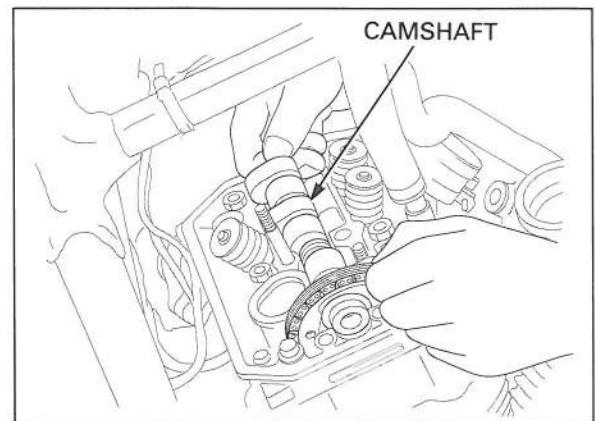

Remove the cam sprocket from cam chain.
Attach a piece of mechanic's wire to the cam chain to
prevent it from being dropped into the crankcase.

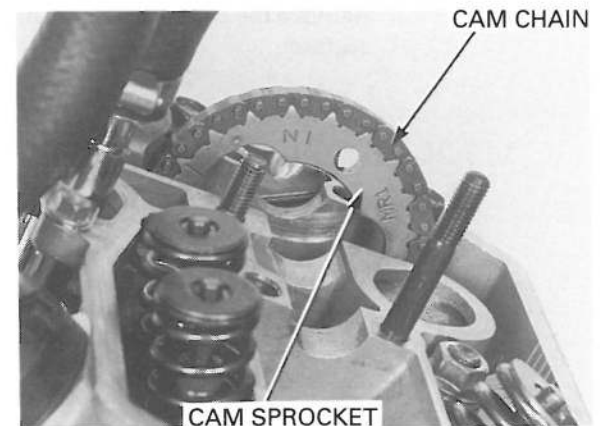

CAMSHAFT HOLDER DISASSEMBLY

NOTE:

The front cylinder camshaft holder service uses the same procedure as the rear cylinder camshaft holder.

Remove the exhaust rocker arm shaft, exhaust rocker arm and wave washer (12 mm) from the camshaft holder.

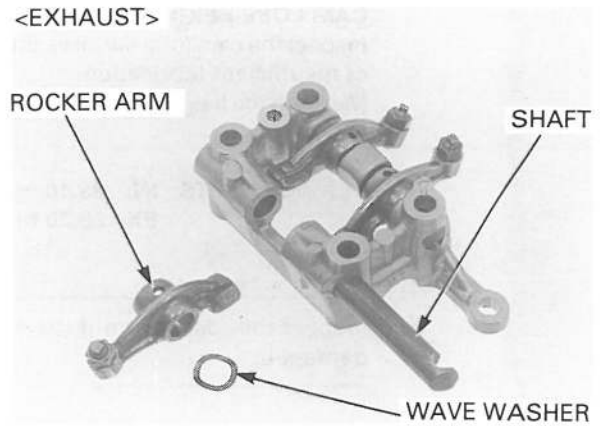

Remove the intake rocker arm shaft, intake rocker arms and wave washers (12 mm) from the camshaft holder.

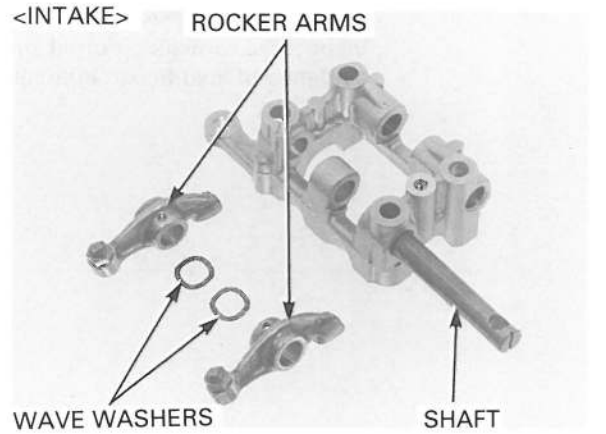

Remove the valve adjuster lock nut and valve adjusting screw.

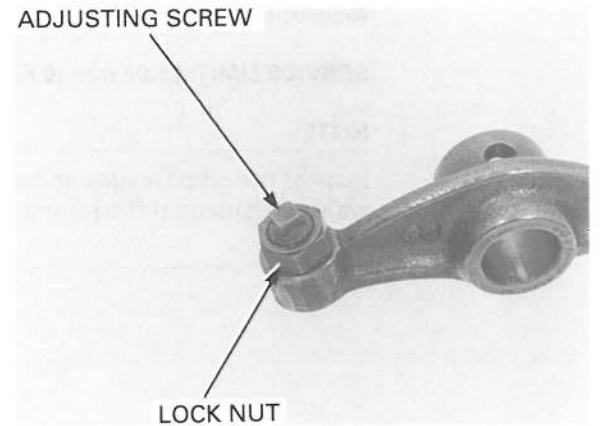

INSPECTION

CAMSHAFT RUNOUT

Support both ends of the camshaft with V-blocks and check the camshaft runout with a dial indicator. Actual runout is 1/2 the total indicator reading.

SERVICE LIMIT: 0.05 mm (0.002 in)

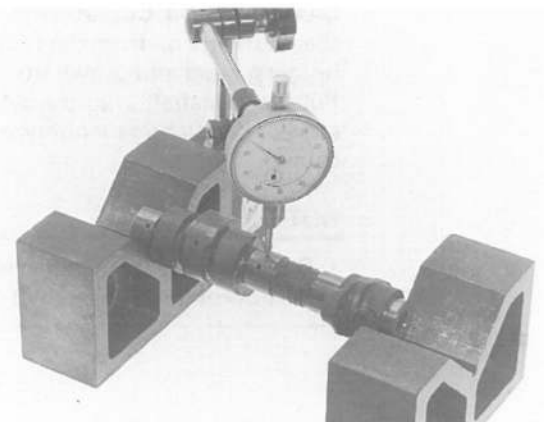

CYLINDER HEAD/VALVES

CAM LOBE HEIGHT

Inspect the cam lobe surfaces for scoring or evidence of insufficient lubrication.
Measure the height of each cam lobe using a micrometer.

SERVICE LIMITS: IN: 38.10 mm (1.500 in)
EX: 38.20 mm (1.504 in)

NOTE:

Inspect the rocker arm if the cam lobe is worn or damaged.



CAMSHAFT JOURNAL

Inspect the camshaft journal surfaces for scoring or evidence of insufficient lubrication.

Measure the O.D. of each camshaft journal.

SERVICE LIMIT: 21.90 mm (0.862 in)

NOTE:

Inspect the oil passages and camshaft holder for wear or damage if the journal surface is worn or damaged.

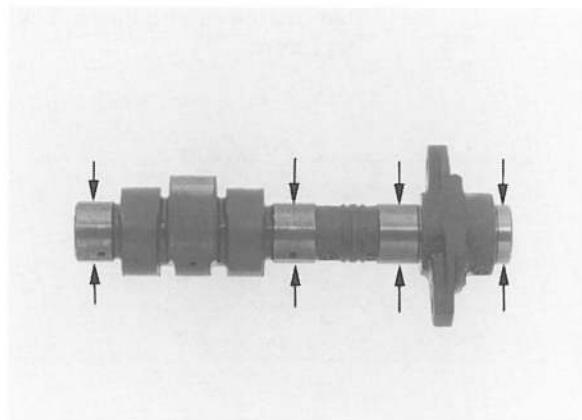
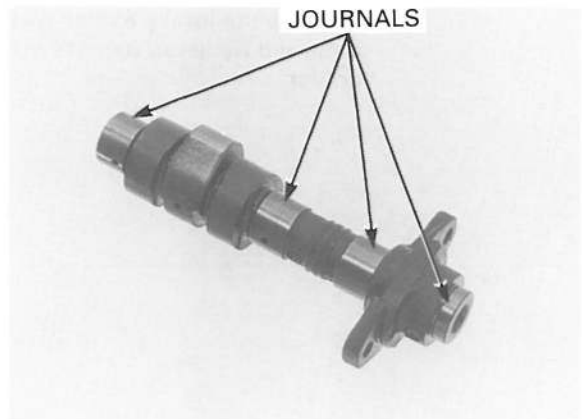

CAMSHAFT OIL CLEARANCE

Clean off any oil from the journals of the camshaft holders, head and camshafts.
Put the camshaft onto the cylinder head and lay a strip of plastigauge lengthwise on the top of each camshaft journal.

NOTE:

- Do not block any oil holes with the plastigauge.
- Do not rotate the camshaft during inspection.

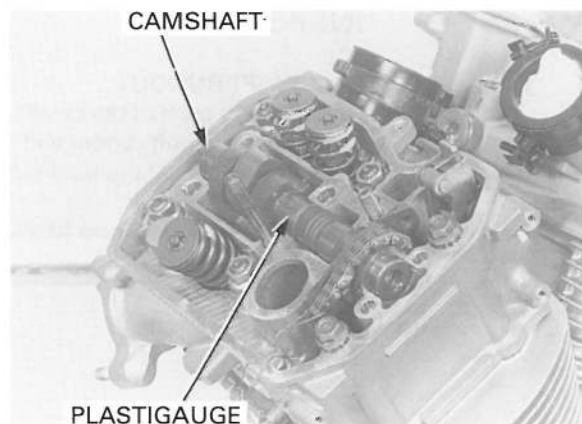

Install the camshaft holder and camshaft end holder. Install and tighten the camshaft holder bolts/nuts (8 mm) to the specified torque in 2 - 3 steps.

TORQUE: 23 N·m (2.3 kgf·m, 17 lbf·ft)

Install and tighten the camshaft holder bolts (6 mm) to the specified torque in 2 - 3 steps.

TORQUE: 10 N·m (1.0 kgf·m, 7 lbf·ft)

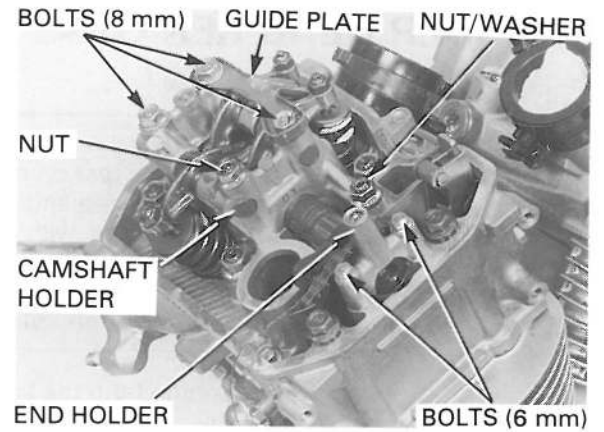

Remove the camshaft holder and measure the width of each plastigauge. The widest thickness determines the oil clearance.

SERVICE LIMIT: 0.13 mm (0.005 in)

When the service limit is exceeded, replace the camshaft and recheck the oil clearance.

Replace the cylinder head and camshaft holders if the clearance still exceeds the service limit.

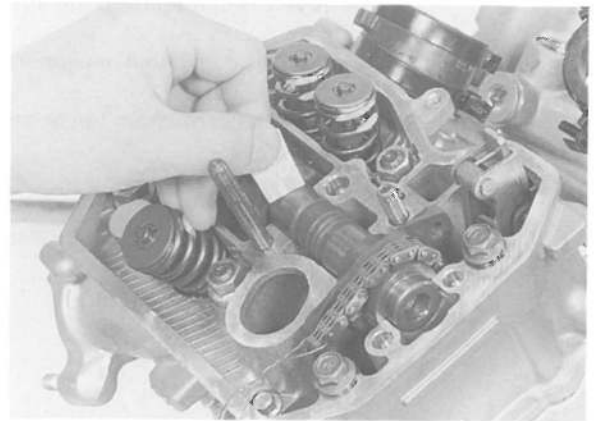

ROCKER ARM, ROCKER ARM SHAFT

Inspect the sliding surface of the rocker arms for wear or damage where they contact the camshaft, or for clogged oil holes.

Inspect the contact surface of the valve adjusting screw for wear or damage.

Measure the I.D. of each rocker arm.

SERVICE LIMIT: 12.05 mm (0.474 in)

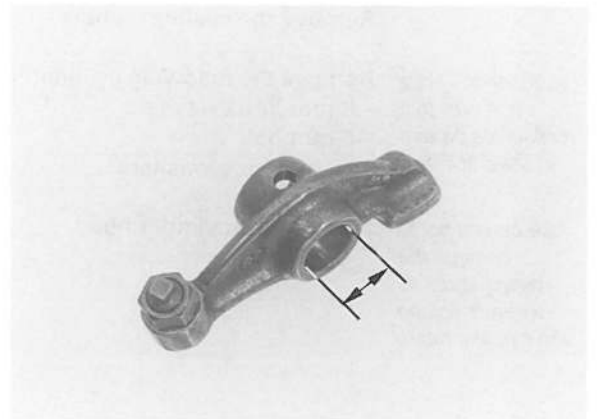

Measure the each rocker arm shaft O.D..

SERVICE LIMIT: 11.83 mm (0.466 in)

Inspect the shaft for wear or damage and calculate the shaft to rocker arm clearance.

SERVICE LIMIT: 0.07 mm (0.003 in)

Replace the rocker arm and/or shaft if necessary.

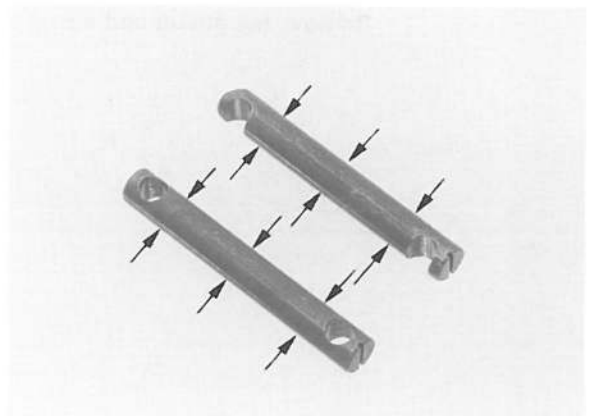

CYLINDER HEAD REMOVAL

NOTE:

- The engine must be removed from the frame before servicing the rear cylinder head.
- The front cylinder head and rear cylinder head cover can be serviced with the engine in the frame.
- The rear cylinder head service using the same procedure as for the front cylinder head.

Remove the engine from the frame (rear cylinder only/Section 7).

Remove the cylinder head cover (page 10-5).

Remove the camshaft (page 10-8).

Remove the cam chain tensioner mounting bolts and sealing washers.

Remove the cam chain tensioner.

Remove the cushion rubber.

Loosen the bolts and nuts in a crisscross pattern in several times.

Remove the following cylinder head bolts and nuts:

- 8 mm bolts/washers
- 6 mm bolt
- 10 mm nuts/washers

Be careful not to damage the mating surfaces when removing the cylinder head.

Remove the cylinder head.

Remove the gasket and dowel pins.

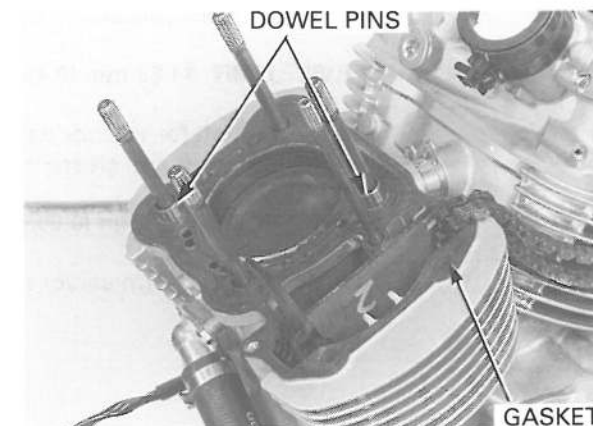
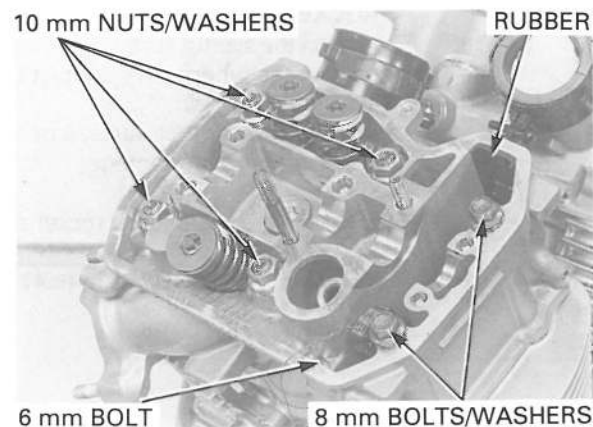
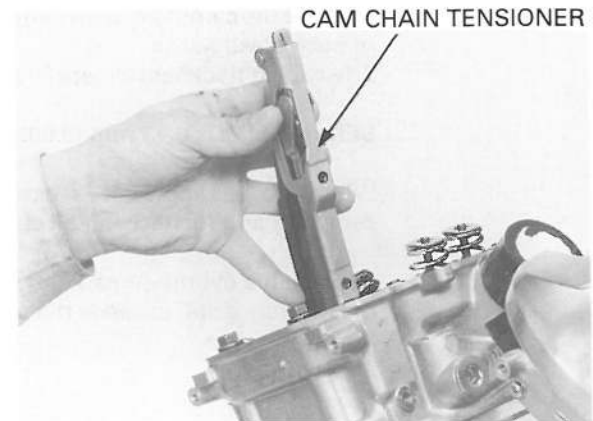
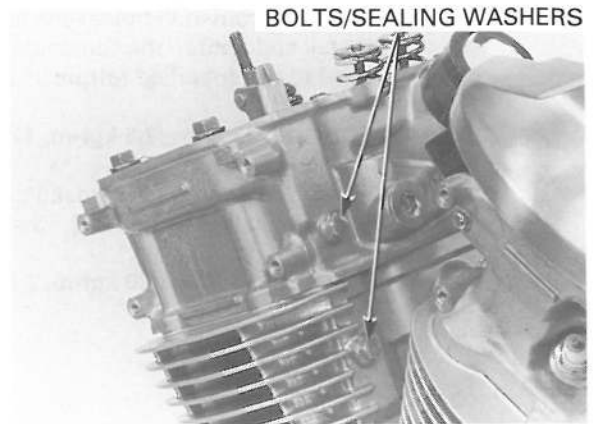

Remove the cam chain guide.

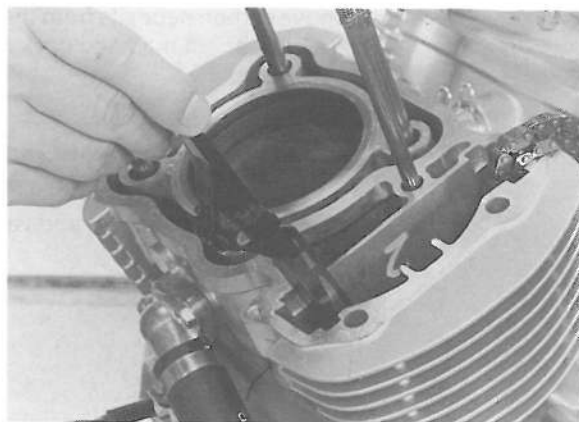

Loosen the screw and remove the carburetor insulator.

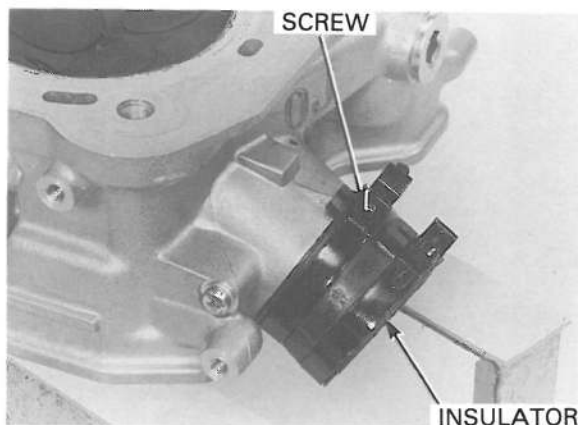

CYLINDER HEAD DISASSEMBLY

Mark all parts during disassembly so they can be placed back in their original position.

Install the valve spring compressor onto the valve and compress the valve spring.

TOOL:
Valve spring compressor 07757-0010000

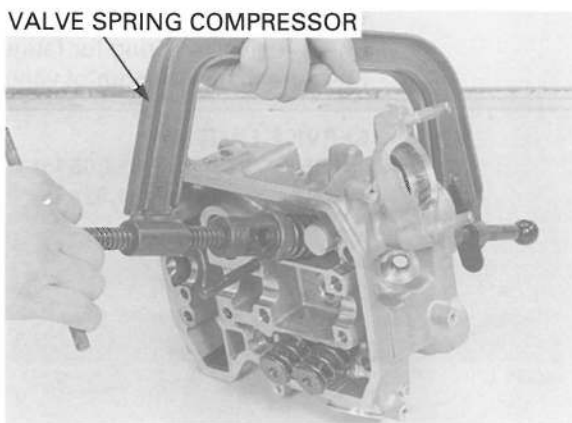

CAUTION:

Compressing the valve spring more than necessary will cause loss of valve spring tension.

Remove the valve spring compressor, then remove the retainers, springs and valves.
 Remove the stem seals and spring seats.

NOTE:

Do not reuse a removed stem seal.

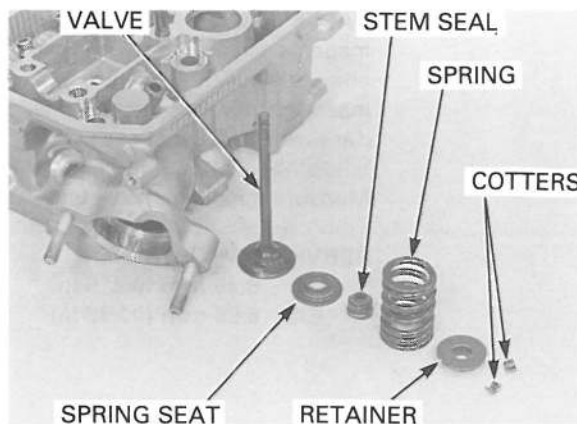

CYLINDER HEAD/VALVES

Remove carbon deposits from the combustion chamber and clean off the head gasket surface.

CAUTION:

Avoid damaging the gasket and valve seat surface.

Check the spark plug hole and valve areas for cracks.

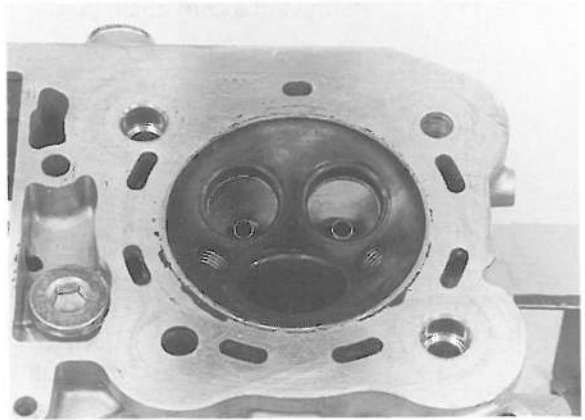

INSPECTION

CYLINDER HEAD

Check the cylinder head for warpage with a straight edge and feeler gauge.

SERVICE LIMIT: 0.10 mm (0.004 in)

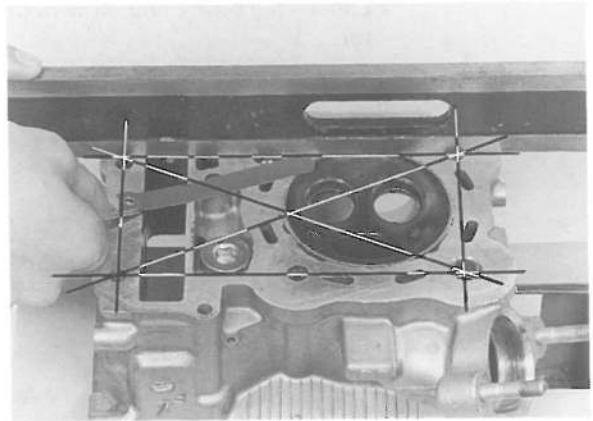

VALVE SPRING

Check the valve spring for fatigue or damage. Measure the free length of valve springs.

SERVICE LIMITS:

IN: 40.58 mm (1.598 in)

EX: 41.25 mm (1.624 in)

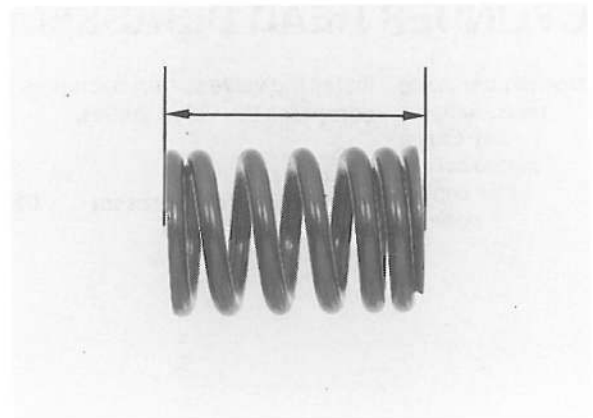

VALVE STEM, VALVE GUIDE

Inspect each valve for bending, burning, scratches or abnormal wear.

Insert the valves in their original positions in the cylinder head. Check that each valve moves up and down smoothly, without binding.

Measure the each valve stem O.D. and record it.

SERVICE LIMITS:

IN: 5.45 mm (0.215 in)

EX: 6.55 mm (0.258 in)

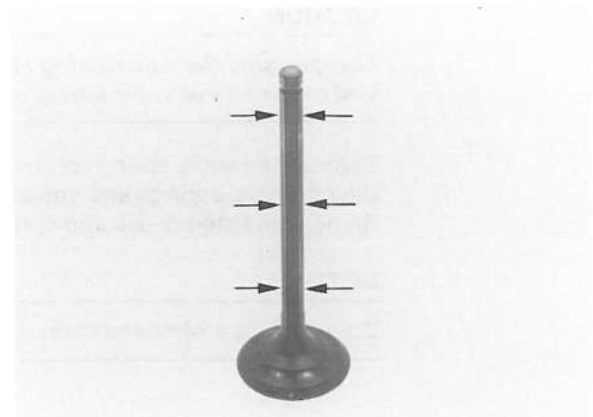

Ream the valve guide to remove any carbon build-up before measuring the guide. Insert the reamer from the combustion chamber side of the head and always rotate the reamer clockwise.

NOTE:

- Take care not to tilt or lean the reamer in the guide while reaming.
- If reaming irregular, oil will leak past the valve stem seal. If could cause improper seat contact that cannot be corrected by refacing.
- Rotate the reamer clockwise, never counterclockwise when inserting and removing.

TOOLS:

Valve guide reamer

- | | |
|---------------|--|
| 5.510 mm (IN) | 07984-2000001 or
07984-200000D
(U.S.A. only) |
| 6.612 mm (EX) | 07984-ZE20001 or
07984-ZE2000D
(U.S.A. only) |

Measure each valve guide I.D. and record it.

SERVICE LIMITS:

- IN:** 5.56 mm (0.219 in)
EX: 6.65 mm (0.262 in)

Subtract each valve stem O.D. from the corresponding guide I.D. to obtain the stem-to-guide clearance.

SERVICE LIMITS:

- IN:** 0.10 mm (0.004 in)
EX: 0.11 mm (0.004 in)

If the stem-to-guide clearance exceeds the service limit, determine if a new guide with standard dimensions would bring the clearance within tolerance. If so, replace any guides as necessary and ream to fit. If the stem-to-guide clearance exceeds the service limit with new guide, also replace the valve.

NOTE:

Inspect and reface the valve seats whenever the valve guides are replaced (see page 10-18).

CAM CHAIN GUIDE

Check the cam chain guide for wear or damage. Replace the cam chain guide if necessary.

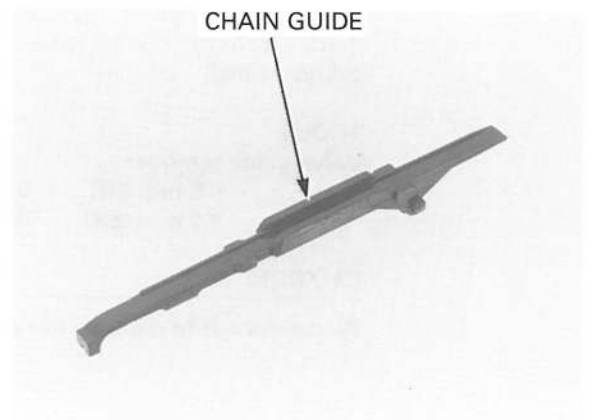
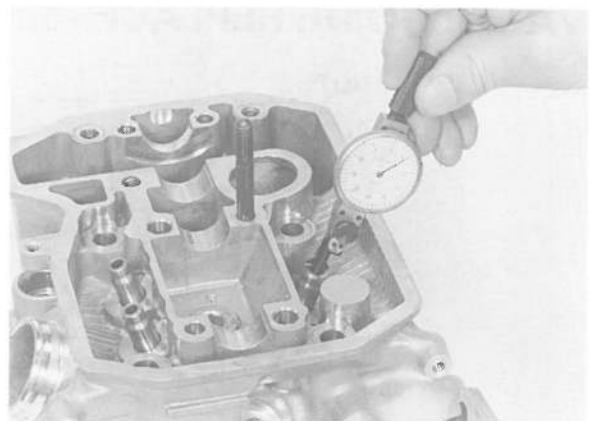
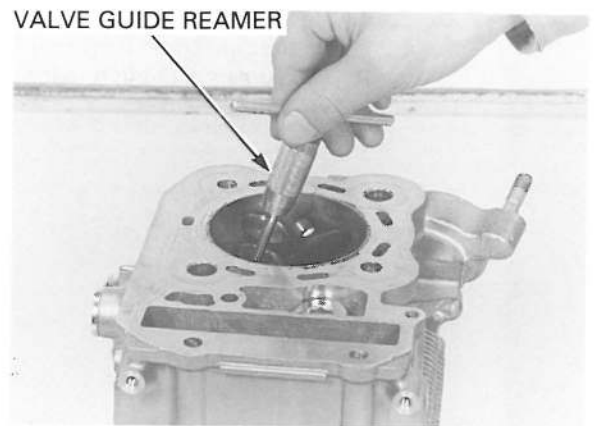

CYLINDER HEAD/VALVES

CAM CHAIN TENSIONER

Check the cam chain tensioner for wear or damage.
Replace the cam chain tensioner if necessary.

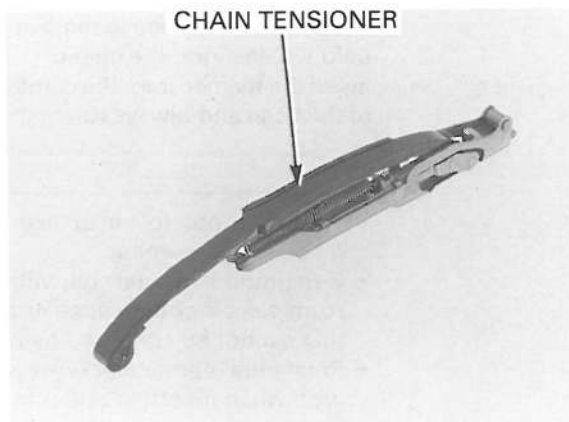

VALVE GUIDE REPLACEMENT

NOTE:

Refinish the valve seats whenever the valve guides are replaced to prevent uneven seating.

Chill the valve guides in the freezer section of refrigerator for about an hour.

⚠ WARNING

Wear insulated gloves to avoid burns when handling the heated cylinder head.

Heat the cylinder head to 130 - 140°C (275 - 290°F) with a hot plate or oven. Do not heat the cylinder head beyond 150°C (300°F). Use temperature indicator sticks, available from welding supply stores, to be sure the cylinder head is heated to proper temperature.

CAUTION:

Using a torch to heat the cylinder head may cause warping.

Support the cylinder head and drive out the old guides from the combustion chamber side of the cylinder head.

TOOLS:

Valve guide remover

5.5 mm (IN)	07742-0010100
6.6 mm (EX)	07742-0010200

CAUTION:

Be careful not to damage the cylinder head.

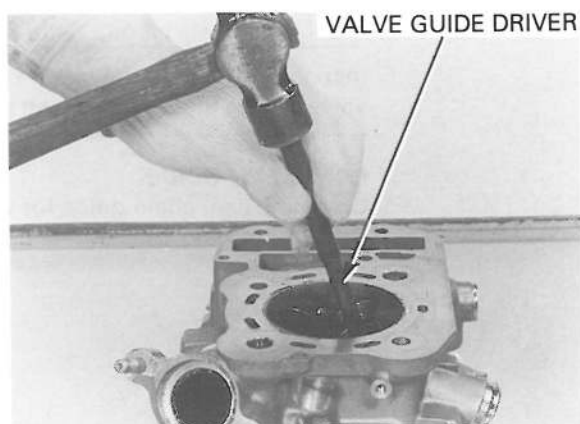

Adjust the valve guide driver to the valve guide height.

TOOL:

Valve guide driver 07743-0020000
Not available in U.S.A.

VALVE GUIDE PROJECTION ABOVE CYLINDER HEAD:

IN: 19.5 mm (0.77 in)
EX: 18.0 mm (0.71 in)

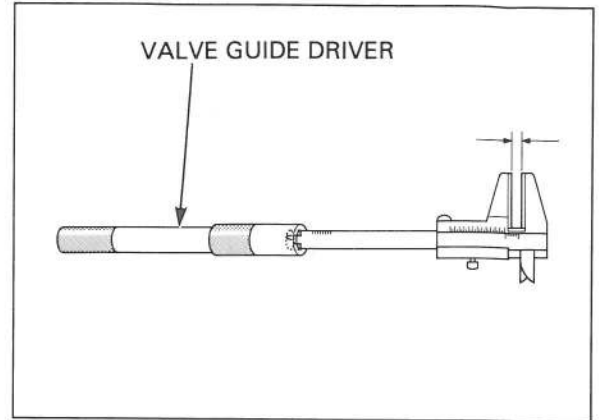

Drive the new guides in from the camshaft side of the cylinder head to the valve guide height while the cylinder head is still heated.

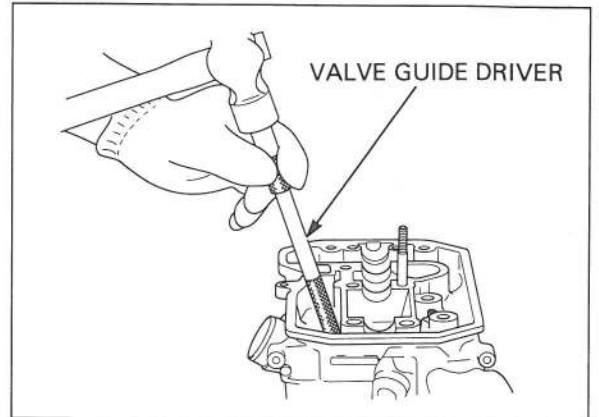

Let the cylinder head cool to room temperature, then ream the new valve guides.

TOOLS:

Valve guide reamer
5.510 mm (IN) 07984-2000001 or 07984-200000D (U.S.A. only)
6.612 mm (EX) 07984-ZE20001 or 07984-ZE2000D (U.S.A. only)

NOTE:

- Take care not to tilt or lean the reamer in the guide while reaming. Otherwise, the valves may be installed slanted, causing oil leakage from the stem seal and improper valve seat contact. This may prevent valve seat refacing.
- Insert the reamer from the combustion chamber side of the head and always rotate the reamer clockwise.

Clean the cylinder head thoroughly to remove any metal particles after reaming and refacing the valve seat.

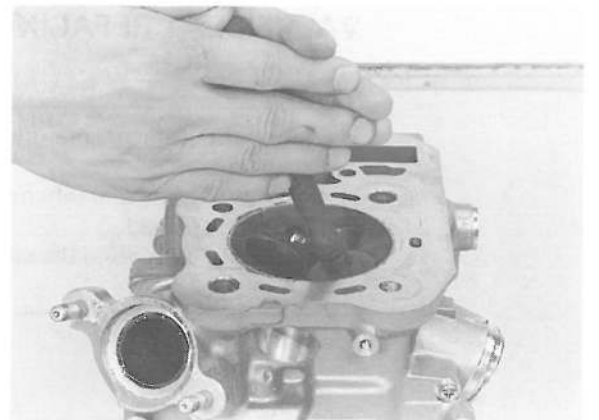
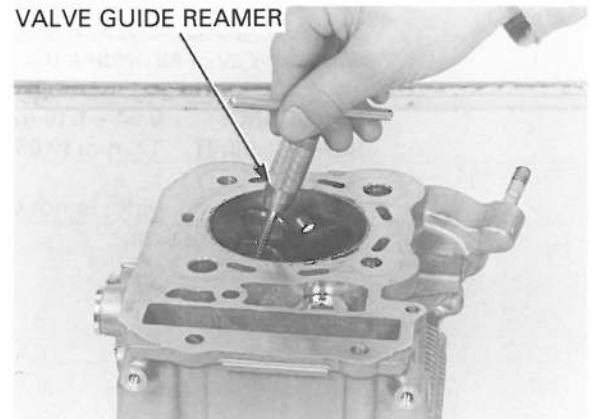

VALVE SEAT INSPECTION/REFACING

INSPECTION

Clean all intake and exhaust valves thoroughly to remove carbon deposits.

Apply a light coating of Prussian Blue to each valve face.

Tap the valve against the valve seat several times using a hand-lapping tool, without rotating valve, to make a clear pattern.

Remove the valve and inspect the valve seat face.

NOTE:

The valve cannot be ground. If the valve face is burned or badly worn or if it contacts the seat unevenly, replace the valve.

Inspect the valve seat face for:

- Uneven seat width:
 - Bent or collapsed valve stem;
 - Replace the valve and reface the valve seat.
- Damaged face:
 - Replace the valve and reface the valve seat.
- Contact area (too high or too low area):
 - Reface the valve seat.

Inspect the width of the valve seat.

The valve seat contact should be within the specified width and even all around the circumference.

STANDARD: 0.90 – 1.10 mm (0.035 – 0.043 in)
SERVICE LIMIT: 1.5 mm (0.06 in)

If the valve seat width is not within specification, reface the valve seat.

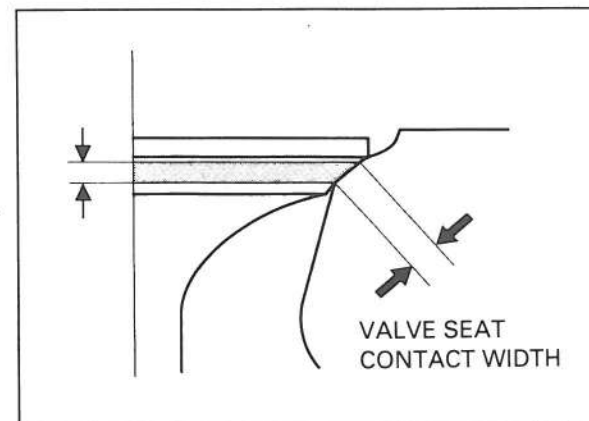
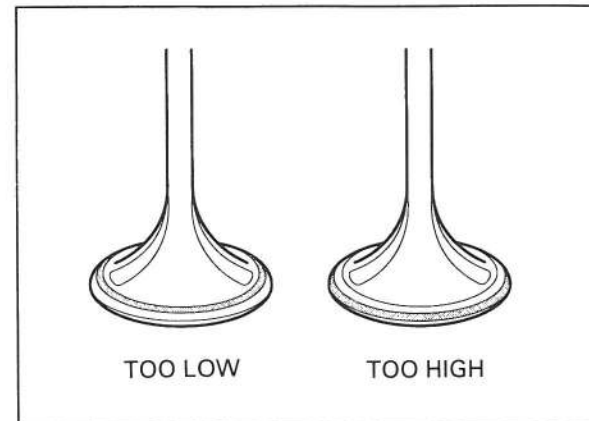
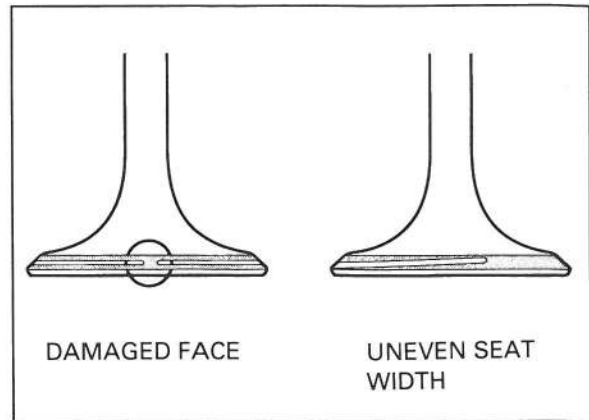

VALVE SEAT REFACING

NOTE:

- Follow the refacer manufacturer's operating instruction.
- Reface the valve seat whenever the valve guide has been replaced.
- Be careful not to grind the seat more than necessary.

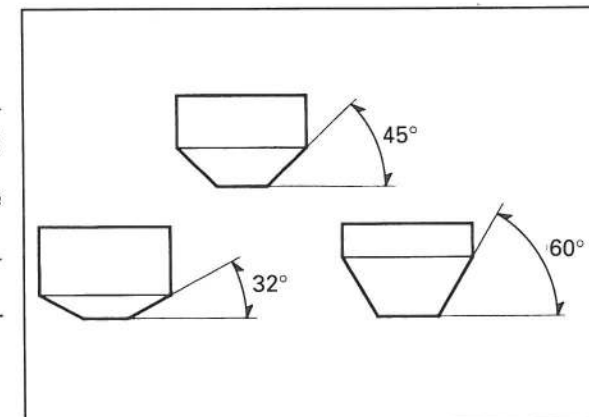

If the contact area is too high on the valve, the seat must be lowered using a 32° flat cutter.

If the contact area is too low on the valve, the seat must be raised using a 60° inner cutter. Refinish the seat to specifications, using a 45° finish cutter.

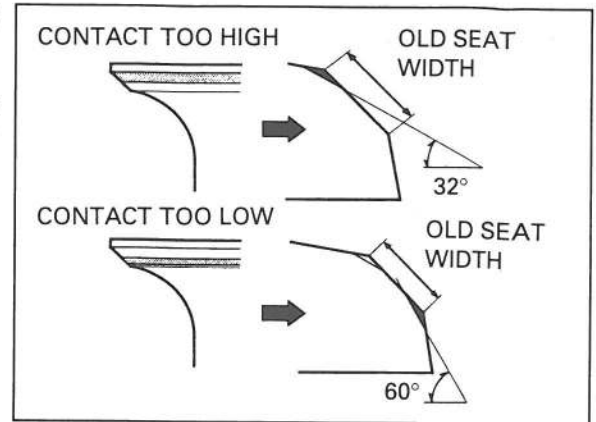

Using a 45° cutter, remove any roughness or irregularities from the seat.

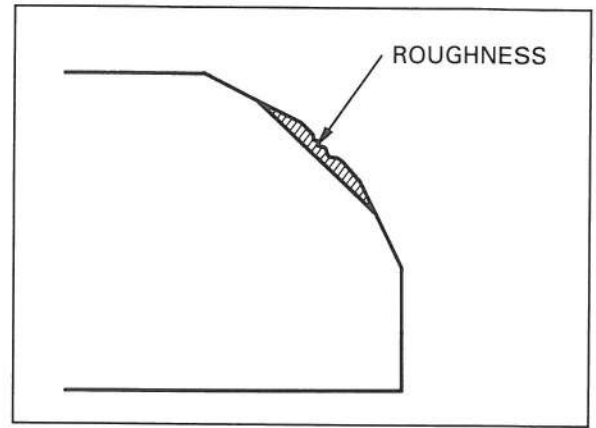

Using a 32° cutter, remove 1/4 of the existing valve seat material.

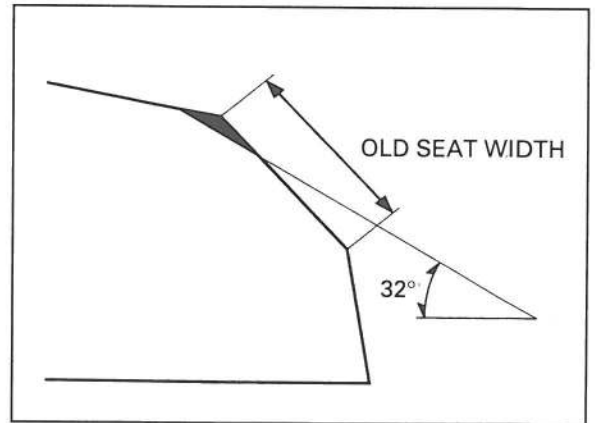

Using a 60° cutter, remove the bottom 1/4 of the old seat.

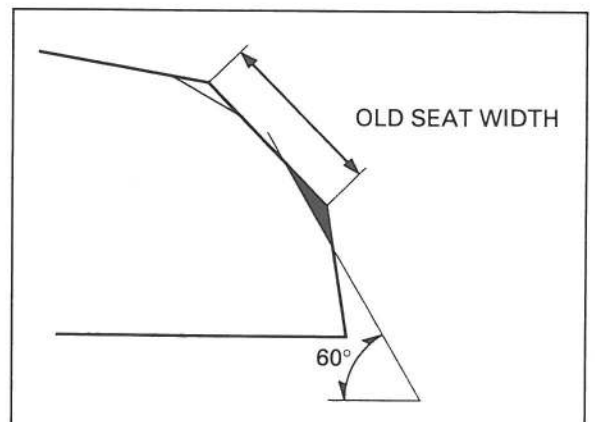

CYLINDER HEAD/VALVES

Using a 45° cutter, cut the seat to the proper width. Make sure that all pitting and irregularities are removed.

CAUTION:

- *Excessive lapping pressure may deform or damage the seat.*
- *Change the angle of lapping tool frequently to prevent uneven seat wear.*
- *Lapping compound can cause damage if it enters between the valve stem and guide.*

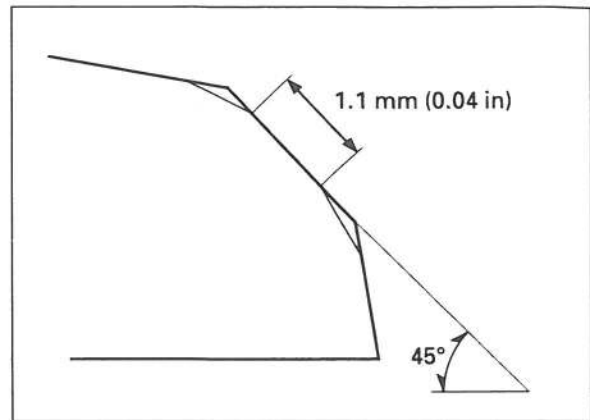

After cutting the seat, apply lapping compound to the valve face, and lap the valve using light pressure.

After lapping, wash any residual compound off the cylinder head and valve.

Recheck the seat contact after lapping.

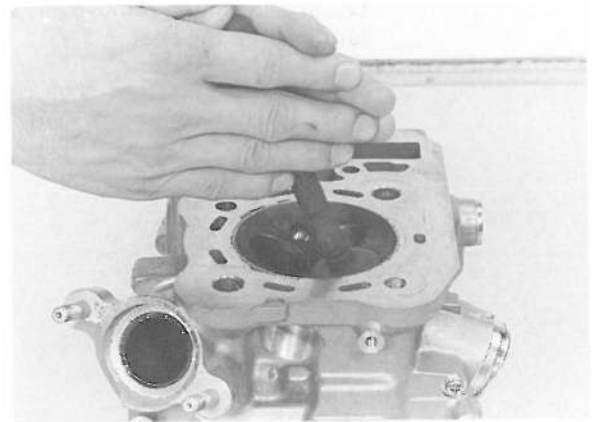

CYLINDER HEAD ASSEMBLY

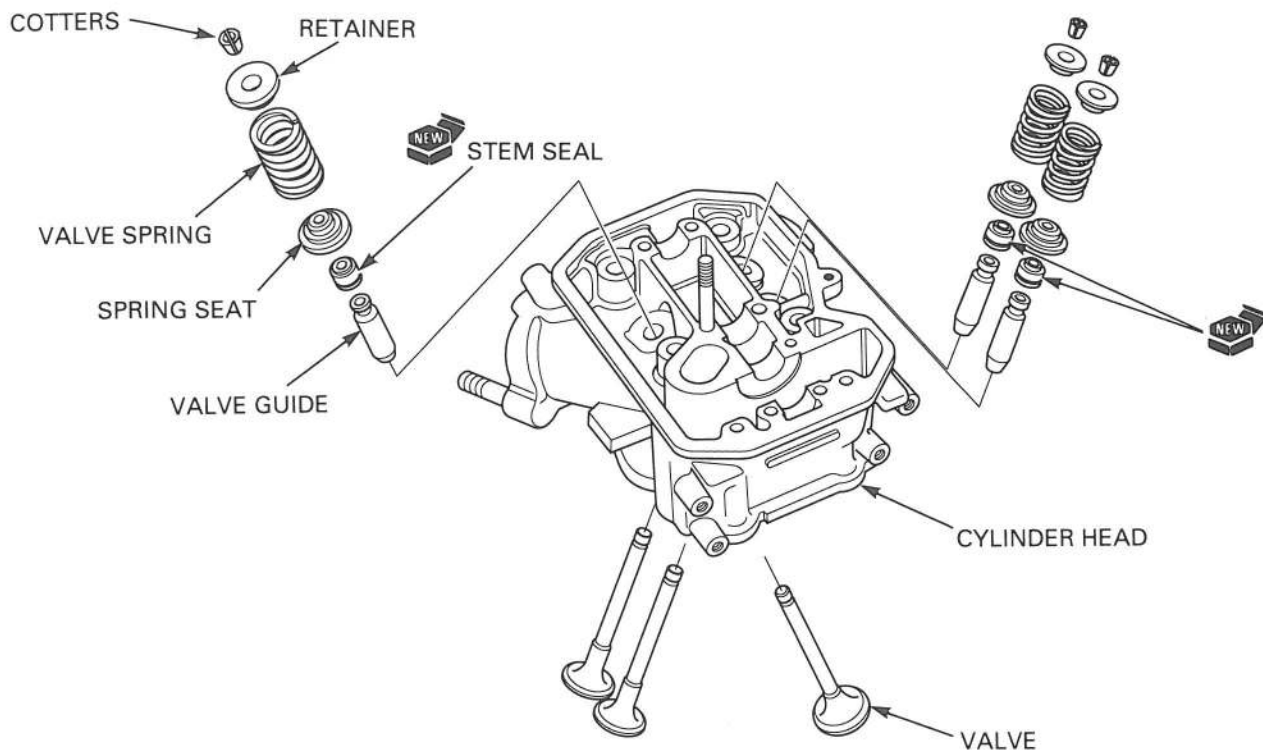

Install the spring seats and new stem seals. Lubricate each valve stems and valve guide inner surfaces with molybdenum disulfide oil.

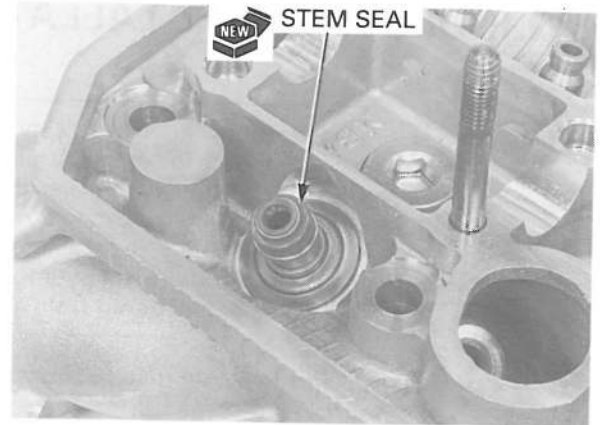

Install the valves into the valve guides.

NOTE:

To avoid damage to the stem seal, turn the valve slowly when valve installing.

Install the valve spring with tightly wound coils side facing the combustion chamber.

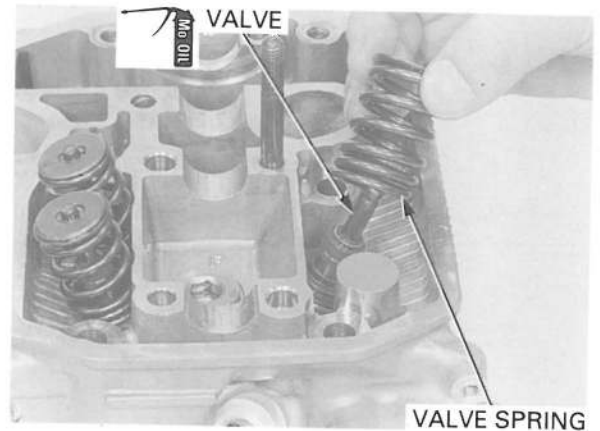

Install the retainers. Install the valve spring compressor onto the valve and compress the valve springs.

TOOL:

Valve spring compressor 07757-0010000 or
07957-3290001

CAUTION:

Compressing the valve springs more than necessary will cause loss of valve spring tension.

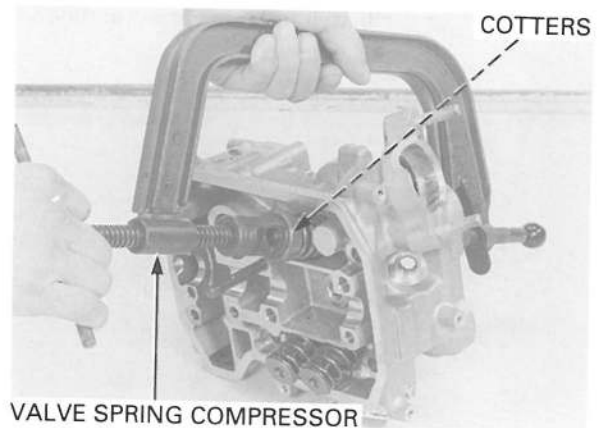

To ease installation of the cotters, grease them first.

Install the valve cotters.

NOTE:

Support the cylinder head so that the valve heads will not contact anything that causes damage.

Set the cotters firmly using two soft hammers as shown. Hold one hammer on the valve stem and gently tap it with the other hammer.

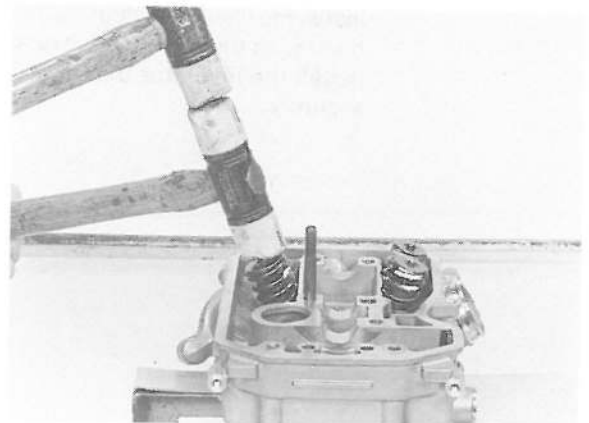

CYLINDER HEAD INSTALLATION

NOTE:

- The front cylinder head service using the same procedure as for the rear cylinder head.
- Be careful not to damage the mating surfaces when cleaning the cylinder mating surface.
- When cleaning the cylinder mating surface, place the shop towel over the cylinder opening to prevent dust or dirt from entering the engine.

Clean any gasket material from the cylinder mating surfaces.

Install the cam chain guide by aligning its tab with the groove on the cylinder.

Make sure that the end of the guide is inserted into place in the crankcase.

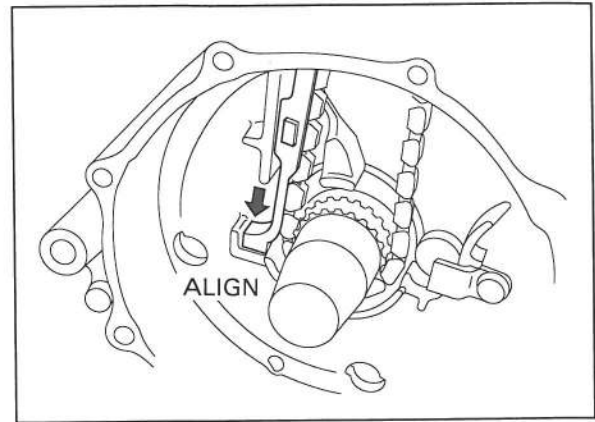
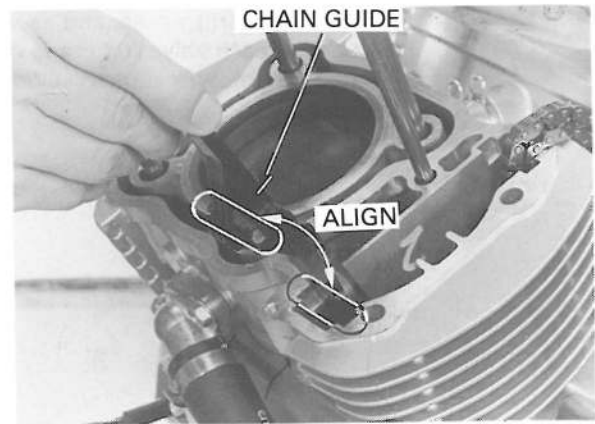

Install the dowel pins and new gasket.

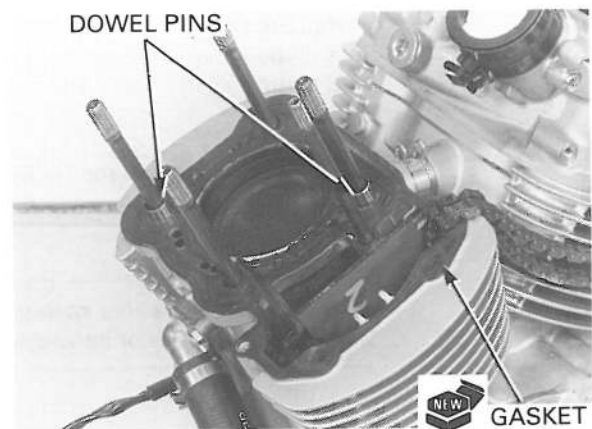

Install the insulator, aligning the boss on the cylinder head with the slot in the insulator as shown. Install the insulator bands and tighten the screws securely.

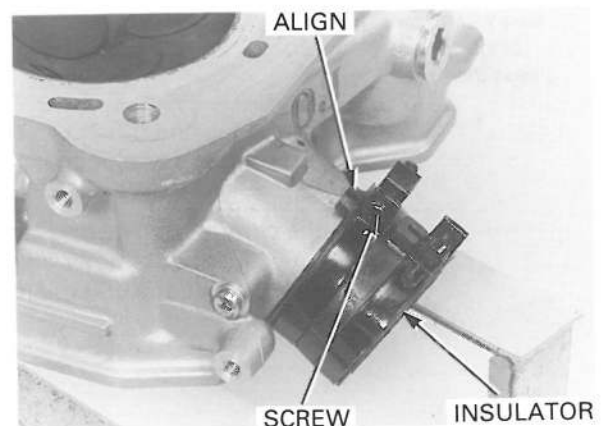

Install the cylinder head to the cylinder.

NOTE:

The cylinder heads are identified by marks on its camshaft side.

"F": Front cylinder head

"R": Rear cylinder head

Apply oil to the cylinder head 8 mm bolt threads.
Apply oil to the cylinder head each bolts and nuts seating surfaces.

Install and tighten the cylinder head bolts and nuts to the specified torque:

TORQUE:

10 mm nut: 47 N·m (4.8 kgf·m, 35 lbf·ft)

8 mm bolt/nut: 23 N·m (2.3 kgf·m, 17 lbf·ft)

6 mm bolt: 12 N·m (1.2 kgf·m, 9 lbf·ft)

NOTE:

- Tighten all to hand-tight, then torque the larger fasteners before tightening the smaller fasteners.
- Tighten the bolts and nuts in a crisscross pattern in several steps.

Install the cushion rubber.

Install the cam chain tensioner aligning its end with the groove on the crankcase.

Install the new sealing washers.

Clean and apply a locking agent to the cam chain tensioner bolt threads.

Install and tighten the cam chain tensioner mounting bolt to the specified torque.

TORQUE: 10 N·m (1.0 kgf·m, 7 lbf·ft)

Install the engine to the frame (rear cylinder only/Section 7).

Install the camshaft (page 10-26).

Install the cylinder head cover (page 10-32).

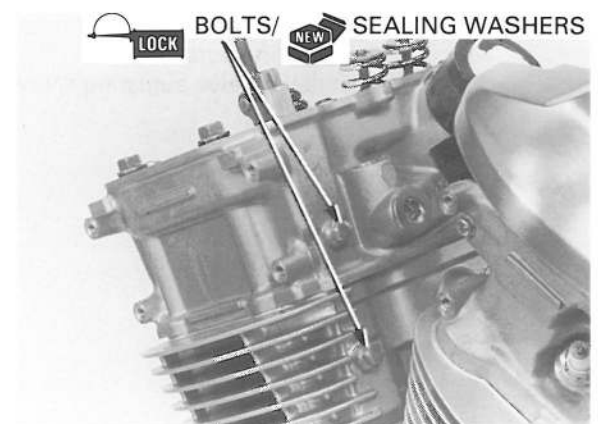
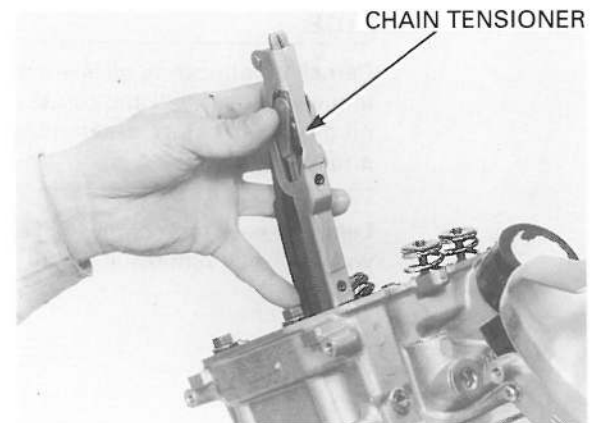
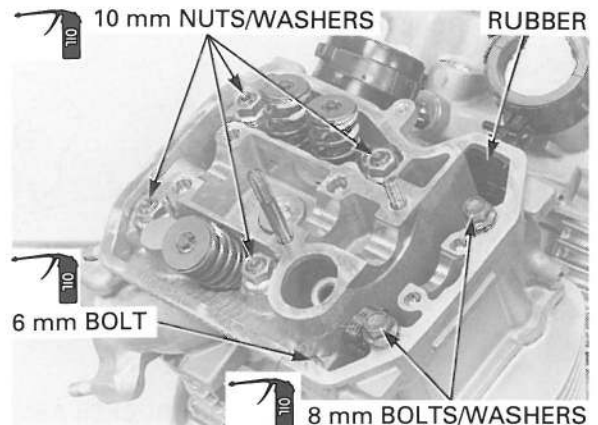
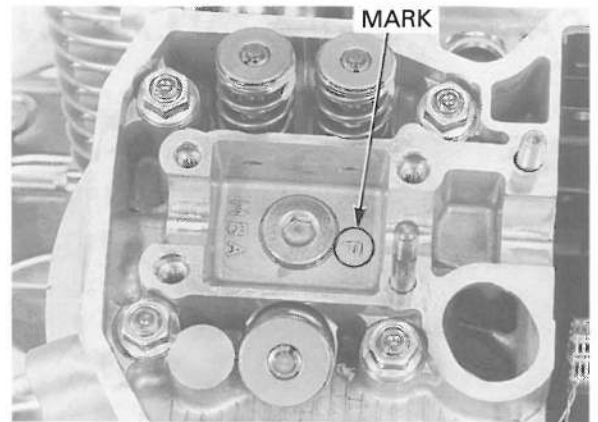

CAMSHAFT INSTALLATION

CAMSHAFT HOLDER ASSEMBLY

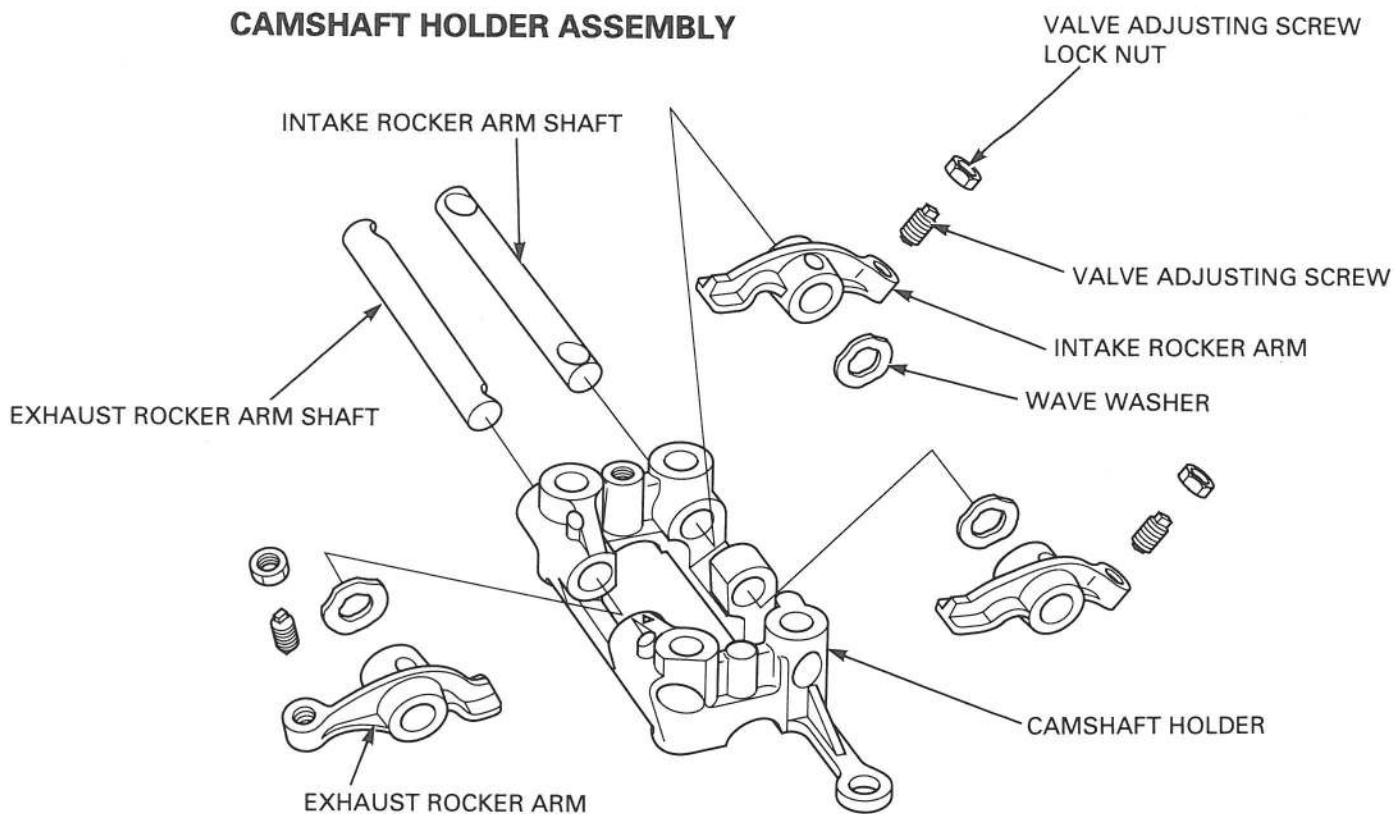

NOTE:

Camshaft lubricating oil is fed through oil passages in the cylinder head and camshaft holder. Clean the oil passages before assembling the cylinder head and camshaft holder.

Lubricate each rocker arm shaft outer sliding surfaces with molybdenum disulfide oil.

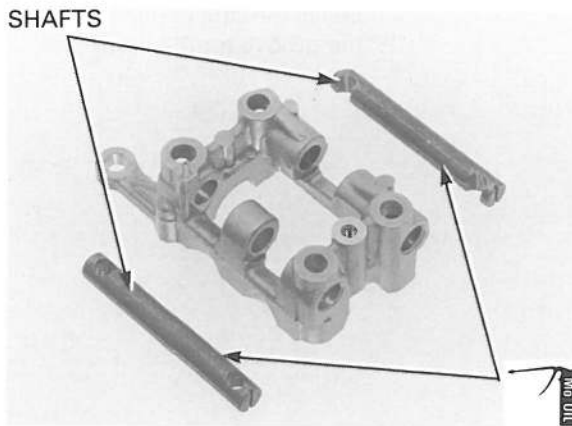

Apply engine oil to the valve adjusting screw threads and seating surface. Install the valve adjusting screw and lock nut.

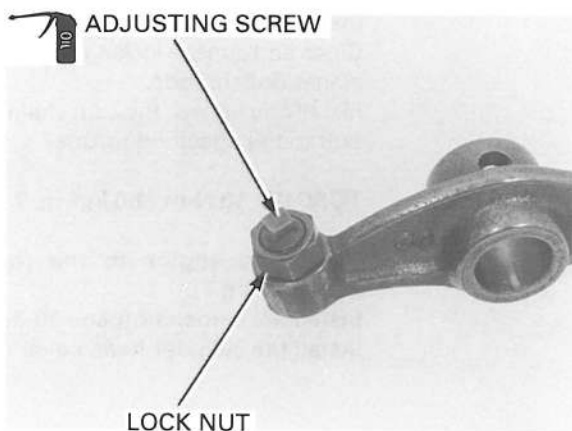

NOTE:

- The exhaust rocker arm has larger slipper face than the intake rocker arm.
- The intake rocker arm shaft has two holes on each end.
- The exhaust rocker arm shaft has two grooves on each end.

Install the wave washer (12 mm), intake rocker arm and intake rocker arm shaft to the camshaft holder.

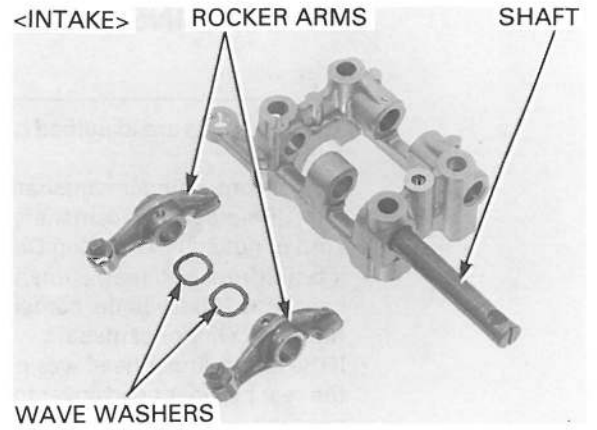

Install the wave washer (12 mm) to the "Δ" mark side on the camshaft holder.
Install the exhaust rocker arm and exhaust rocker arm shaft to the camshaft holder.

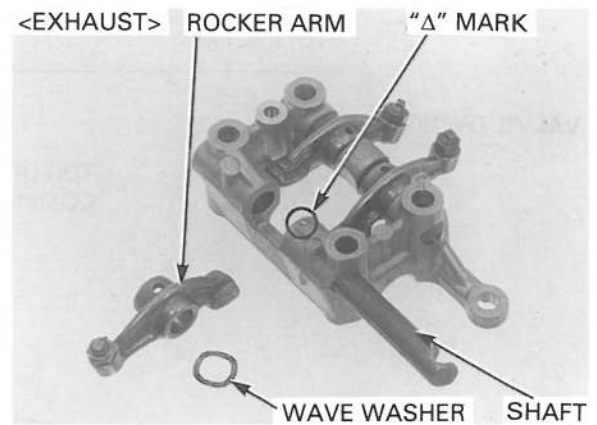

Position the grooves and holes in the rocker arm shafts vertically, aligning the bolt holes of the holder.

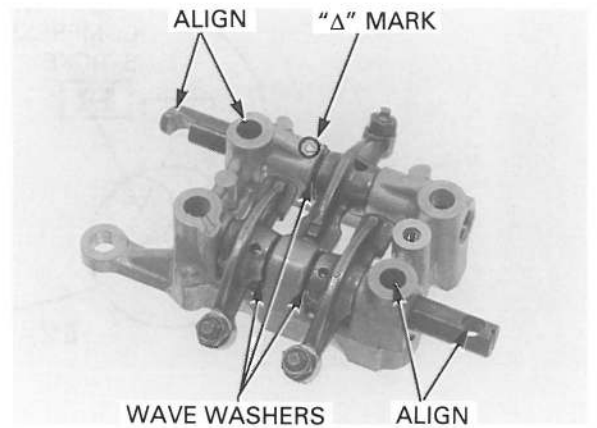

CAMSHAFT INSTALLATION

NOTE:

- The camshafts are identified by marks on their flanges:
 - “F”: Front cylinder camshaft
 - “R”: Rear cylinder camshaft
 - “Index notch”: TDC (Top Dead Center) mark
- If both (front and rear) camshafts were removed, install the front cylinder camshaft first, then install the rear cylinder camshaft.
- If the rear cylinder head was not serviced, remove the rear cylinder head cover to check the camshaft position.
- If the front cylinder head was not serviced, remove the front cylinder head cover to check the camshaft position.

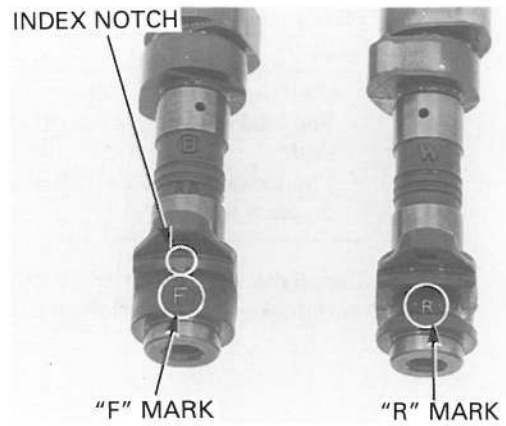

VALVE TIMING

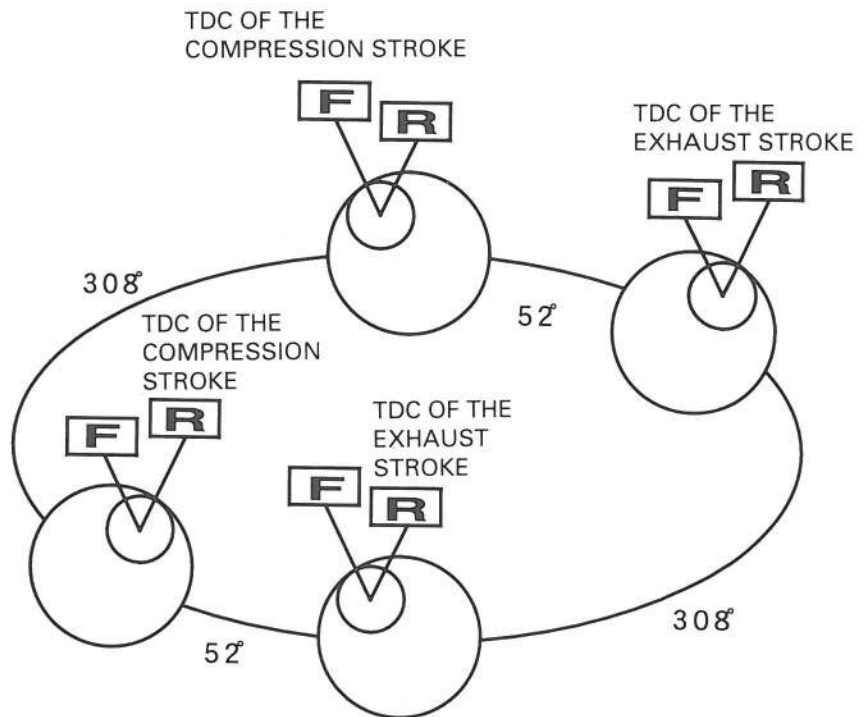

BOTH CYLINDER CAMSHAFT SERVICE

Remove the timing hole cap.

Turn the crankshaft counterclockwise and align the “FT” mark on the flywheel with the index mark on the left crankcase cover, then check the front cylinder piston is “TDC (Top Dead Center)”.

Install the front cylinder camshaft (page 10-29).



Then turn the crankshaft counterclockwise 232° and align the "RT" mark on the flywheel with the index mark on the left crankcase cover, then install the rear camshaft (see below).

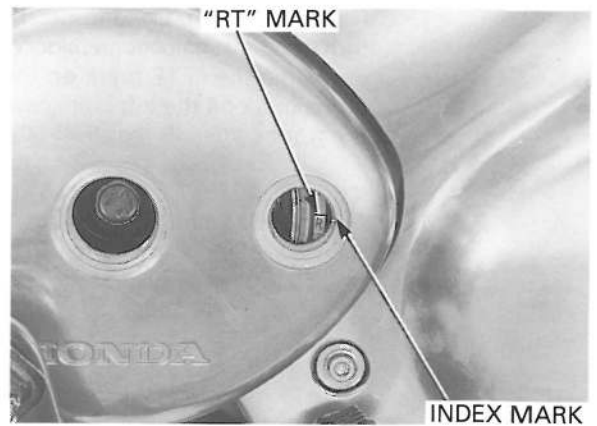

REAR CYLINDER CAMSHAFT SERVICE ONLY (FRONT CYLINDER CAMSHAFT WAS NOT SERVICED)

If the front cylinder head was not serviced, remove the front cylinder head cover (page 10-5) and check the camshaft position as follows:

Remove the front cylinder head camshaft end holder (page 10-8).

Remove the timing hole cap.

Turn the crankshaft counterclockwise and align the "FT" mark on the flywheel with the index mark on the left crankcase cover, then check that the camshaft "TDC (Top Dead Center)" mark is facing up.

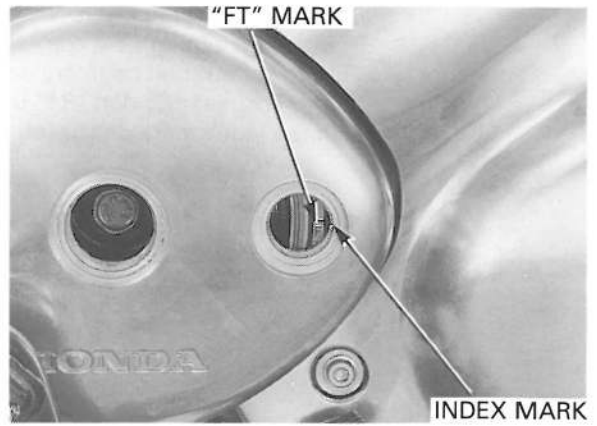

If the "TDC (Top Dead Center)" mark is facing up, turn the crankshaft counterclockwise 308° and align the "RT" mark on the flywheel with the index mark on the left crankcase cover, then install the rear camshaft (page 10-30).

If the "TDC (Top Dead Center)" mark is facing down, turn the crankshaft counterclockwise 668° (360°+308°) and align the "RT" mark on the flywheel with the index mark on the left crankcase cover, then install the rear camshaft (page 10-30).

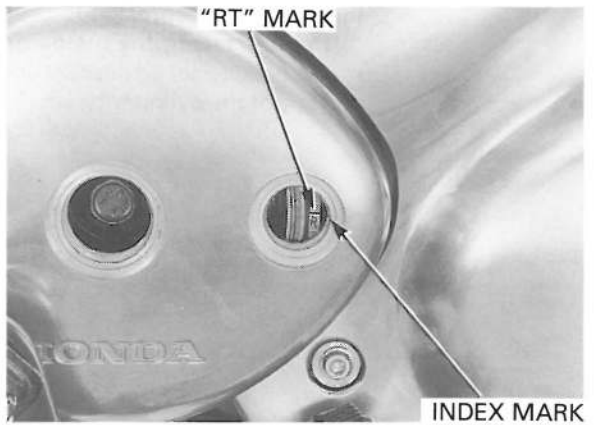

FRONT CYLINDER CAMSHAFT SERVICE ONLY (REAR CYLINDER CAMSHAFT WAS NOT SERVICED)

If the front cylinder head was not serviced, remove the rear cylinder head cover (page 10-6) and check the camshaft position as follows:

Remove the front cylinder head camshaft end holder (page 10-8).

Remove the timing hole cap.

Turn the crankshaft counterclockwise and align the "RT" mark on the flywheel with the index mark on the left crankcase cover, then check that the camshaft "TDC (Top Dead Center)" mark is facing up.

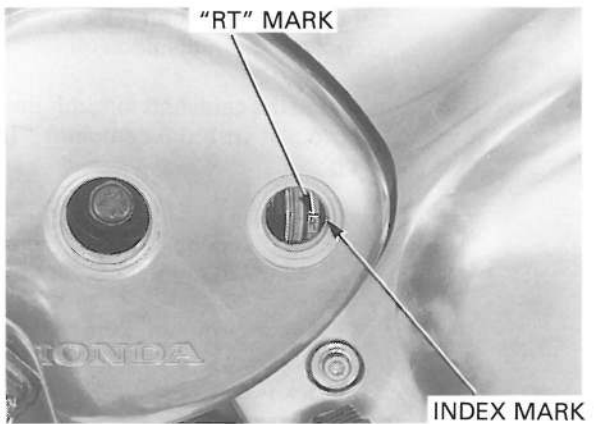

CYLINDER HEAD/VALVES

If the "TDC (Top Dead Center)" mark is facing up, turn the crankshaft counterclockwise 412° (360°+52°) and align the "FT" mark on the flywheel with the index mark on the left crankcase cover, then install the front camshaft (page 10-30).

If the "TDC (Top Dead Center)" mark is facing down, turn the crankshaft counterclockwise 52° and align the "FT" mark on the flywheel with the index mark on the left crankcase cover, then install the front camshaft (page 10-30).

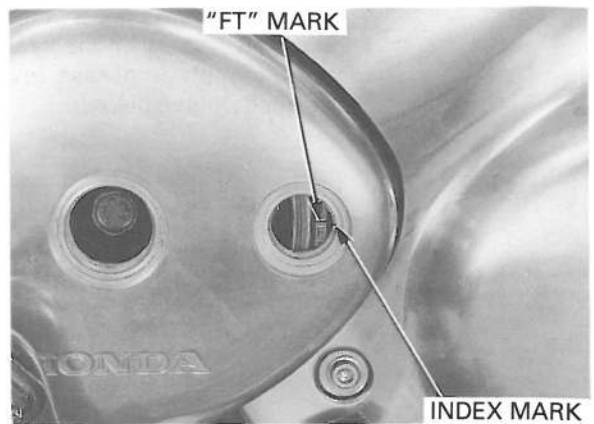

CAMSHAFT INSTALLATION

Remove the timing hole cap.

Turn the crankshaft counterclockwise and align the "FT" mark (rear cylinder: "RT" mark) on the flywheel with the index mark on the left crankcase cover.

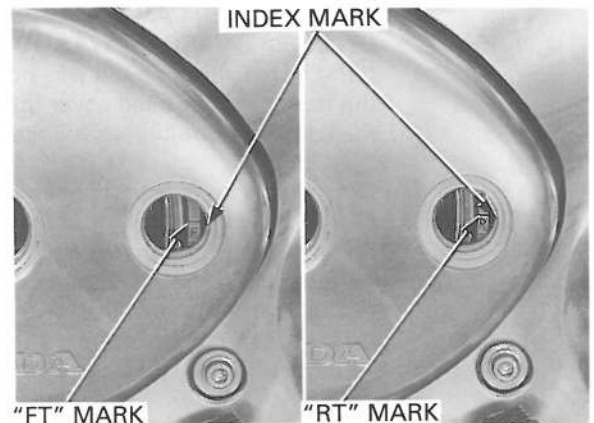

Install the cam sprocket to the cam chain with the "IN" mark facing the inside and align the timing marks (index line) on the cam sprocket and the upper surface of the cylinder head.

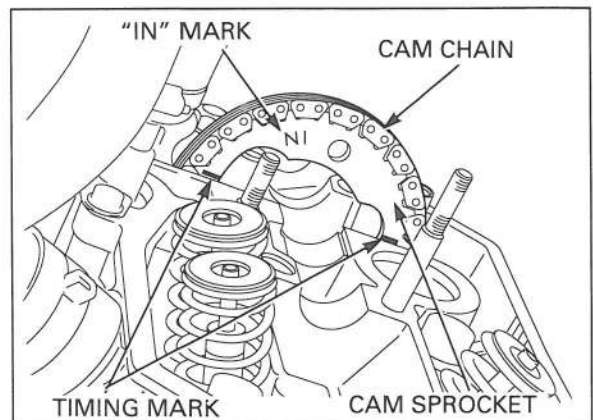

Lubricate camshaft lobe and journal surfaces with molybdenum disulfide oil.

Install the camshaft through the cam chain and cam sprocket with the camshaft "TDC" mark is facing up.

NOTE:

The camshafts are identified by marks on the their flanges:

"F": Front cylinder camshaft

"R": Rear cylinder camshaft

"Index notch": TDC (Top Dead Center) mark

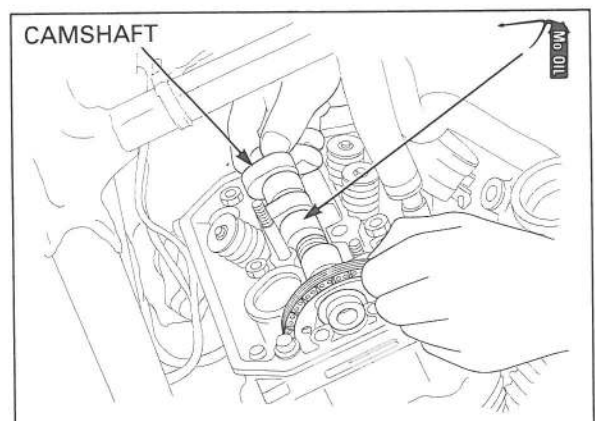

Install the dowel pins.
Lubricate each rocker arm slipper surfaces with molybdenum disulfide oil.

NOTE:

Before camshaft holder installation, loosen the valve adjusting screw and lock nut fully.

Install the camshaft holder assembly.

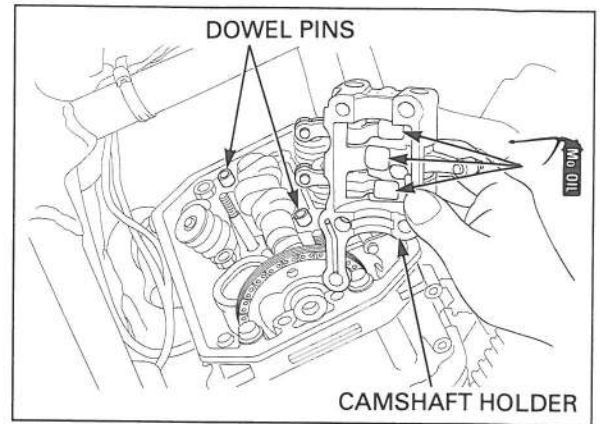

Install the oil guide plate.
Install the camshaft holder bolts (8 mm), nuts and washer (8 mm).
Tighten the bolts (8 mm) and nuts (8 mm) to the specified torque.

TORQUE: 8 mm bolt: 23 N•m (2.3 kgf•m, 17 lbf•ft)
8 mm nut: 23 N•m (2.3 kgf•m, 17 lbf•ft)

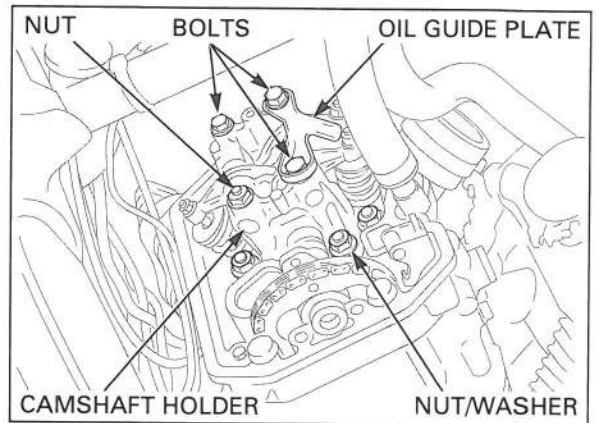

Install the cam sprocket on the camshaft flange and recheck that the timing marks align with the upper surface of the cylinder head.

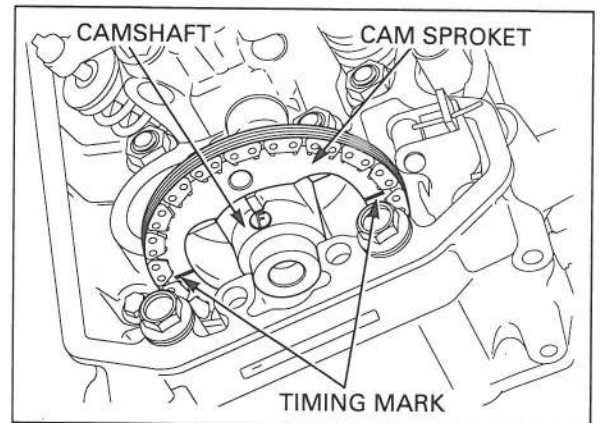

Be careful not to let the cam sprocket bolts fall into the crankcase.

Clean and apply a locking agent to the cam sprocket bolt threads.

Align the cam sprocket bolt holes in the cam sprocket and camshaft.

Temporarily install the cam sprocket bolt.

Turn the crankshaft counterclockwise 360° and tighten other sprocket bolt to the specified torque.

TORQUE: 23 N•m (2.3 kgf•m, 17 lbf•ft)

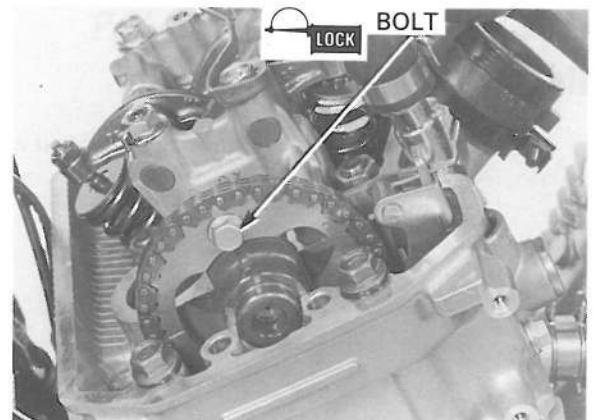

CYLINDER HEAD/VALVES

Turn the crankshaft counterclockwise 360° and tighten other sprocket bolt to the specified torque.

Remove the 2 mm pin holding cam chain tensioner wedge A.

NOTE:

- Be careful not to let the 2 mm pin fall into the crankcase.
- Do not forget to remove the 2 mm pin before installing the cylinder head cover.

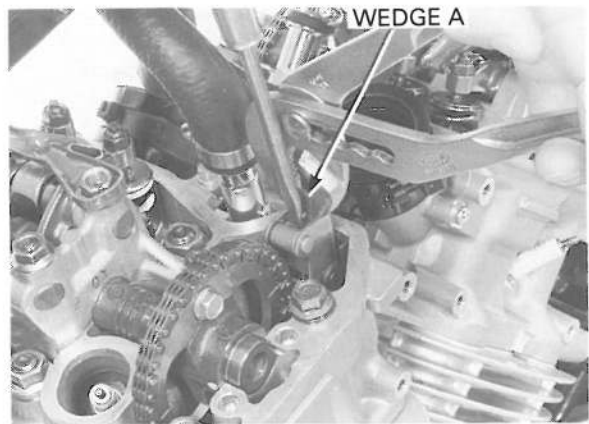

Install the dowel pins.
Install the camshaft end holder with its flat surface on the holder facing in.

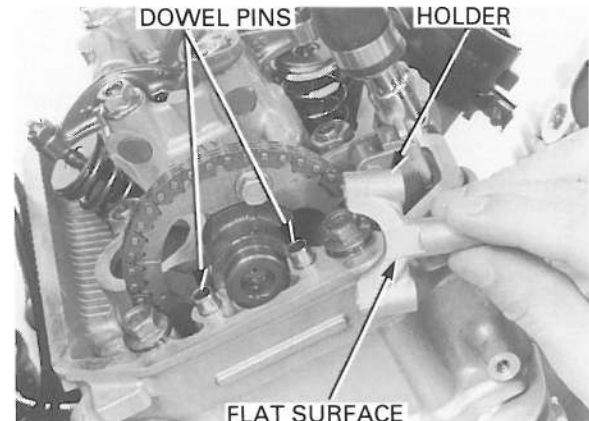

Install and tighten the camshaft end holder bolts to the specified torque.

TORQUE: 10 N·m (1.0 kgf·m, 7 lbf·ft)

Adjust the valve clearance (page 3-9).

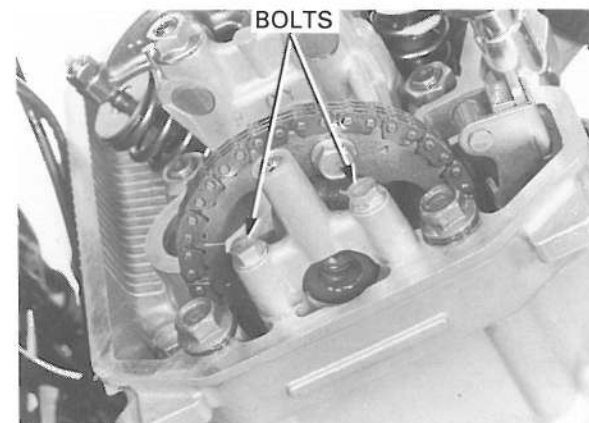

CYLINDER HEAD COVER INSTALLATION

Fill the oil pockets in the head with the engine oil.

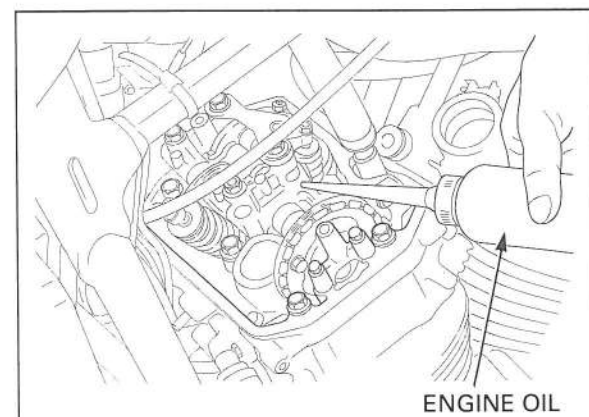

Clean the gasket groove and cylinder head mating surface of the cylinder head cover.
Apply Honda Bond A or equivalent to the gasket groove of the cylinder head cover.

Install the gasket into the groove.

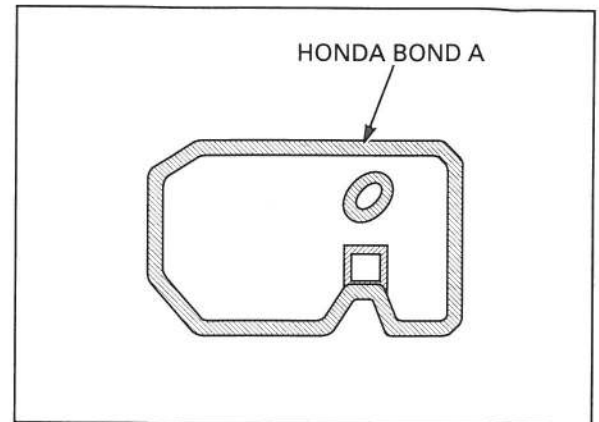

Clean the cylinder head cover mating surface of the cylinder head.

Install the front cylinder head cover to the front cylinder.

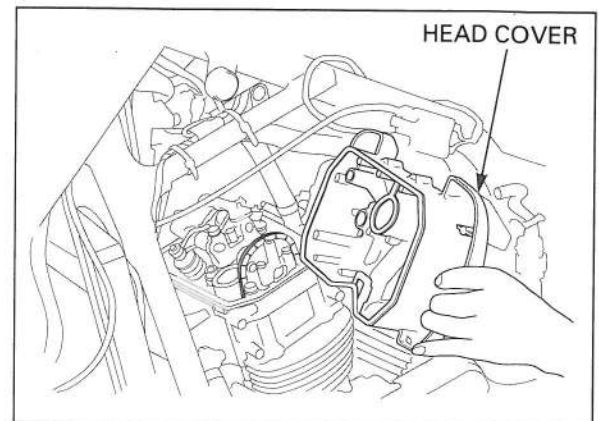

Apply engine oil to the rubber seals whole surface.
Install the rubber seals and washers.
Install and tighten the cylinder head cover bolts to the specified torque.

TORQUE: 10 N·m (1.0 kgf·m, 7 lbf·ft)

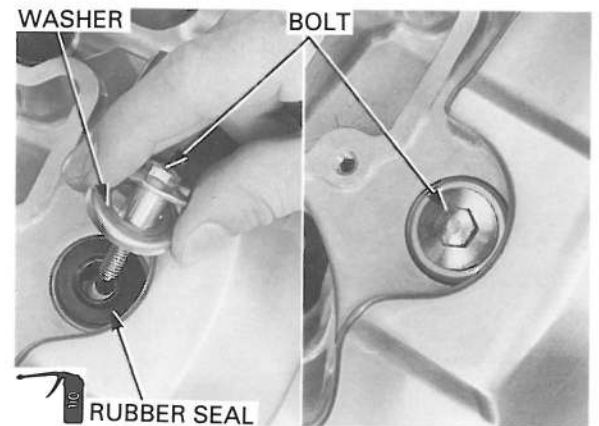

Install the thermostat housing to the frame.
Install and tighten the mounting bolt with the ground cable.

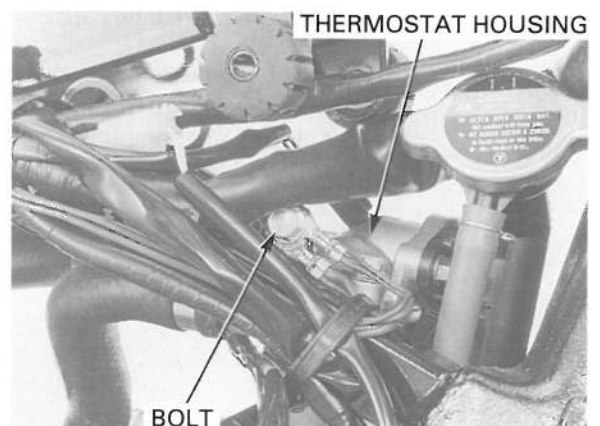

CYLINDER HEAD/VALVES

Install the each side cylinder fins and socket bolts.
Tighten the bolts to the specified torque.

TORQUE: 10 N·m (1.0 kgf·m, 7 lbf·ft)

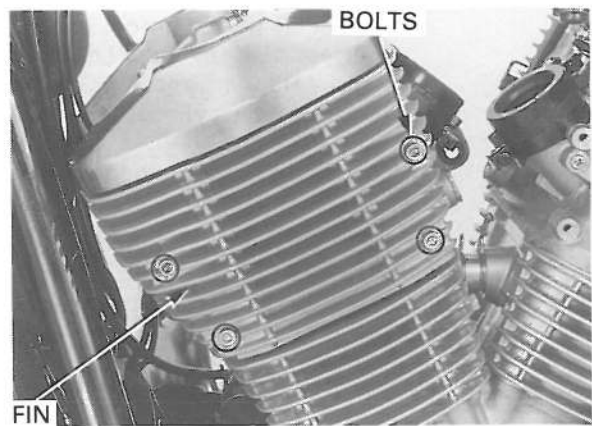

Install the cylinder head cover outer cover.
Install and tighten the bolts securely.

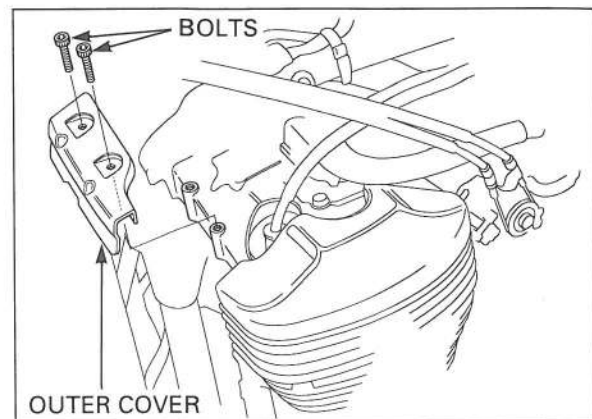

Install the sub-air cleaner housing.
Install and tighten the bolt securely.

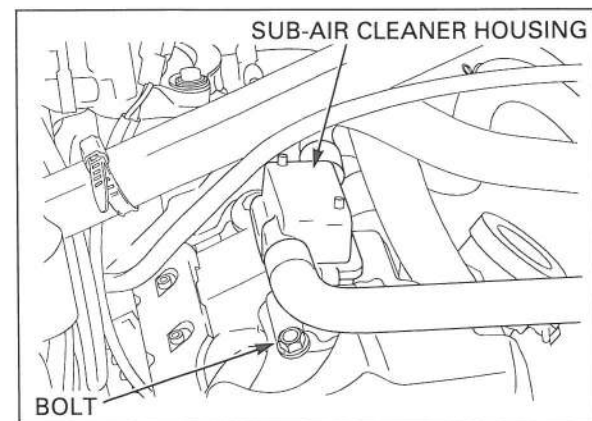

Connect the spark plug caps.

Install the following:

- Carburetors (page 5-20)
- Air cleaner chamber (page 5-7)
- Air cleaner housing (page 5-4)
- Fuel tank (page 2-4)
- Steering covers (page 2-3)

Fill the coolant (page 6-5).

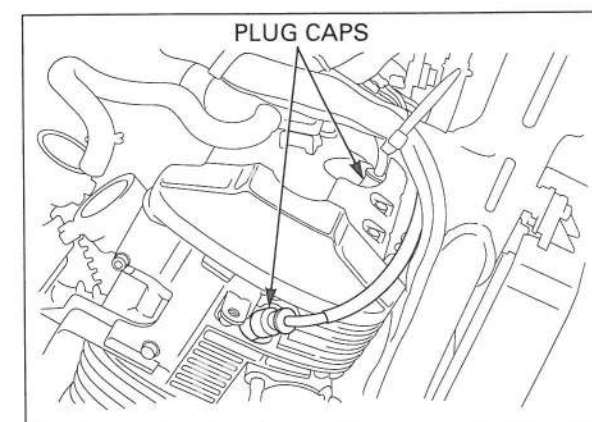

Clean the cylinder head cover mating surface of the cylinder head.

Install the rear cylinder head cover to the rear cylinder.

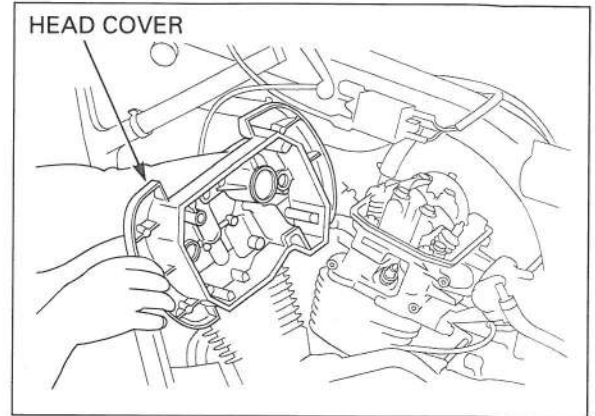

Apply engine oil to the rubber seals whole surface. Install the rubber seals and washers. Install and tighten the cylinder head cover bolts to the specified torque.

TORQUE: 10 N·m (1.0 kgf·m, 7 lbf·ft)

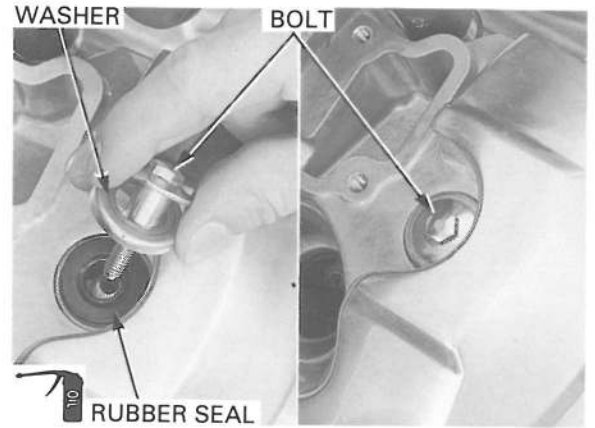

Install the removed side cylinder head fin and mounting socket bolts. Tighten the bolts to the specified torque.

TORQUE: 10 N·m (1.0 kgf·m, 7 lbf·ft)

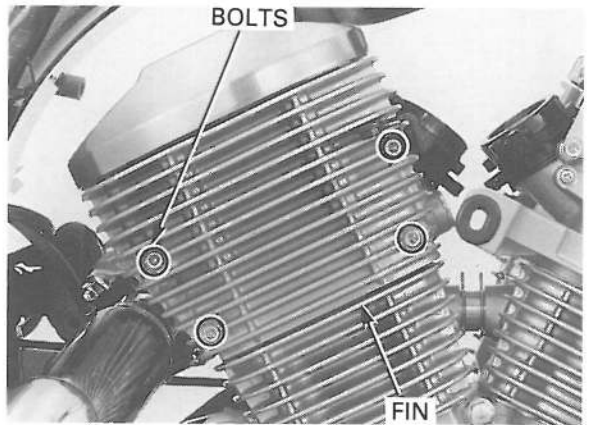

Install the cylinder head cover outer cover. Install the cable guide and tighten the bolts securely.

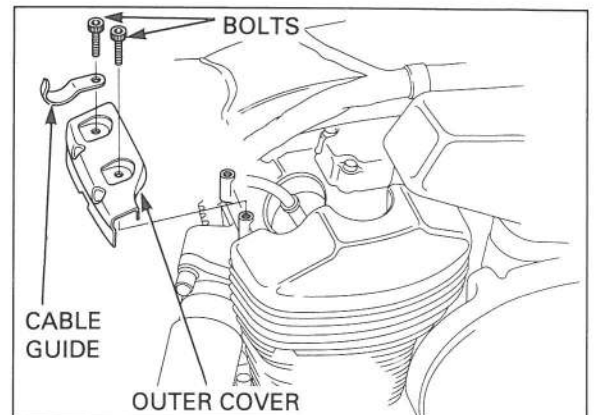

CYLINDER HEAD/VALVES

Install the new O-ring into the breather cover groove.
Install the breather cover and new bolts to the cylinder head cover.
Tighten the bolts to the specified torque.

TORQUE: 12 N·m (1.2 kgf·m, 9 lbf·ft)

Connect the spark plug cap.

Install the following:

- Carburetors (page 5-20)
- Air cleaner chamber (page 5-7)
- Air cleaner housing (page 5-4)
- Fuel tank (page 2-4)

Fill the coolant (page 6-5).

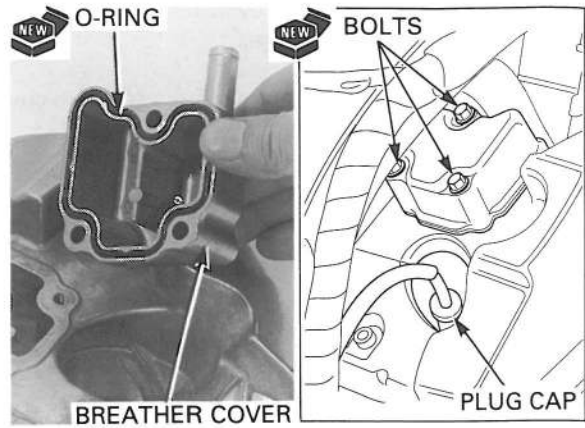

MEMO

CYLINDER/PISTON

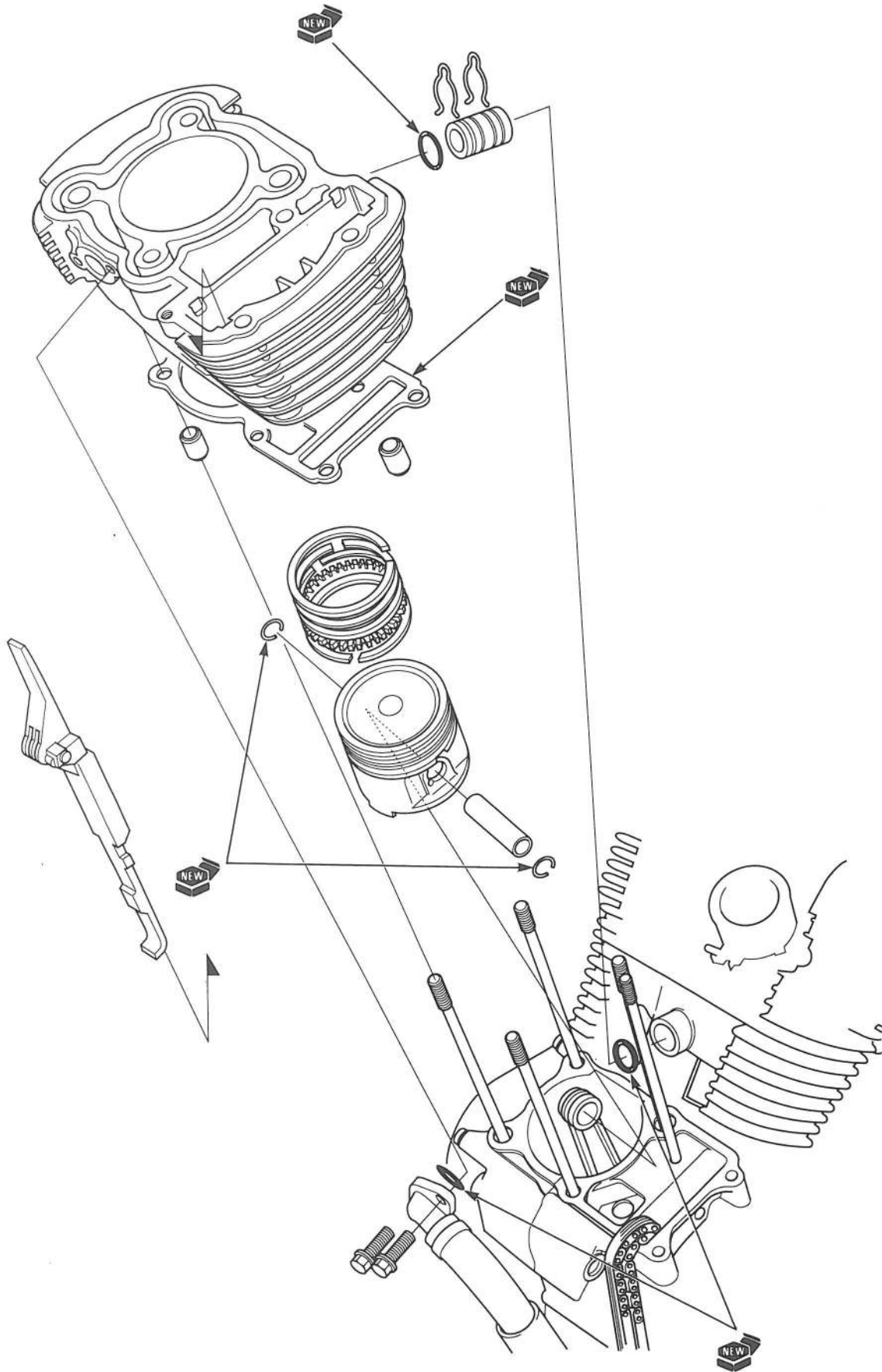

11. CYLINDER/PISTON

SERVICE INFORMATION	11-1	CRANKCASE STUD BOLT INSPECTION	11-8
TROUBLESHOOTING	11-2	PISTON INSTALLATION	11-8
CYLINDER REMOVAL	11-3	CYLINDER INSTALLATION	11-10
PISTON REMOVAL	11-5		

SERVICE INFORMATION

GENERAL

- The engine must be removed from the frame before servicing the cylinder and piston.
- Take care not to damage the cylinder wall and piston.
- Be careful not to damage the mating surfaces by using a screwdriver when disassembling the cylinder.
- Clean all disassembled parts with clean solvent and dry them using compressed air before inspection.
- When disassembling, mark and store the disassembled parts to ensure that they are reinstalled in their original locations.

SPECIFICATIONS

Unit: mm (in)

ITEM		STANDARD	SERVICE LIMIT	
Cylinder	I.D.	79.000 – 79.015 (3.1102 – 3.1108)	79.10 (3.114)	
	Out of round	—	0.06 (0.002)	
	Taper	—	0.06 (0.002)	
	Warpage	—	0.10 (0.004)	
Piston, piston rings	Piston mark direction	"IN" mark facing toward the intake side	—	
	Piston O.D.	78.97 – 78.99 (3.109 – 3.110)	78.90 (3.106)	
	Piston O.D. measurement point	7 – 17 mm (0.3 – 0.7 in) from bottom of skit	—	
	Piston pin bore I.D.	18.002 – 18.008 (0.7087 – 0.7090)	18.05 (0.711)	
	Piston pin O.D.	17.994 – 18.000 (0.7084 – 0.7087)	17.98 (0.708)	
	Piston-to-piston pin clearance	0.002 – 0.014 (0.0001 – 0.0006)	0.04 (0.002)	
	Piston ring-to-ring groove clearance	Top	0.025 – 0.055 (0.0010 – 0.0022)	0.08 (0.003)
		Second	0.015 – 0.045 (0.0006 – 0.0018)	0.07 (0.003)
	Piston ring end gap	Top	0.20 – 0.35 (0.008 – 0.014)	0.5 (0.02)
		Second	0.35 – 0.50 (0.014 – 0.020)	0.7 (0.03)
		Oil (side rail)	0.20 – 0.80 (0.008 – 0.031)	1.0 (0.04)
Piston ring mark	Top	"R" mark	—	
	Second	"RN" mark	—	
Cylinder-to-piston clearance		0.010 – 0.045 (0.0004 – 0.0018)	0.10 (0.004)	
Connecting rod small end I.D.		18.016 – 18.034 (0.7093 – 0.7100)	18.17 (0.711)	
Connecting rod-to-piston pin clearance		0.016 – 0.040 (0.0006 – 0.0016)	0.06 (0.002)	

11

TROUBLESHOOTING

Compression too low, hard starting or poor performance at low speed

- Leaking cylinder head gasket
- Worn, stuck or broken piston rings
- Worn or damaged cylinder and piston
- Loose spark plug

Compression too high, over heating or knocking

- Excessive carbon build-up in cylinder head or on top of piston

Abnormal noise

- Worn cylinder and piston
- Worn piston pin or piston pin hole
- Worn connecting rod small end

Excessive smoke

- Worn cylinder, piston and piston rings
- Improper installation of piston rings
- Scored or scratched piston or cylinder wall

CYLINDER REMOVAL

The front cylinder uses the same service procedure as the rear cylinder.

Remove the cylinder head (page 10-14).

Remove the joint clips.

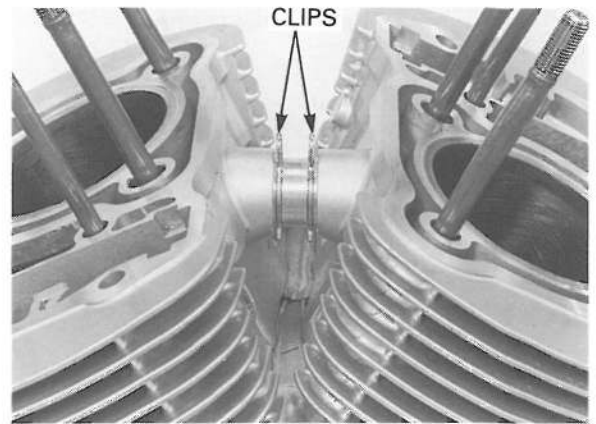

Slide the cylinder joint collar toward either the front or rear cylinder.

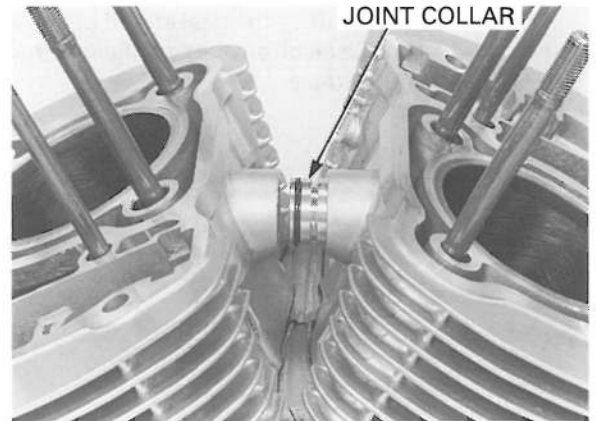

Front cylinder only: Remove the bolts, water hose joint and O-ring.

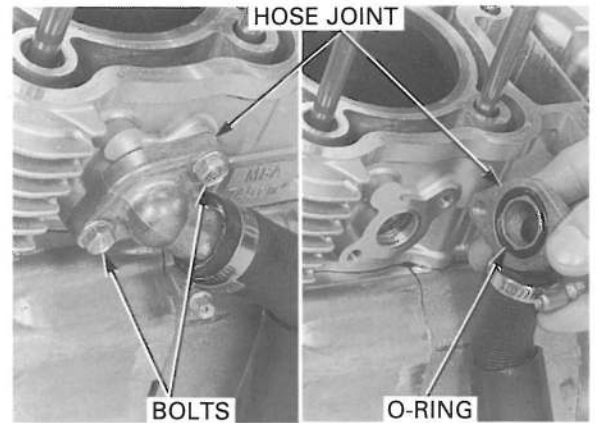

Remove the cylinder.

NOTE:

- Attach a piece of mechanic's wire to the cam chain to prevent it from being dropped into the crankcase.
- Be careful not to damage the mating surfaces by using a screwdriver when disassembling the cylinder.

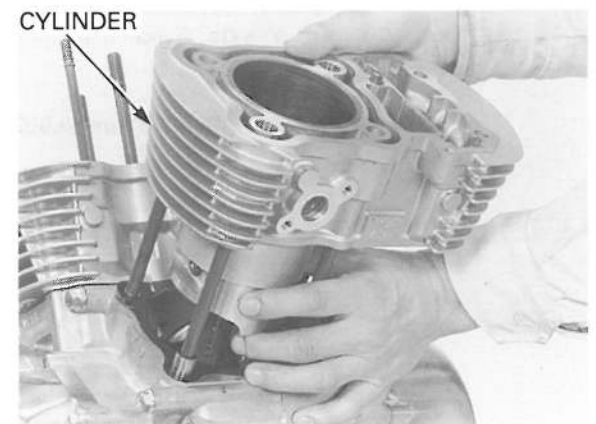

CYLINDER/PISTON

Remove the O-ring.

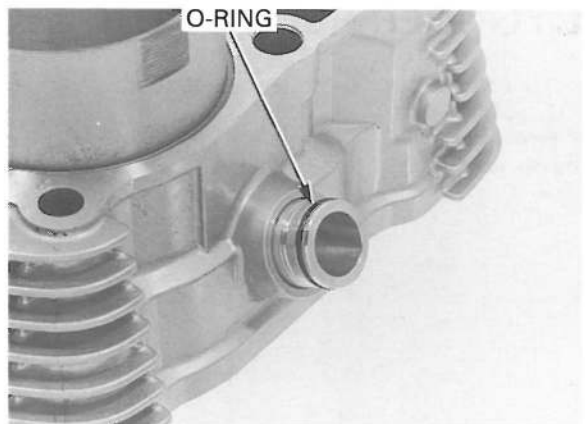

Be careful not to damage the gasket surface.

Remove the gasket and dowel pins.
Clean off any gasket material from the cylinder upper surface.

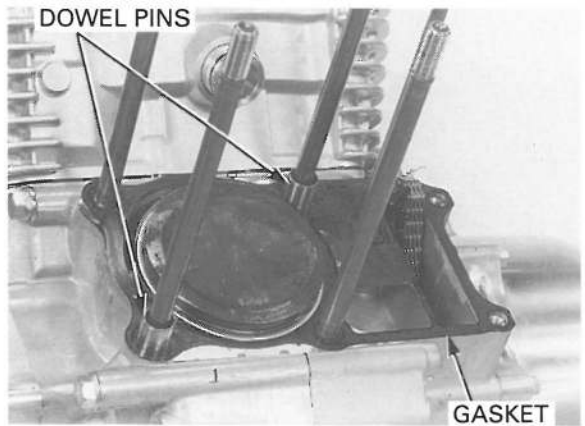

INSPECTION

Inspect the cylinder wall for scratches and wear.
Measure and record the cylinder I.D. at three levels in both the X and Y axes. Take the maximum reading to determine the cylinder wear.

SERVICE LIMIT: 79.10 mm (3.114 in)

Measure the cylinder for out of round at the three levels in an X and Y axis. Take the maximum reading to determine the out of round.

SERVICE LIMIT: 0.06 mm (0.002 in)

Measure the cylinder for taper at three levels in an X and Y axis. Take the maximum reading to determine the taper.

SERVICE LIMIT: 0.06 mm (0.002 in)

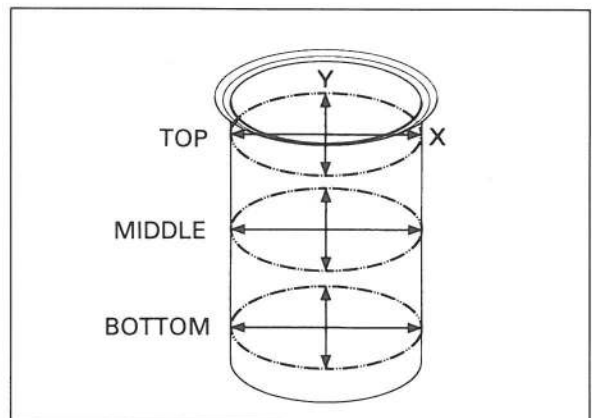
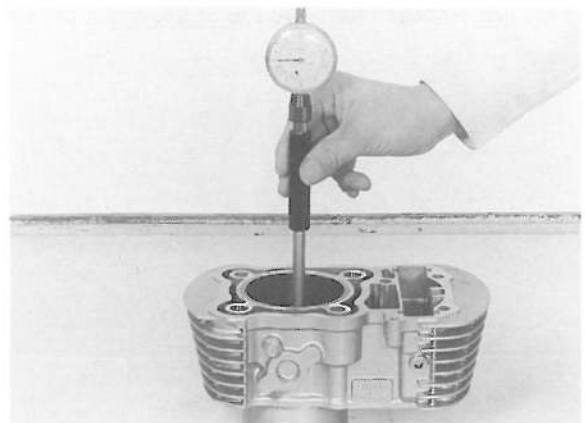

Check the cylinder for warpage by placing a straight edge and a feeler gauge.

SERVICE LIMIT: 0.10 mm (0.004 in)

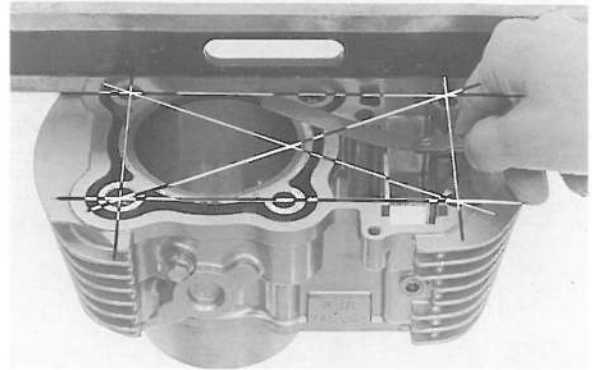

PISTON REMOVAL

NOTE:

Place a shop towel over the crankcase opening to prevent piston pin clips from falling into the crankcase.

The rear piston uses the same service procedure as the front piston.

Remove the piston pin clip, piston pin and piston.

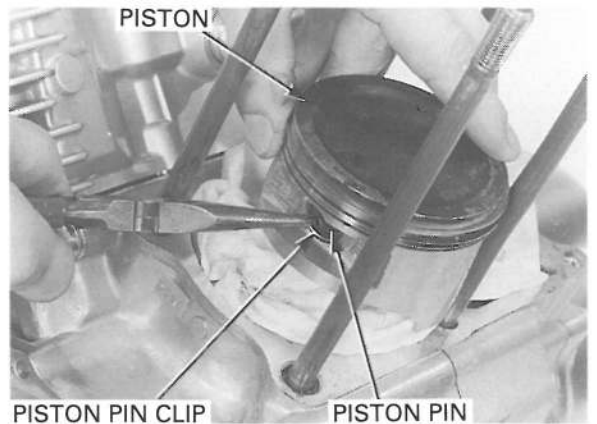

Remove the oil jets and O-rings.

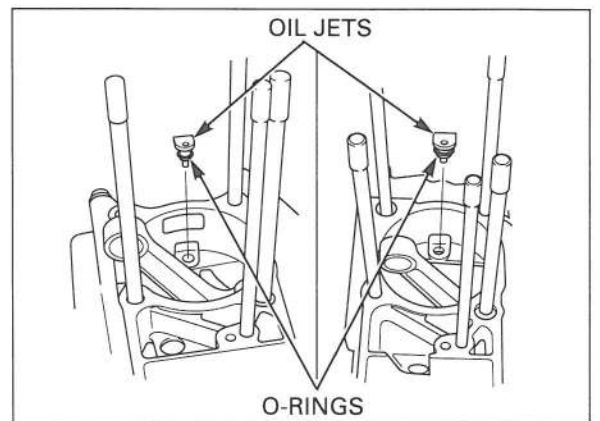

Spread each piston ring and remove it by lifting it up at a point just opposite the gap.

CAUTION:

- Do not damage the piston ring by spreading the ends too far.
- Be careful not to damage the piston during piston ring removal.

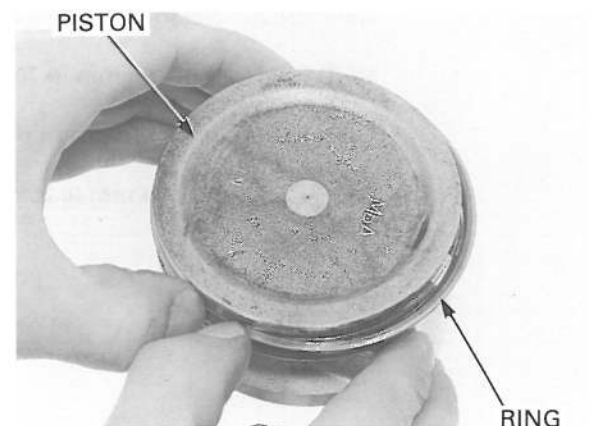

CYLINDER/PISTON

Clean carbon deposits from the piston.

NOTE:

Clean carbon deposits from the piston ring grooves with a ring that will be discarded. Never use the wire brush; it will scratch the groove.

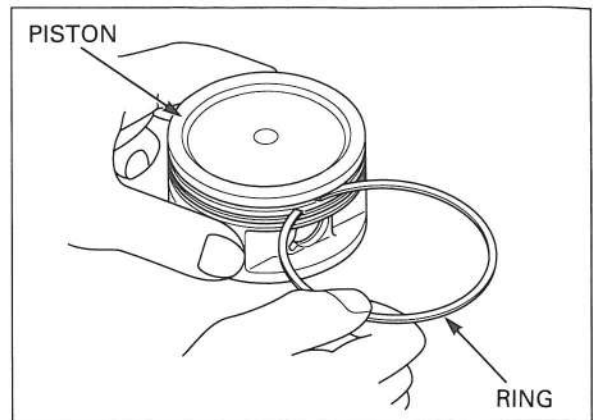

INSPECTION

Inspect the piston for cracks or other damage. Inspect the ring grooves for excessive wear and carbon build-up. Measure each piston O.D..

NOTE:

Take measurements 7 – 17 mm (0.3 – 0.7 in) from the bottom, and 90° to the piston pin hole.

SERVICE LIMIT: 78.90 mm (3.106 in)

Calculate the piston-to-cylinder clearance. Take the maximum reading to determine the clearance (Cylinder I.D.: 11-4).

SERVICE LIMIT: 0.10 mm (0.004 in)

Measure each piston pin hole I.D. in an X and Y axis. Take the maximum reading to determine I.D..

SERVICE LIMIT: 18.05 mm (0.711 in)

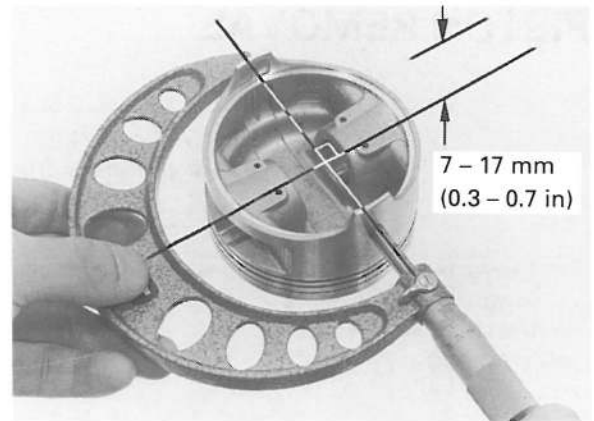

Measure the piston pin O.D. at three points.

SERVICE LIMIT: 17.98 mm (0.708 in)

Calculate the piston-to-piston pin clearance.

SERVICE LIMIT: 0.04 mm (0.002 in)

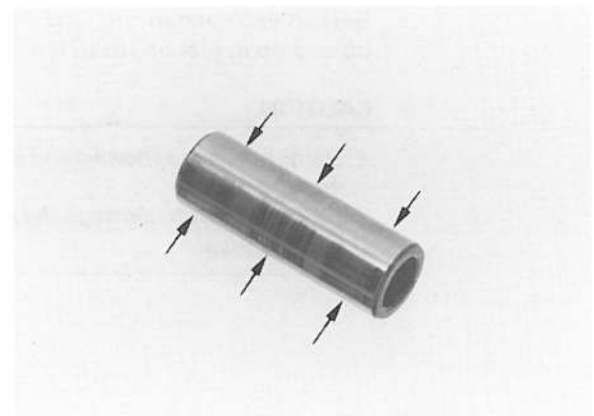

Measure the connecting rod small end I.D.

SERVICE LIMIT: 18.07 mm (0.711 in)

Calculate the connecting rod small end-to-piston pin clearance.

SERVICE LIMIT: 0.06 mm (0.002 in)

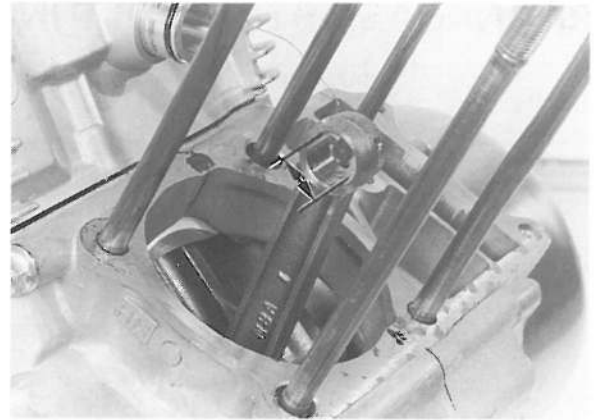

Always replace the piston rings as a set.

Inspect the piston ring, and replace them if they are worn.

Reinstall the piston rings (page 11-8) into the piston grooves.

Push in the ring until the outer surface of the piston ring is nearly flush with the piston and measure the clearance using a feeler gauge.

SERVICE LIMIT:

Top: 0.08 mm (0.003 in)

Second: 0.07 mm (0.003 in)

Using a piston, push the ring securely into the cylinder and measure the end gap using a feeler gauge.

SERVICE LIMIT:

Top: 0.5 mm (0.02 in)

Second: 0.7 mm (0.03 in)

Oil : 1.0 mm (0.04 in)

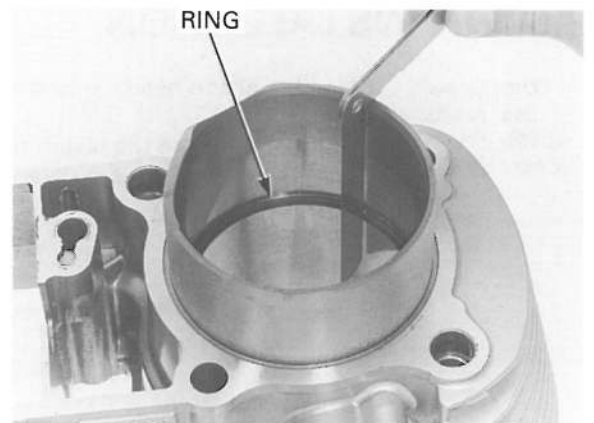
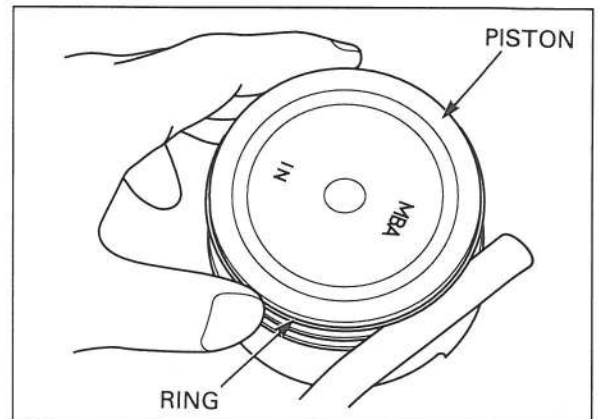

Check the oil jet for clogging.

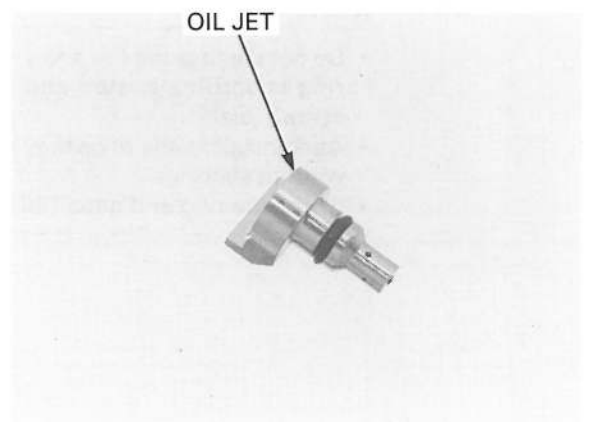

CRANKCASE STUD BOLT INSPECTION

Check the stud bolts for looseness. If the stud bolts are loose or need to be replaced, remove the stud bolts, apply engine oil to the threads, and tighten the stud bolt securely.

NOTE:

Install the stud bolts with its tab side facing the cylinder head side.

After installing, be sure to measure the length from the top of each stud to crankcase surface.

STANDARD LENGTH:

- 8 X 189 mm: 186 mm (7.3 in)
- 10 X 177 mm: 169 mm (6.6 in)
- 12 X 177 mm: 169 mm (6.6 in)

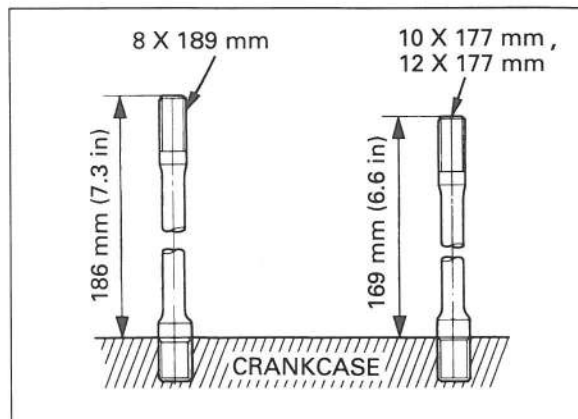
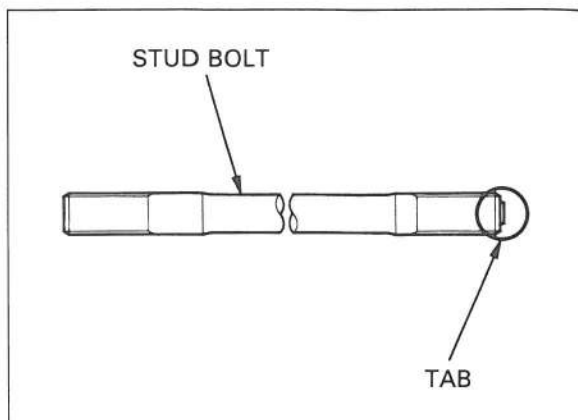

PISTON INSTALLATION

The rear piston uses the same service procedure as the front piston.

Clean the piston heads, ring lands and skirts.

Apply engine oil to the piston rings outer surfaces. Carefully install the piston rings onto the piston with their markings facing up.

CAUTION:

- Do not damage the piston ring by spreading the ends too far.
- Be careful not to damage the piston during piston ring installation.

NOTE:

- Do not confuse the top and second rings: The top ring is chrome-coated and second ring is not coated (black).
- After installing the rings they should rotate freely, without sticking.
- Space the ring end gaps 120 degrees apart.

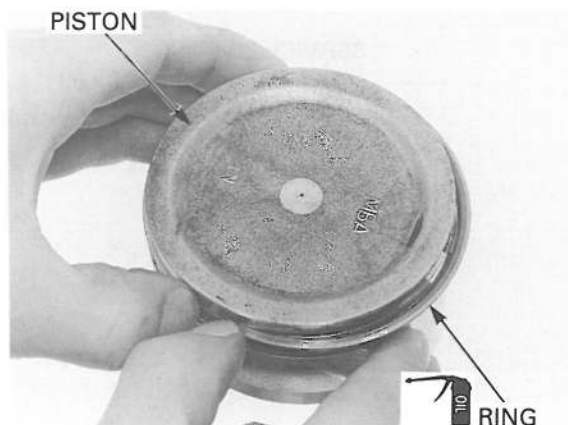

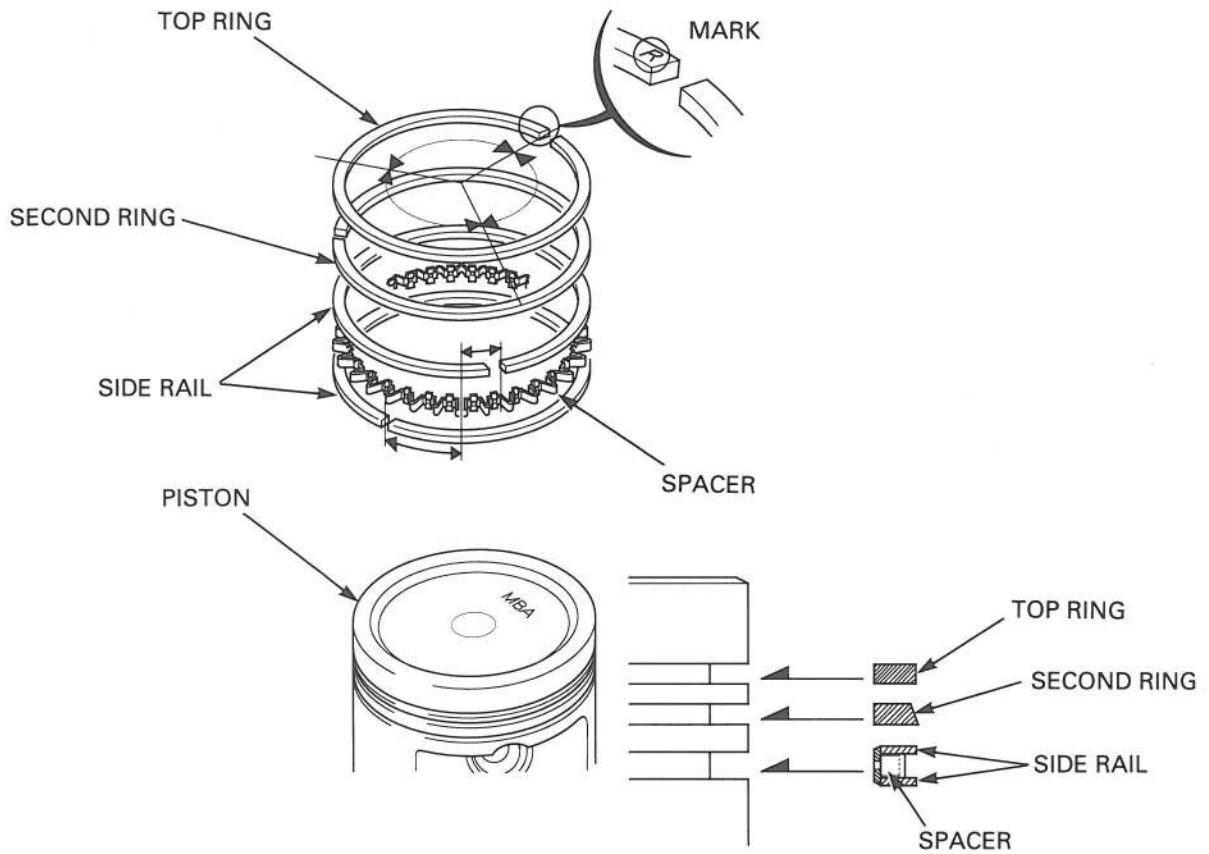

Apply engine oil to the new O-ring and install it to the oil jet.
Securely install the oil jet onto the crankcase.

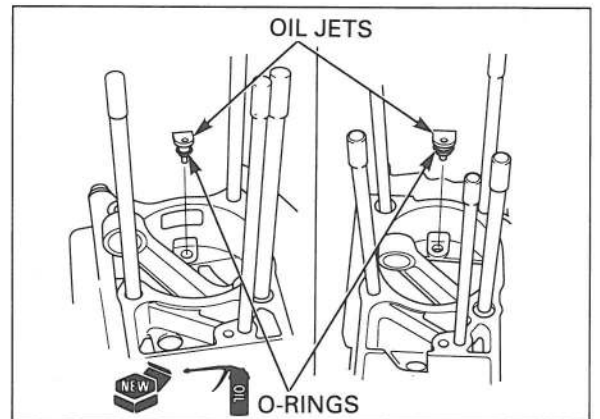

NOTE:

When cleaning the cylinder mating surface, place a shop towel over the cylinder opening to prevent dust or dirt from entering the engine.

Clean any gasket material from the cylinder mating surfaces of the crankcase.

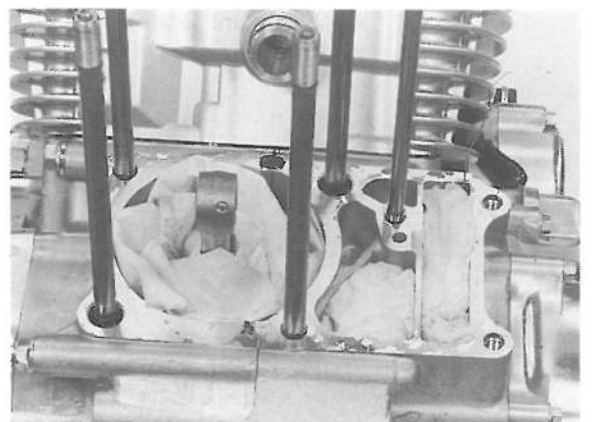

CYLINDER/PISTON

NOTE:

Place a shop towel over the crankcase opening to prevent piston pin clips from falling into the crankcase.

Apply molybdenum disulfide oil to the connecting rod small end inner surface.
Apply engine oil to the piston pin outer surface.
Install the piston with its "IN" mark facing the intake side.
Install the piston pin.
Install the new piston pin clips.

CAUTION:

Always use new piston pin clips. Reinstalling used piston pin clips may lead to serious engine damage.

NOTE:

- Set the piston pin clip in the groove properly.
- Do not align the clip's end gap with the piston cutout.

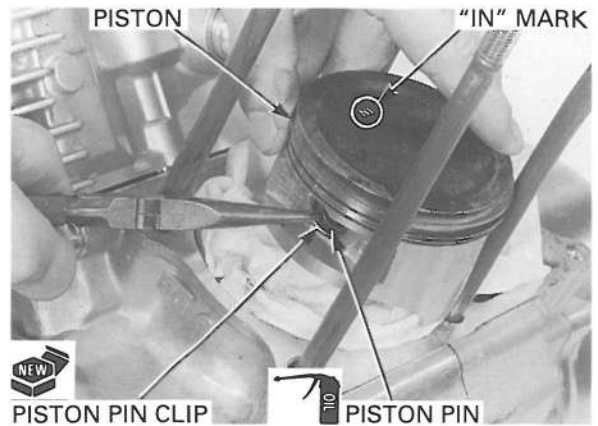

CYLINDER INSTALLATION

NOTE:

When cleaning the cylinder mating surface, place a shop towel over the cylinder opening to prevent dust or dirt enter the engine.

The rear cylinder uses the same service procedure as the front cylinder.

Install the dowel pins and new gasket.

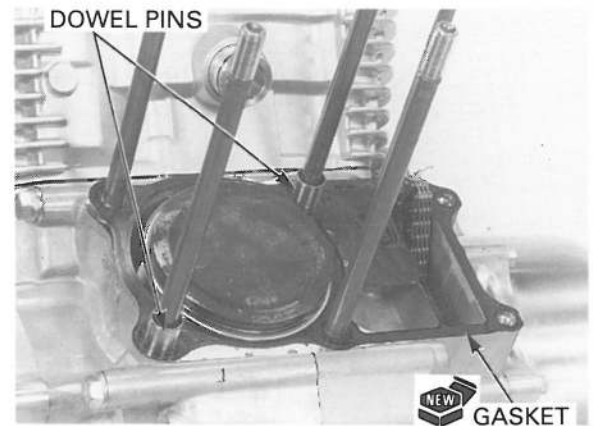

Apply coolant to the new O-ring and install it to the water joint of the cylinder.

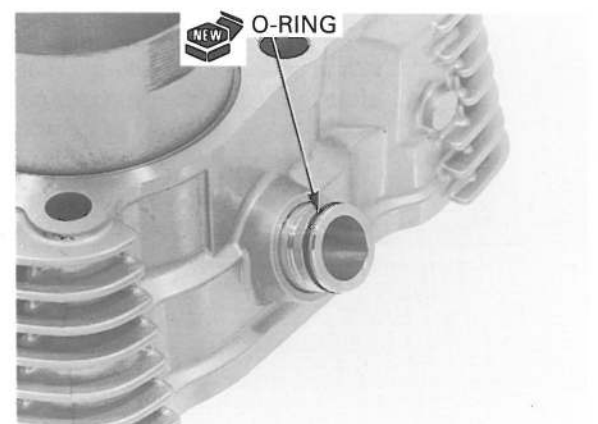

Apply engine oil to the cylinder wall, piston outer surfaces and piston rings.

CAUTION:

Be careful not to damage the piston rings and cylinder walls.

Route the cam chain through the cylinder. Install the cylinder over the piston rings by hand while compressing the piston rings.

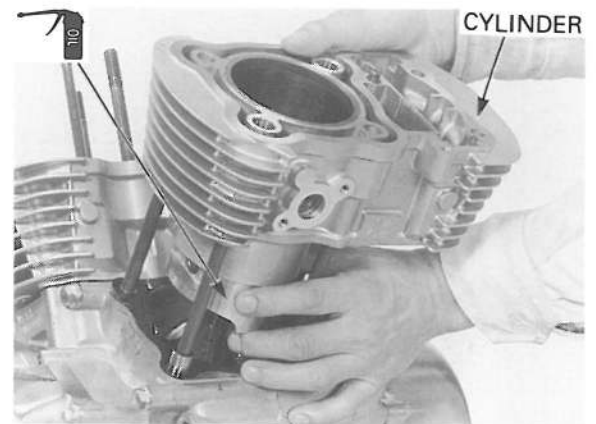

Slide the cylinder joint collar to the its original position.

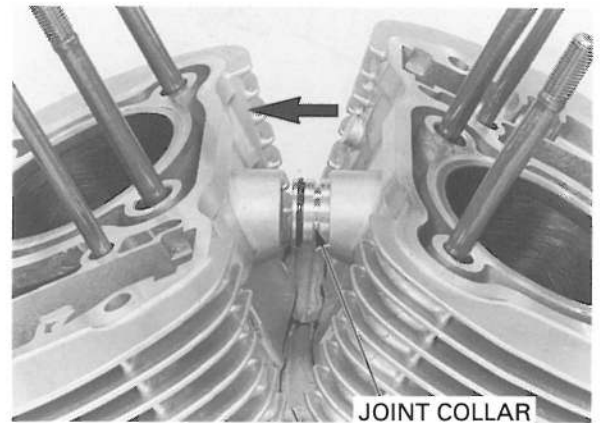

Install the joint collar clips to the groove on the water joint of the cylinder.

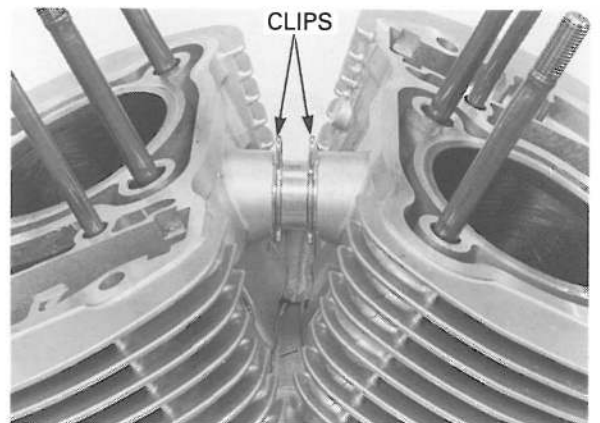

Apply coolant to the new O-ring and install it to the groove on the water hose joint of the front cylinder (front cylinder only).

Install and tighten the hose joint bolts securely (front cylinder only).

NOTE:

If the water hose was removed, connect the water hose by aligning the white paint on the hose with the boss on the water pipe.

Install the cylinder head (page 10-24).

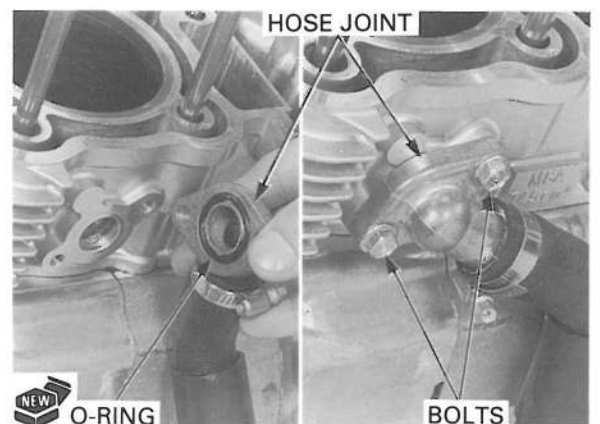

CRANKSHAFT/TRANSMISSION

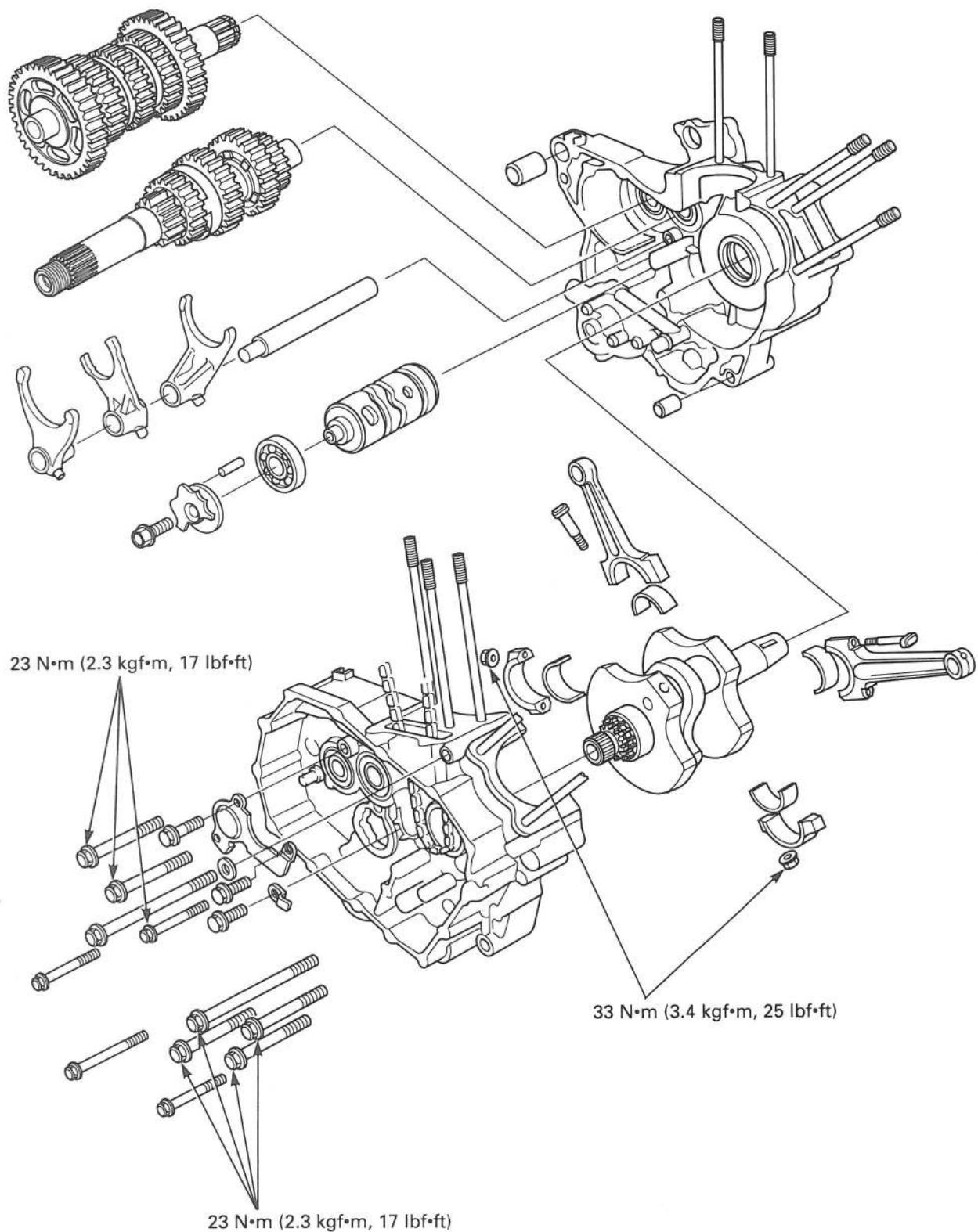

12. CRANKSHAFT/TRANSMISSION

SERVICE INFORMATION	12-2	TRANSMISSION	12-12
TROUBLESHOOTING	12-3	CRANKCASE BEARING REPLACEMENT	12-20
CRANKCASE SEPARATION	12-4	CRANKCASE ASSEMBLY	12-22
CRANKSHAFT/CONNECTING ROD	12-6		

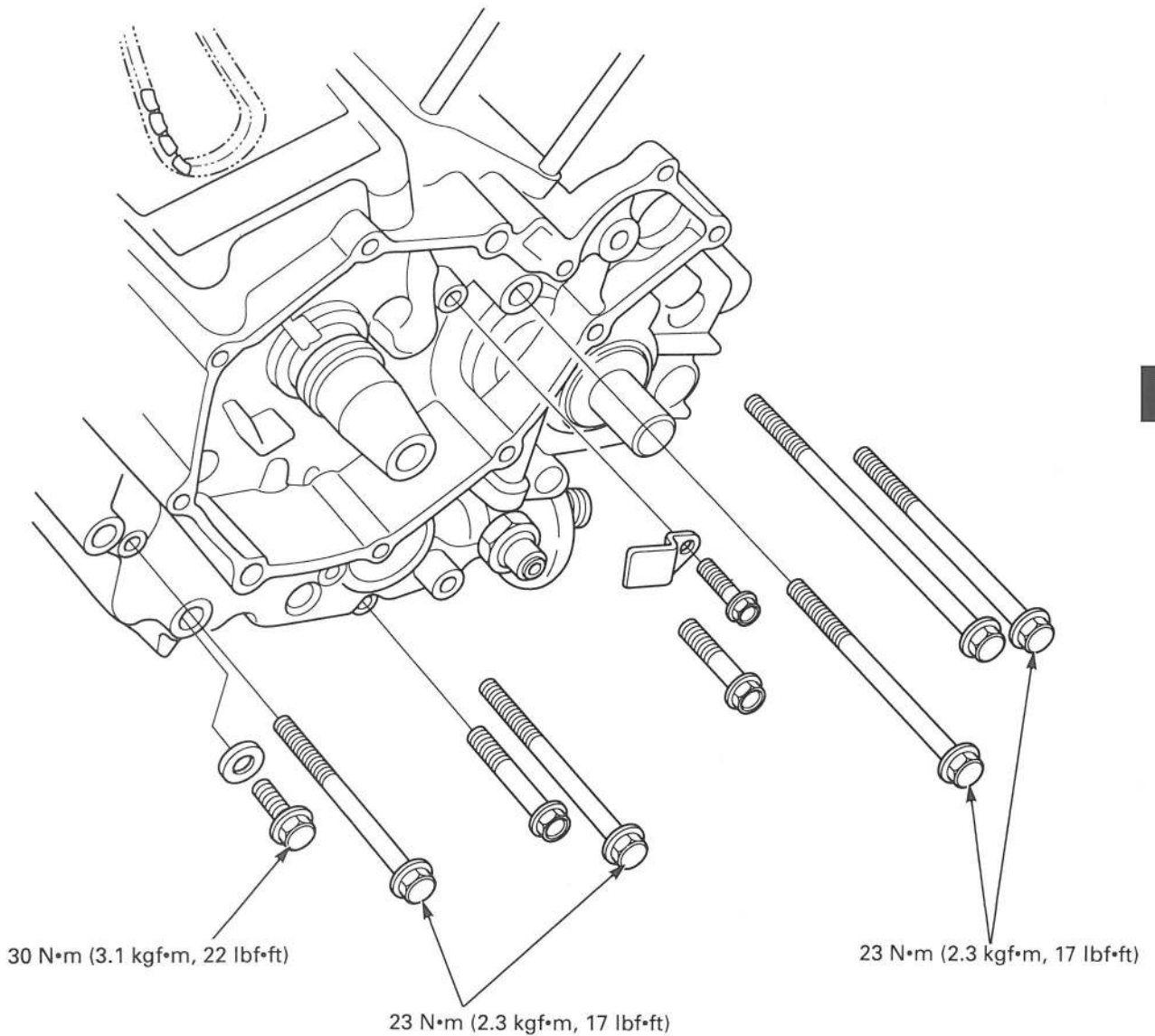

SERVICE INFORMATION

GENERAL

- The crankcase halves must be separated to service the crankshaft, connecting rod and transmission (including the shift fork and shift drum). To service these parts, the engine must be removed from the engine (Section 7).
- The following parts must be removed before separating the crankcase:
 - Oil filter (Section 3)
 - Water pump (Section 6)
 - Cylinder head (Section 10)
 - Cylinder, piston (Section 11)
 - Clutch, gearshift linkage and primary drive gear (Section 8)
 - Alternator, flywheel (Section 9)
 - Starter motor (Section 18)
 - Neutral switch, oil pressure switch (Section 19)
- Be careful not to damage the crankcase mating surface.
- When disassembling, mark and store the disassembled parts to ensure that they are reinstalled in their original locations.
- Connecting rod bearing inserts are select fitted and are identified by color code. Select the replacement bearings using the selection tables. After installing new bearings, recheck them with plastigauge to verify correct clearance.
- Clean and apply sealant to the crankcase mating surfaces. Wipe off excess sealant thoroughly.

SPECIFICATIONS

Unit: mm (in)

ITEM		STANDARD	SERVICE LIMIT	
Crankshaft	Side clearance	0.05 – 0.20 (0.002 – 0.008)	0.30 (0.012)	
	Runout	—	0.03 (0.001)	
	Crank pin oil clearance	0.028 – 0.052 (0.0011 – 0.0020)	0.07 (0.003)	
	Main journal oil clearance	0.030 – 0.046 (0.0012 – 0.0018)	0.07 (0.003)	
Transmission	Gear I.D.	M3, M5	28.000 – 28.021 (1.1024 – 1.1032)	28.04 (1.104)
		C1, C2, C4	31.000 – 31.025 (1.2204 – 1.2215)	31.05 (1.222)
	Bushing O.D.	M3, M5	27.959 – 27.980 (1.1007 – 1.1016)	27.94 (1.100)
		C1, C2, C4	30.950 – 30.975 (1.2185 – 1.2195)	30.93 (1.218)
	Bushing I.D.	M3	25.000 – 25.021 (0.9843 – 0.9851)	25.04 (0.986)
		C2	27.995 – 28.016 (1.1021 – 1.1030)	28.04 (1.104)
	Gear-to-bushing clearance	M3, M5	0.020 – 0.062 (0.0008 – 0.0024)	0.10 (0.004)
		C1, C2, C4	0.025 – 0.075 (0.0010 – 0.0030)	0.11 (0.004)
	Mainshaft O.D.	M3 bushing	24.972 – 24.993 (0.9831 – 0.9840)	24.95 (0.982)
		Case journal A	19.980 – 19.993 (0.7866 – 0.7871)	19.96 (0.786)
		Case journal B	21.967 – 21.980 (0.8648 – 0.8654)	21.94 (0.864)
	Countershaft O.D.	C2 bushing	27.967 – 27.980 (1.1011 – 1.1016)	27.95 (1.100)
		Case journal A	27.972 – 27.990 (1.1013 – 1.1020)	27.95 (1.100)
		Case journal B	19.980 – 19.993 (0.7866 – 0.7871)	19.96 (0.786)
Bushing-to-shaft clearance	M3	0.007 – 0.049 (0.0003 – 0.0019)	0.08 (0.003)	
	C2	0.015 – 0.049 (0.0006 – 0.0019)	0.08 (0.003)	
Shift fork, fork shaft	Fork	I.D.	13.000 – 13.021 (0.5118 – 0.5126)	13.04 (0.513)
		Claw thickness	5.93 – 6.00 (0.233 – 0.236)	5.6 (0.22)
	Fork shaft O.D.		12.966 – 12.984 (0.5105 – 0.5112)	12.90 (0.508)
Shift drum O.D. (at left side journal)			11.966 – 11.984 (0.4711 – 0.4718)	11.94 (0.470)

TORQUE VALUES

Crankcase 8 mm bolt	23 N•m (2.3 kgf•m, 17 lbf•ft)	
Connecting rod bearing cap nut	33 N•m (3.4 kgf•m, 25 lbf•ft)	Apply oil to the threads and seating surface

TOOLS

Attachment, 42 × 47 mm	07746-0010300	
Attachment, 52 × 55 mm	07746-0010400	
Pilot, 20 mm	07746-0040500	
Pilot, 25 mm	07746-0040600	
Pilot, 22 mm	07746-0041000	
Driver	07749-0010000	
Bearing remover set	07936-3710001	Not available in U.S.A. or 07936-371020A (U.S.A. only) or 07936-3710200
– Remover weight	07741-0010201	
– Remover handle	07936-3710100	
– Bearing remover set	07936-3710600	

TROUBLESHOOTING

Excessive noise

- Worn connecting rod big end bearing
- Bent connecting rod
- Worn crankshaft main bearing
- Worn transmission gear

Hard to shift

- Improper clutch adjustment
- Improper clutch operation
- Bent shift fork
- Bent shift fork shaft
- Bent shift spindle
- Damaged shift drum cam grooves
- Incorrect transmission oil weight

Transmission jumps out of gear

- Worn gear dogs or slots
- Bent fork shaft
- Broken shift drum stopper
- Worn or bent shift forks
- Broken shift linkage return spring

CRANKCASE SEPARATION

Remove the engine from the frame (Section 7).

Refer to Service Information (page 12-1) for removal of necessary parts before disassembling the crankcase.

Remove the bolt and front cam chain tensioner set plate.

Remove the front cam chain from the crankshaft.

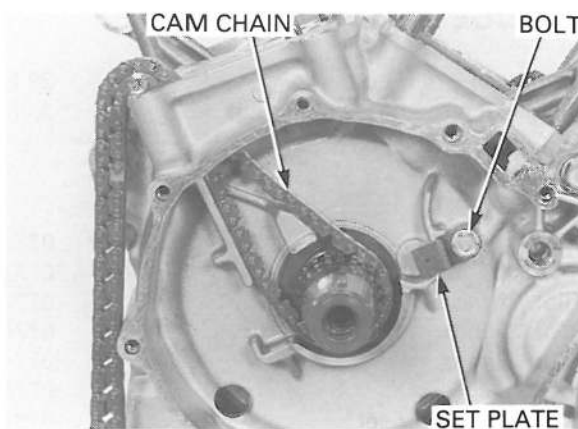

Remove the bolt and rear cam chain tensioner set plate.

Remove the rear cam chain.

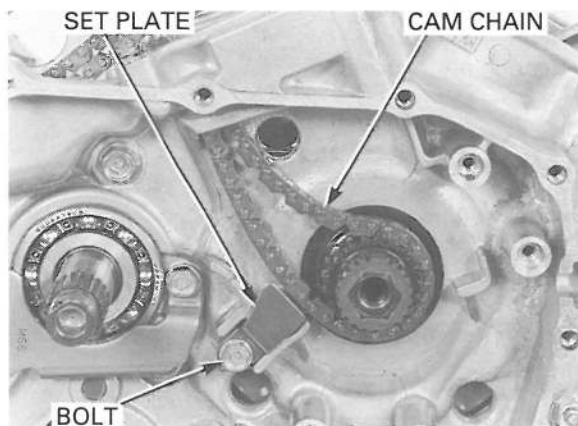

Remove the mainshaft bearing set plate by removing the bolts.

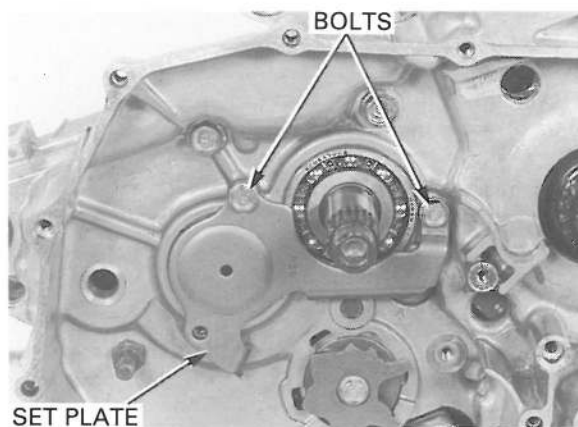

Turn the shift drum until shift cam plate is positioned shown.

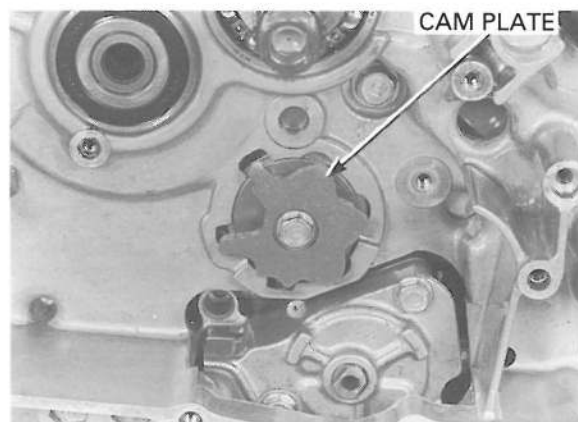

Remove the left crankcase bolts.

NOTE:

- Loosen the 6 mm bolts first, then 8 mm bolts.
- Loosen the left crankcase bolts in a crisscross pattern in several steps.

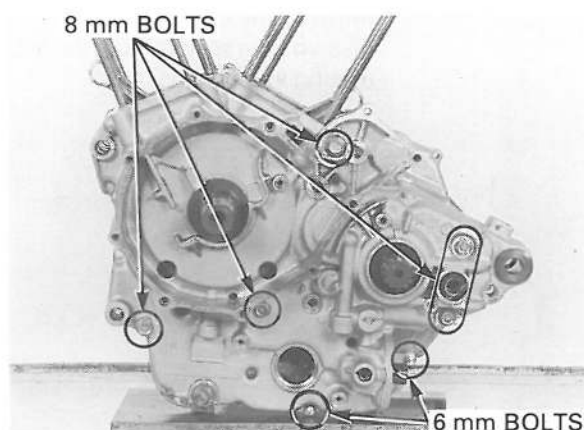

Remove the right crankcase bolts.

NOTE:

- Loosen the 6 mm bolts first, then 8 mm bolts.
- Loosen the right crankcase bolts in a crisscross pattern in several steps.

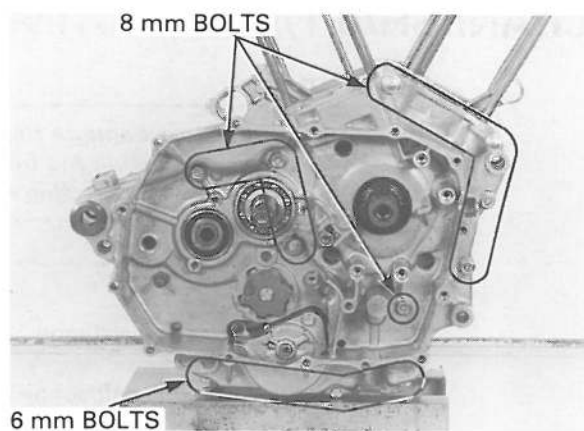

Place the crankcase with the left crankcase down and remove the right crankcase.

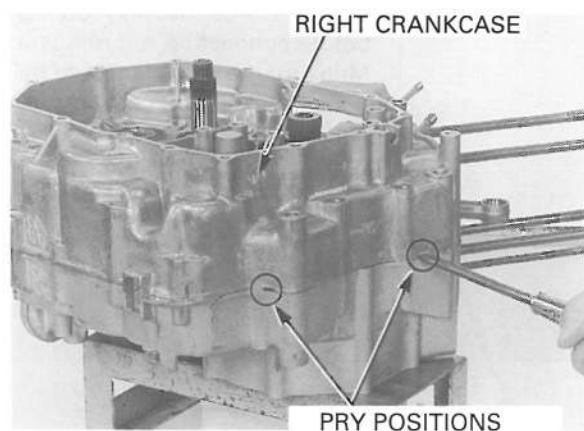

NOTE:

- Separate the right crankcase from the left crankcase while prying at the points as shown.
- Separate the right crankcase from the left crankcase while tapping them at several locations with a soft hammer.

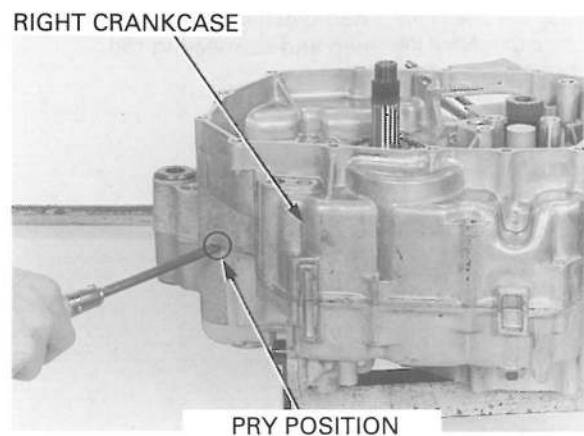

CRANKSHAFT/TRANSMISSION

Remove the dowel pins.
Clean off the sealant from the left and right crankcase mating surfaces.

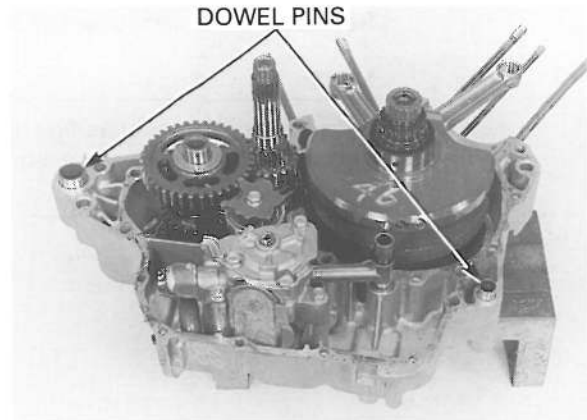

CRANKSHAFT/CONNECTING ROD

CAUTION:

Be careful not to damage the crankshaft main bearing and connecting rod bearing while servicing the crankshaft/connecting rod.

REMOVAL

Separate the crankcase (page 12-4).

Remove the crankshaft/connecting rod from left crankcase.

Inspect the connecting rod big end side clearance before connecting rod removal. Measure the side clearance by inserting the feeler gauge between the crankshaft and connecting rod big end as shown.

STANDARD: 0.30 mm (0.012 in)

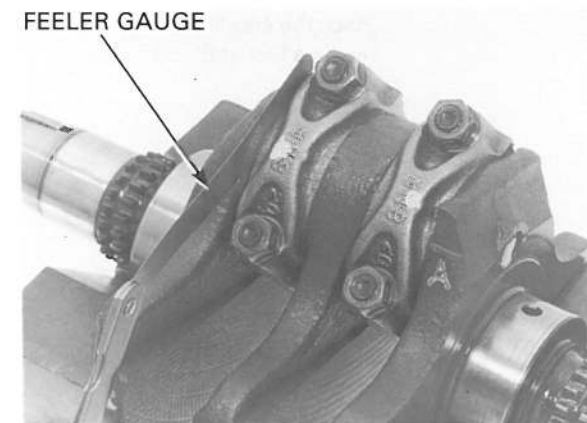
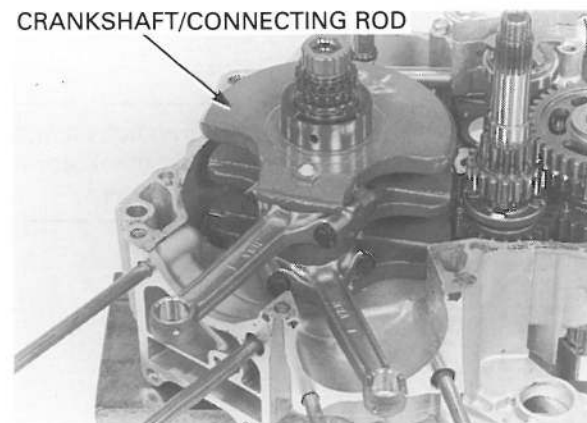

Tap the side of the cap lightly if the bearing cap is hard to remove.

Remove the connecting rod bearing cap nuts, bearing cap and connecting rod.

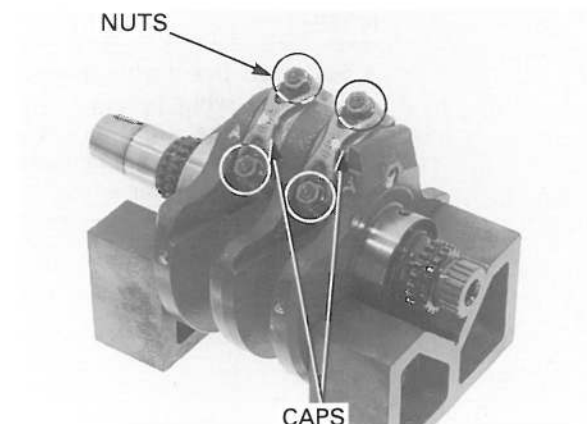

Mark the bearing caps, bearings and connecting rod as you remove them to indicate the correct cylinder and position on the crank pins for reassembly.

Connecting rod small end inspection (page 11-7).

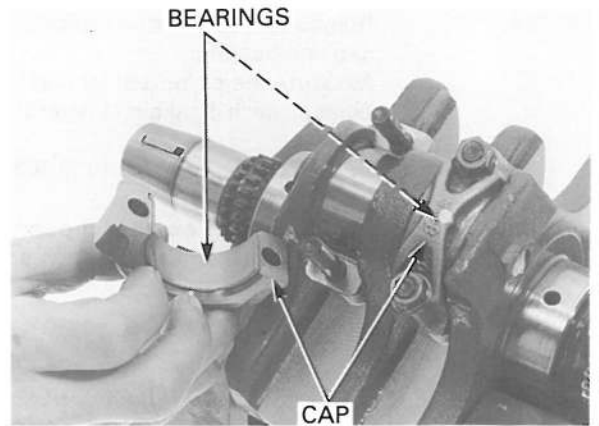

CONNECTING ROD BEARING INSPECTION

Inspect the bearing inserts for unusual wear, damage or peeling and replace if necessary.

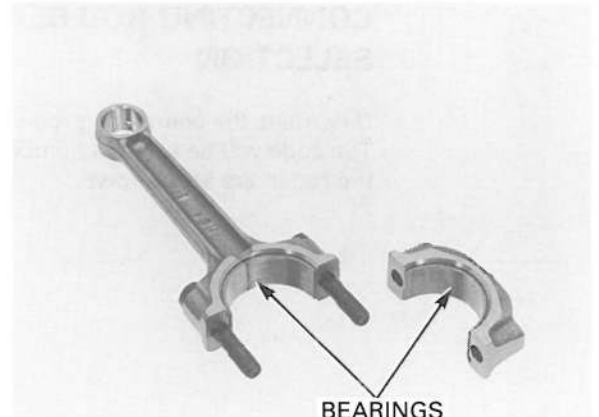

CRANKPIN OIL CLEARANCE

Do not rotate the crankshaft during inspection.

Clean off any oil from the connecting rod bearing inserts and crank pin. Put a strip of plastigauge on each crank pin avoiding oil hole.

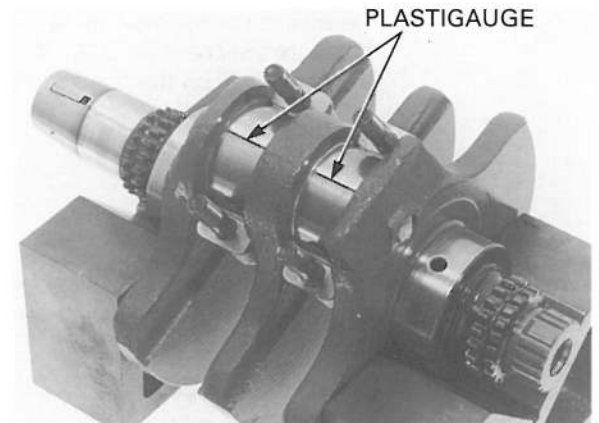

Install the connecting rod bearing and bearing cap to the original location. Install and tighten the connecting rod bearing cap nuts in a crisscross pattern in several steps.

TORQUE: 33 N·m (3.4 kgf·m, 25 lbf·ft)

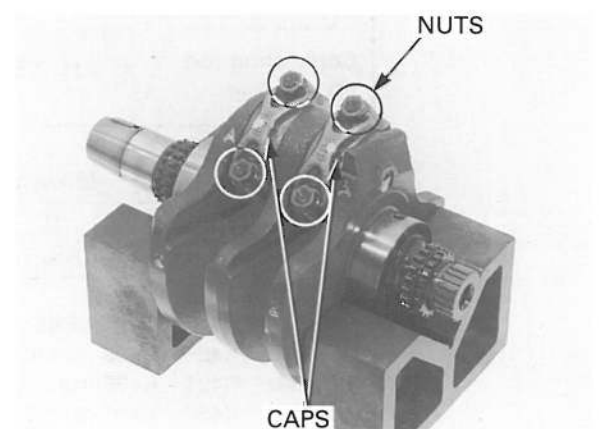

CRANKSHAFT/TRANSMISSION

Remove the connecting rod bearing cap nuts, bearing cap and bearing.

Measure the compressed plastigauge at its widest point on each crankpin to determine the oil clearance.

SERVICE LIMIT: 0.07 mm (0.003 in)

If the clearance exceeds the service limit, select the correct replacement bearings as follows.

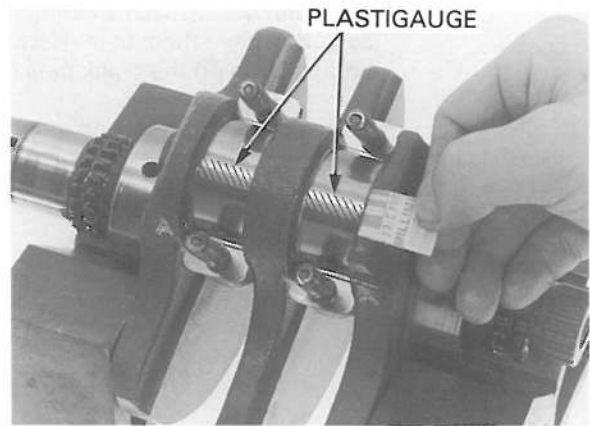

CONNECTING ROD BEARING SELECTION

Determine the connecting rod I.D. number. The code will be either a number 1 or 2 located on the rod in the area shown.

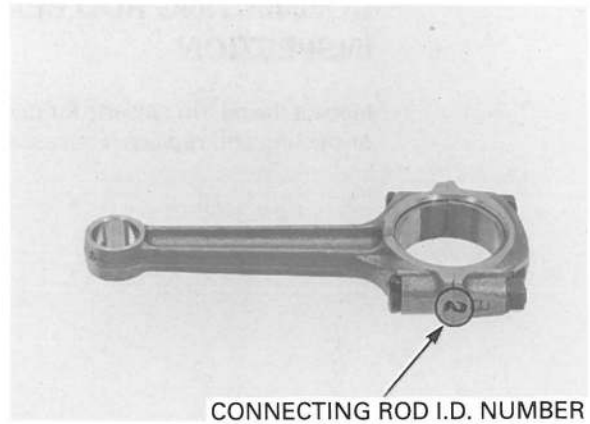

Determine the corresponding crankpin O.D. code (or measure the crankpin O.D.), the code will be either a letter A or B on the crank weight.

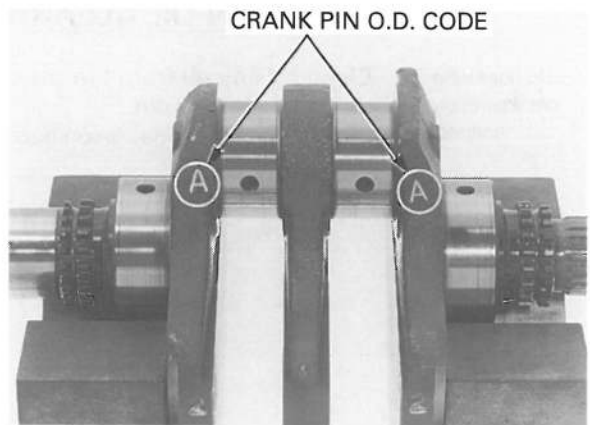

Cross reference the crankpin and connecting rod codes to determine the replacement bearing collar.

Unit: mm (in)

Crankpin O.D. code		A	B
		39.982 - 39.990 (1.5741 - 1.5744)	39.974 - 39.981 (1.5738 - 1.5741)
Connecting rod I.D. number	1	C (Brown)	B (Black)
	2	B (Black)	A (Blue)

BEARING INSERT THICKNESS:

A (Blue): 1.495 - 1.499 mm (0.0589 - 0.0590 in)

B (Black): 1.491 - 1.495 mm (0.0587 - 0.0589 in)

C (Brown): 1.487 - 1.491 mm (0.0585 - 0.0587 in)

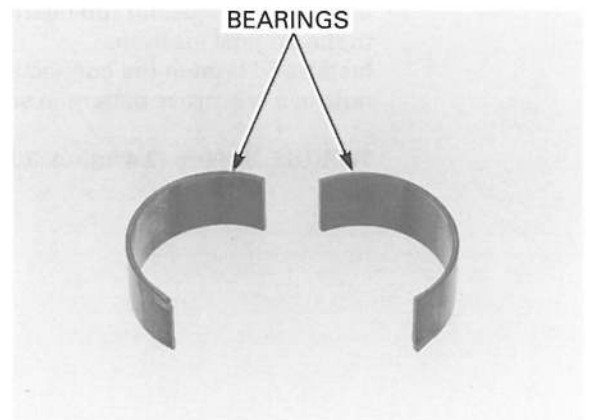

'98 - 2000: **CONNECTING ROD/CRANKSHAFT SELECTION**

Connecting rod and crankshaft are select fitted. Record the connecting rod weight code (A, B or C). Record the crankshaft weight code (L, R or No code). If the connecting rod and/or crankshaft are replaced, select them with the following fitting table.

NOTE:

The "○" mark in the table indicates that mating is possible in the crossed codes.

Front connecting rod weight code	A	B	C
Rear connecting rod weight code			
A	*	○	○
B	○	○	○
C	○	○	**

CAUTION:

For selecting crankshaft weight.

- Select "L" crankshaft weight, if the front rod and rear rod have code A (*).
- Select "R" crankshaft weight, if the front rod and rear rod have code C (**).
- Select crankshaft weight with no code, other than the above two cases.

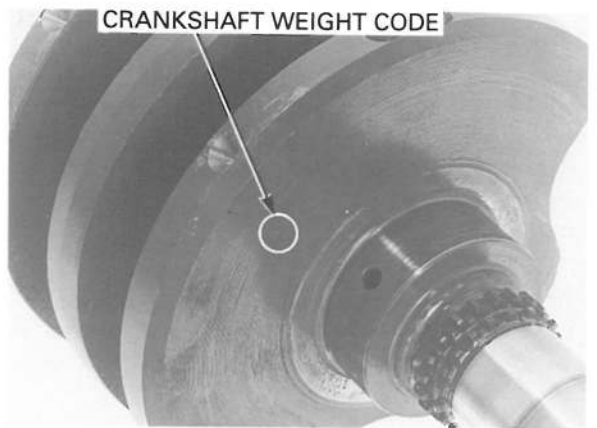
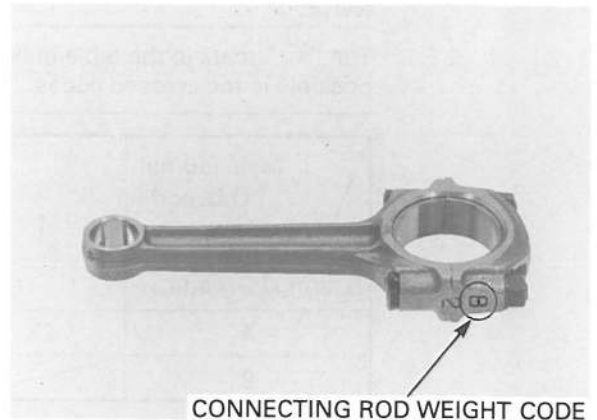

CRANKSHAFT/CRANKCASE SELECTION

Crankcase and crankshaft are select fitted.

Record the main journal O.D. code number (1 or 2).

Record the main journal bearing I.D. code (A or B).

If the crankcase and/or crankshaft are replaced, select them with the following fitting table.

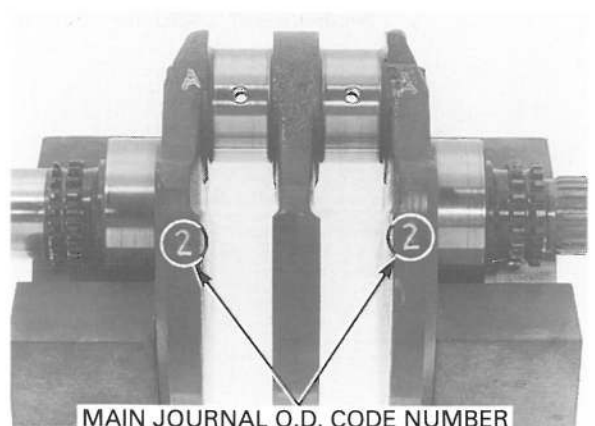

CRANKSHAFT/TRANSMISSION

NOTE:

The "○" mark in the table indicates that mating is possible in the crossed codes.

Main journal O.D. code	1	2
Main journal bearing I.D. code		
A	○	
B		○

MAIN BEARING I.D. CODE

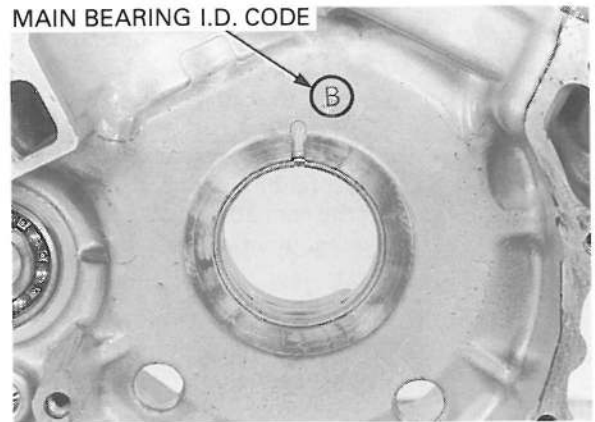

MAIN BEARING INSPECTION

Inspect the bearing inserts for unusual wear, damage or peeling and replace the crankcase if necessary.

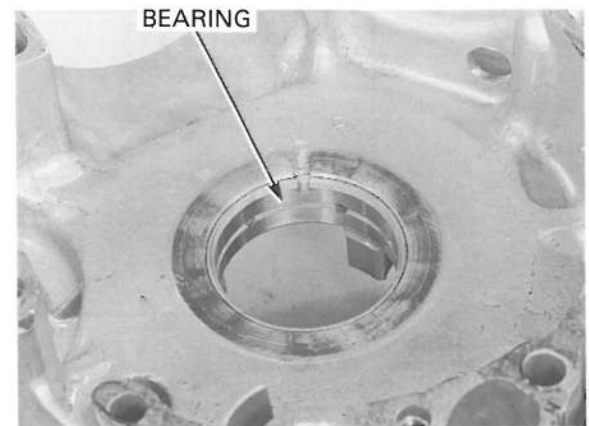

MAIN BEARING OIL CLEARANCE

Clean off any oil from the main bearing inserts and crankshaft journals.

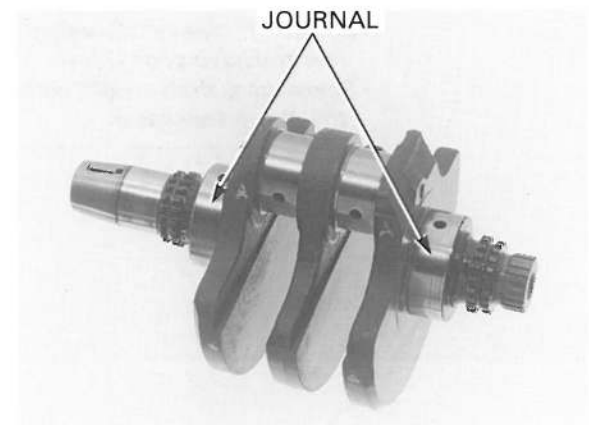

Measure and record the crankshaft main journal O.D..

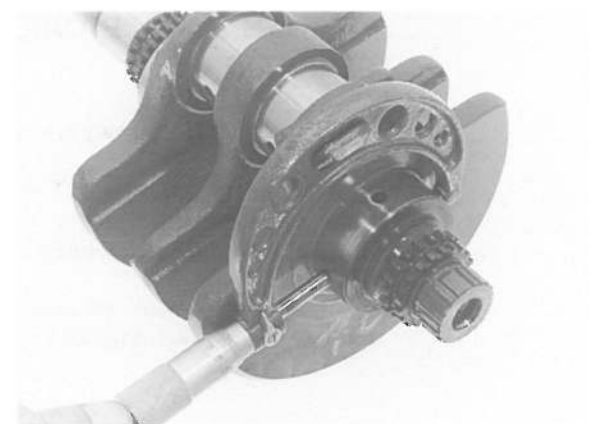

Measure and record the main bearing I.D..

Calculate the oil clearance by subtracting the journal O.D. from bearing I.D..

SERVICE LIMIT: 0.07 mm (0.003 in)

Replace the crankcase if the service limit is exceeded.
Select the replacement crankcase (page 12-9).

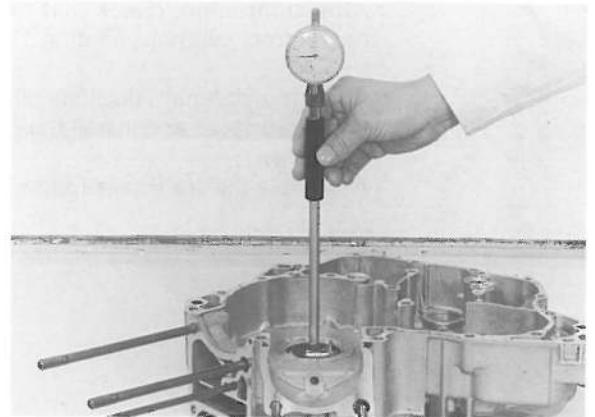

INSTALLATION

Clean off any oil from the main bearing inserts and connecting rod bearing cap.

Apply molybdenum disulfide oil to the bearings.
Install the main bearing to the connecting rod and bearing cap aligning the tab on the bearing with the groove on the connecting rod and bearing cap.

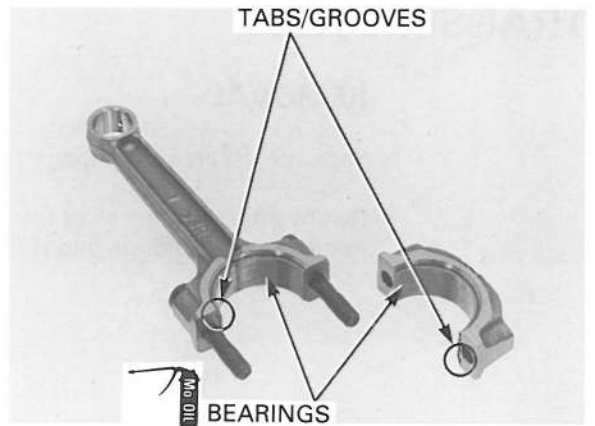

Install the connecting rods and bearing caps on the crankpin.
Be sure the each part is installed in its original position.

NOTE:

Align the I.D. code on the bearing cap and connecting rod.

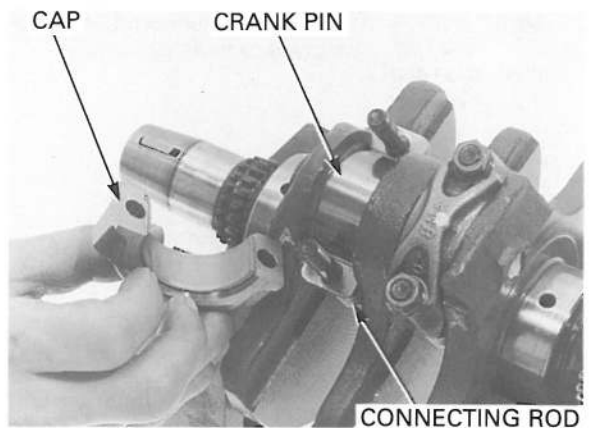

Apply oil to the connecting rod bearing cap bolt/nut threads and flange surface.
Install and tighten the connecting rod bearing cap nuts to the specified torque in several steps.

TORQUE: 33 N·m (3.4 kgf·m, 25 lbf·ft)

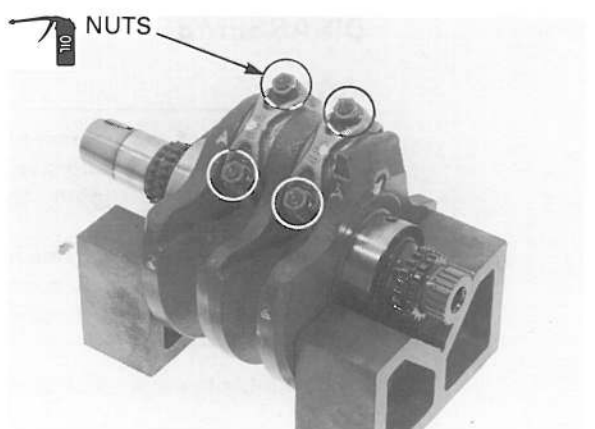

CRANKSHAFT/TRANSMISSION

After tightening, check that the connecting rods move freely without binding.

Apply molybdenum disulfide oil to the main bearing sliding surfaces and install the crankshaft to the left crankcase.

Assemble the crankcase (page 12-22).

CRANKSHAFT/CONNECTING ROD

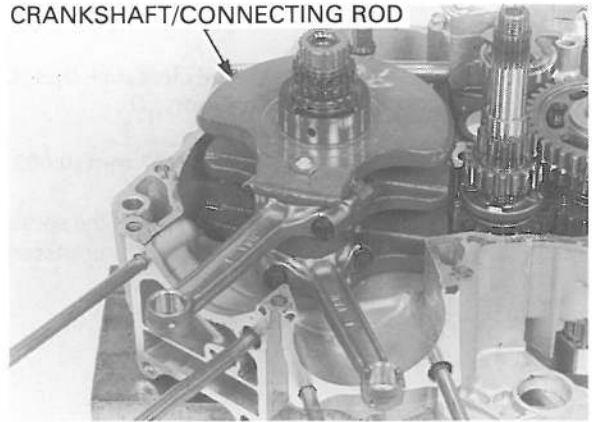

TRANSMISSION

REMOVAL

Separate the crankcase (page 12-4).

Remove the shift fork shaft from the shift fork.
Remove the shift drum and shift fork.

FORK SHAFT

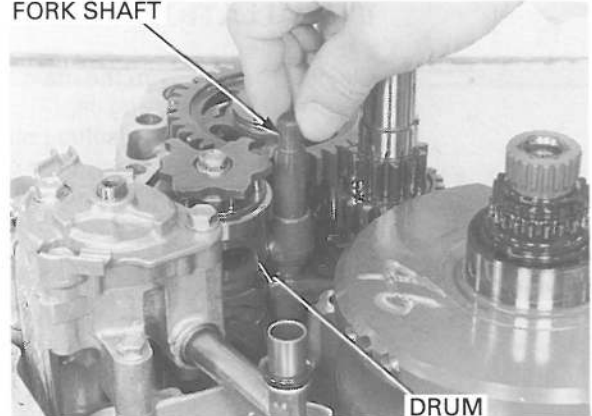

Do not forget to install the transmission end washer.

Remove the mainshaft and countershaft from the left crankcase as assembly.



DISASSEMBLY

NOTE:

- Keep track of the disassembled parts (gears, bushings, washers, and snap rings) by stacking them on a tool or slipping them onto a piece of wire.
- Do not expand the snap ring more than necessary for removal. To remove a snap ring, expand the snap ring and pull it off using the gear behind it.

Disassemble the mainshaft and countershaft.

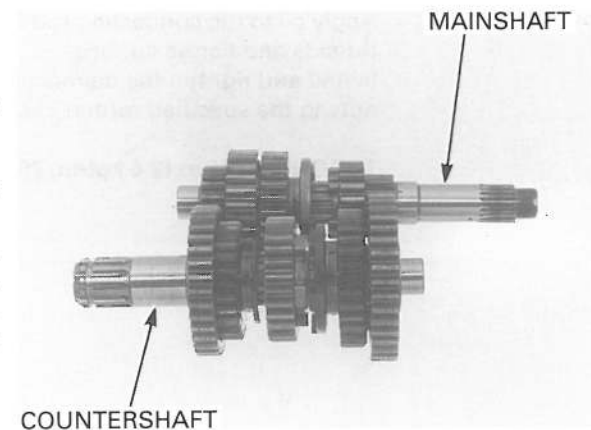

INSPECTION

GEAR

Check the gear dogs, dog holders and teeth for damage or excessive wear.

Measure the I.D. of each gear.

SERVICE LIMITS:

M3, M5: 28.04 mm (1.104 in)

C1, C2, C4: 31.05 mm (1.222 in)

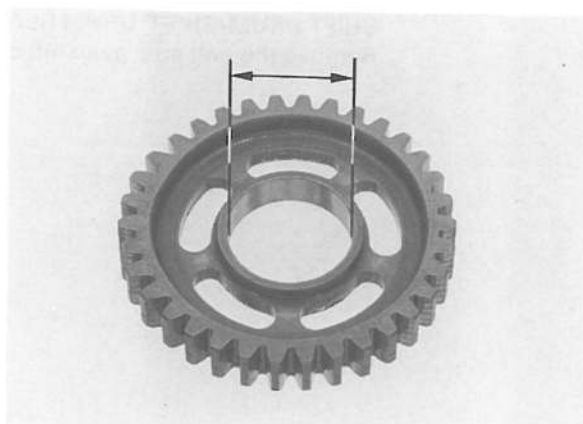

BUSHING

Check the bushings for damage or excessive wear. Measure the O.D. of each bushings.

SERVICE LIMITS:

M2, M5: 27.94 mm (1.100 in)

C1, C2, C4: 30.93 mm (1.218 in)

Measure the I.D. of each bushings.

SERVICE LIMITS:

M3: 25.04 mm (0.986 in)

C2: 28.04 mm (1.104 in)

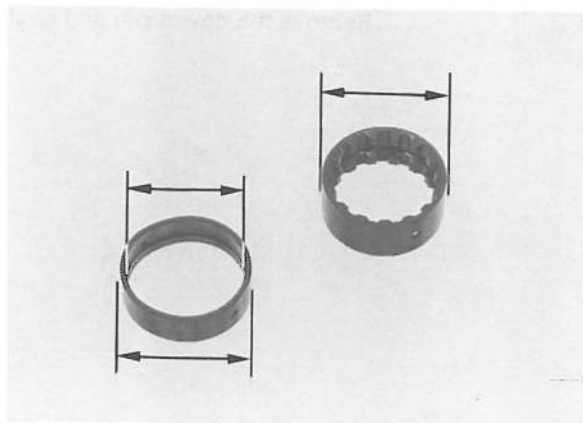

MAINSHAFT/COUNTERSHAFT

Check the spline grooves and sliding surfaces for damage or abnormal wear.

Measure the O.D. of the mainshaft and countershaft at the gear and bushing sliding areas.

SERVICE LIMITS:

Mainshaft:

M3 gear bushing: 24.95 mm (0.982 in)

Case journal A: 19.96 mm (0.786 in)

Case journal B: 21.94 mm (0.864 in)

Countershaft:

C2 gear bushing: 27.95 mm (1.100 in)

Case journal A: 27.95 mm (1.100 in)

Case journal B: 19.96 mm (0.786 in)

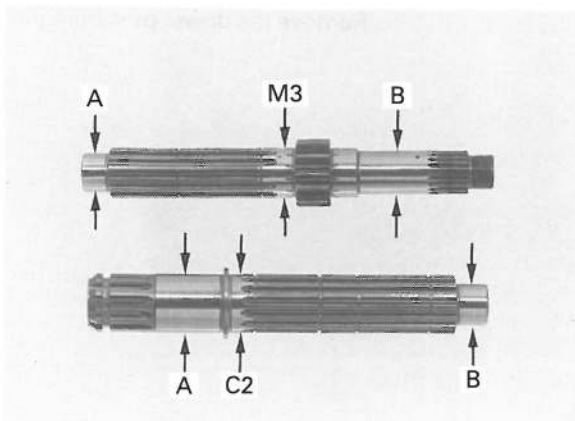

Calculate the clearance by subtracting mainshaft and countershaft O.D. front gear bushing I.D..

SERVICE LIMITS:

M3, C2: 0.08 mm (0.003 in)

Calculate the clearance by subtracting gear bushing O.D. from gear I.D..

SERVICE LIMITS:

M3, M5: 0.10 mm (0.004 in)

C1, C2, C4: 0.11 mm (0.004 in)

CRANKSHAFT/TRANSMISSION

SHIFT DRUM/SHIFT DRUM BEARING

Remove the bolt and gearshift cam plate.

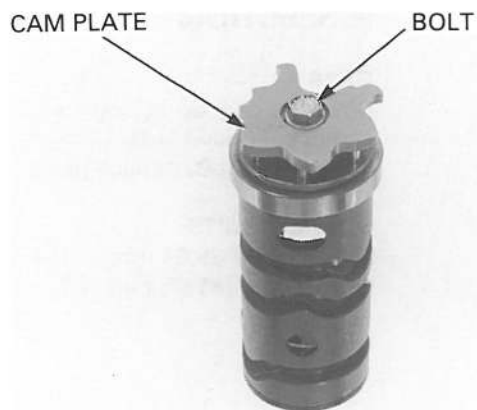

Remove the dowel pin and bearing.

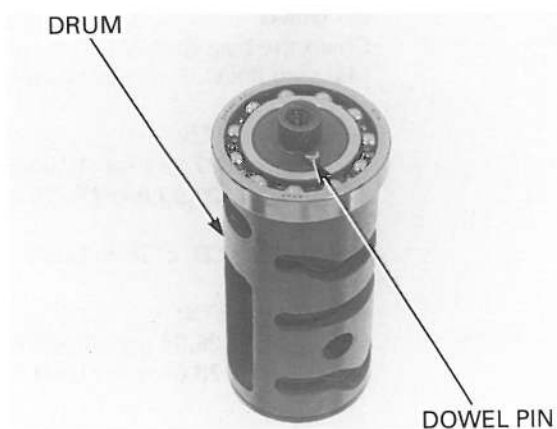

Remove the dowel pins from the gearshift cam plate.

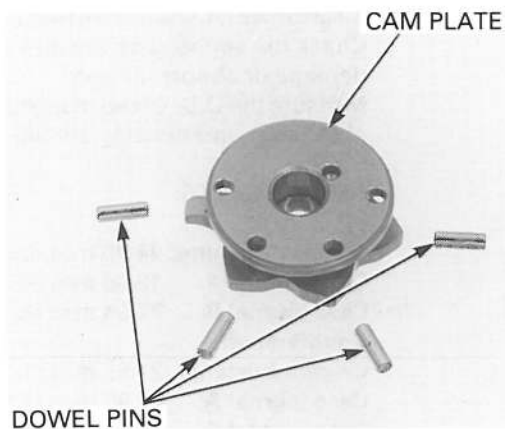

Inspect the shift drum for scoring, scratches or evidence of insufficient lubrication.
Check the shift drum grooves for abnormal wear or damage.
Turn the inner race of bearing with your finger. The bearing should turn smoothly and quietly.



Measure the shift drum O.D. at the left side journal.

SERVICE LIMIT: 11.94 mm (0.470 in)



Install the dowel pins into the cam plate holes.

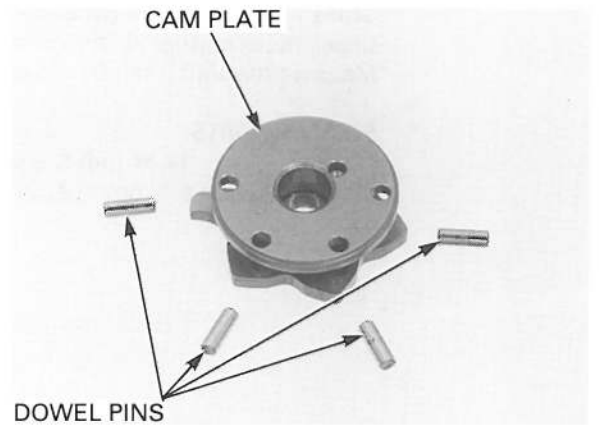

Install the bearing to the shift drum.
Install the dowel pin into the shift drum hole.

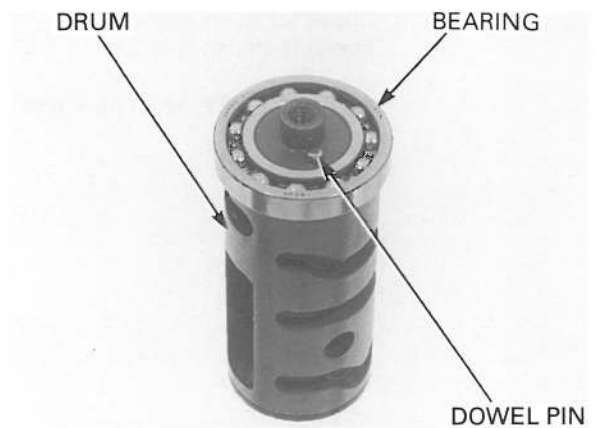

Install the gearshift cam plate by aligning the hole on the cam plate with the dowel pin.

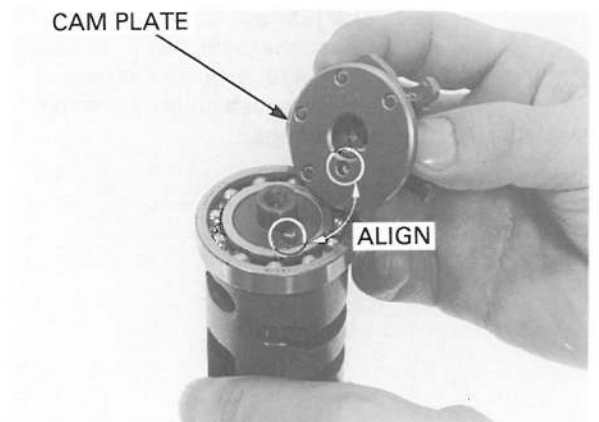

CRANKSHAFT/TRANSMISSION

Clean and apply a locking agent to the gearshift cam plate bolt.
Install and tighten the bolt to the securely.

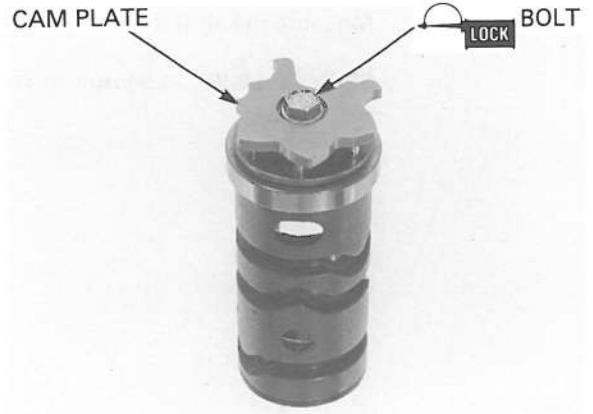

SHIFT FORK, SHIFT FORK SHAFT

Check for abnormal wear or deformation.
Measure the shift fork I.D. and claw thickness.

SERVICE LIMITS:

I.D.: 13.04 mm (0.513 in)

Claw thickness: 5.6 mm (0.22 in)

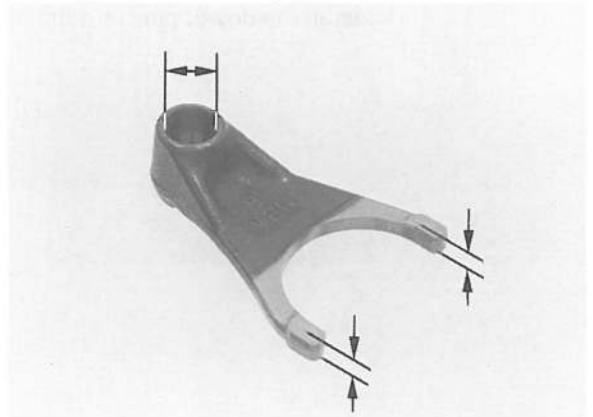

Check for abnormal wear, damage or straightens.
Measure the shift fork shaft O.D..

SERVICE LIMIT: 12.90 mm (0.508 in)

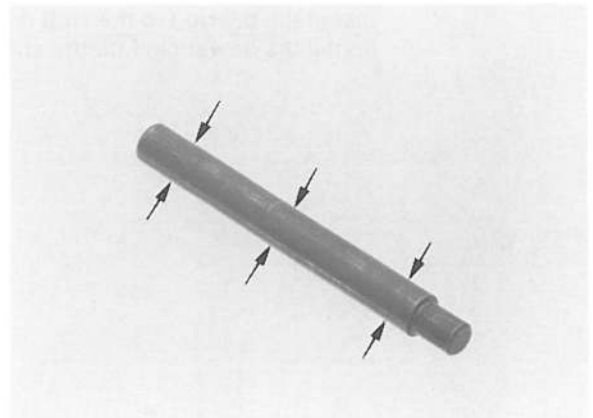

SHIFT DRUM JOURNAL, SHIFT FORK SHAFT JOURNAL

Check the right and left crankcase shift fork shaft journal for wear or damage.

Check the left crankcase shift drum journal for wear or damage.

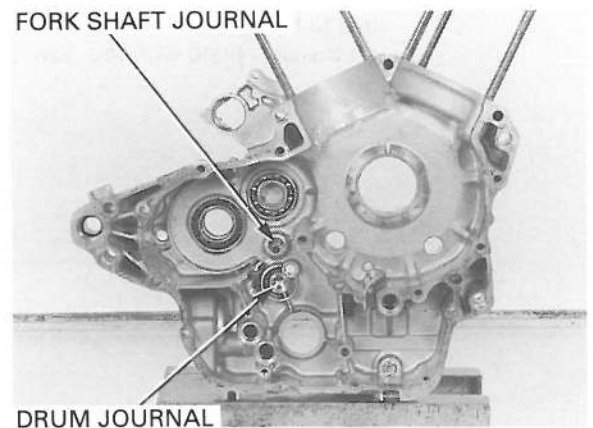

ASSEMBLY

Clean all parts in solvent.
 Apply molybdenum oil solution to the transmission gear shift fork groove, transmission collar inner and outer surface and spline collar outer surface to ensure initial lubrication.
 Assemble all parts into their original positions.

NOTE:

- Check the gears for freedom of movement or rotation on the shaft.
- Install the washers and snap rings with the chamfered edges facing the thrust load side.
- Do not reuse worn snap rings which could easily spin in the grooves.
- Check that the snap rings are seated in the grooves. Align their end gaps with the grooves of the spline.

MAINSHAFT

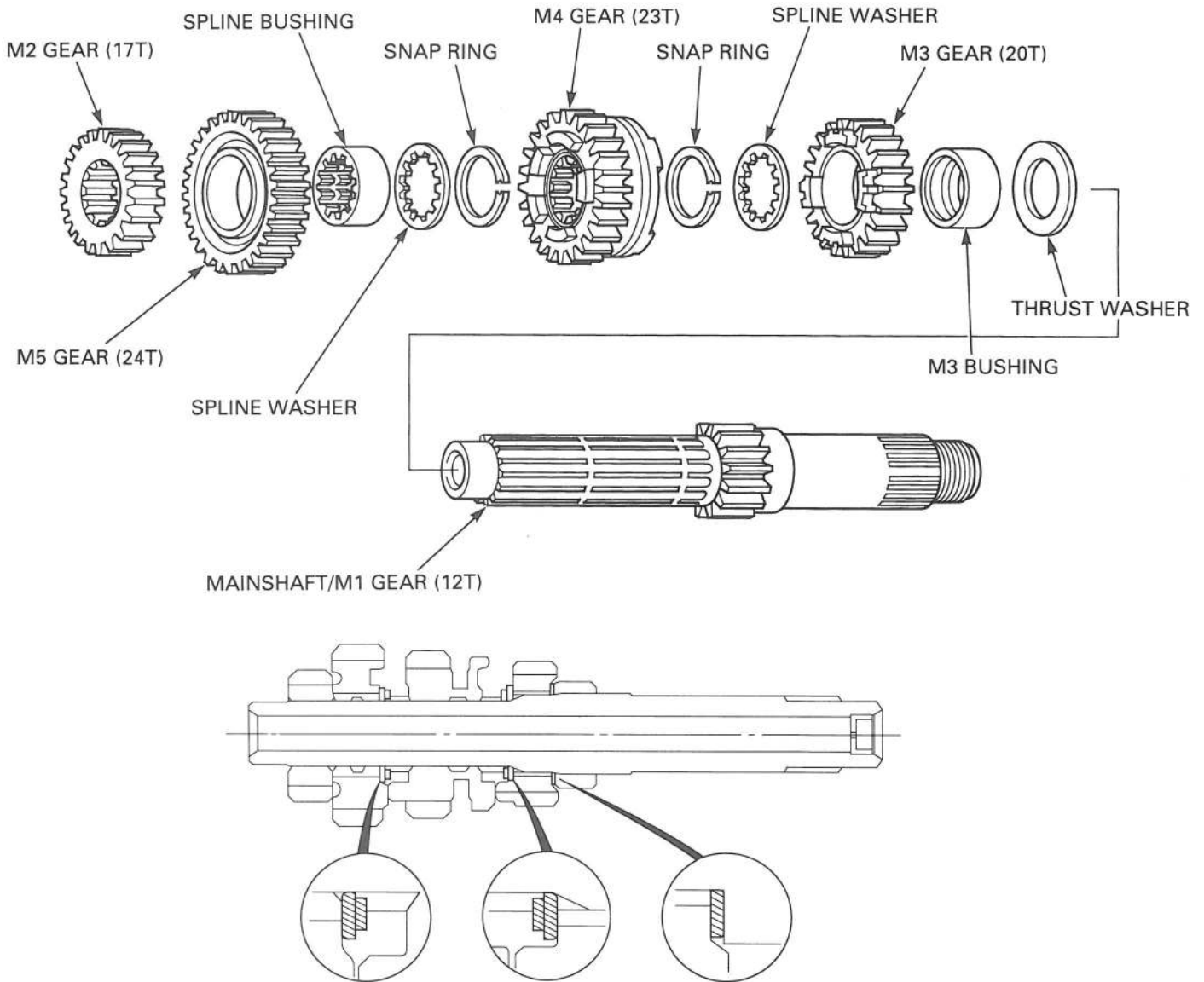

CRANKSHAFT/TRANSMISSION

COUNTERSHAFT

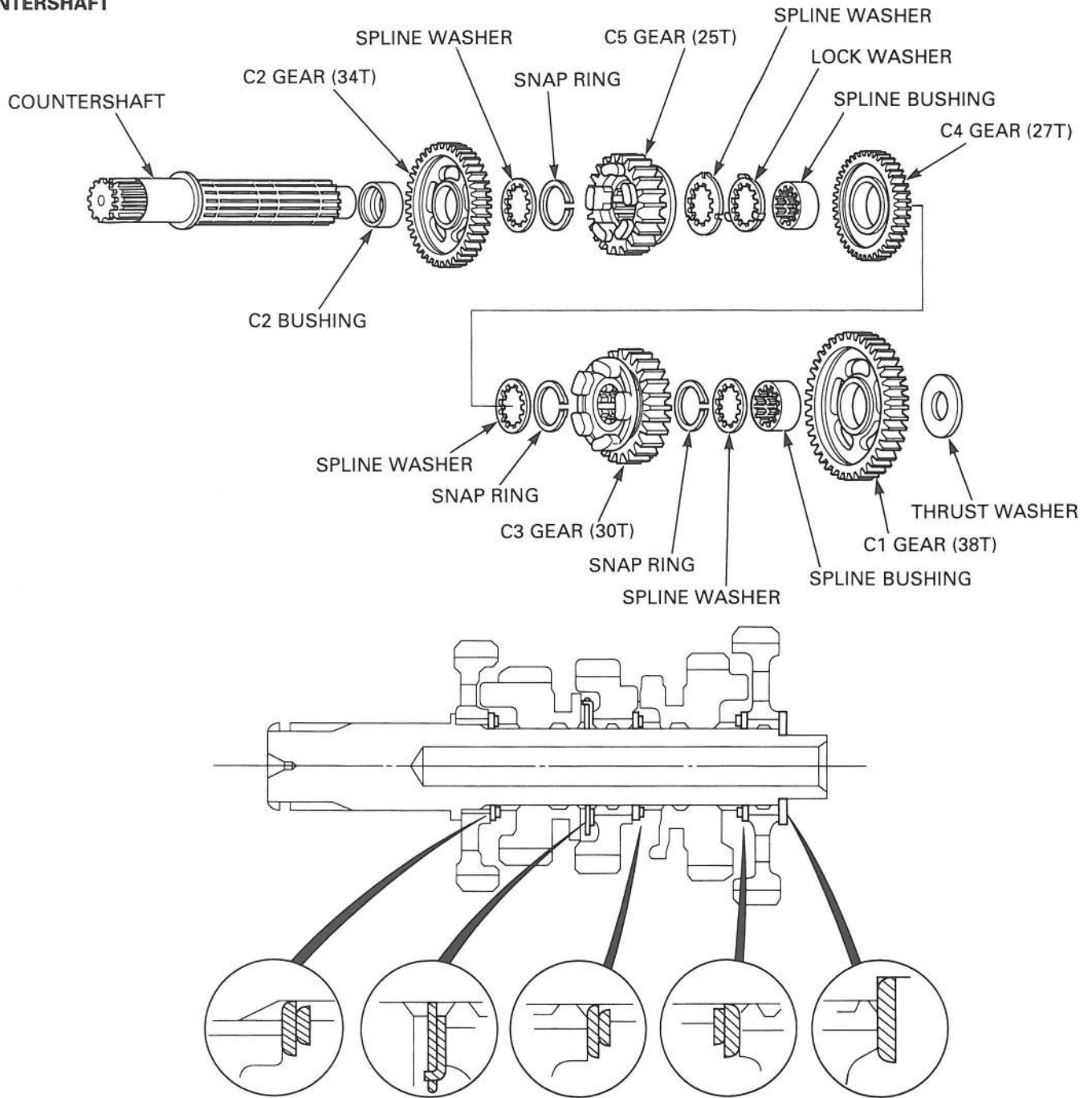

INSTALLATION

Apply engine oil to the following parts:

- Mainshaft
- Countershaft
- Each gear tooth
- Mainshaft bearing
- Countershaft bearing
- Shift drum bearing

Apply molybdenum disulfide oil to the following parts:

- Each gearshift fork grooves
- Each collar inner and outer surfaces
- Each spline collar outer surfaces

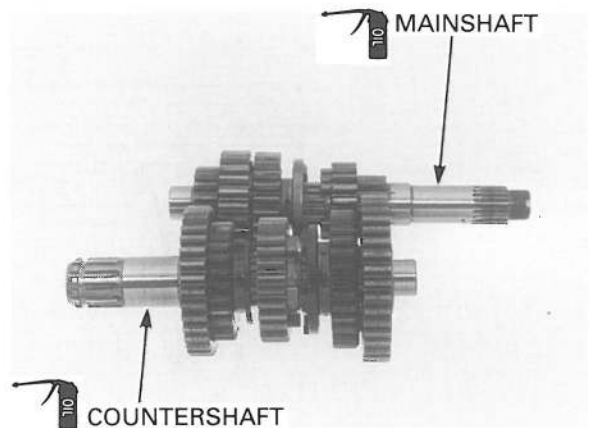

Install the mainshaft and countershaft to the left crankcase as assembly.

NOTE:

- Do not forget to install the transmission end washer.
- When mainshaft and countershaft installation, be careful not to damage the countershaft oil seal.

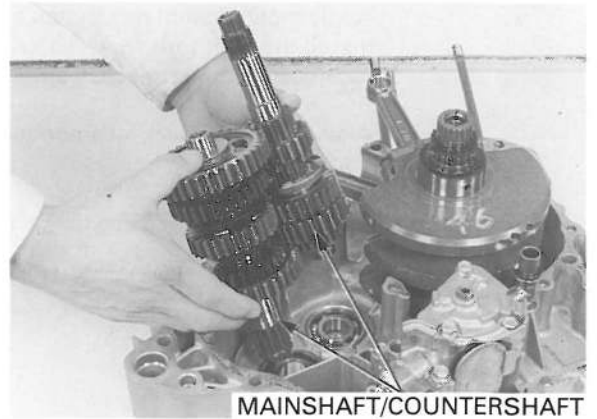

NOTE:

Each shift fork has an identification mark; "R" is for the right shift fork, "L" is for the left shift fork and "C" is for the center shift fork.

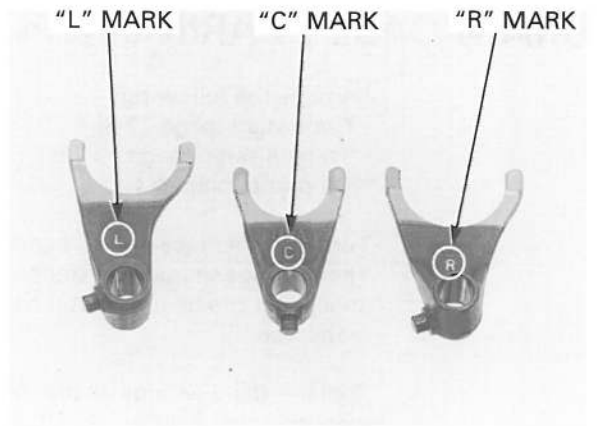

Install the shift forks to the grooves of the shifter gear with their marks facing up (toward right crankcase side).

Install the shift drum by aligning the guide pins on the shift fork with the guide grooves of the shift drum.

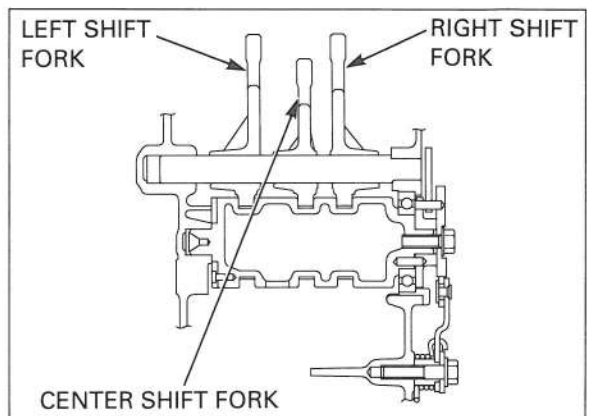
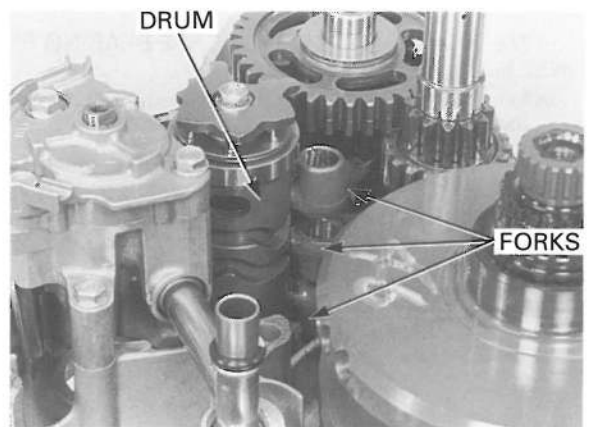

CRANKSHAFT/TRANSMISSION

Apply molybdenum oil solution to the shift fork shaft. Install the shift fork shaft with its stepped end side facing up (right crankcase side).

After installing, check for smooth transmission operation.

Assemble the crankcase (page 12-22).

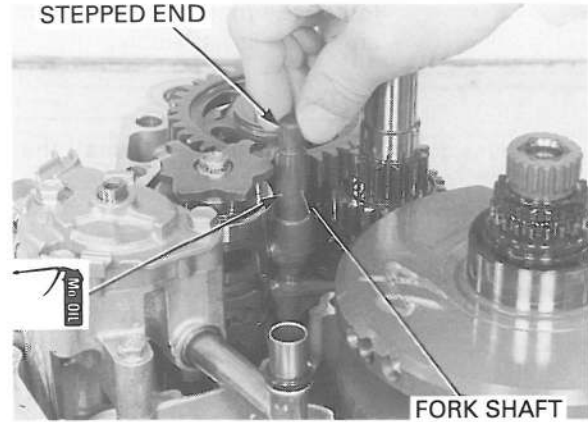

CRANKCASE BEARING REPLACEMENT

Remove the following:

- Crankshaft (page 12-6)
- Transmission (page 12-12)
- Oil pump (page 4-4)

Turn the inner race of each bearing with your finger. The bearings should turn smoothly and quietly. Also check that the bearing outer race fits tightly in the crankcase.

Replace the bearings if the races does not turn smoothly and quietly, or if they fit loosely in the crankcase.

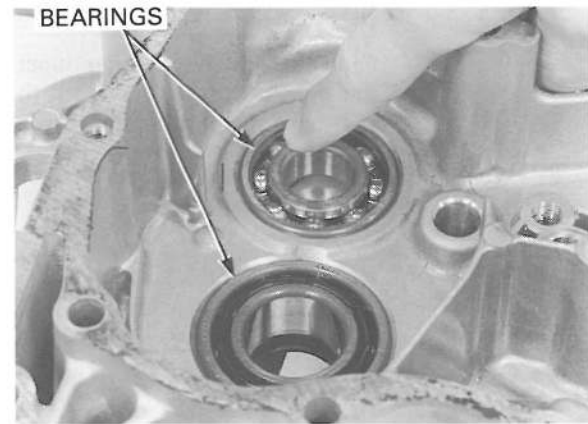

The oil pump must be removed before replacing the crankcase bearing.

LEFT CRANKCASE BEARING REPLACEMENT

Remove the left mainshaft bearing using the special tools.

TOOLS:

- | | |
|----------------------------|--------------------------------|
| Bearing remover set | 07936-3710001 |
| | Not available in U.S.A. |
| - Remover handle | 07936-3710100 |
| - Bearing remover head | 07936-3710600 |
| - Remover sliding weight | 07741-0010201 or |
| | 07936-371020A |
| | (U.S.A. only) or |
| | 07936-3710200 |

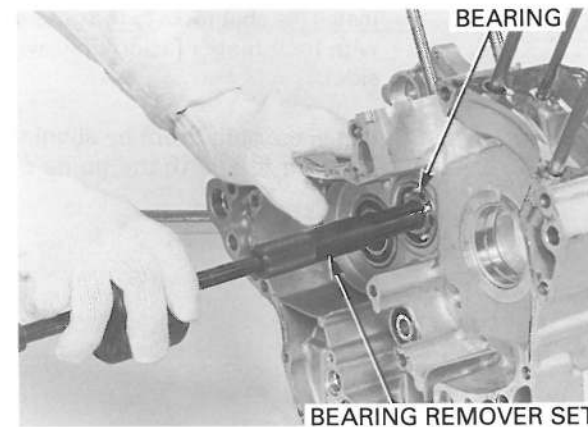

Remove the left countershaft bearing and oil seal.

Drive in the new bearings squarely with the marking side facing up.

Install the new bearings to the left crankcase using the following special tools.

TOOLS:

- | | |
|-------------------------------|----------------------|
| Mainshaft bearing: | |
| Driver | 07749-0010000 |
| Attachment, 42 X 47 mm | 07746-0010300 |

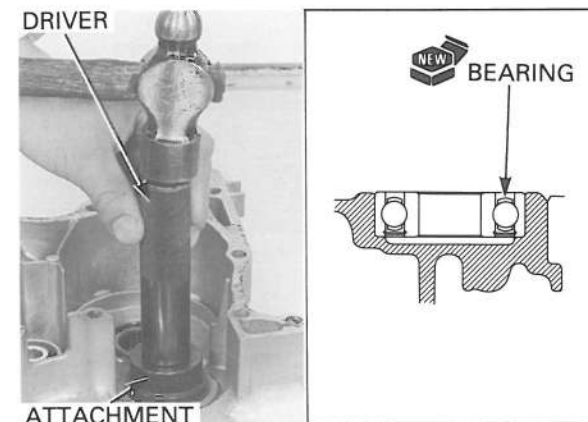

TOOLS:

Countershaft bearing:
Driver 07749-0010000
Attachment, 52 X 55 mm 07746-0010400
Pilot, 25 mm 07746-0041100

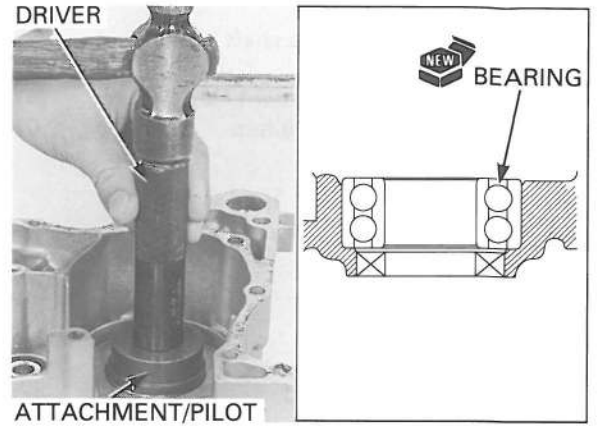

Install the new countershaft oil seal.

Check the gearshift spindle oil seal for damage.
 Replace the gearshift spindle oil seal if necessary.

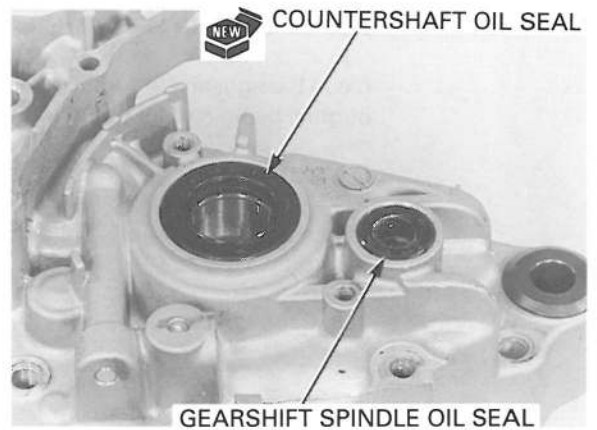

RIGHT CRANKCASE BEARING REPLACEMENT

Drive out the right mainshaft bearing and right countershaft bearing.

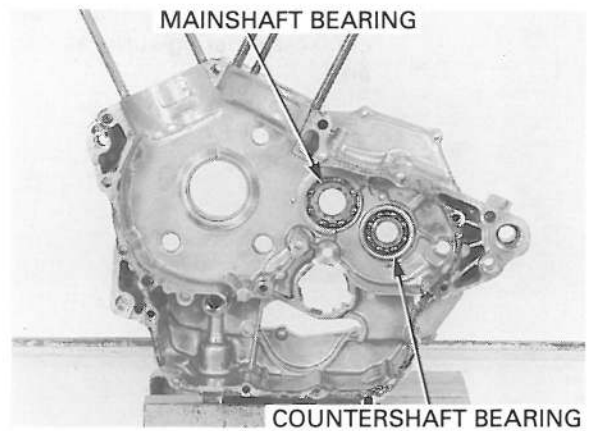

Drive in the new bearings squarely with the marking side facing up.

Install the new bearings to the right crankcase using the following special tools.

TOOLS:

Mainshaft bearing:
Driver 07749-0010000
Attachment, 52 X 55 mm 07746-0010400
Pilot, 25 mm 07746-0040600

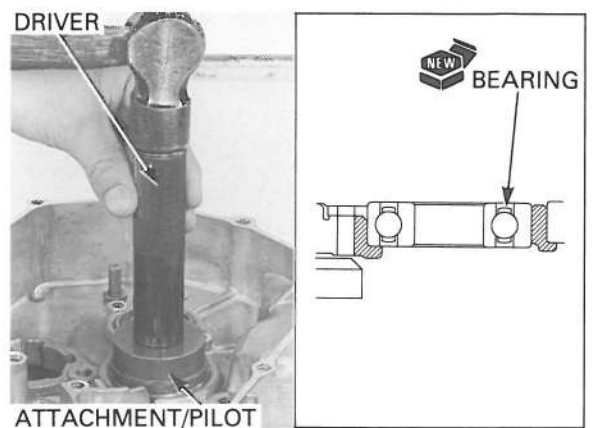

CRANKSHAFT/TRANSMISSION

TOOLS:

Countershaft bearing:

Driver

Attachment, 42X47 mm

Pilot, 20 mm

07749-0010000

07746-0010300

07746-0040500

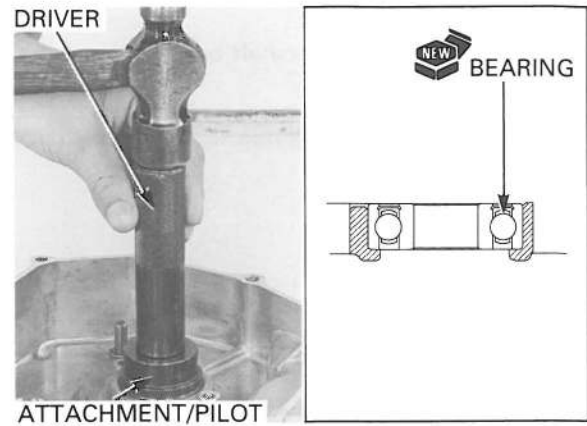

CRANKCASE ASSEMBLY

Clean the right and left crankcase mating surface thoroughly, being careful not to damage them.

Install the following:

- Crankshaft (page 12-11)
- Transmission (page 12-18)
- Oil pump (page 4-9)

Install the dowel pins.

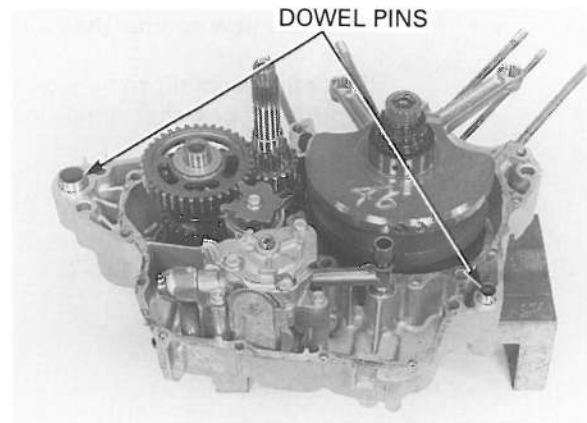

Apply a light but through coating of sealant to all crankcase mating surfaces except the oil passage area.

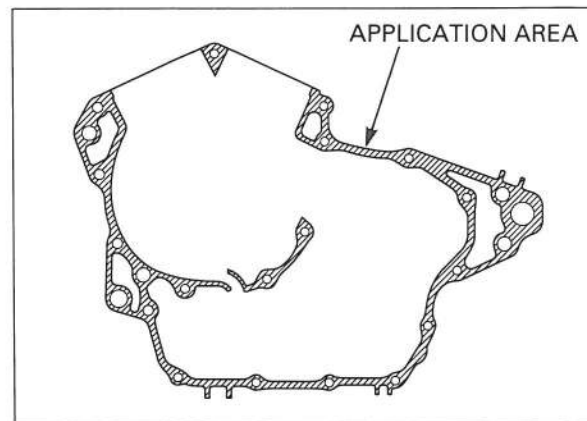

Turn the shift drum until shift cam plate as shown.

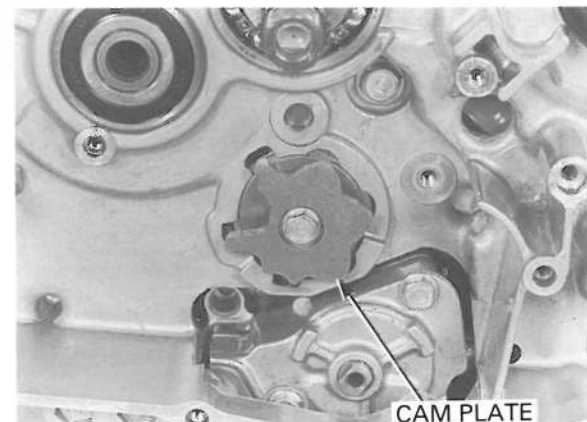

Install the right crankcase to the left crankcase.

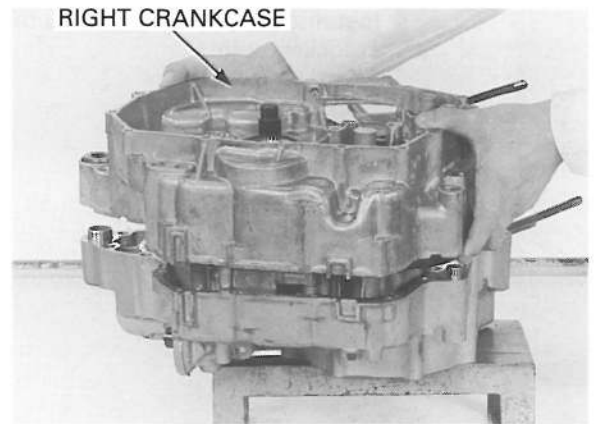

Install and tighten the right crankcase bolts in a criss-cross pattern in several steps.

TORQUE: 8 mm bolt: 23 N•m (2.3 kgf•m, 17 lbf•ft)

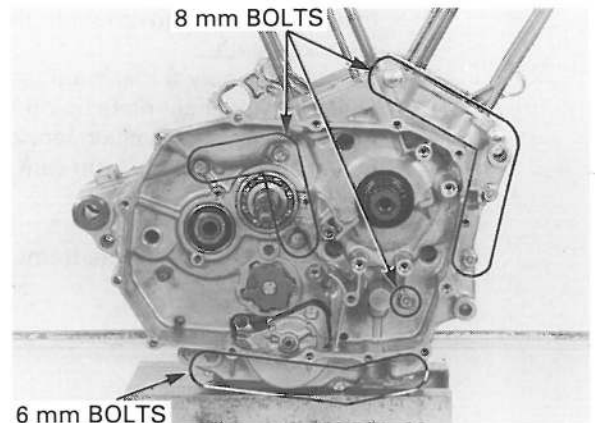

Install and tighten the left crankcase bolts in a criss-cross pattern in several steps.

TORQUE: 8 mm bolt: 23 N•m (2.3 kgf•m, 17 lbf•ft)

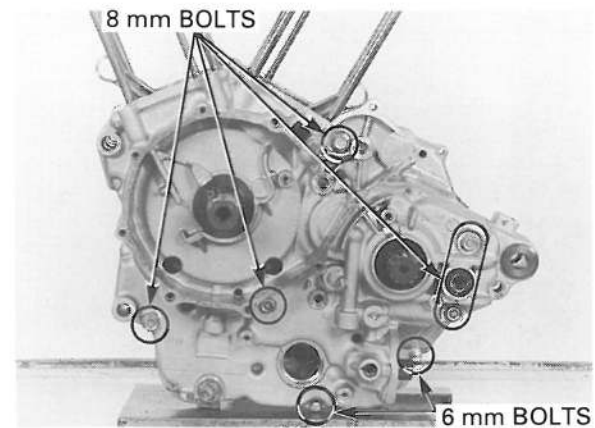

Clean and apply a locking agent to the mainshaft bearing set plate bolt threads.
Install the mainshaft bearing set plate.
Install and tighten the mainshaft bearing set plate bolts securely.

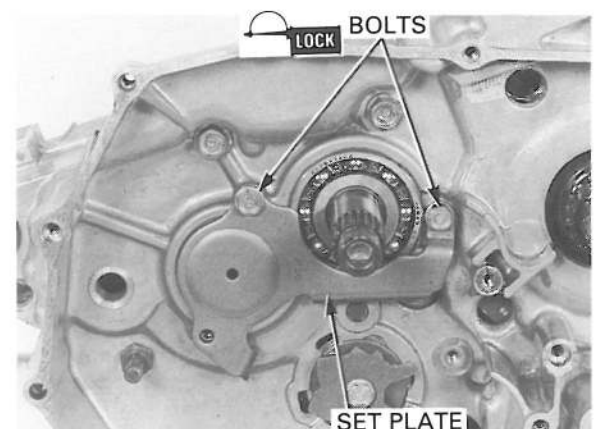

CRANKSHAFT/TRANSMISSION

Install the rear cam chain to the cam chain drive sprocket tooth.

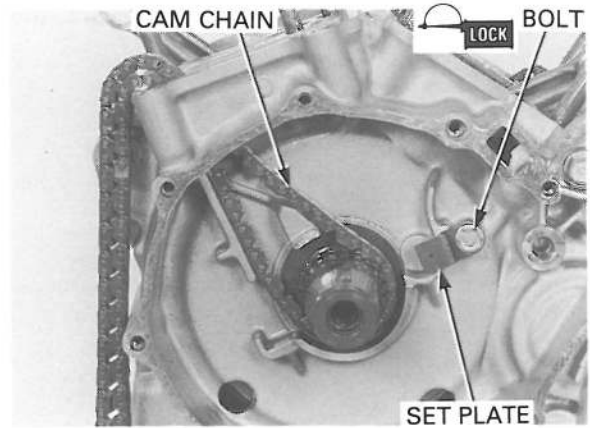

Install the front cam chain to the cam chain drive sprocket tooth.

Clean and apply a locking agent to the front cam chain tensioner set plate bolt threads.

Install the front cam chain tensioner set plate.

Install and tighten the front cam chain tensioner set plate bolt securely.

Install the engine into the frame (Section 7).

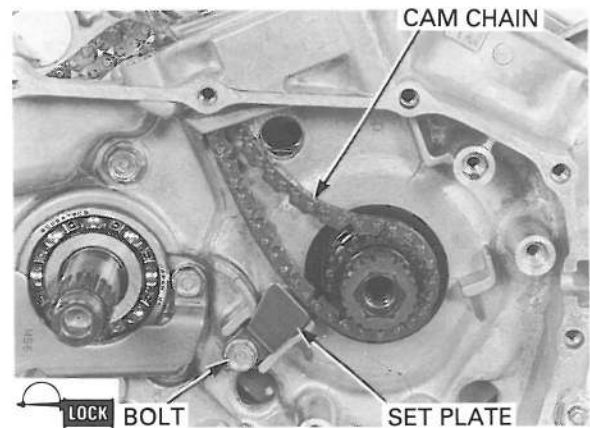

MEMO

FRONT WHEEL/SUSPENSION/STEERING

VT750C :
VT750CD/CD2 ('98 - 2000) :

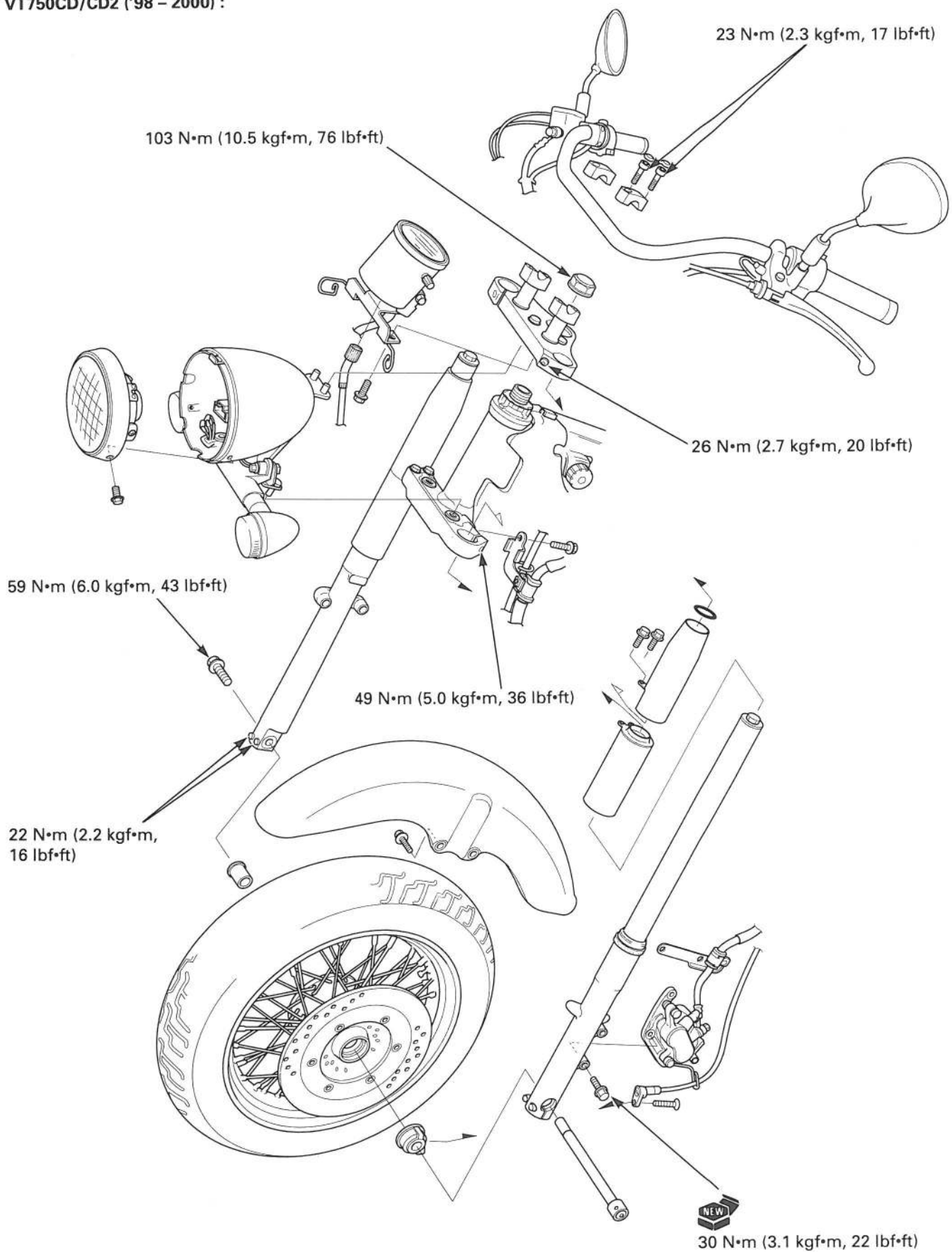

13. FRONT WHEEL/SUSPENSION/STEERING

SERVICE INFORMATION	13-2	FRONT WHEEL	13-13
TROUBLESHOOTING	13-4	FORK	13-22
HANDLEBAR	13-5	STEERING STEM	13-34

VT750CD/CD2 (After 2000) :
VT750C3/CD3 :

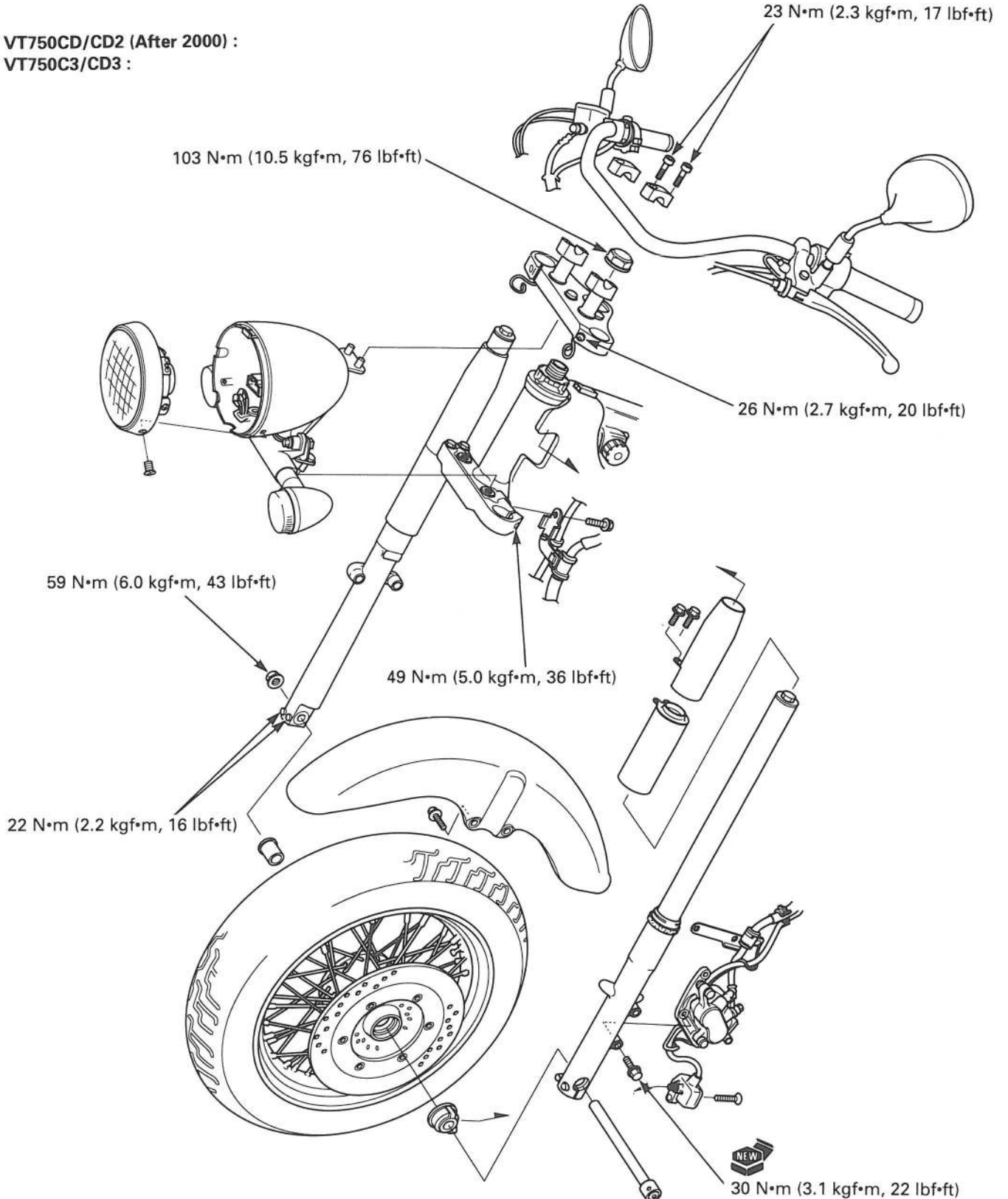

FRONT WHEEL/SUSPENSION/STEERING

GENERAL

WARNING

- A contaminated brake disc or pad reduces stopping power. Discard contaminated pads and clean contaminated disc with a high quality brake degreasing agent.
- Riding on damaged rims or spokes impairs safe operation of the vehicle.
- Wheel balance directly affects the stability, handling and overall safety of the motorcycle. Carefully check balance before reinstalling the wheel.

CAUTION:

- Do not jack up the motorcycle using the oil filter.
 - To avoid damaging the rim when using the tire lever, always use rim protectors.
-
- When servicing the front wheel, support the motorcycle securely with a jack or other adjustable support.
 - Do not operate the brake lever after removing the caliper and front wheel. This will make it difficult to fit the brake disc between the brake pads.
 - Refer to Section 15 for brake system information.

SPECIFICATIONS

Unit: mm (in)

ITEM		STANDARD	SERVICE LIMIT
Minimum tire thread depth		—	1.5 (0.06)
Cold tire pressure	Up to 90 kg (200 lb) load	200 kPa (2.00 kgf/cm ² , 29 psi)	—
	Up to maximum weight capacity	200 kPa (2.00 kgf/cm ² , 29 psi)	—
Axle runout		—	0.20 (0.008)
Wheel rim runout	Radial	—	2.0 (0.08)
	Axial	—	2.0 (0.08)
Wheel hub-to-rim distance		(page 13-17)	—
Wheel balance weight		—	60 g (2.1 oz)
Fork	Spring free length	303.4 (11.94)	297.3 (11.70)
	Spring installed direction	Tightly wound coils should be at the top	—
	Tube runout	—	0.2 (0.008)
	Recommended fork oil	Pro-Honda Suspension Fluid SS-8	—
	Oil level	108 (4.3)	—
	Oil capacity	514 ± 2.5 cm ³ (17.4 ± 0.08 US oz, 18.0 ± 0.09 Imp oz)	—
Steering head bearing preload		0.43 – 1.04 kgf (0.95 – 2.30 lbf)	—

TORQUE VALUES

Steering stem nut	103 N•m (10.5 kgf•m, 76 lbf•ft)	} See page 13-40
Top thread A	21 N•m (2.1 kgf•m, 15 lbf•ft)	
Top thread B	—	
Top bridge pinch bolt	26 N•m (2.7 kgf•m, 20 lbf•ft)	
Bottom bridge pinch bolt	49 N•m (5.0 kgf•m, 36 lbf•ft)	
Handlebar upper holder bolt	23 N•m (2.3 kgf•m, 17 lbf•ft)	
Handlebar lower holder nut	26 N•m (2.7 kgf•m, 20 lbf•ft)	
Handlebar switch screw	3 N•m (0.3 kgf•m, 2.2 lbf•ft)	
Front axle	59 N•m (6.0 kgf•m, 43 lbf•ft)	
Front axle pinch bolt	22 N•m (2.2 kgf•m, 16 lbf•ft)	
Front brake disc bolt	42 N•m (4.3 kgf•m, 31 lbf•ft)	ALOC bolt: Replace with a new one
Fork cap	22 N•m (2.2 kgf•m, 16 lbf•ft)	
Fork socket bolt	29 N•m (3.0 kgf•m, 22 lbf•ft)	Apply a locking agent to the threads
Clutch lever holder bolt	12 N•m (1.2 kgf•m, 9 lbf•ft)	
Brake caliper mounting bolt	30 N•m (3.1 kgf•m, 22 lbf•ft)	ALOC bolt: Replace with a new one
Brake master cylinder holder bolt	12 N•m (1.2 kgf•m, 9 lbf•ft)	
Spoke nipple	4 N•m (0.4 kgf•m, 2.9 lbf•ft)	

TOOLS

Attachment, 42 X 47 mm	07746-0010300	
Attachment, 52 X 55 mm	07746-0010400	
Attachment	07746-0030300	
Pilot, 20 mm	07746-0040500	
Bearing remover shaft	07746-0050100	
Bearing remover head, 20 mm	07746-0050600	
Attachment, 28 X 30 mm	07746-1870100	
Driver	07749-0010000	
Steering stem socket	07916-3710101	or 07916-3710100
Bottom holder pipe	07930-KA50000	
– Holder handle	07930-KA40200	
– Bottom holder attachment	07930-KA50100	
Bearing race remover	07946-3710500	
Slider weight	07947-KA50100	
Driver attachment set	07947-KF00100	
Ball race remover	07953-MJ10000	
– Driver attachment	07953-MJ10100	
– Driver handle	07953-MJ10200	
Spoke wrench	07JMA-MR60100	or equivalent commercially available in U. S. A.

TROUBLESHOOTING

Hard steering

- Steering top thread too tight
- Faulty steering head bearings
- Damaged steering head bearings
- Faulty tire
- Insufficient tire pressure

Steers to one side or does not track straight

- Bent fork
- Faulty steering head bearings
- Damaged steering head bearings
- Bent frame
- Worn wheel bearings
- Bent front axle
- Worn swingarm pivot component

Front wheel wobbling

- Bent rim
- Worn wheel bearings
- Faulty tire
- Unbalanced tire and wheel

Soft suspension

- Weak fork spring
- Low fluid level in fork
- Insufficient fluid in fork
- Low tire pressure

Hard suspension

- High tire pressure
- Bent fork
- High fluid level in fork
- Incorrect fluid weight
- Clogged fluid passage

Front suspension noisy

- Loose fork fasteners
- Insufficient fluid in fork

Wheel turns hard

- Faulty wheel bearings
- Bent front axle
- Brake drag
- Faulty speedometer gear

HANDLEBAR

GRIP REPLACEMENT

Remove the throttle grip from the handlebar (page 13-8).

Remove the grip from the throttle grip.

Apply Pro-Honda Handgrip Cement or equivalent Honda Bond A to the inside surface of the throttle grip to the clean surface of the throttle pipe. Wait 3–5 minutes and install the grip. Rotate the grip for even application of the adhesive.

Install the throttle grip to the handlebar (page 13-10).

Remove the left handlebar grip from the handlebar.

Apply Pro-Honda Handgrip Cement or equivalent to the inside surface of the left handlebar grip to the clean surface of the handlebar. Wait 3–5 minutes and install the grip. Rotate the grip for even application of the adhesive.

NOTE:

Allow the adhesive to dry for an hour before using. Check for smooth throttle operation after the right grip is installed.

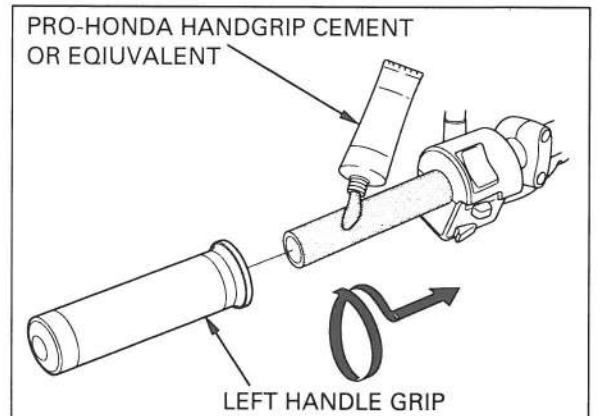
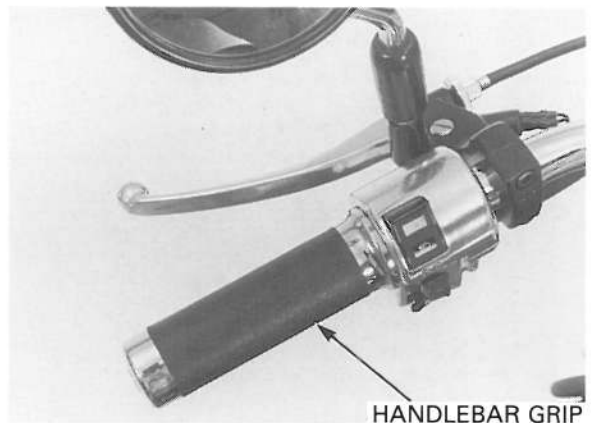
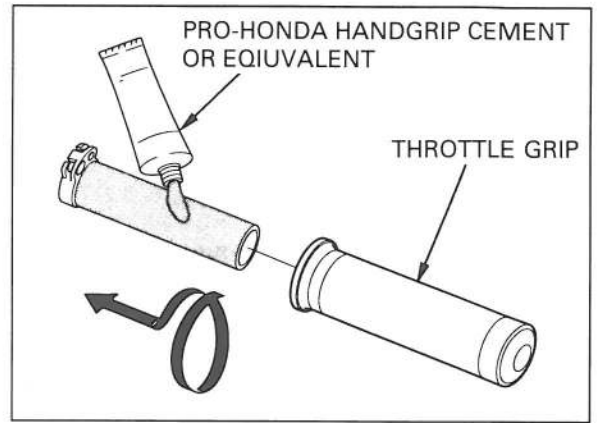
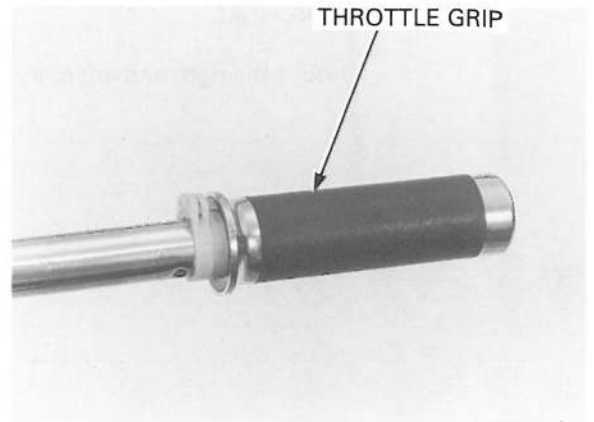

REMOVAL

Remove the right and left rearview mirror.

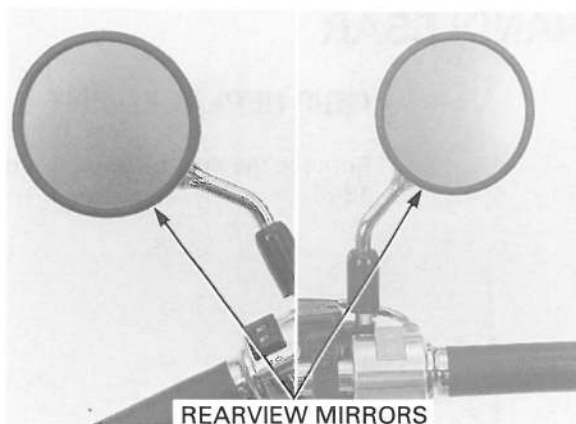

Loosen the clutch cable lower adjusting nuts and disconnect the clutch cable from the clutch lever. Remove the bolt/nut and clutch lever from the clutch lever bracket.

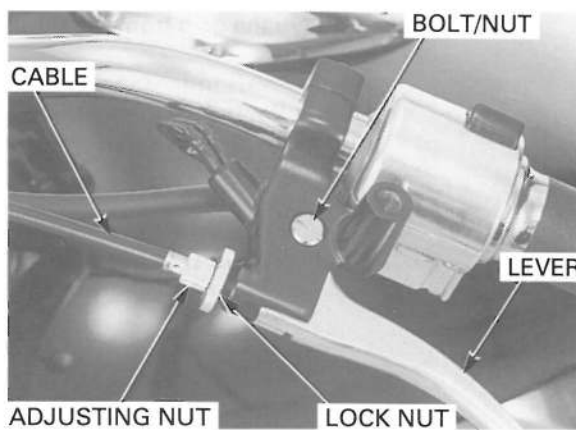

Disconnect the clutch switch connectors from the clutch switch.

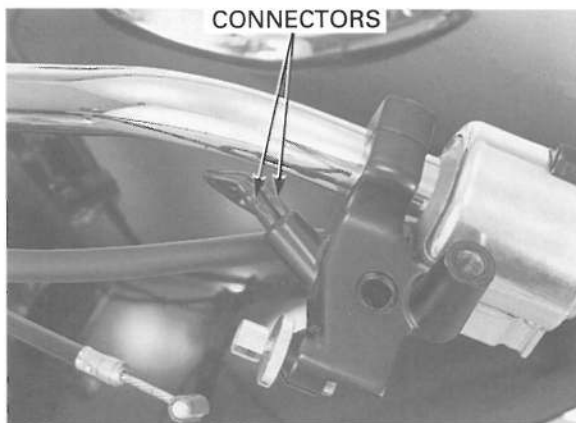

Remove the socket bolts, clutch lever holder and bracket.

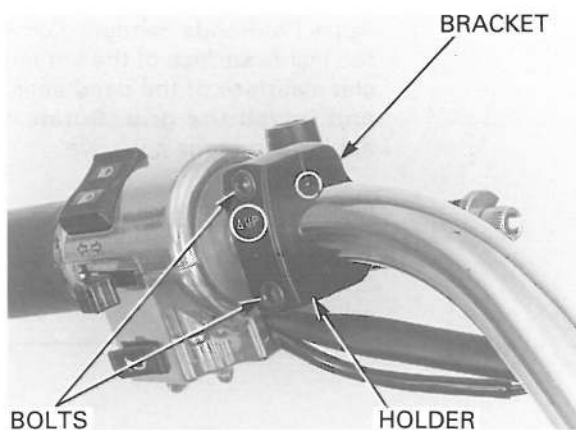

Remove the clutch switch from the clutch holder.



Remove the screws and left handlebar switch.

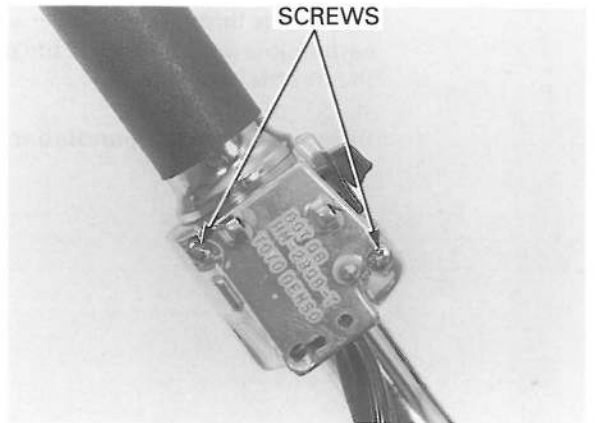

Remove the left handlebar grip and adapter.

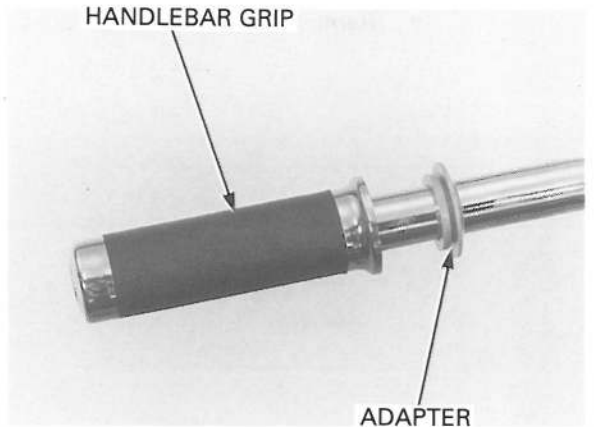

Disconnect the front brake light switch connectors from the switch.

Remove the socket bolts, master cylinder holder and master cylinder.

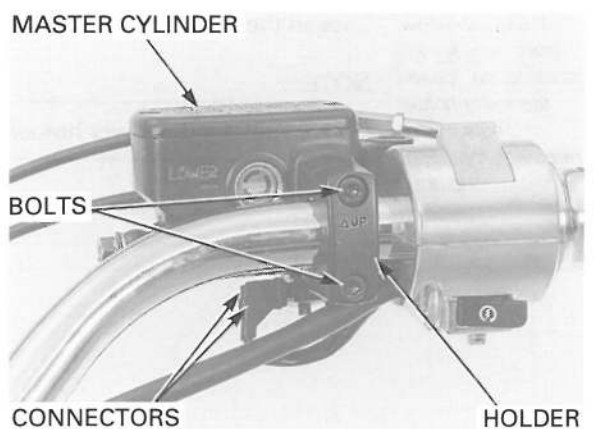

FRONT WHEEL/SUSPENSION/STEERING

Remove the right handlebar switch screws.

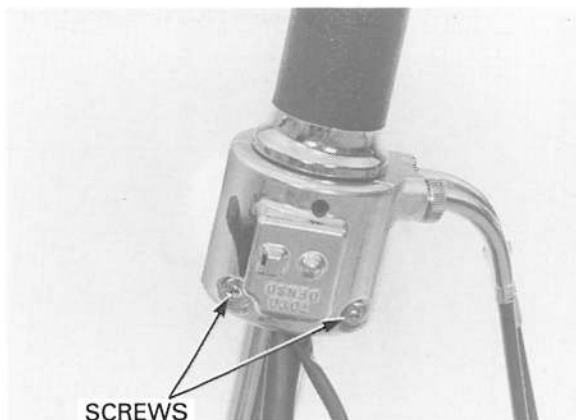

Loosen the throttle cable lower adjusting nuts at the carburetors and disconnect the throttle cables from the throttle cable guide.

Remove the right handlebar switch from the handlebar.

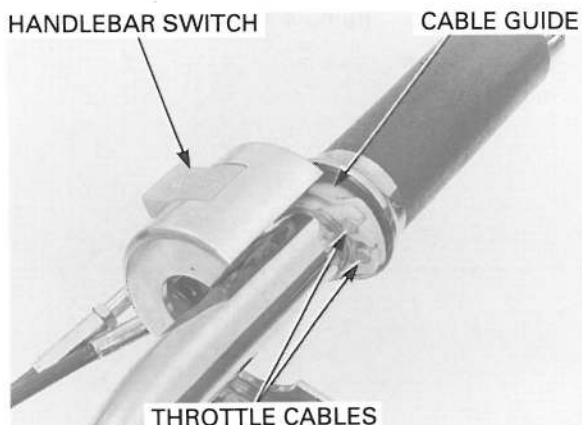

Remove the throttle grip from the handlebar.

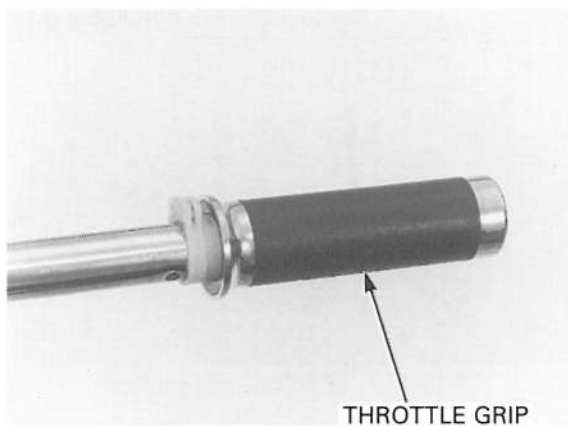

If the handlebar lower holders will be removed, loosen the lower holder nuts before removing the upper holders.

Loosen the handlebar lower holder nuts.

NOTE:

Do not remove the lower holder nuts yet.

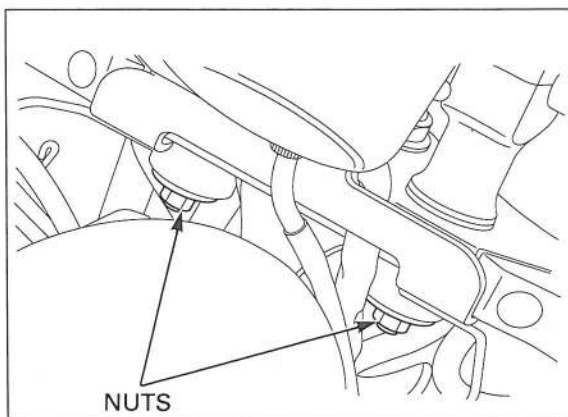

Remove the handlebar upper holder bolt caps.

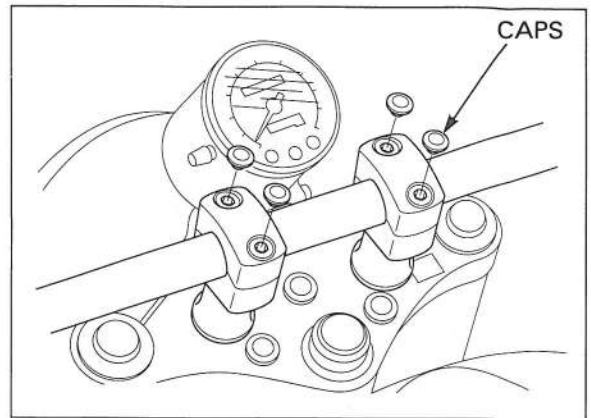

Remove the socket bolts, upper holders and handlebar.

INSTALLATION

Install the handlebar and upper holders with their punch marks facing forward.

Temporarily tighten the upper holder socket bolts.

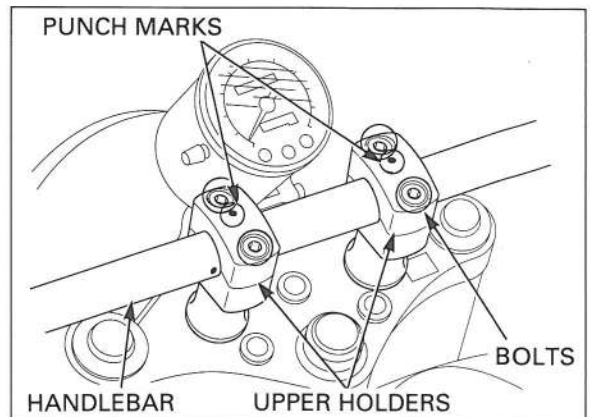

If the handlebar lower holders removed, Tighten the lower holder nuts to the specified torque.

TORQUE: 23 N·m (2.3 kgf·m, 16 lbf·ft)

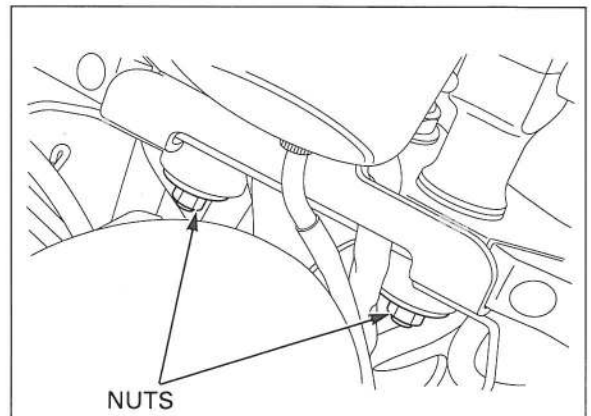

Loosen the upper holder socket bolts and align the punch marks on the handlebar with the splits of the handlebar holders.

Tighten the forward bolts first, then tighten the rear bolts.

TORQUE: 23 N·m (2.3 kgf·m, 17 lbf·ft)

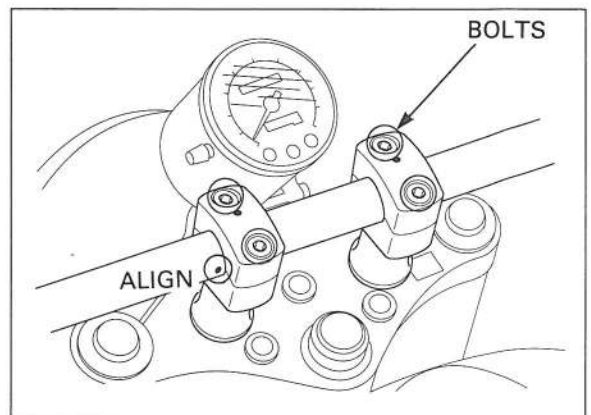

FRONT WHEEL/SUSPENSION/STEERING

Install the upper holder bolt caps.

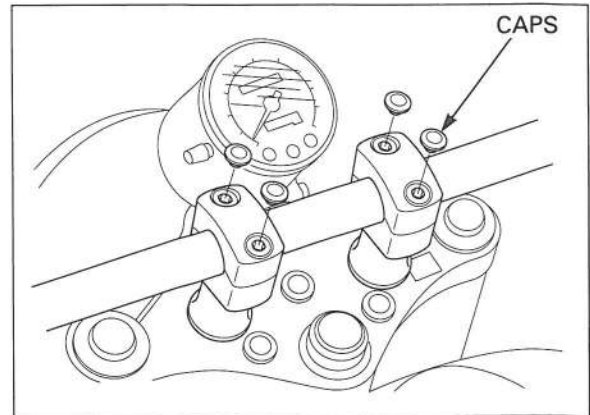

Apply grease to the throttle grip inner surface and throttle cable contact point.
Install the throttle grip to the handlebar.

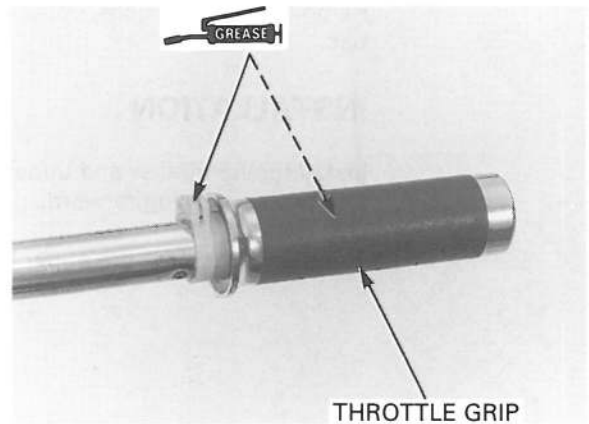

Apply grease to the throttle cable end.
Connect the throttle cables to the throttle cable guide.

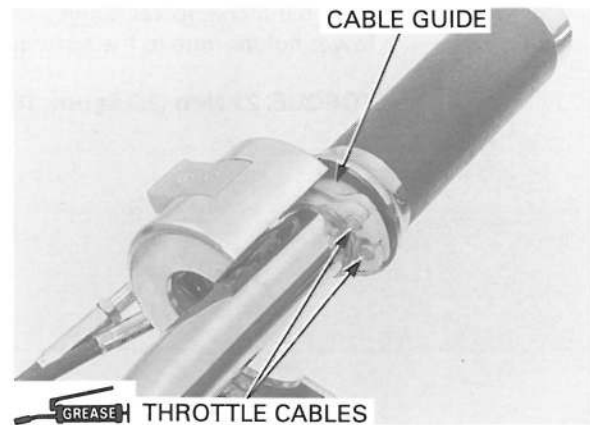

Install the right handlebar switch housing onto the handlebar, aligning the locating pin with the hole in the handlebar.

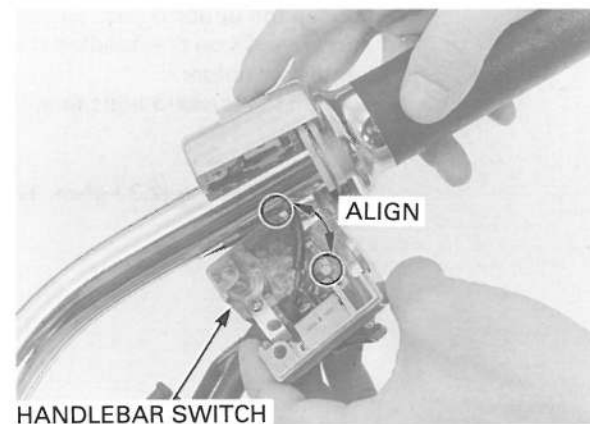

Install the attaching screws and tighten the forward screw first, then tighten the rear screw to the specified torque.

TORQUE: 3 N·m (0.3 kgf·m, 2.2 lbf·ft)



Install the master cylinder and holder with the "UP" mark facing up.

Align the end of the master cylinder with the punch mark on the handlebar and tighten the upper bolt first, then tighten the lower bolt to the specified torque.

TORQUE: 12 N·m (1.2 kgf·m, 9 lbf·ft)

Connect the front brake light switch connector to the switch.

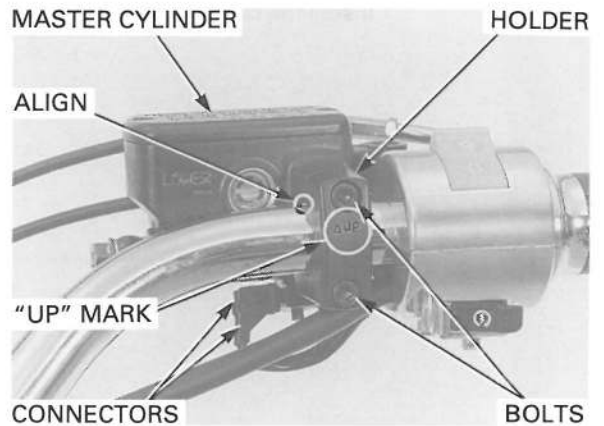

Install the adapter and left handlebar grip onto the handlebar (refer to page 13-5).

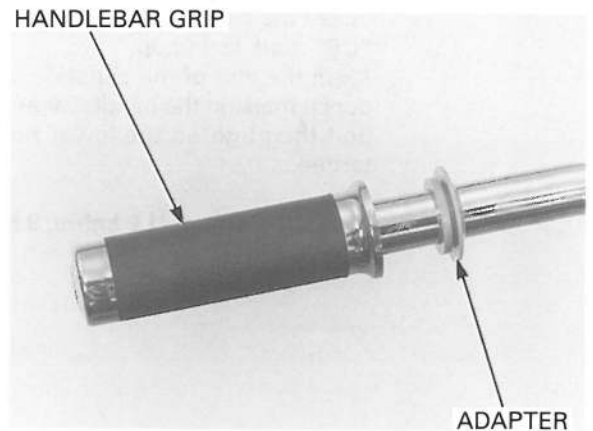

Install the left handlebar switch housing onto the handlebar by aligning the locating pin with the hole in the handlebar.

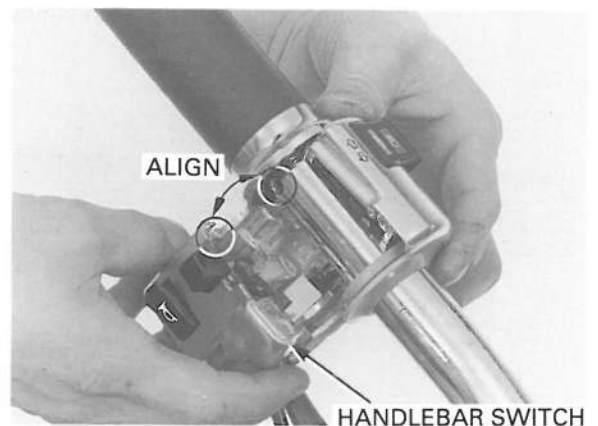

FRONT WHEEL/SUSPENSION/STEERING

Install the attaching screws and tighten the forward screw then tighten the rear screw to the specified torque.

TORQUE: 3 N·m (0.3 kgf·m, 2.2 lbf·ft)

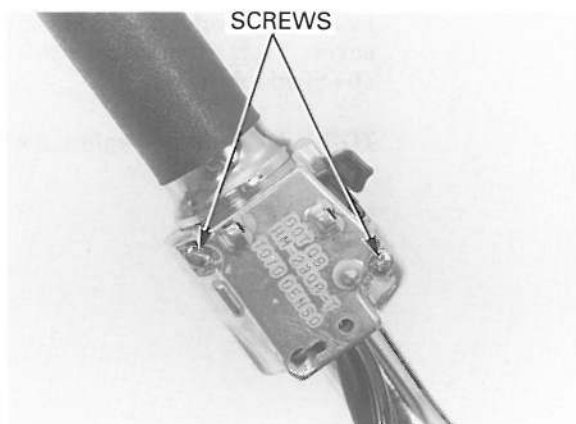

Install the clutch switch into the clutch lever bracket.



Install the clutch lever bracket and holder with the "UP" mark facing up.
Align the end of the clutch lever bracket with the punch mark on the handlebar and tighten the upper bolt then tighten the lower bolt to the specified torque.

TORQUE: 12 N·m (1.2 kgf·m, 9 lbf·ft)

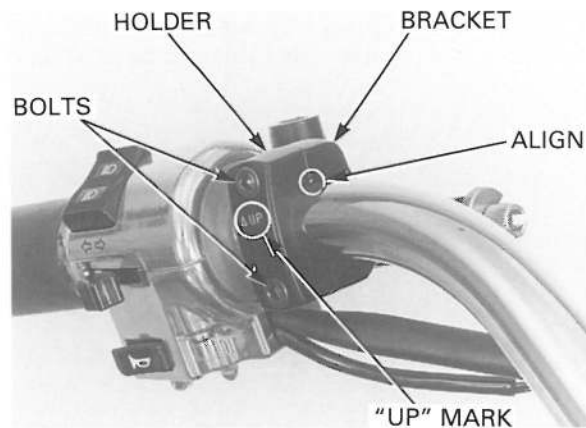

Connect the clutch switch connectors to the clutch switch.

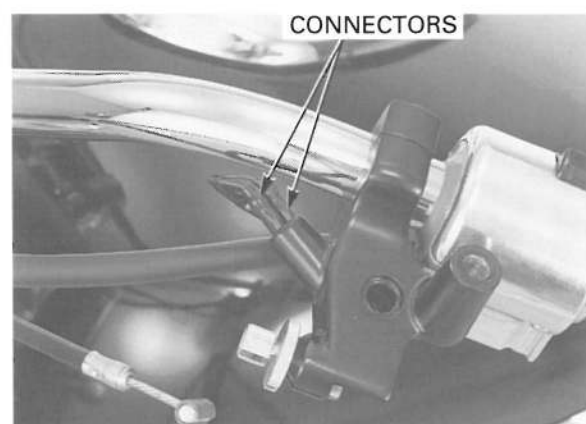

Apply grease to the clutch lever pivot bolt sliding surface.

Install the clutch lever to the clutch lever bracket. Install and tighten the bolt and nut securely.

Connect the clutch cable to the lever.

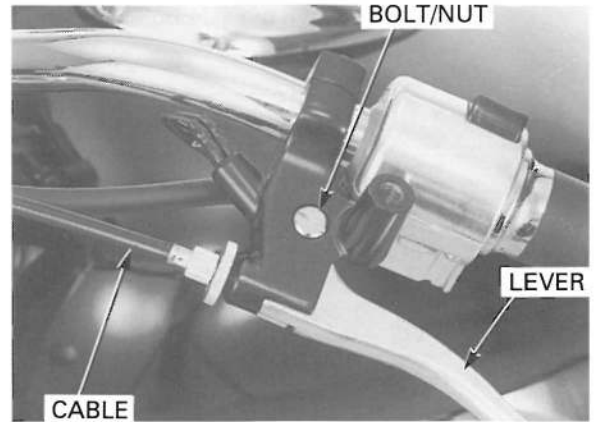

Install the right and left rearview mirrors.

NOTE:

Route the cables, wires and harness properly (page 1-22).

Adjust the following:

- Throttle operation free play (page 3-4).
- Clutch lever free play (page 3-26).

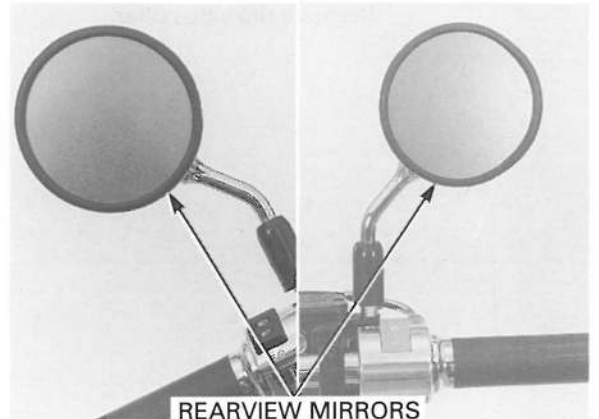

FRONT WHEEL

⚠ WARNING

A contaminated brake disc or pad reduces stopping power. Discard contaminated pads and clean contaminated disc with a high quality brake degreasing agent.

REMOVAL

Raise and support the motorcycle using a hoist or jack.

CAUTION:

Do not jack up the motorcycle using the oil filter.

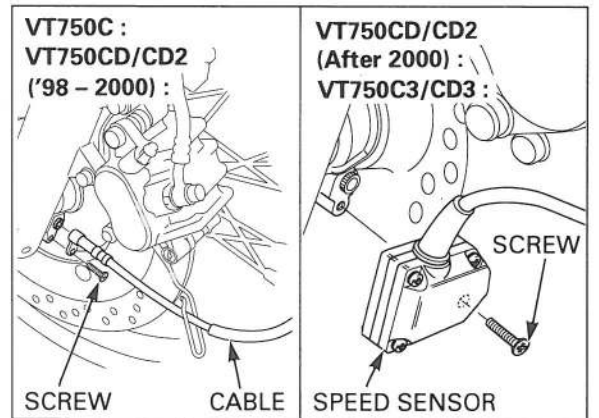

VT750C and VT750CD/CD2 ('98 - 2000): Remove the screw and speedometer cable from the speedometer gear.

VT750C3/CD3 and VT750CD/CD2 (after 2000): Remove the screw and speed sensor from the speedometer gear.

Loosen the axle pinch bolts.

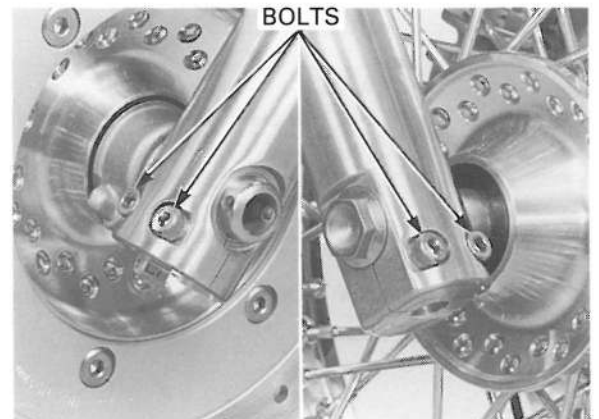

FRONT WHEEL/SUSPENSION/STEERING

Remove the axle bolt, axle and front wheel.

NOTE:

Do not operate the front brake lever after removing the front wheel. This will make it difficult to fit the brake disc between the brake pads.

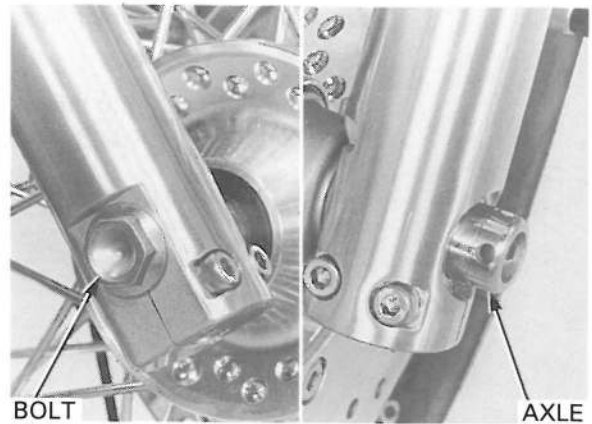

Remove the side collar.

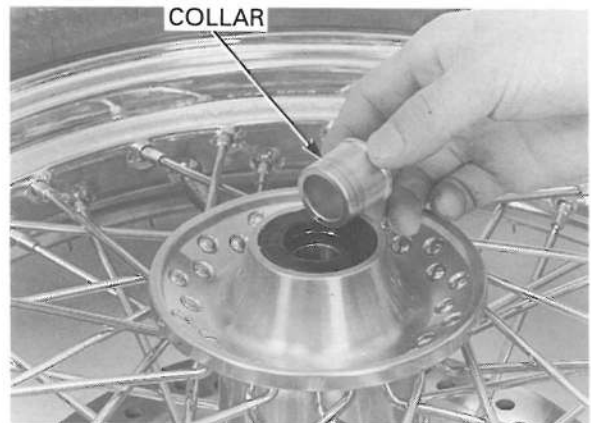

Remove the speedometer gear box.

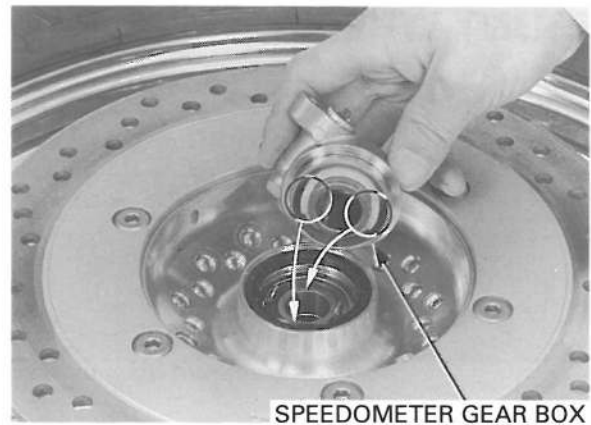

INSPECTION

AXLE

Set the front axle in V-blocks and measure the runout.

Turn the front axle and measure the runout using a dial indicator.

Actual runout is 1/2 the total indicator reading.

SERVICE LIMIT: 0.2 mm (0.008 in)

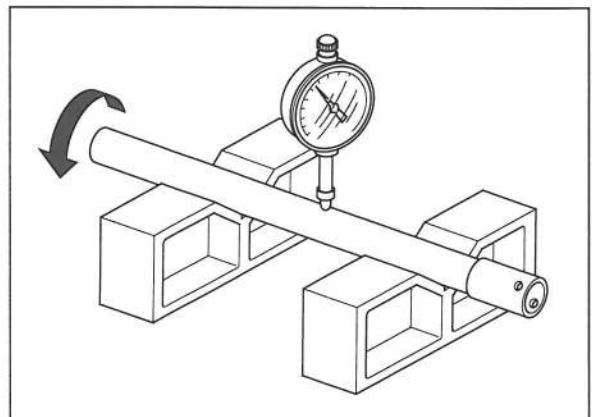

WHEEL BEARING

Turn the inner race of each bearings with your finger. The bearings should turn smoothly and quietly. Also check that the bearing outer race fits tightly in the hub.

Replace the wheel bearings in pairs.

Remove and discard the bearings if the races do not turn smoothly and quietly, if they fit loosely in the hub.

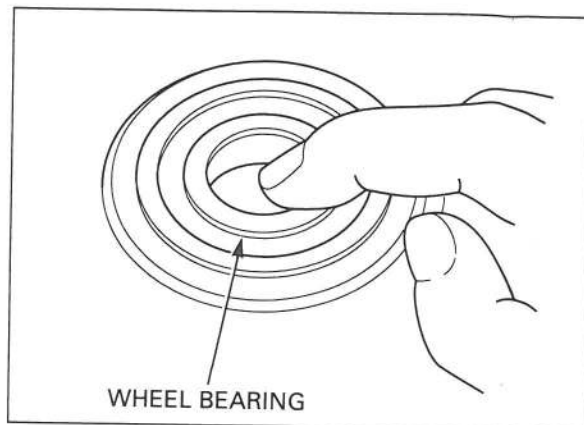

WHEEL RIM

Check the rim runout by placing the wheel in a truing stand.

Spin the wheel slowly and read the runout using a dial indicator.

Actual runout is 1/2 the total indicator reading.

SERVICE LIMITS:

Radial: 2,0 mm (0.08 in)

Axial: 2.0 mm (0.08 in)

Check the spokes for loose or damage.

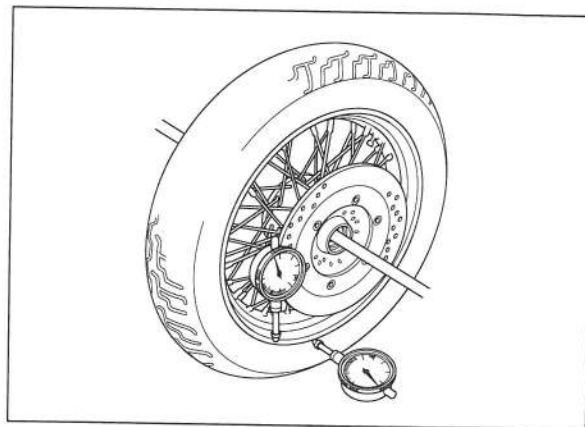

DISASSEMBLY

Remove the right dust seal from the right side of the front wheel.



Remove the left dust seal from the left side of the front wheel.

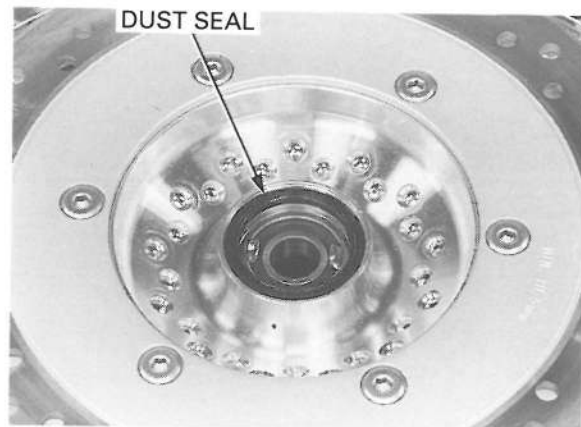

FRONT WHEEL/SUSPENSION/STEERING

Remove the speedometer gear retainer.

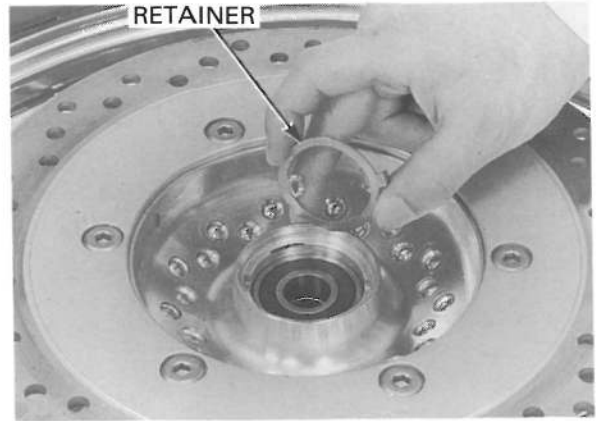

Remove the brake disc mounting bolts and brake disc.

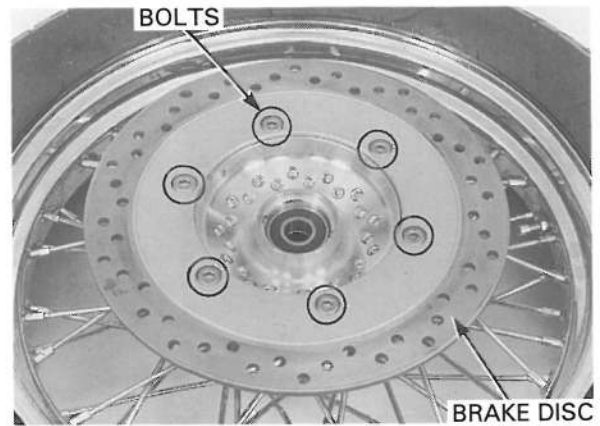

Replace the wheel bearings in pairs. Do not re-use old bearings.

Install the bearing remover head into the bearing. From opposite side install the bearing remover shaft and drive the bearing out of the wheel hub. Remove the distance collar and drive out the other bearing.

TOOLS:

Bearing remover shaft 07746 - 0050100
Bearing remover head, 20 mm 07746 - 0050600



ASSEMBLY

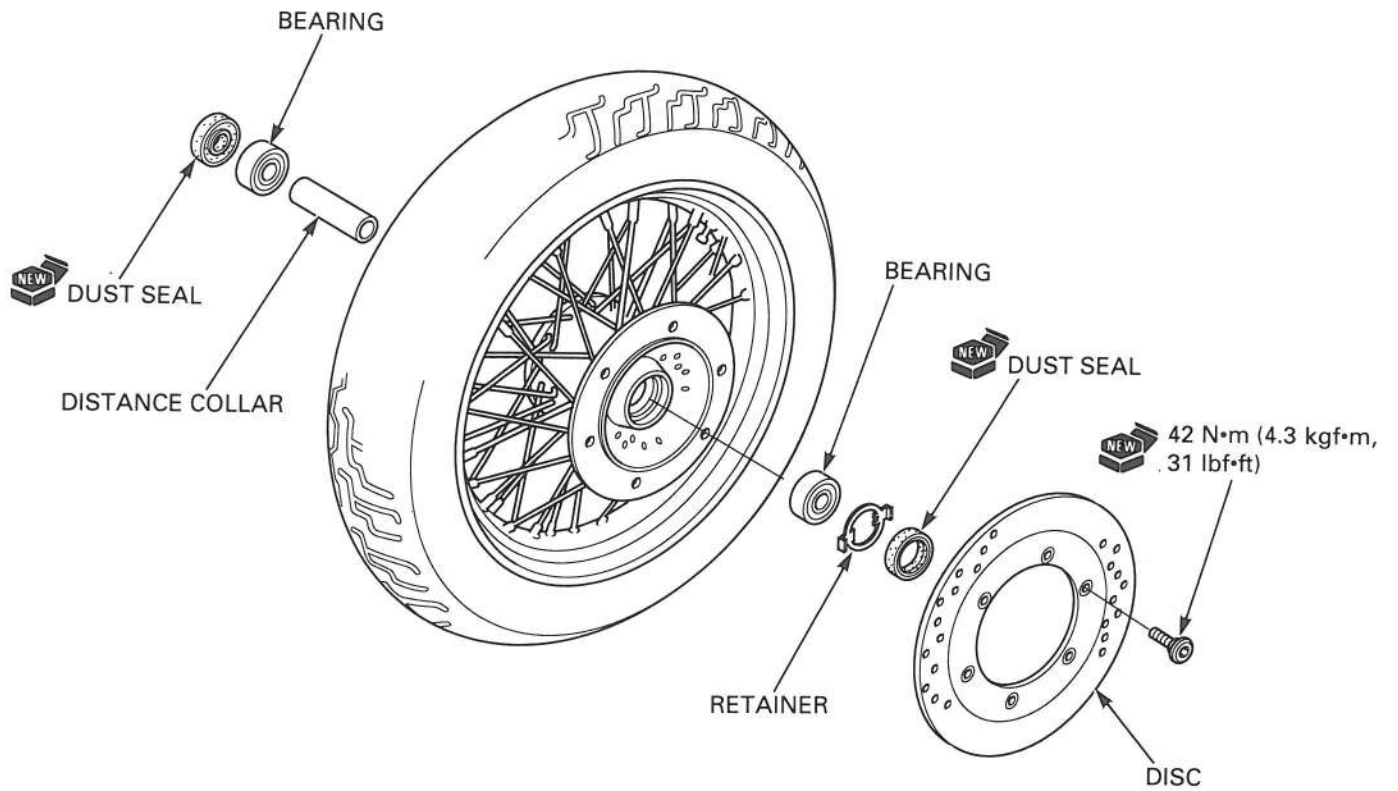

Drive in a new right bearing squarely with the marking side facing up until it is fully seated.
Install the distance collar.
Drive in a new left bearing squarely with the marking side facing up until it is fully seated.

TOOLS:

- | | |
|-------------------------------|------------------------|
| Driver | 07749 - 0010000 |
| Attachment, 42 X 47 mm | 07746 - 0010300 |
| Pilot, 20 mm | 07746 - 0040500 |

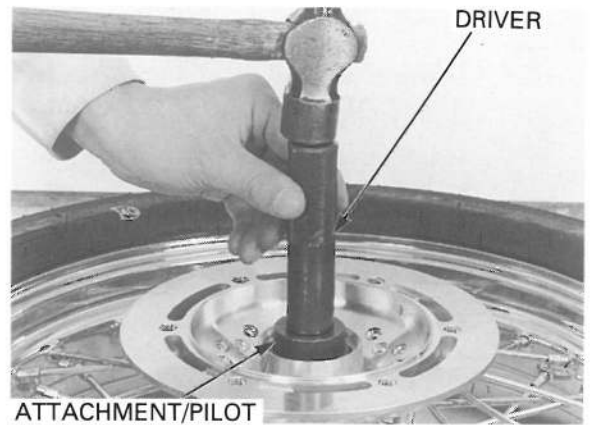

Assemble the wheel as follows if the wheel is disassembled.
Clean the spoke nipple threads.
Measure the hub width B.
Calculate the distance A as following:

$$A = 79 \text{ mm} - B/2$$

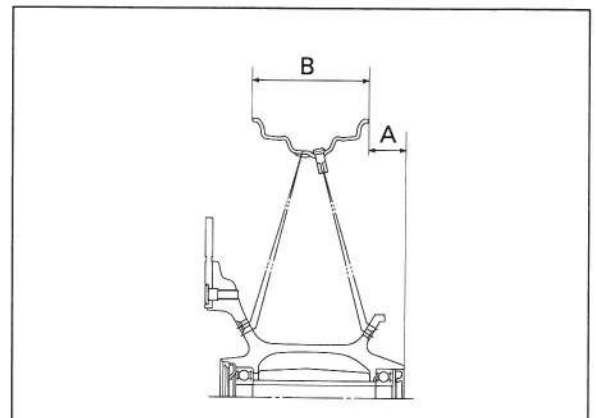

FRONT WHEEL/SUSPENSION/STEERING

Adjust the rim position and distance A by tightening the spokes to the specified torque in 2 or 3 progressive steps.

TOOL:

Spoke wrench **07JMA – MR60100**
or equivalent commercially
available in U.S.A.

TORQUE: 4 N•m (0.4 kgf•m, 2.9 lbf•ft)

Check the rim runout (page 13-15).

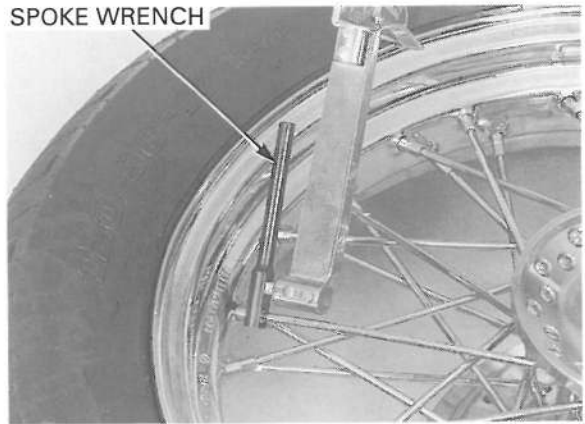

Install the brake disc with the "MIN. TH. 5mm" marked side facing out.



*Tighten the bolts in
a crisscross pattern
in 2 or 3 steps.*

Install and tighten the new brake disc bolts to the specified torque.

TORQUE: 42 N•m (4.3 kgf•m, 31 lbf•ft)

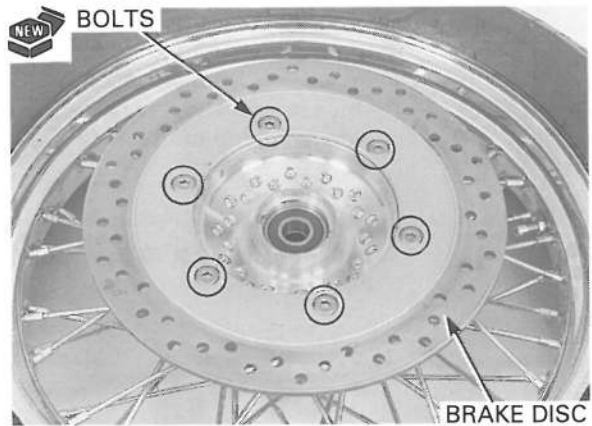

WHEEL BALANCE

⚠ WARNING

Wheel balance directly affects the stability, handling and overall safety of the motorcycle. Carefully check balance before reinstalling the wheel.

NOTE:

- The wheel balance must be checked when the tire is remounted.
- For optimum balance, the tire balance mark (a paint dot on the side wall) must be located next to the valve stem. Remount the tire if necessary.

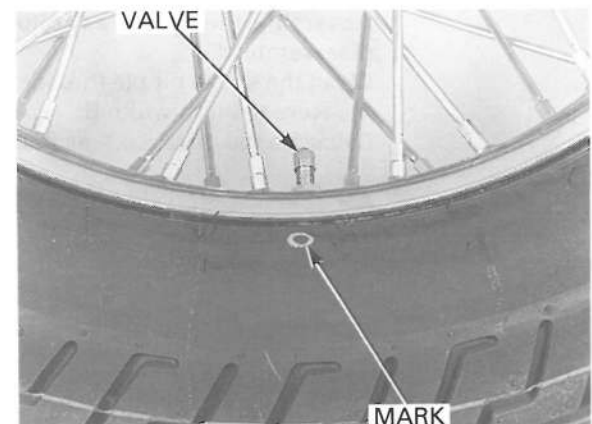

Mount the wheel, tire and brake disc assembly on an inspection stand.

Spin the wheel, allow it to stop, and mark the lowest (heaviest) part of the wheel with chalk.

Do this two or three times to verify the heaviest area. If the wheel is balanced, it will not stop consistently in the same position.

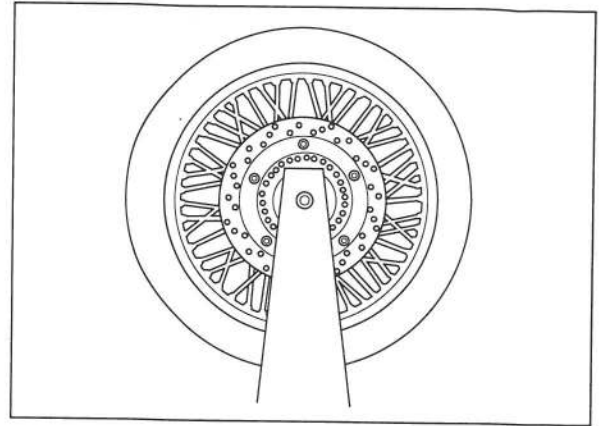

To balance the wheel, install balance weights on the lightest side of rim, the side opposite the chalk marks.

Add just enough weight so the wheel will no longer stop in the same position when it is spun.

Do not add more than 60 g (2.1 oz) to the front wheel.

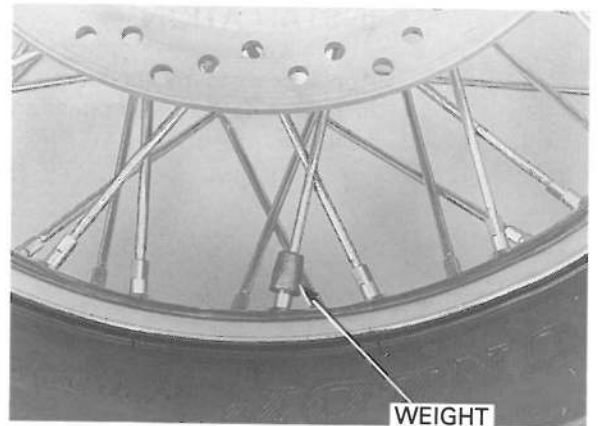

Install the speedometer gear retainer to the wheel hub by aligning the tangs on the retainer with the slots on the hub.

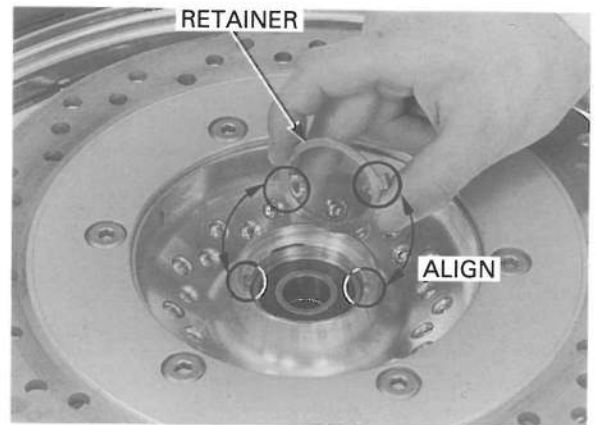

⚠ WARNING

Do not get grease on the brake disc or stopping power will be reduced.

Apply grease to the new left dust seal lip. Install the dust seals to the left wheel hub.

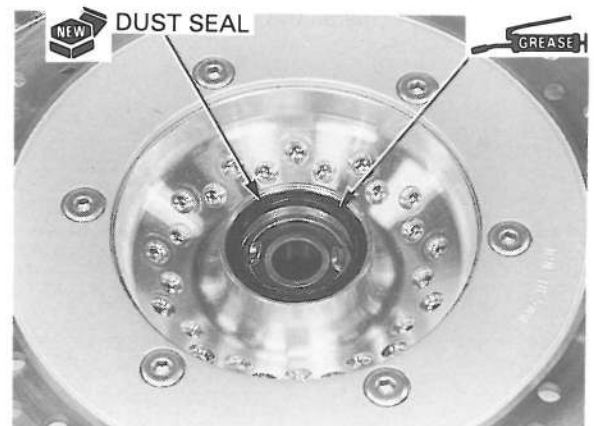

FRONT WHEEL/SUSPENSION/STEERING

Apply grease to the new right dust seal lip.
Install the dust seal to the right wheel hub.

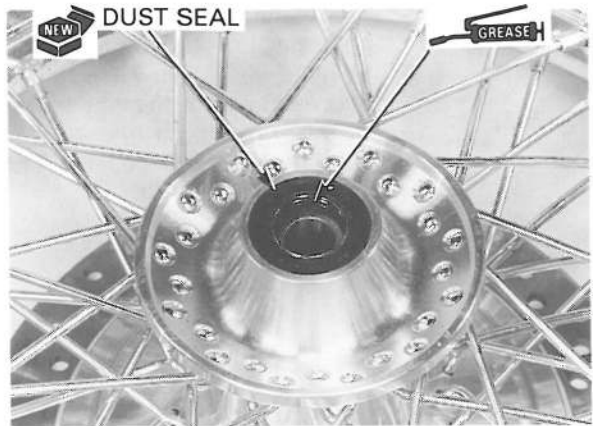

INSTALLATION

Apply grease to the speedometer gear box and gear.
Install the speedometer gear and washers into the gear box.

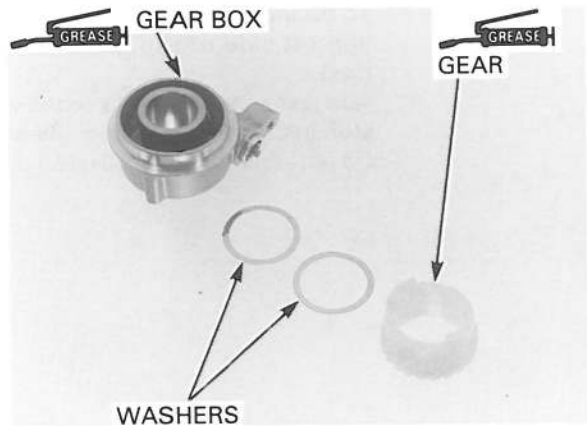

Install the speedometer gear box into the left wheel hub by aligning the tangs with the slots.

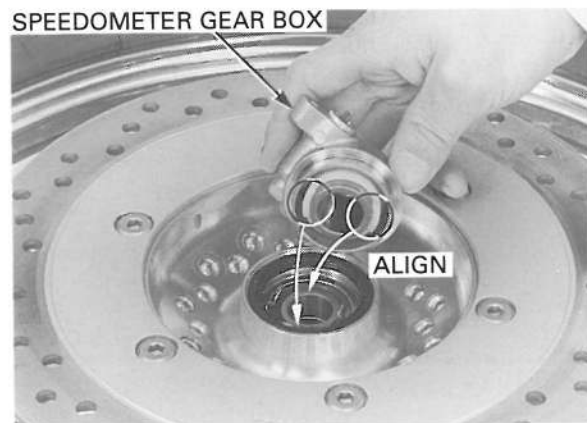

Install the side collar into the right wheel hub.



FRONT WHEEL/SUSPENSION/STEERING

Install the front wheel between the fork legs so that the brake disc is positioned between the pads, being careful not to damage the pads.

Apply thin coat of grease to the front axle.
Install the front axle.

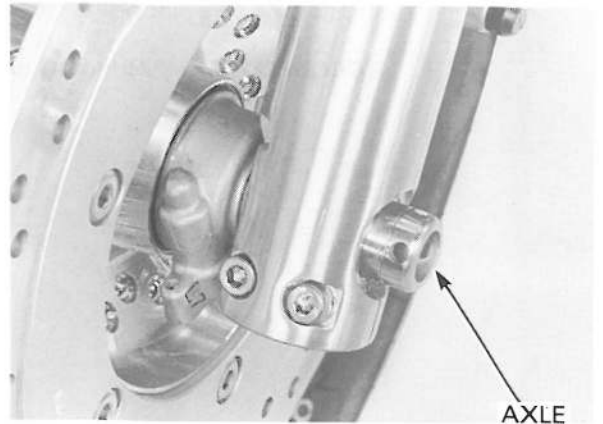

Position the lug on the speedometer gear box against the back of the stopper on the fork leg.

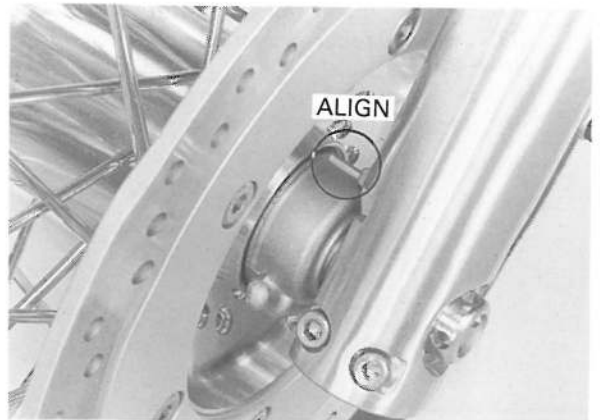

Install and tighten the front axle bolt to the specified torque.

TORQUE: 59 N·m (6.0 kgf·m, 43 lbf·ft)



With the front brake applied, pump the front suspension up and down several times to seat the axle and check front brake operation.

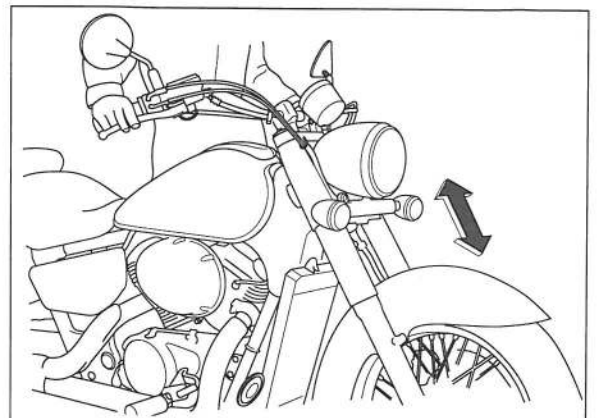

FRONT WHEEL/SUSPENSION/STEERING

Tighten the axle pinch bolts to the specified torque.

TORQUE: 22 N·m (2.2 kgf·m, 16 lbf·ft)

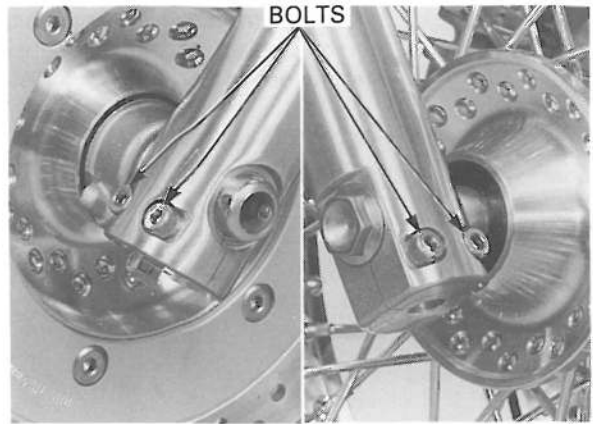

VT750C and VT750CD/CD2 (98-2000): Install the speedometer cable and tighten the screw securely.

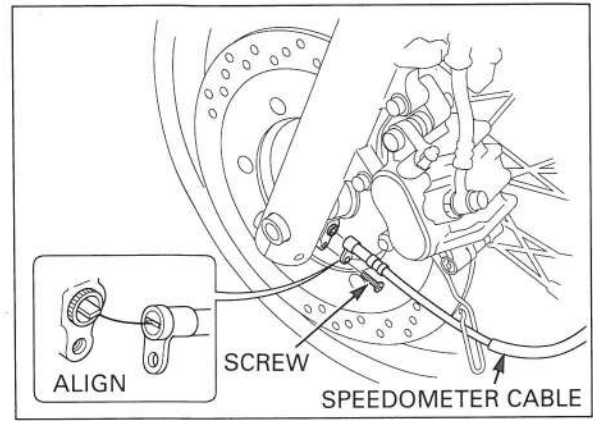

VT750C3/CD3 and VT750CD/CD2 (after 2000): Install the speed sensor and tighten the screw securely.

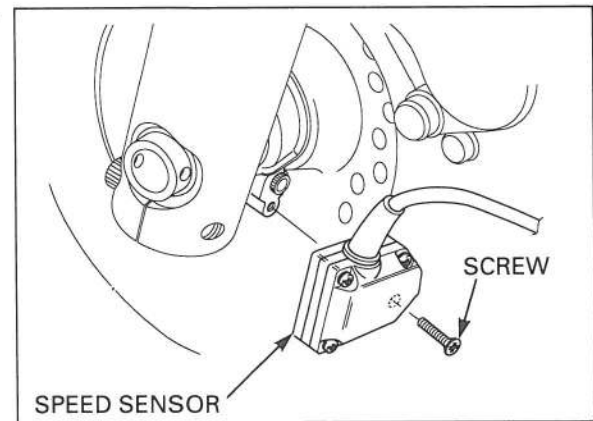

FORK

REMOVAL

Remove the front wheel (page 13-13).

Remove the four bolts.
Remove the brake hose clamp and front fender.

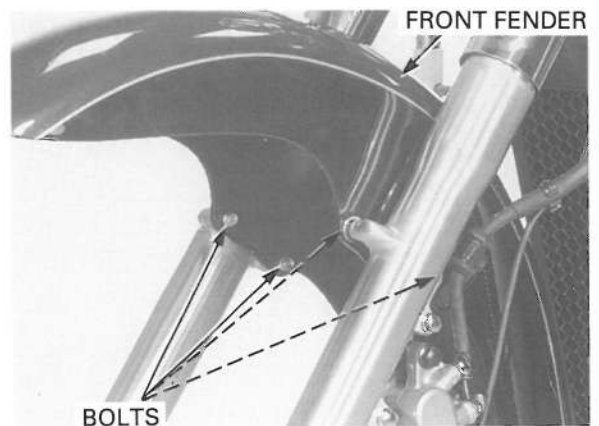

NOTE:

Do not operate the front brake lever after removing the front wheel. To do so will cause difficulty in fitting the brake disc between the brake pads.

Remove the brake caliper mounting bolts and brake caliper.

CAUTION:

- *Do not suspend the brake caliper from the brake hose.*
- *Do not twist the brake hose.*

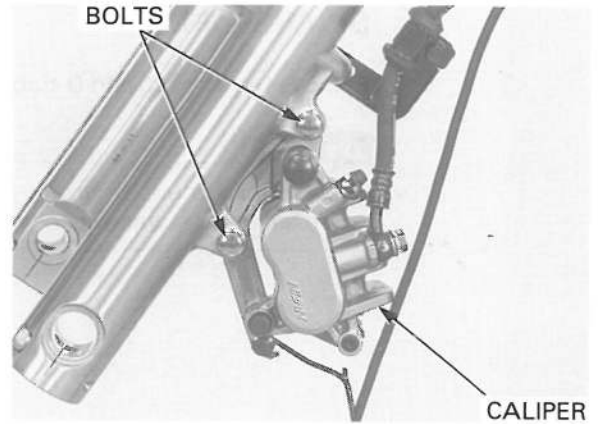

Loosen the fork top bridge pinch bolt. When the fork is ready to be disassembled, loosen the fork cap, but do not remove it.

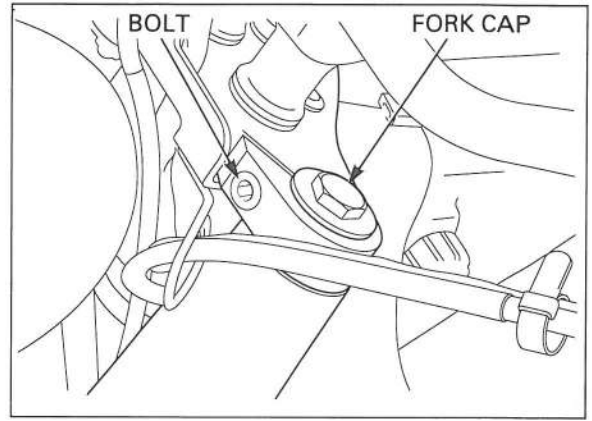

VT750CD/CD2/CD3: Remove the top bridge (page 13-35).

Remove the O-ring, bolts and upper fork cover.

NOTE:

Do not apply soapsuds or oil to the fork cover inner surface when removing the fork cover.

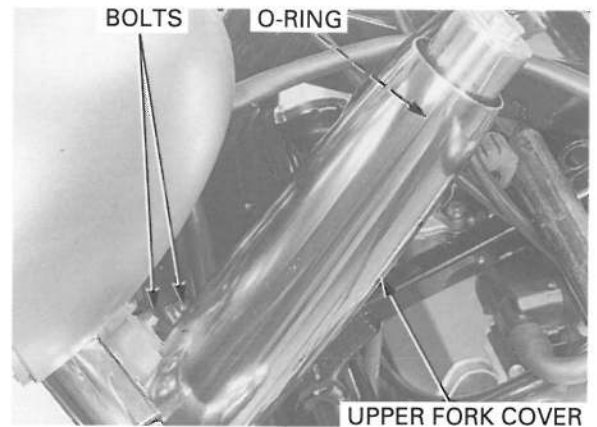

Loosen the fork bottom bridge pinch bolt while holding the fork. Remove the front fork.

VT750CD/CD2/CD3: Remove the lower fork cover from the steering stem.

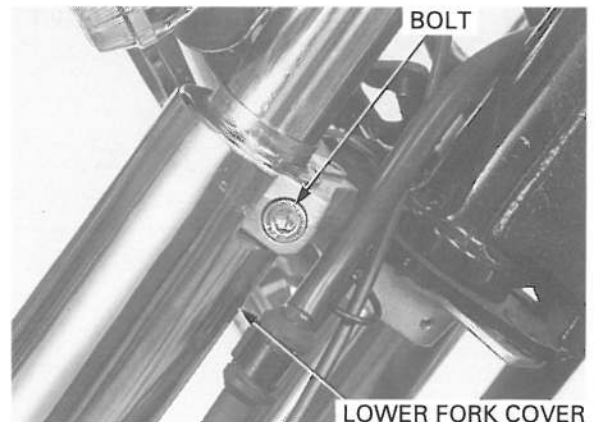

FRONT WHEEL/SUSPENSION/STEERING

DISASSEMBLY

Remove the fork cap and O-ring from the fork tube.

⚠ WARNING

The fork cap is under spring pressure. Use care when removing it and wear eye and face protection.

FORK CAP/O-RING

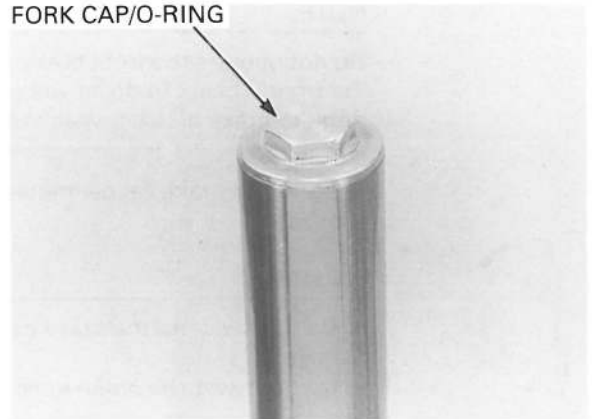

Remove the spring spacer and washer from the fork tube.

SPACER



WASHER

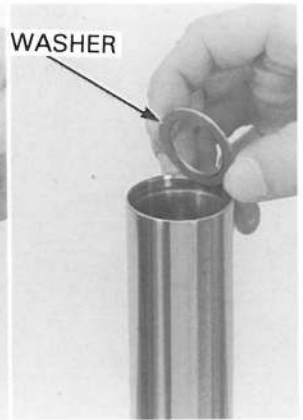

Remove the fork spring.

SPRING

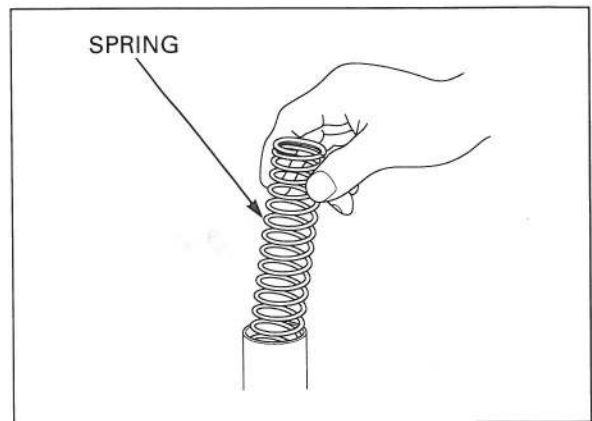

Pour the fork oil from the fork leg by pumping the fork 8-10 times.

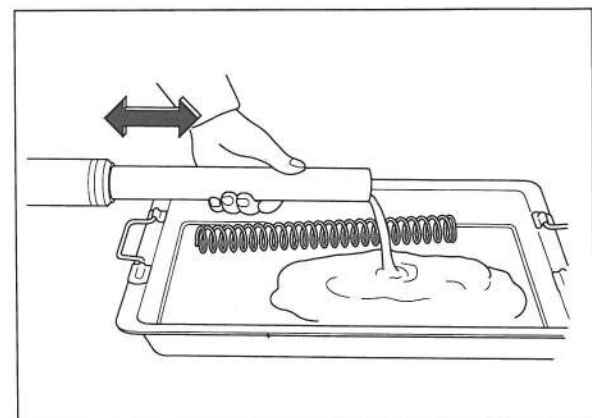

CAUTION:

Do not over tighten the fork slider.

Hold the axle holder in a vise with a piece of wood or soft jaws to avoid damage.

Loosen and remove the fork socket bolt and sealing washer from the fork slider.

If the fork piston turns with the socket bolt, temporarily install the fork spring, washer, spring spacer and fork cap.



SOCKET BOLT/SEALING WASHER

Do not remove the fork piston ring, unless it is necessary to replace with a new one.

Remove the fork piston and rebound spring.

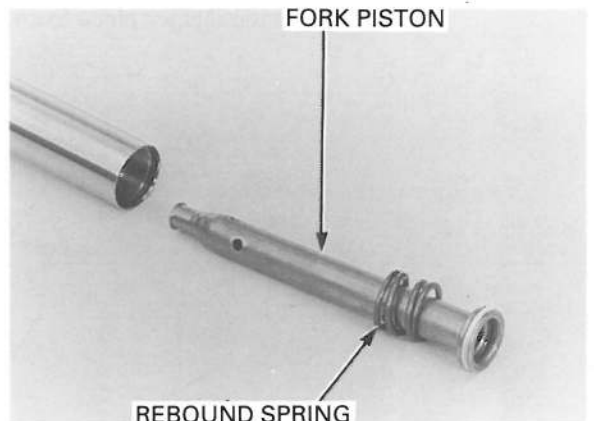

Remove the dust seal from the fork slider.

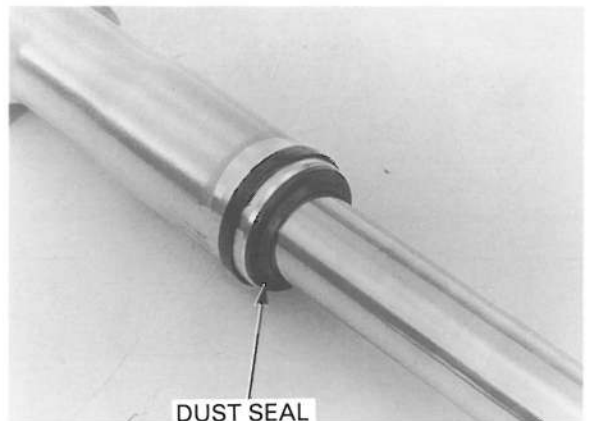

Remove the stopper ring from the groove of the fork slider.

CAUTION:

Do not scratch the fork tube sliding surface.

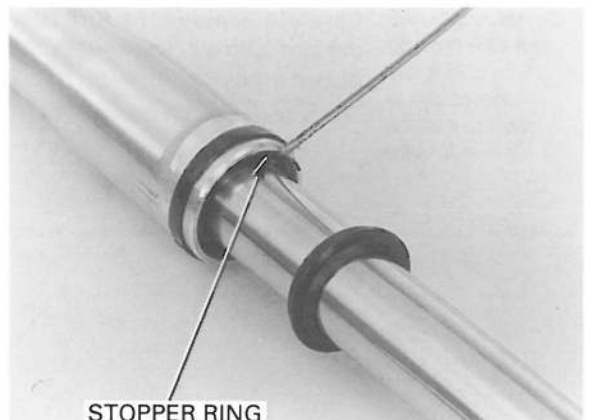

FRONT WHEEL/SUSPENSION/STEERING

NOTE:

Check that the fork tube moves smoothly in the fork slider. If does not, check the fork tube for bending or damage, and bushings for wear or damage.

Using quick successive motions, pull the fork tube out of the fork slider.

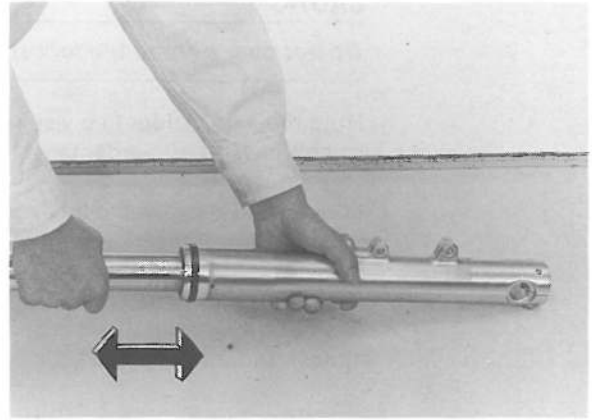

Remove the oil lock piece from the fork slider.

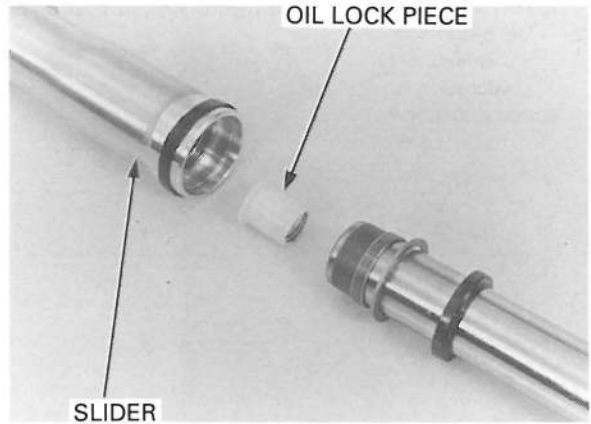

Remove the oil seal, back-up ring and slider bushing from the fork tube.

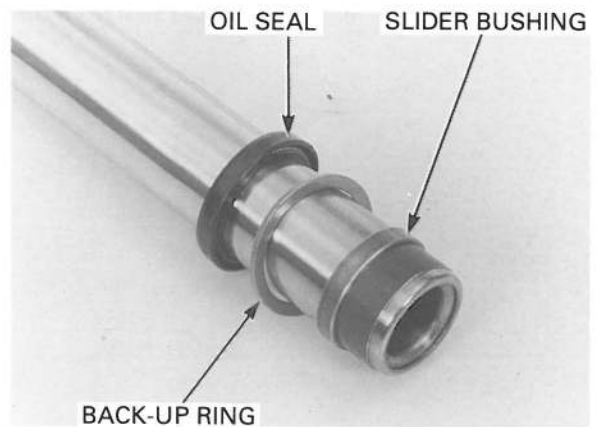

Do not remove the fork tube bushing unless it is necessary to replace it with a new one.

Carefully remove the fork tube bushing by prying the slot with a screwdriver until the bushing can be pulled off by hand.

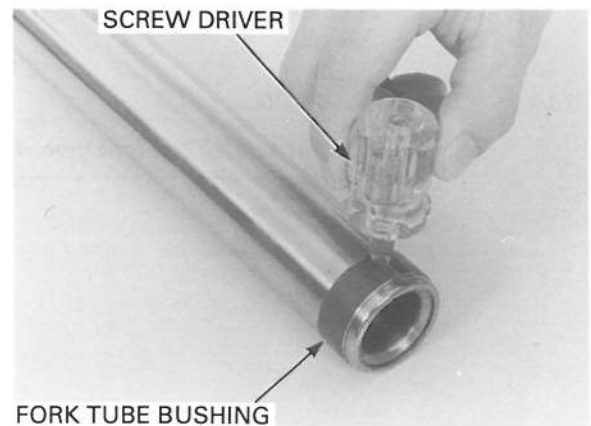

INSPECTION

FORK SPRING

Measure the fork spring free length by placing the spring on a flat surface.

SERVICE LIMIT: 297.3 mm (11.70 in)

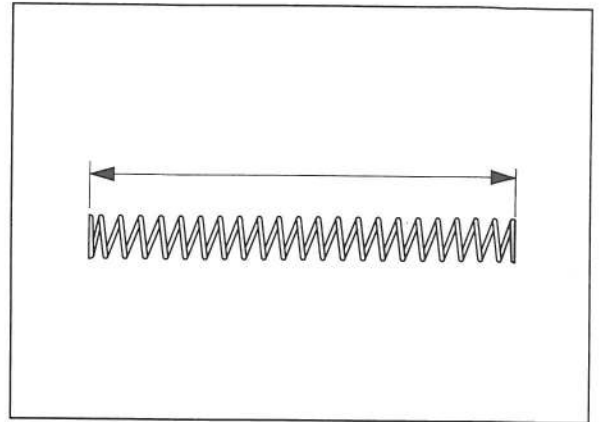

FORK TUBE/SLIDER/FORK PISTON

Check the fork tube, slider and fork piston for score marks, and excessive or abnormal wear.

Replace the component if necessary.

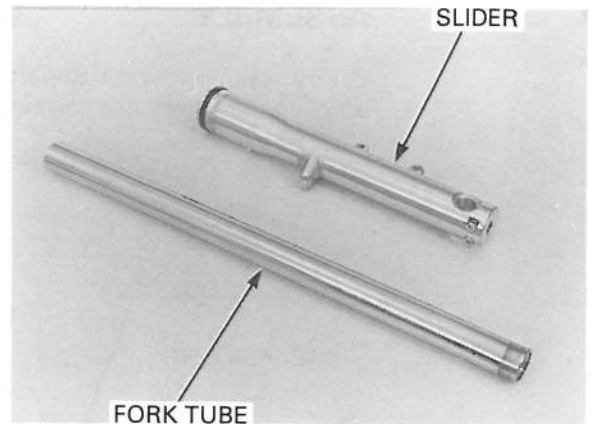

Check the fork piston ring for wear or damage.
Check the rebound spring for fatigue or damage.

Replace the component if necessary.

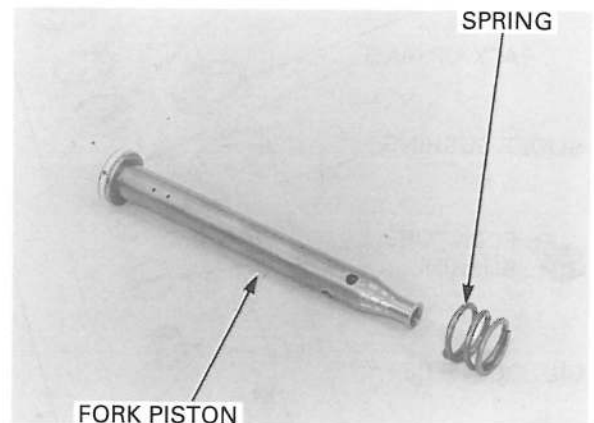

Set the fork tube in V-blocks and measure the fork tube runout rotating it with a dial indicator.
Actual runout is 1/2 the total indicator reading.

SERVICE LIMIT: 0.2 mm (0.008 in)

Replace if the service limit is exceeded, or there are scratches or nicks that will allow fork oil to leak past the seals.

NOTE:

Do not reuse the fork tube if it cannot be perfectly straightened with minimal effort.

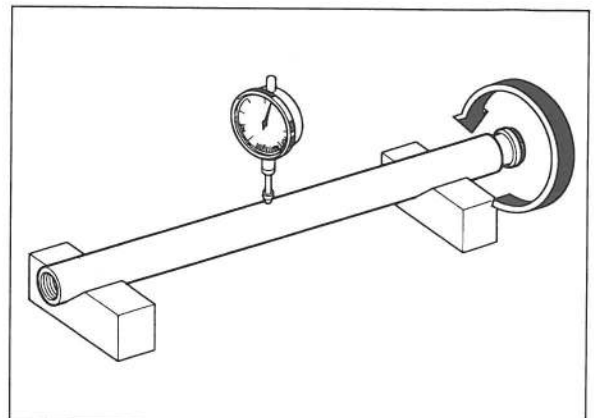

FRONT WHEEL/SUSPENSION/STEERING

FORK TUBE BUSHING

Visually inspect the slider and fork tube bushings. Replace the bushings if there is excessive scoring or scratching, or if the teflon is worn so that the copper surface appears on more 3/4 of the entire surface.

Check the back-up ring; replace it if there is any distortion at the point shown.

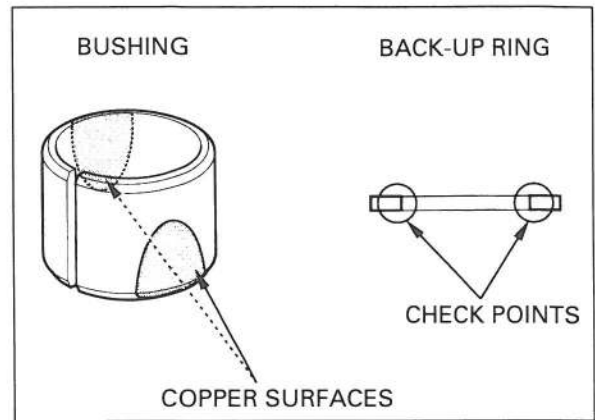

ASSEMBLY

Before assembly, wash all parts with a high flash point or non-flammable solvent and wipe them off completely.

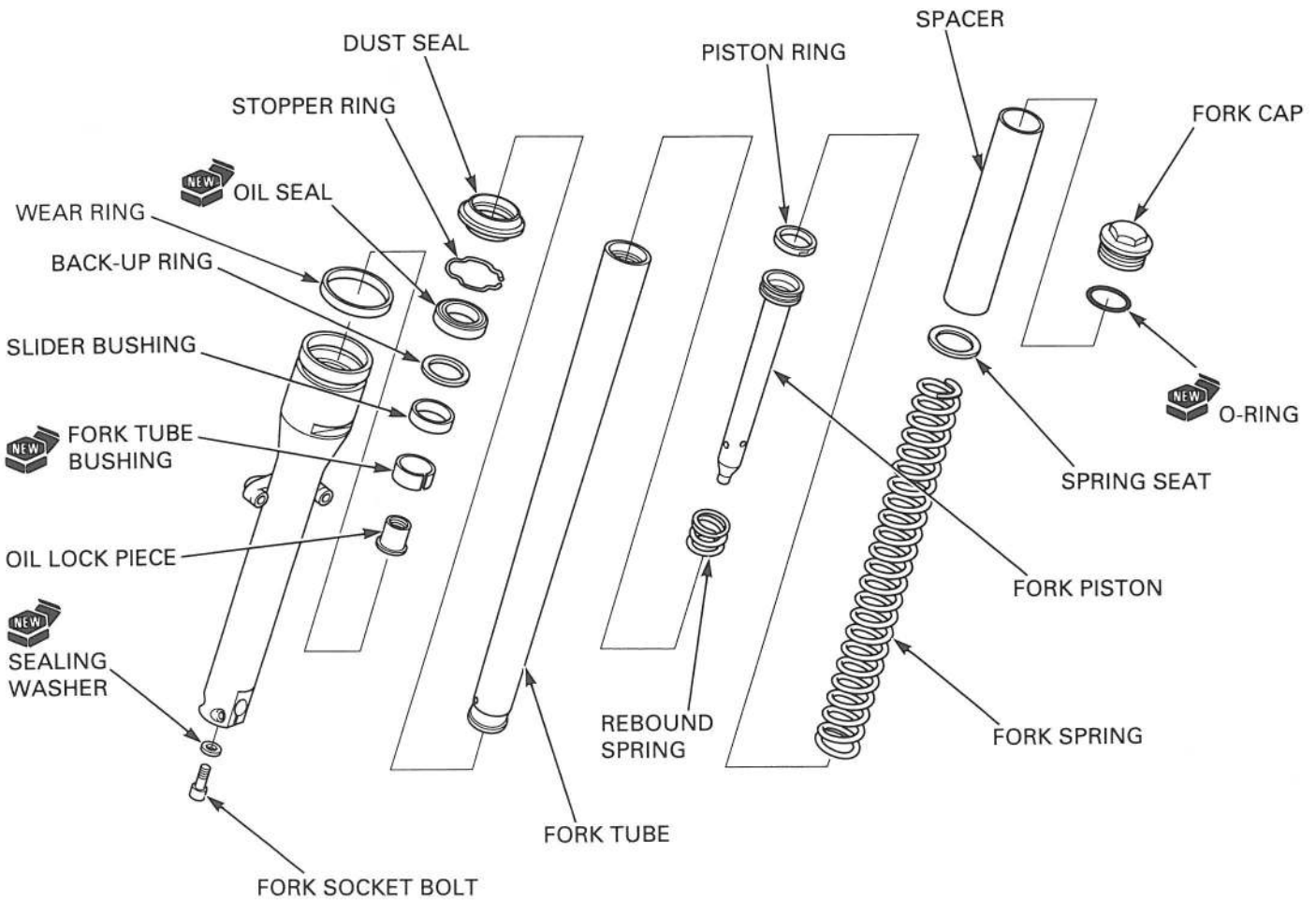

Install a new fork tube bushing if the tube bushing has been removed.

CAUTION:

- *Be careful not to damage the fork tube bushing coating.*
- *Do not open the fork tube bushing more than necessary.*

NOTE:

Remove the burrs from the bushing mating surface, being careful not to peel off the coating.

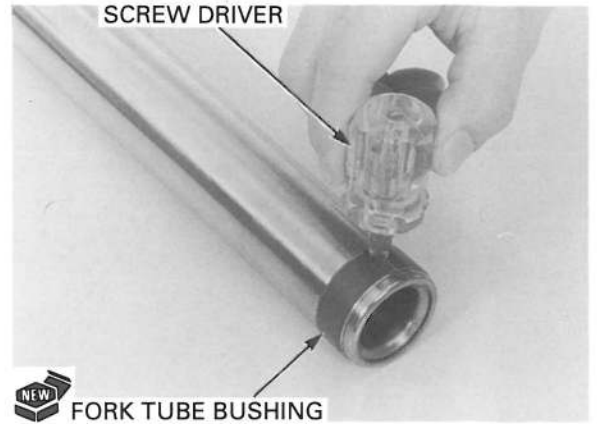

Install the slider bushing and back-up ring to the fork tube.

Apply fork oil to the new oil seal lip.

Install the new oil seal to the fork tube with it marking side facing up.

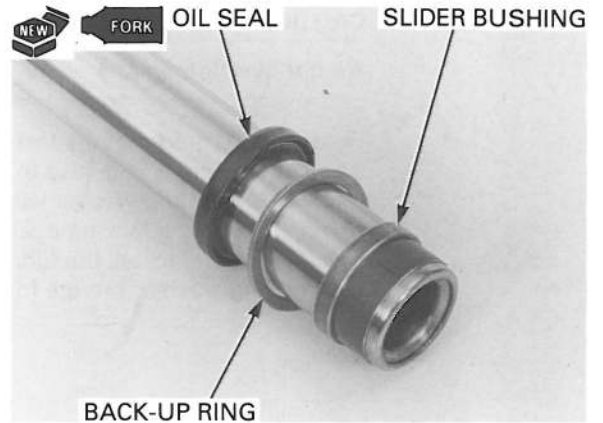

Install the oil lock piece onto the fork piston end. Coat the fork tube bushing with fork oil and install the fork into the fork slider.

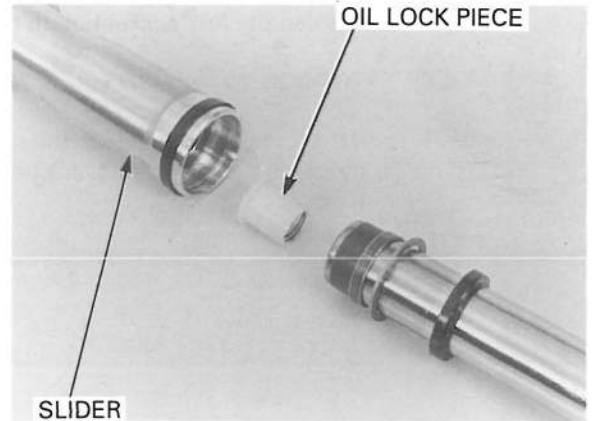

Install the rebound spring to the fork piston.

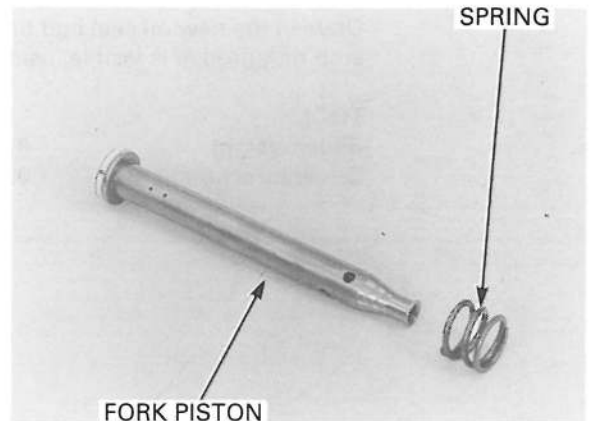

FRONT WHEEL/SUSPENSION/STEERING

Install the fork piston into the fork tube.

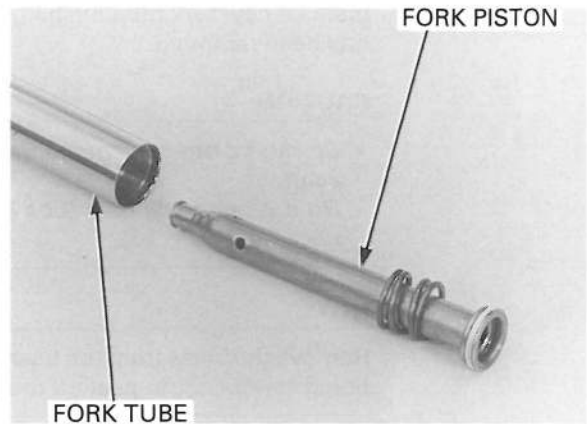

CAUTION:

Do not overtighten fork slider.

Hold the axle holder of the fork slider in a vise with a piece of wood or soft jaws to avoid damage. Replace the sealing washer with a new one. Clean and apply a locking agent to the fork socket bolt threads and install the fork socket bolt with the new sealing washer into the fork piston.

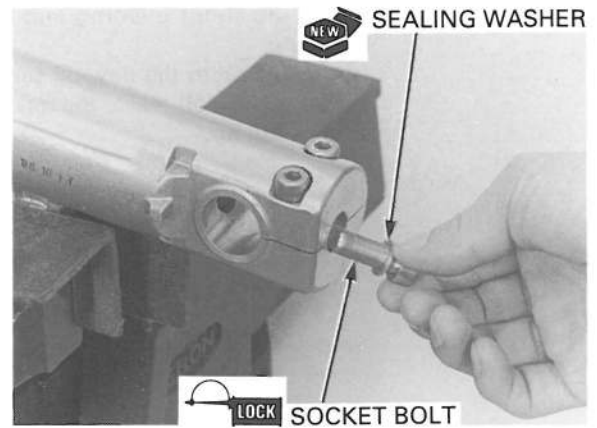

Tighten the fork socket bolt to the specified torque.

TORQUE: 29 N·m (3.0 kgf·m, 22 lbf·ft)

If the fork piston turns with the socket bolt, temporarily install the fork spring, washer, spring spacer and fork cap.

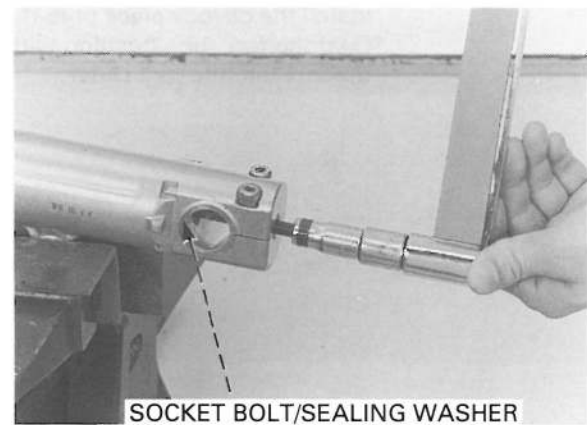

Drive in the new oil seal into the fork tube until the stop ring groove is visible, using the special tool.

TOOL:

Slider weight	07947-KA50100
Driver attachment set	07947-KF00100

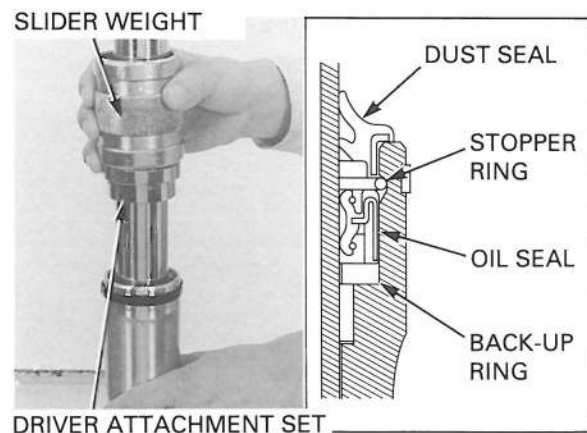

Install the stopper ring into the groove in the fork slider.

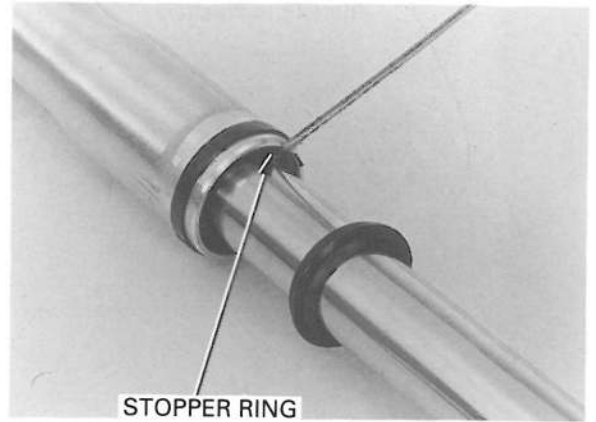

Apply fork oil to the lip of a new dust seal and install the dust seal.

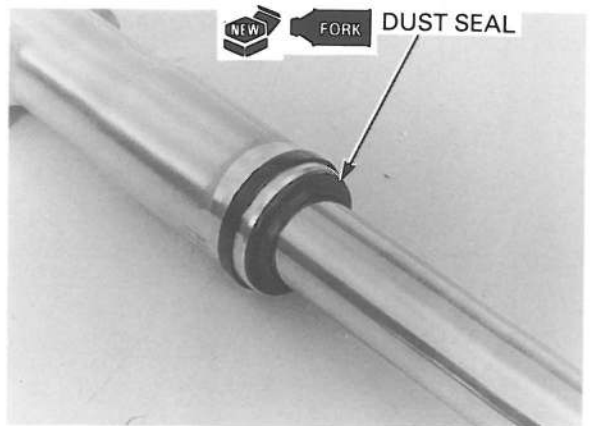

Pour half the required amount of the recommended fork oil in the fork tube.

RECOMMENDED FORK OIL:
Pro-Honda Suspension Fluid SS-8 or equivalent
OIL CAPACITY:
514 ± 2.5 cm³ (17.4 ± 0.08 US oz, 18.0 ± 0.09 Imp oz)

Slowly pump the fork tube several times to remove trapped air.
Pour additional oil up to the specified capacity and repeat the above step.
Compress the fork leg fully.
Measure the oil level from the top of the fork tube.

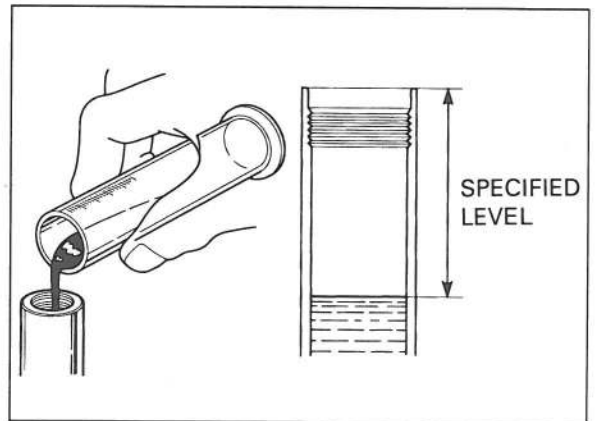

OIL LEVEL: 108 mm (4.3 in)

Install the fork spring into the fork tube.

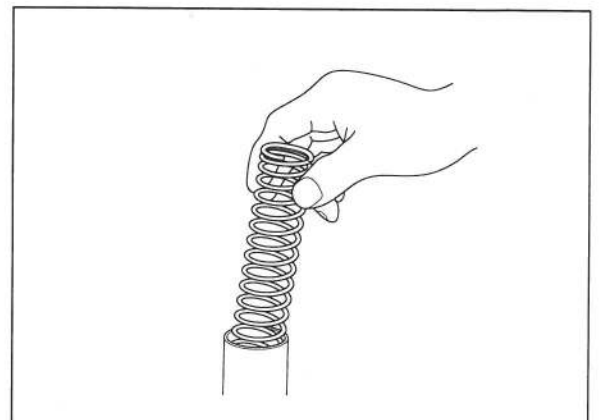

FRONT WHEEL/SUSPENSION/STEERING

Install the washer.



Install the spring spacer.

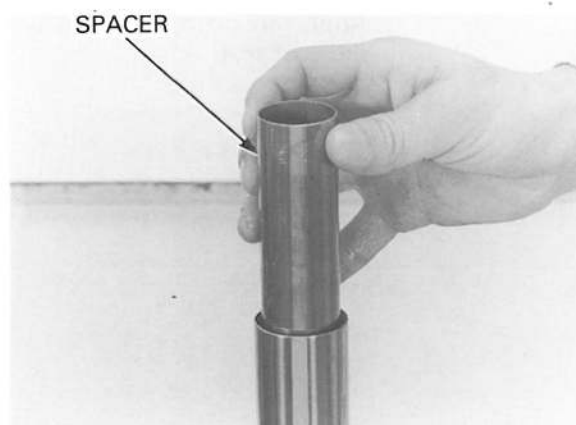

Apply fork oil to the new O-ring and install the new O-ring to the fork cap.
Install the fork cap into the fork tube.

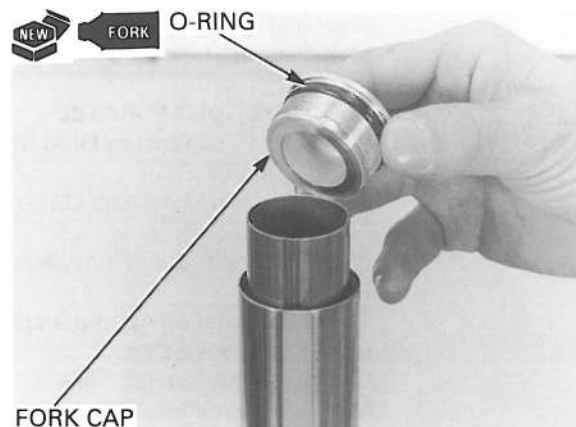

NOTE:

Tighten the fork cap after installing the fork tube into the fork bridge.

INSTALLATION

VT750CD/CD2/CD3: Install the lower fork cover to the steering stem.

Install the front fork to the steering stem, then tighten the bottom bridge pinch bolt to temporarily hold the fork in place.

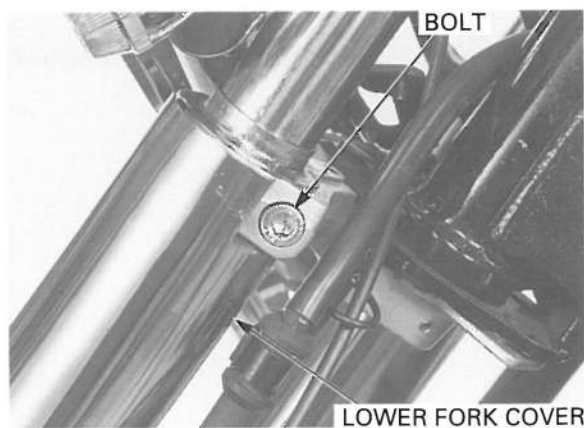

FRONT WHEEL/SUSPENSION/STEERING

VT750CD/CD2/CD3: Install the upper fork cover to the front fork. Install and tighten the bolts securely. Install the O-ring into the fork cover as shown.

NOTE:

Do not apply soapsuds or oil to the fork cover inner surface when removing the fork cover.

Install the top bridge (page 13-42).

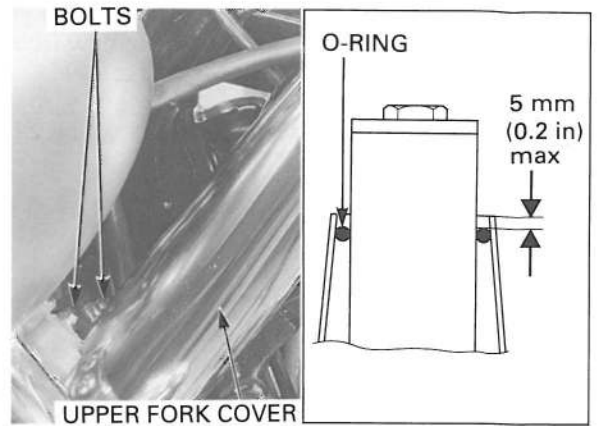

Loosen the bottom bridge pinch bolt.

Align the top of fork tube with the upper surface of the top bridge.

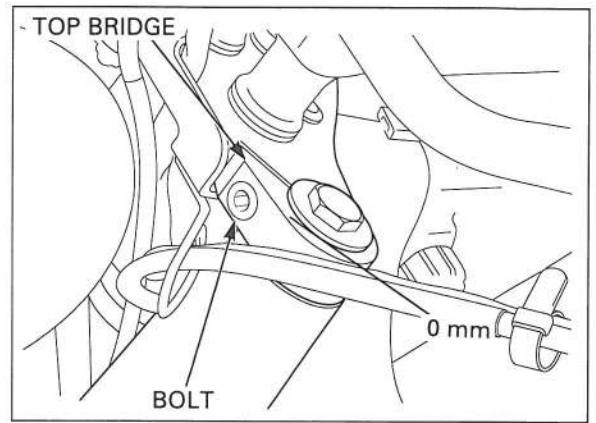

Tighten the bottom bridge pinch bolt to the specified torque.

TORQUE: 49 N·m (5.0 kgf·m, 36 lbf·ft)

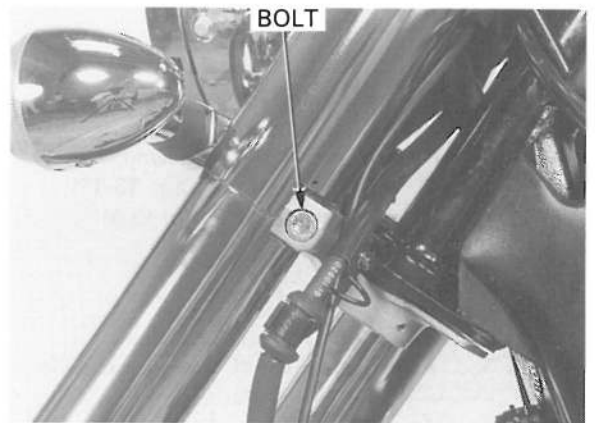

Tighten the fork cap to the specified torque, if removed.

TORQUE: 22 N·m (2.2 kgf·m, 16 lbf·ft)

Tighten the top bridge pinch bolts to the specified torque.

TORQUE: 26 N·m (2.7 kgf·m, 20 lbf·ft)

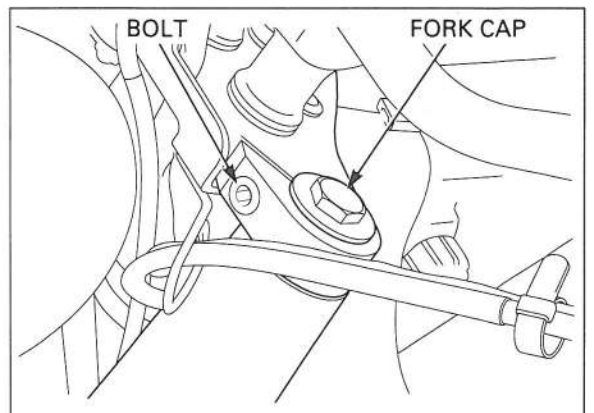

FRONT WHEEL/SUSPENSION/STEERING

Install the brake caliper to the left front fork.
Install and tighten the new front caliper mounting bolts to the specified torque.

TORQUE: 30 N·m (3.1 kgf·m, 22 lbf·ft)

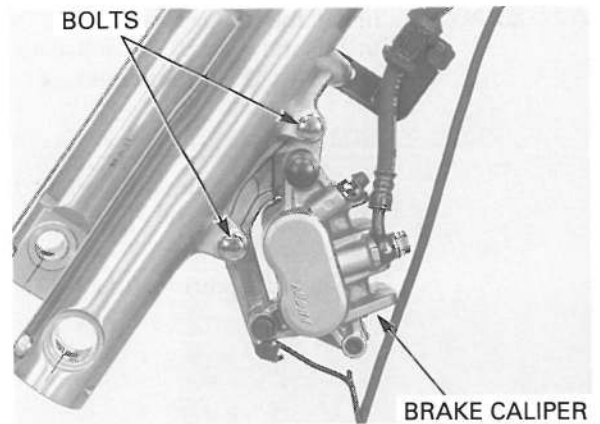

Install the front fender with the brake hose clamp.
Install and tighten the mounting bolts securely.

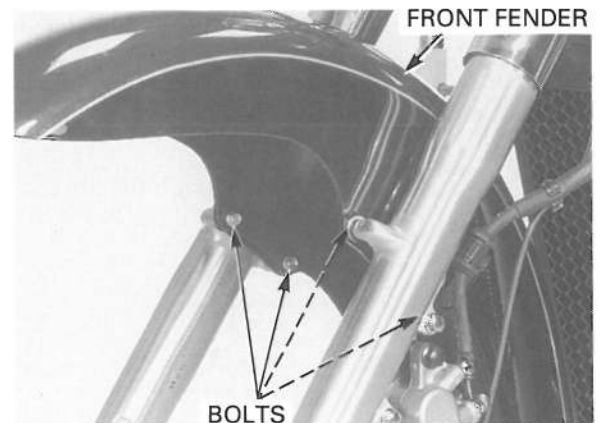

STEERING STEM

REMOVAL

If the handlebar lower holders will be removed, loosen the lower holder nuts before removing the upper holders.

Remove the following:
– Front wheel (page 13-13)
– Handlebar (page 13-6)

VT750C and VT750CD/CD2 ('98 – 2000):

Disconnect the speedometer cable from the speedometer.
Remove the speedometer stay mounting bolts.
Remove the speedometer and stay as an assembly.

Remove the nuts, washers and handlebar lower holders.

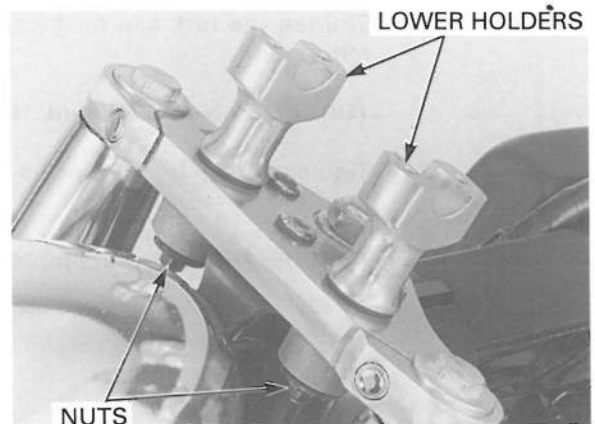
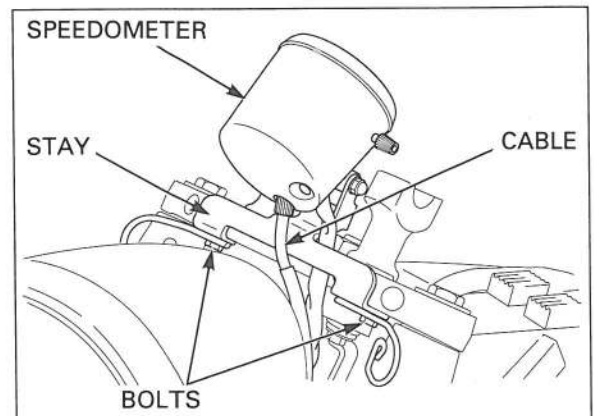

Remove the bushings.

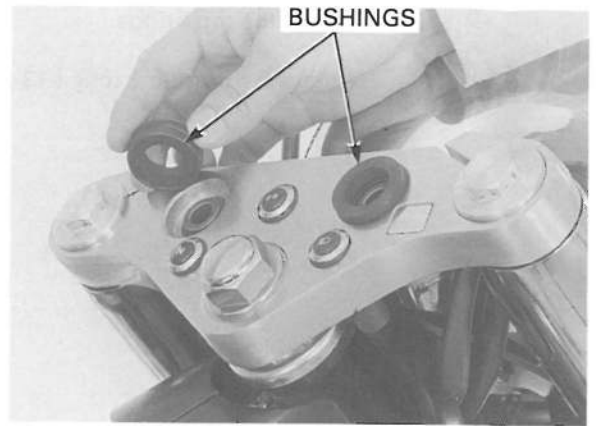

Remove the bolt and brake hose guide.

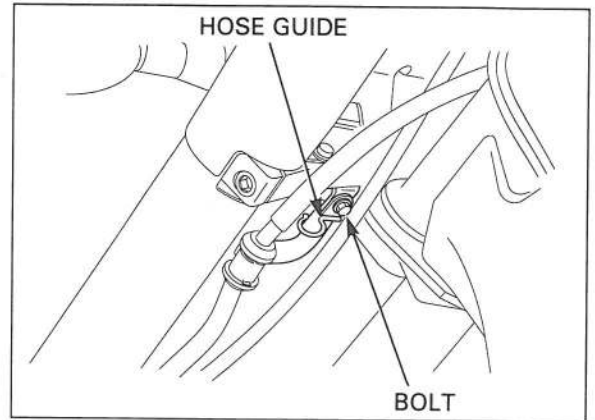

Remove the headlight (page 19-7).
Disconnect the wire connectors.

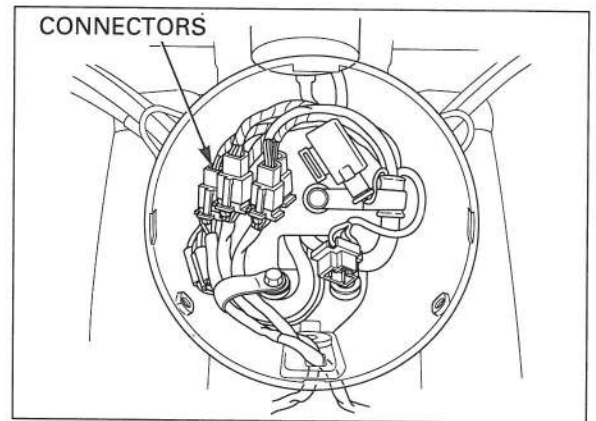

Remove the steering stem nut.

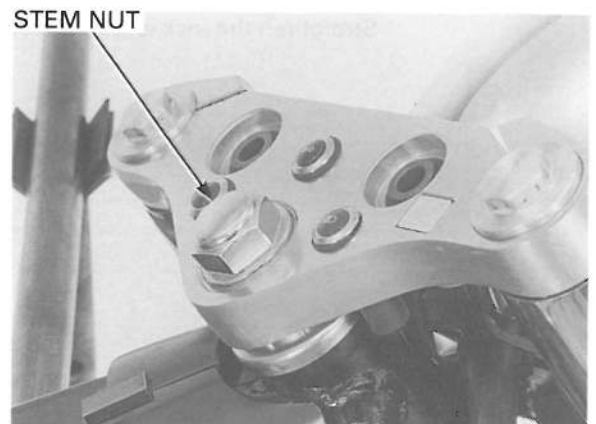

FRONT WHEEL/SUSPENSION/STEERING

Remove the top bridge.

Remove the front fork (page 13-22).

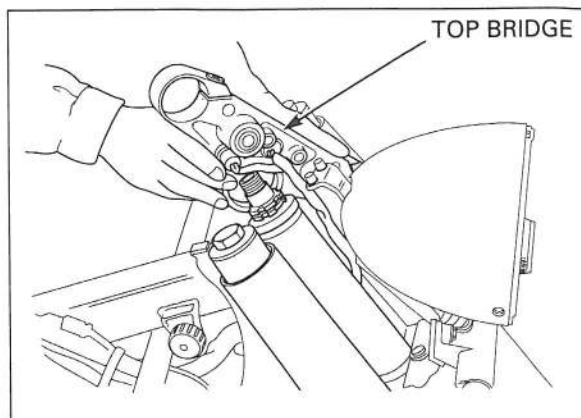

Remove the headlight case and stay from the steering stem.

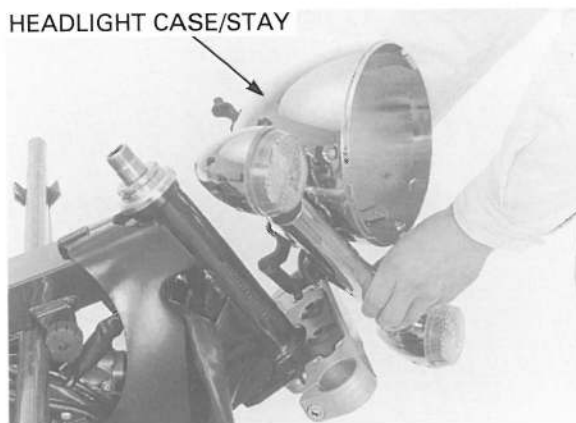

Remove the bolts and steering stem cover.

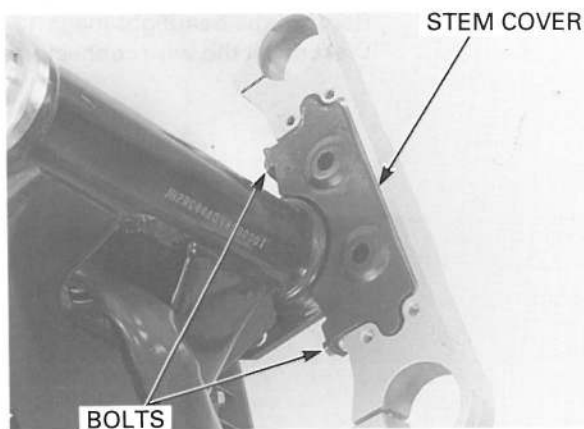

Straighten the lock washer tabs.



Remove the lock nut using following tool.

TOOL:
Steering stem socket **07916-3710101 or**
 07916-3710100

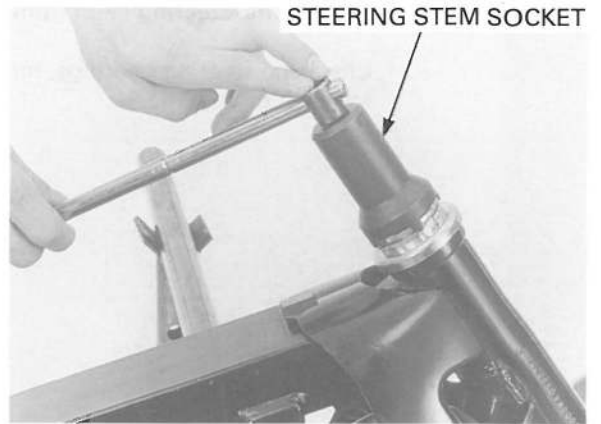

Remove the lock washer.

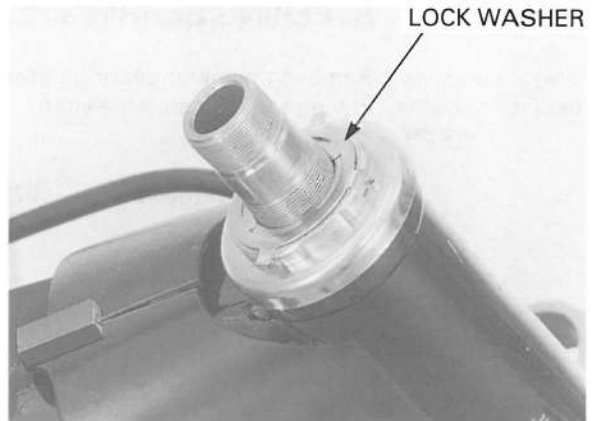

Remove the steering top thread using following tool.

TOOL:
Steering stem socket **07916-3710101 or**
 07916-3710100

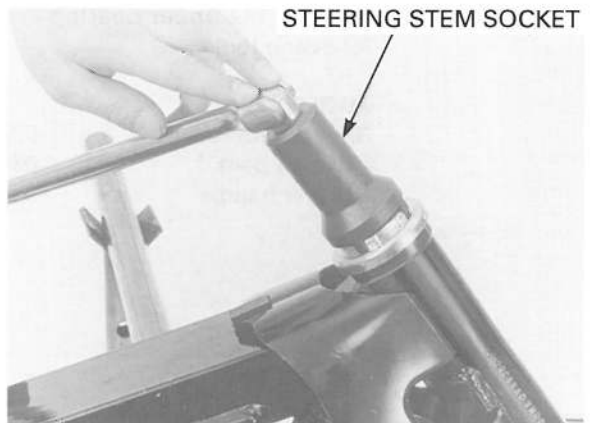

Hold the steering stem by hand and remove the steering top thread, dust seal, upper bearing inner race and upper bearing.

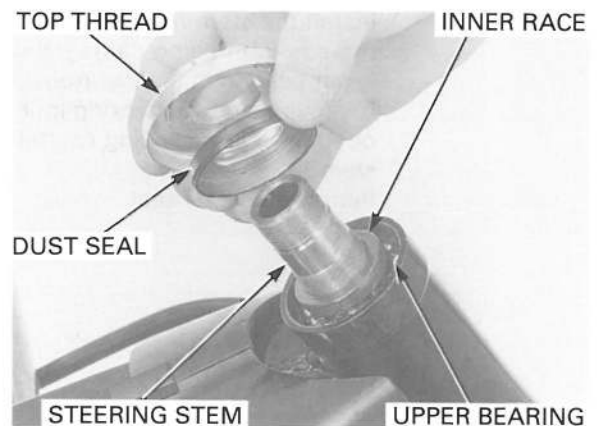

FRONT WHEEL/SUSPENSION/STEERING

Remove the steering stem from the steering head.

Check the steering bearings, inner and outer races for wear or damage.

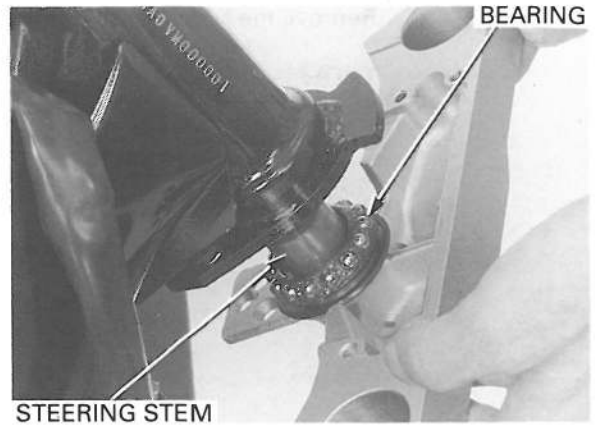

STEERING BEARING REPLACEMENT

Always replace the bearings and races as a set.

Remove the lower bearing outer race using the following tool and suitable shaft.

TOOL:

Bearing race remover 07946-3710500

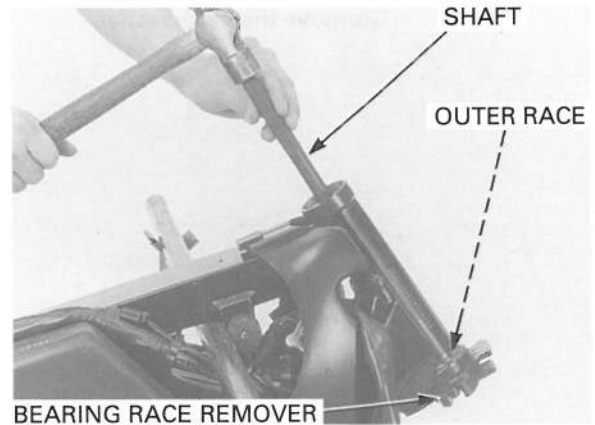

Remove the upper bearing outer race using the following tools.

TOOLS:

Ball race remover 07953-MJ10000
- Attachment 07953-MJ10100
- Driver handle 07953-MJ10200

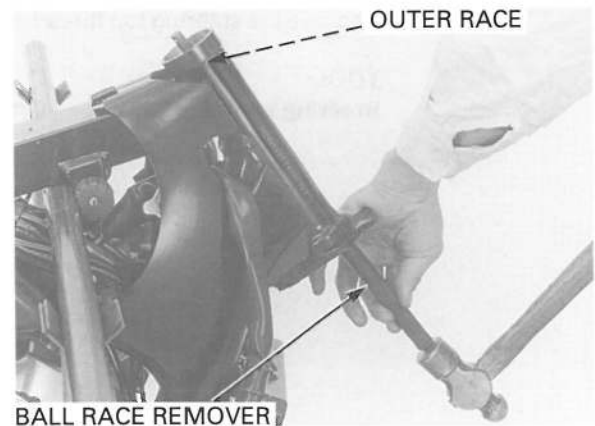

Install the stem nut onto the stem to prevent the threads from being damaged when removing the lower bearing inner race from the stem.

Remove the lower bearing inner race with a chisel or equivalent tool being careful not to damage the stem.

Remove the dust seal.

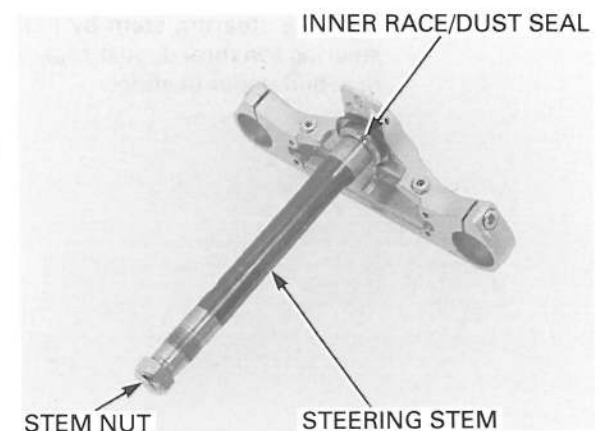

FRONT WHEEL/SUSPENSION/STEERING

Apply grease to the new dust seal lip and install it to the steering stem.
Install the new lower bearing inner race using the following tool and hydraulic press.

TOOL:
Attachment 07746-0030300

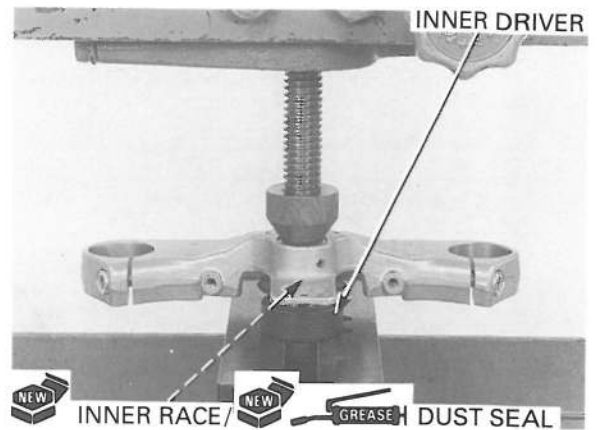

Drive the new upper bearing outer race into the head pipe using the following tools.

TOOLS:
Driver 07749-0010000
Attachment, 42 X 47 mm 07746-0010300

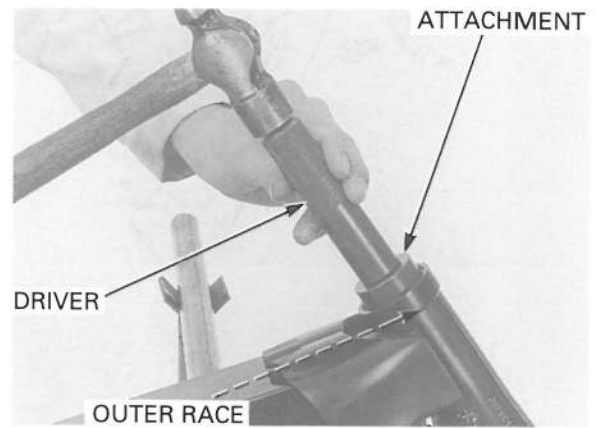

Drive the new lower bearing outer race into the head pipe using the following tools.

TOOLS:
Driver 07749-0010000
Attachment, 52 X 55 mm 07746-0010400

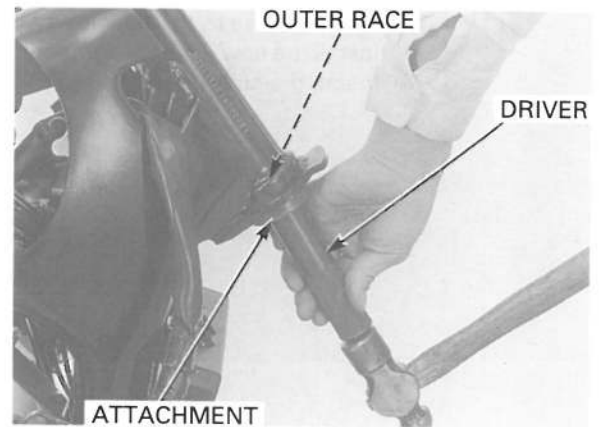

FRONT WHEEL/SUSPENSION/STEERING

INSTALLATION

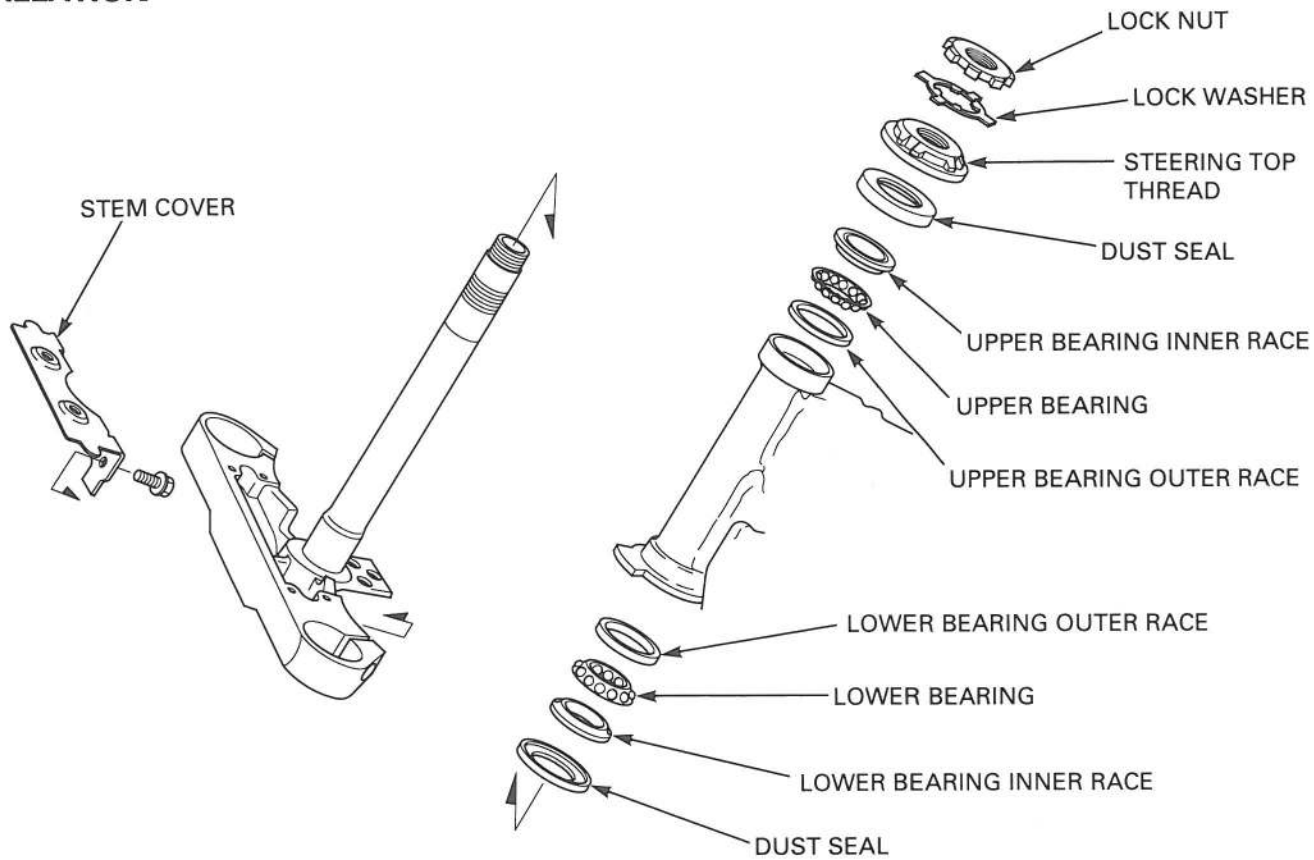

Apply grease to the new lower bearing. Install the new lower bearing onto the steering stem. Install the steering stem into the head pipe.

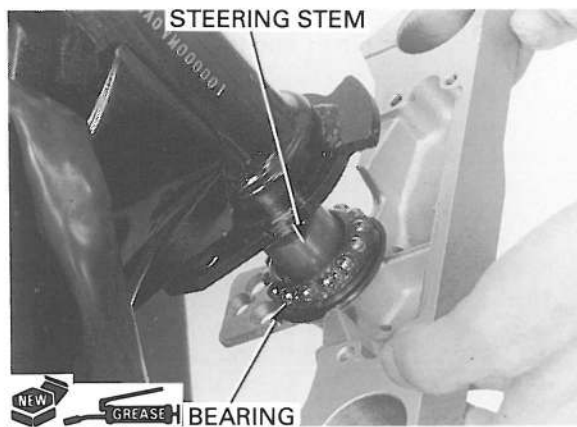

Apply grease to the new upper bearing. Apply oil to the steering top threads. Install the upper bearing, upper bearing inner race, dust seal and steering top thread.

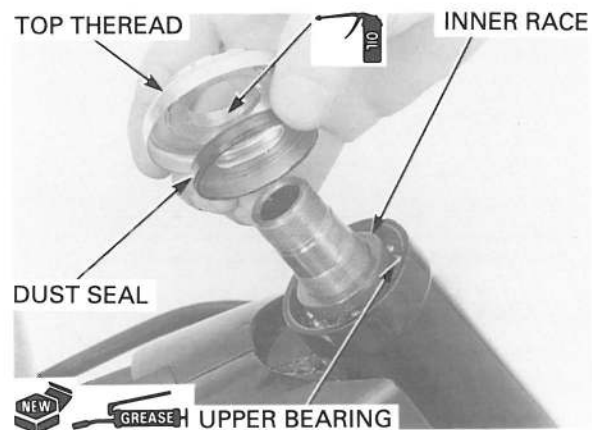

Tighten the top thread to the specified torque.

TOOL:

Steering stem socket 07916-3710101 or
07916-3710100

TORQUE: 21 N•m (2.1 kgf•m, 15 lbf•ft)

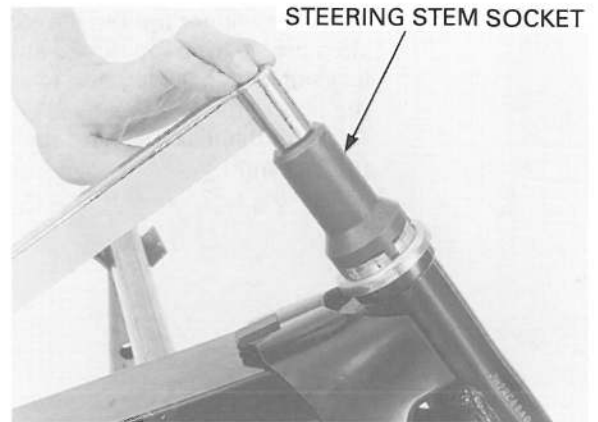

Turn the steering stem right and left, lock-to-lock at least five times to seat bearings. Make sure that the steering stem moves smoothly, without play or binding.

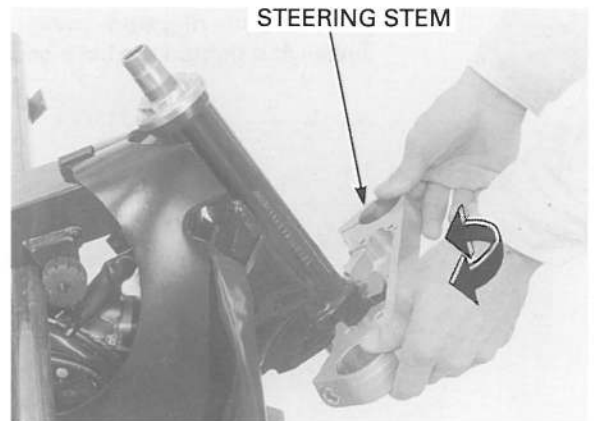

Retighten the top thread to the specified torque.

TOOL:

Steering stem socket 07916-3710101 or
07916-3710100

TORQUE: 21 N•m (2.1 kgf•m, 15 lbf•ft)



Install the new lock washer and bend the two opposite tabs down into the grooves in the top thread.

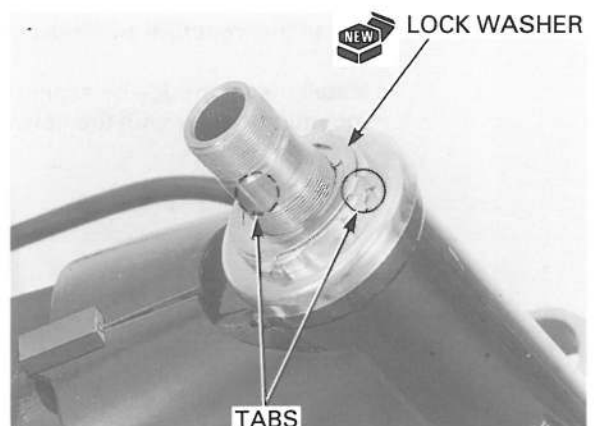

FRONT WHEEL/SUSPENSION/STEERING

Install and finger tighten the lock nut all the way. Hold the steering top thread and further tighten the lock nut, within 90 degrees, to align its grooves with the tabs of the lock washer. Bend up the lock washer tabs into the grooves of the lock nut.

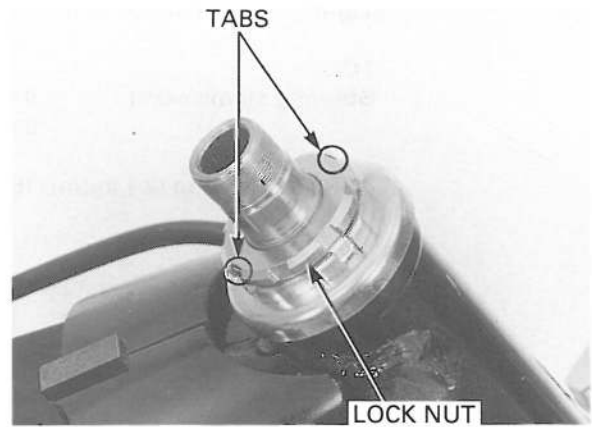

Install the steering stem cover to the steering stem. Install and tighten the bolts securely.

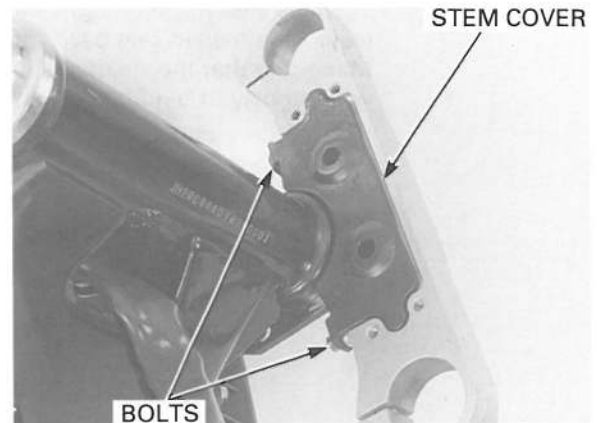

Install the headlight case and stay, aligning the headlight stay mounting rubber with the hole steering stem.

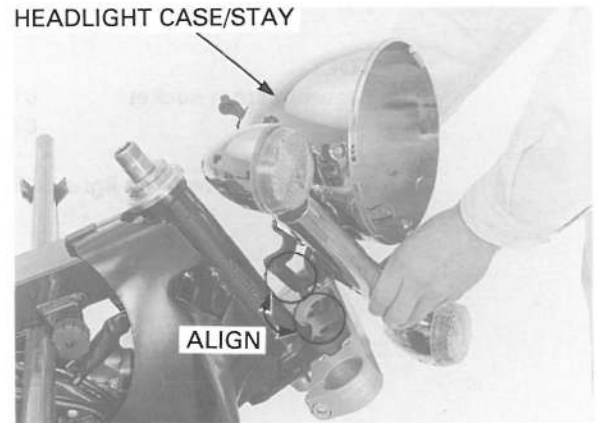

Install the front fork and fork covers (page 13-32).

Install the top bridge by aligning the headlight stay mounting rubber with the hole in the top bridge.

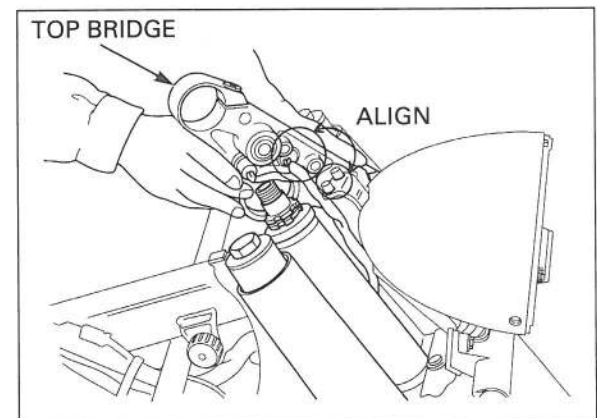

Install and tighten the steering stem nut to the specified torque.

TORQUE: 103 N·m (10.5 kgf·m, 76 lbf·ft)

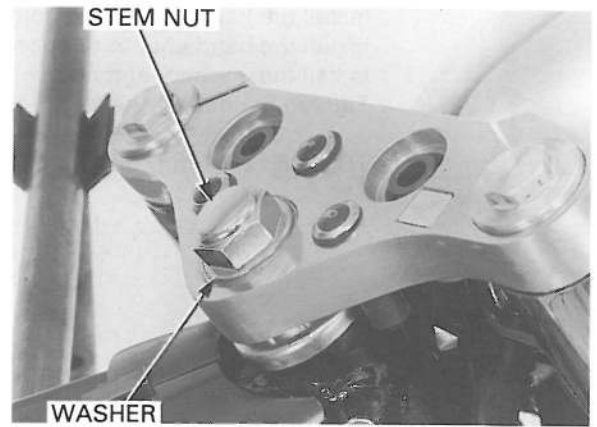

Connect the wire harness in the headlight case. Install the headlight (page 19-7).

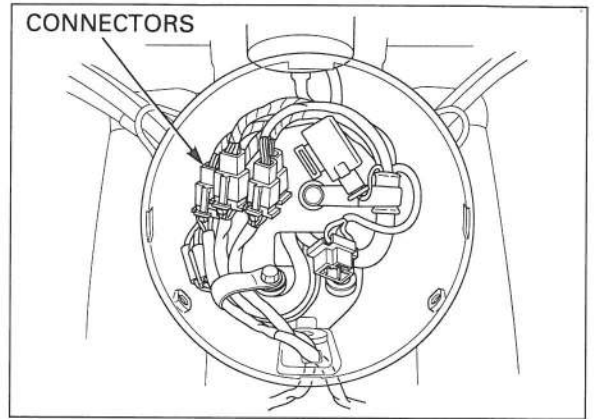

Install the brake hose guide and bolt. Tighten the bolt securely.

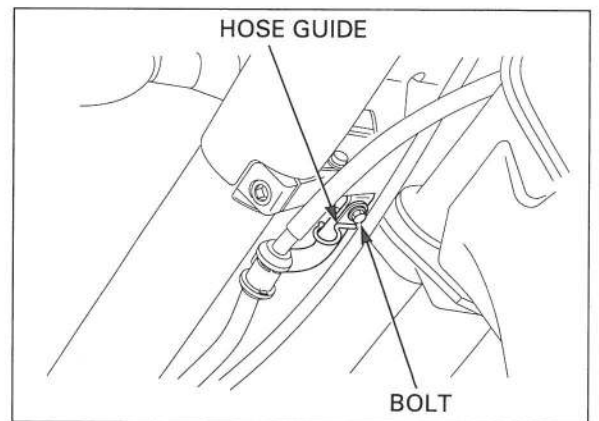

Check the bushings and replace if necessary. Install the bushings to the top bridge.

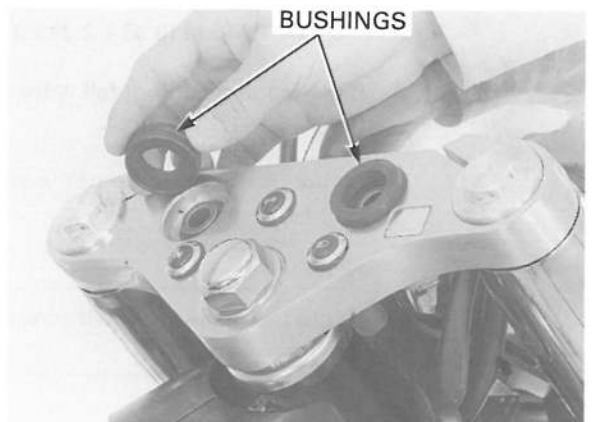

FRONT WHEEL/SUSPENSION/STEERING

Install the handlebar lower holders.
Install the handlebar to temporarily (page 13-9).
Install the washers and nuts.
Tighten the nuts to the specified torque.

TORQUE: 26 N·m (2.7 kgf·m, 20 lbf·ft)

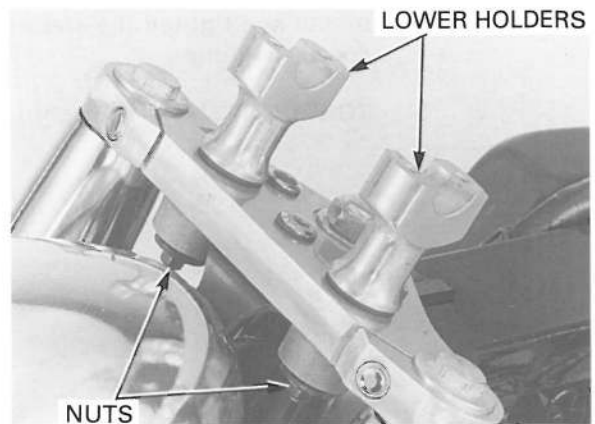

VT750C and VT750CD/CD2 (98-2000): Install the speedometer and stay to the top bridge.
Install and tighten the bolts
Connect the speedometer cable to the speedometer.

Install the following:
– Handlebar (page 13-9)
– Front wheel (page 13-20)

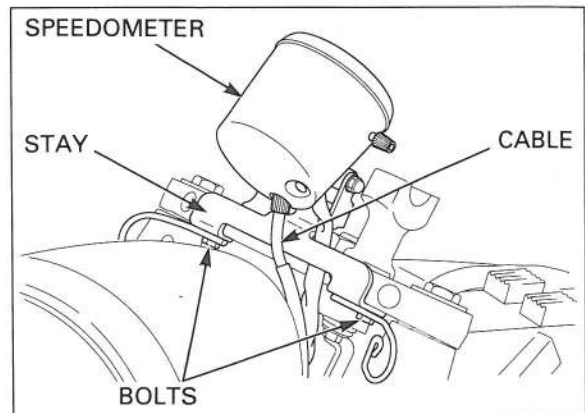

STEERING BEARING PRELOAD

Raise the front wheel off the ground.
Position the steering stem to the straight ahead position.
Hook a spring scale to the fork tube between the fork top and bottom bridges.
Make sure that there is no cable or wire harness interference.
Pull the spring scale keeping the scale at a right angle to the steering stem.

Read the scale at the point where the steering stem just starts to move.

STEERING BEARING PRELOAD:
0.43 – 1.04 kgf (0.95 – 2.30 lbf)

If the readings do not fall within the limits, readjust the steering top thread.

Install the removed parts in the reverse order of removal.

NOTE:

Route the cables and wire harness properly (page 1-22).

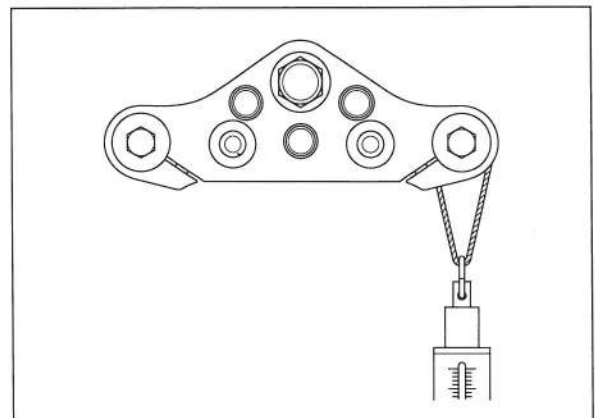

MEMO

REAR WHEEL/BRAKE/SUSPENSION

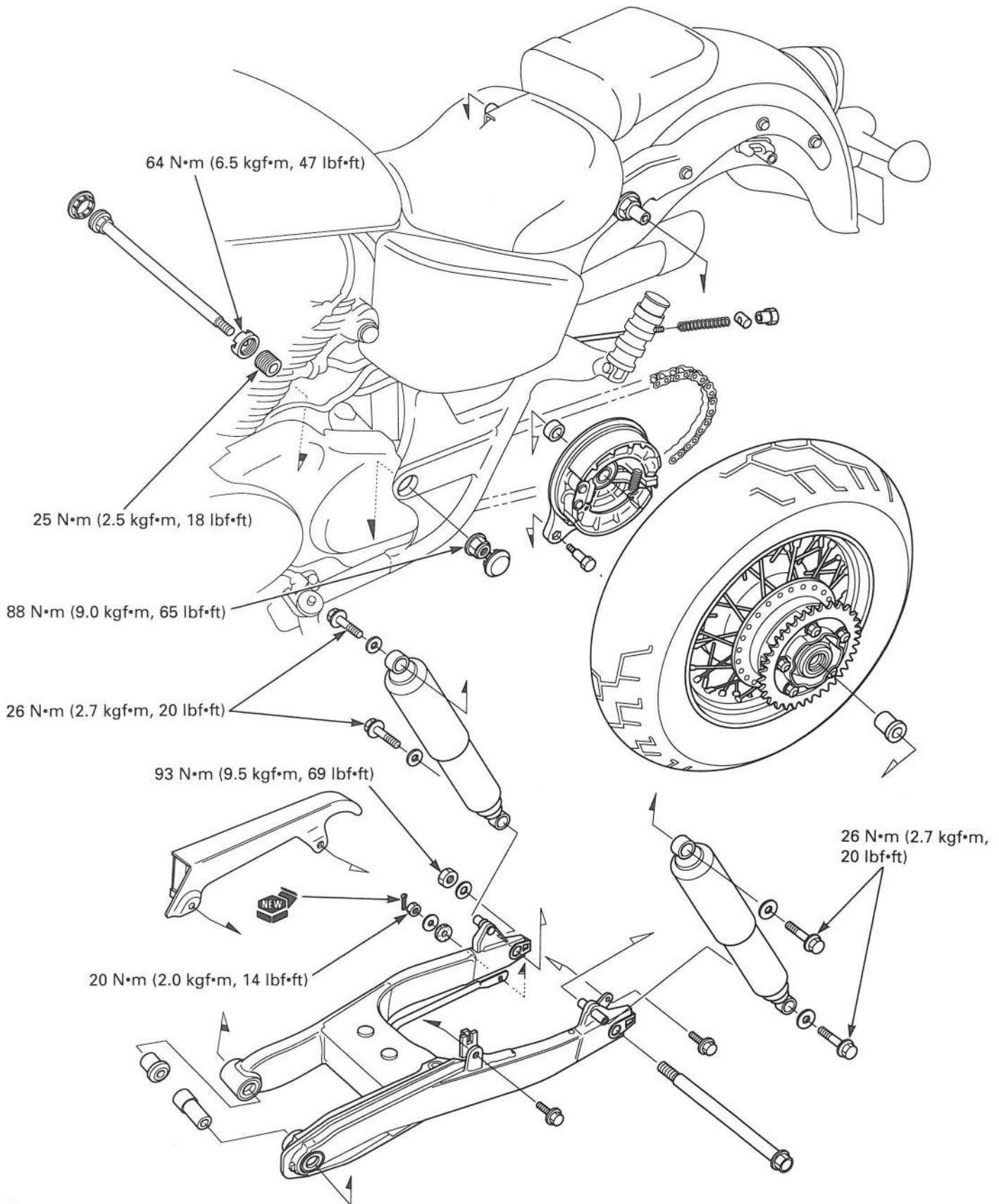

14. REAR WHEEL/BRAKE/SUSPENSION

SERVICE INFORMATION	14-1	BRAKE PEDAL	14-15
TROUBLESHOOTING	14-2	SHOCK ABSORBER	14-18
REAR WHEEL	14-3	SWINGARM	14-19
REAR BRAKE	14-11		

SERVICE INFORMATION

GENERAL

⚠ WARNING

- A contaminated brake drum or shoe reduces stopping power. Discard contaminated shoes and clean contaminated drum with a high quality brake degreasing agent.
- Riding on damaged rims or spokes impairs safe operation of the vehicle.
- Wheel balance directly affects the stability, handling and overall safety of the motorcycle. Carefully check balance before reinstalling the wheel.

CAUTION:

- To avoid damaging the rim when using the tire lever, always use rim protectors.
- Do not jack up the motorcycle using the oil filter.

- When servicing the rear wheel, swingarm or shock absorber, support the motorcycle using a safety stand or hoist.
- Use only genuine Honda replacement bolts and nuts for all suspension pivot and mounting points.

SPECIFICATIONS

Unit: mm (in)

ITEM		STANDARD	SERVICE LIMIT
Minimum tire thread depth		—	2.0 (0.08)
Cold tire pressure	Up to 90 kg (200 lb) load	200 kPa (2.00 kgf/cm ² , 29 psi)	—
	Up to maximum weight capacity	250 kPa (2.50 kgf/cm ² , 36 psi)	—
Axle runout		—	0.20 (0.008)
Wheel rim runout	Radial	—	2.0 (0.08)
	Axial	—	2.0 (0.08)
Wheel hub-to-rim distance		(page 14-8)	—
Wheel balance weight		—	70 g (2.5 oz)
Drive chain slack		15 – 25 (3/5 – 1)	40 (1-3/5)
Drive chain link		122 L	—
Drive chain size	DID	525 V8	—
	RK	525 SM5	—
Rear brake	Drum I. D.	180.0 – 180.3 (7.09 – 7.10)	181 (7.13)
	Lining thickness	5 (0.2)	2 (0.1)
Brake pedal height		50 mm (2.0 in) above the top of the footpeg	—
Brake pedal free play		20 – 30 (3/4 – 1-1/4)	—
Shock absorber spring preload adjuster setting		2nd position	—

REAR WHEEL/BRAKE/SUSPENSION

TORQUE VALUES

Rear axle nut	93 N•m (9.5 kgf•m, 69 lbf•ft)	U-nut
Driven sprocket nut	88 N•m (9.0 kgf•m, 65 lbf•ft)	U-nut
Rear shock absorber mounting bolt	26 N•m (2.7 kgf•m, 20 lbf•ft)	
Swingarm pivot nut	88 N•m (9.0 kgf•m, 65 lbf•ft)	
Swingarm pivot adjusting bolt	25 N•m (2.5 kgf•m, 18 lbf•ft)	
Swingarm pivot lock nut	64 N•m (6.5 kgf•m, 47 lbf•ft)	
Drive chain slider screw	3 N•m (0.3 kgf•m, 2.2 lbf•ft)	
Brake pedal pivot bolt	34 N•m (3.5 kgf•m, 25 lbf•ft)	
Rear brake stopper arm bolt	20 N•m (2.0 kgf•m, 14 lbf•ft)	
Rear brake arm bolt	29 N•m (3.0 kgf•m, 22 lbf•ft)	
Rear brake middle rod joint bolt	34 N•m (3.5 kgf•m, 25 lbf•ft)	
Spoke nipple	4 N•m (0.4 kgf•m, 2.9 lbf•ft)	

TOOLS

Attachment, 32 X 35 mm	07746-0010100	
Attachment, 42 X 47 mm	07746-0010300	
Pilot, 15 mm	07746-0040300	
Pilot, 20 mm	07746-0040500	
Pilot, 22 mm	07746-0041000	
Bearing remover shaft	07746-0050100	
Bearing remover head, 17 mm	07746-0050500	
Attachment, 28 X 30 mm	07746-1870100	
Driver	07749-0010000	
Snap ring priers	07914-3230001	
Driver shaft	07946-MJ00100	Not available in U.S.A.
Attachment	07946-MJ00200	Not available in U.S.A.
Driver shaft	07949-3710001	
Swingarm pivot lock nut wrench	07GMA-KT70200	Not available in U.S.A.
Spoke wrench	07JMA-MR60100	or equivalent commercially available in U.S.A.

TROUBLESHOOTING

Rear wheel wobbles

- Bent rim
- Worn rear wheel bearings
- Loose or bent spokes
- Faulty tire
- Unbalanced tire or wheel
- Low tire pressure
- Axle not tightened properly
- Chain adjusters not adjusted equally
- Faulty swingarm pivot bearings and bushings
- Bent frame or swingarm

Wheel turns hard

- Faulty wheel bearings
- Bent rear axle
- Brake drag

Rear suspension noisy

- Faulty rear shock absorber
- Loose fasteners

Soft suspension

- Weak spring
- Improper shock absorber spring preload
- Oil and gas leakage from damper unit
- Low tire pressure

Hard suspension

- Improper shock absorber spring preload
- Bent damper rod
- High tire pressure
- Damaged swingarm pivot bearings and bushings
- Bent frame or swingarm

Poor brake performance

- Improper brake adjustment
- Worn brake shoes
- Brake linings oily, greasy or dirty
- Worn brake cam
- Worn brake drum
- Brake arm serrations improperly engaged
- Brake shoes worn at cam contact area

REAR WHEEL

REMOVAL

CAUTION:

Do not jack up the motorcycle using the oil filter.

Raise and support the motorcycle using a hoist or jack.

Loosen the axle nut.

Loosen the drive chain adjusters on both sides of the swingarm.

Disconnect the brake rod from the brake arm.

Remove the cotter pin, nut, washers and bolt from the stopper arm on the brake panel.

Remove the axle nut, right side collar and rear axle.

Slide the rear wheel forward and remove the drive chain from the driven sprocket.

Remove the rear wheel.

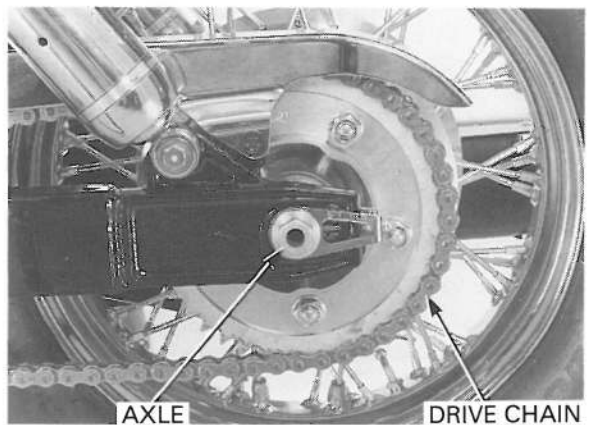
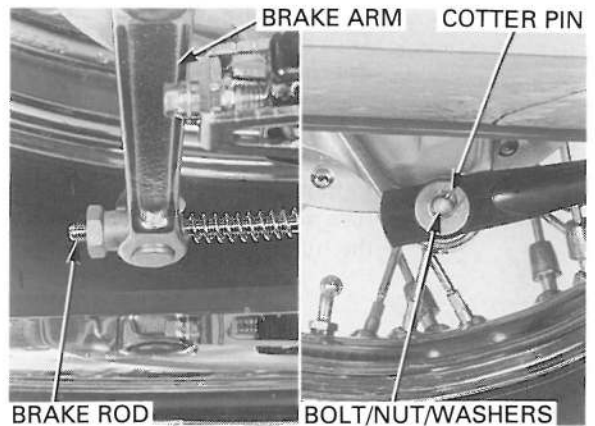
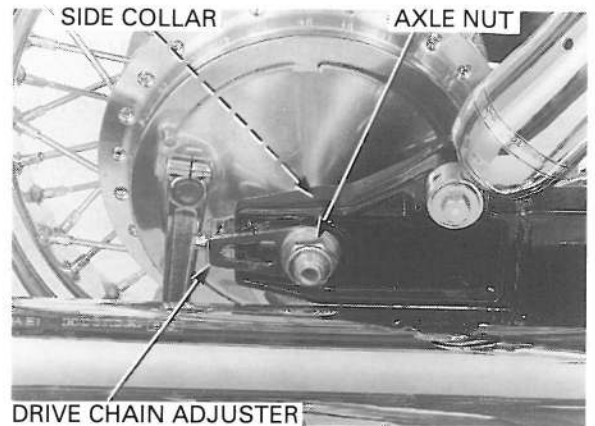

INSPECTION

AXLE

Place the axle in V-blocks and measure the runout. Actual runout is 1/2 the total indicator reading.

SERVICE LIMIT: 0.20 mm (0.008 in)

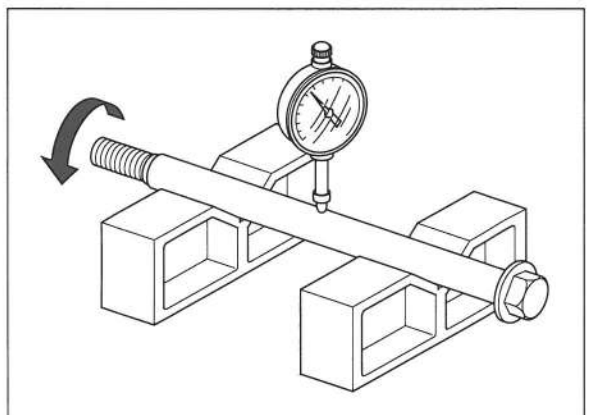

REAR WHEEL/BRAKE/SUSPENSION

WHEEL

Check the rim runout by placing the wheel in a turning stand.

Spin the wheel slowly and read the runout using a dial indicator.

Actual runout is 1/2 the total indicator reading.

SERVICE LIMITS: Radial: 2.0 mm (0.08 in)

Axial: 2.0 mm (0.08 in)

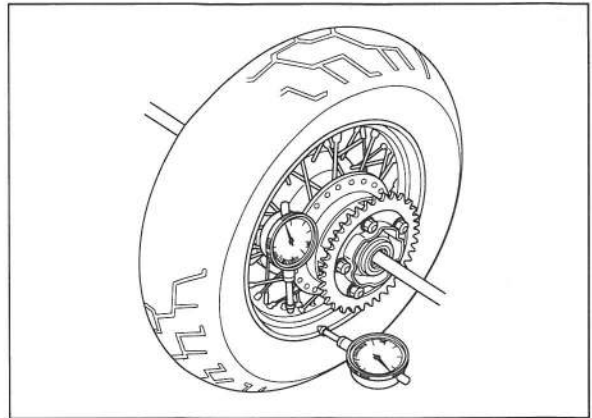

WHEEL BEARING

Turn the inner race of each bearing with your finger. Bearings should turn smoothly and quietly. Also check that the bearing outer race fits tightly in the hub.

Replace the wheel bearings in pairs.

Remove and discard the bearings if the races do not turn smoothly and quietly, or if they fit loosely in the hub.

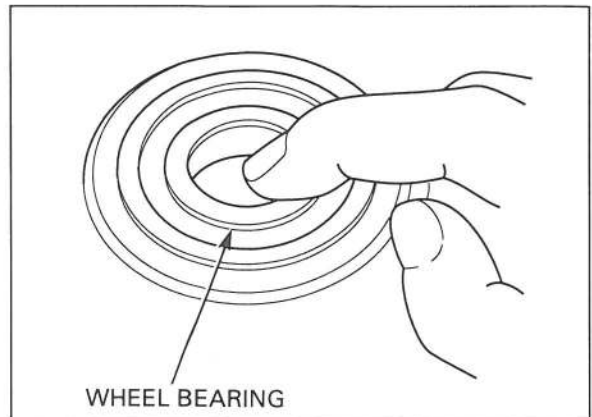

DRIVEN SPROCKET

Check the condition of the final driven sprocket teeth. Replace the sprocket if worn or damaged.

NOTE:

- If the final driven sprocket requires replacement, inspect the drive chain and drive sprocket.
- Never install a new drive chain on a worn sprocket or a worn chain on new sprockets. Both chain and sprocket must be in good condition or the replacement chain or sprocket will wear rapidly.

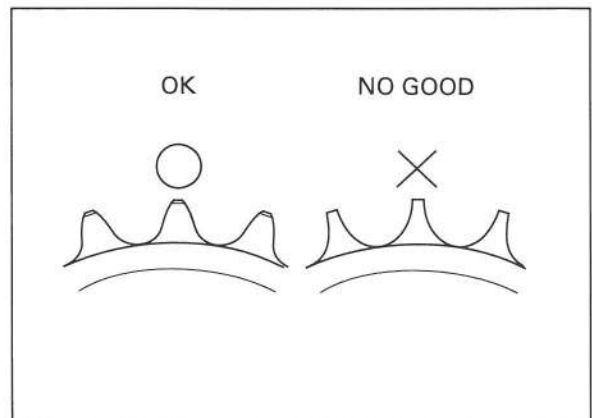

DISASSEMBLY

Remove the brake panel assembly from the right wheel hub.

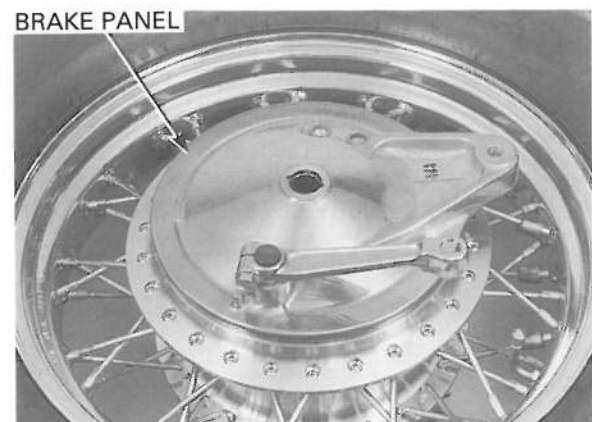

Remove the collar.

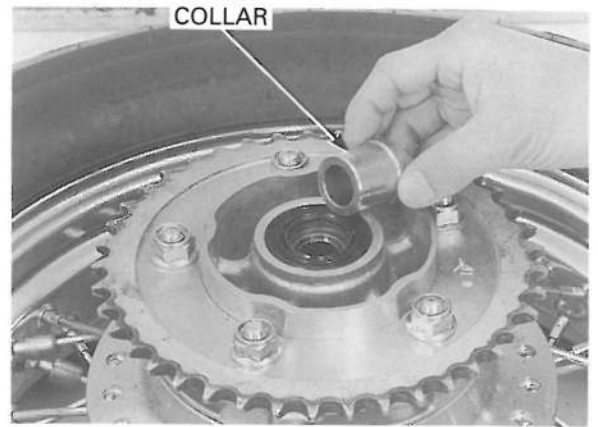

Remove the driven flange from the left wheel hub.

NOTE:

If you will be disassemble the driven flange, loosen the driven sprocket nuts before removing the driven flange from the wheel hub.

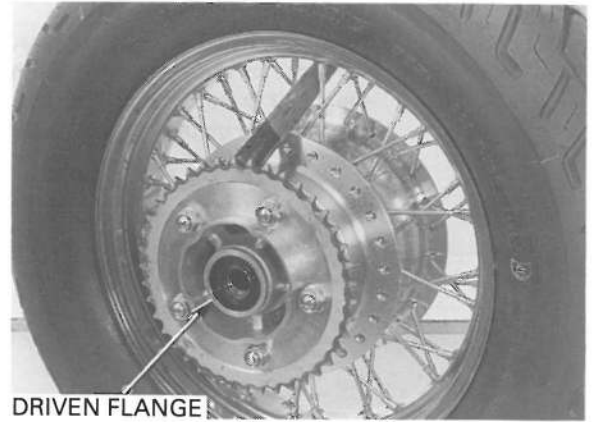

DRIVEN FLANGE

Remove the damper rubbers and O-ring.



DAMPER RUBBERS

O-RING

DRIVEN FLANGE BEARING REMOVAL

Remove the dust seal.

Remove the driven sprocket nuts and driven sprocket.

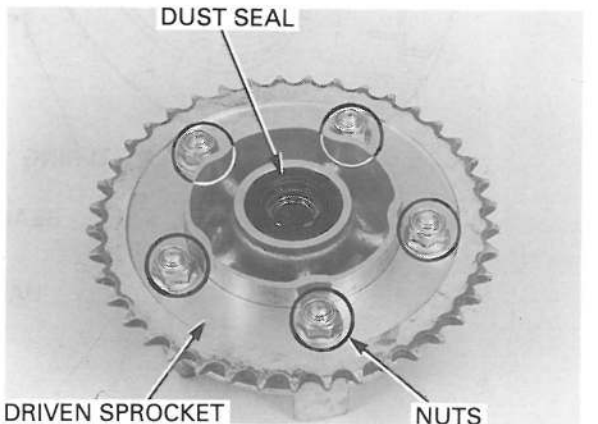

DUST SEAL

DRIVEN SPROCKET

NUTS

REAR WHEEL/BRAKE/SUSPENSION

Remove the driven flange bearing and collar.

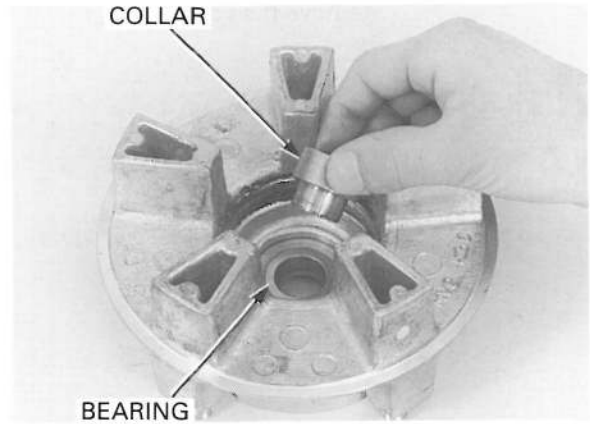

WHEEL BEARING REMOVAL

Install the bearing remover head into the bearing. From the opposite side install the bearing remover shaft and drive the bearing out of the wheel hub. Remove the distance collar and drive out the other bearing.

TOOLS:

Bearing remover shaft 07746-0050100
Bearing remover head, 17 mm 07746-0050500

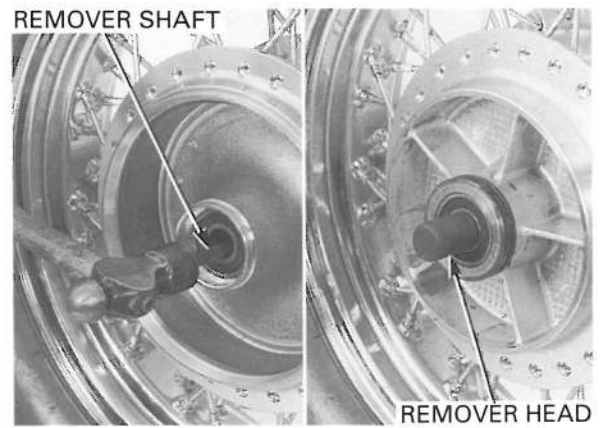

ASSEMBLY

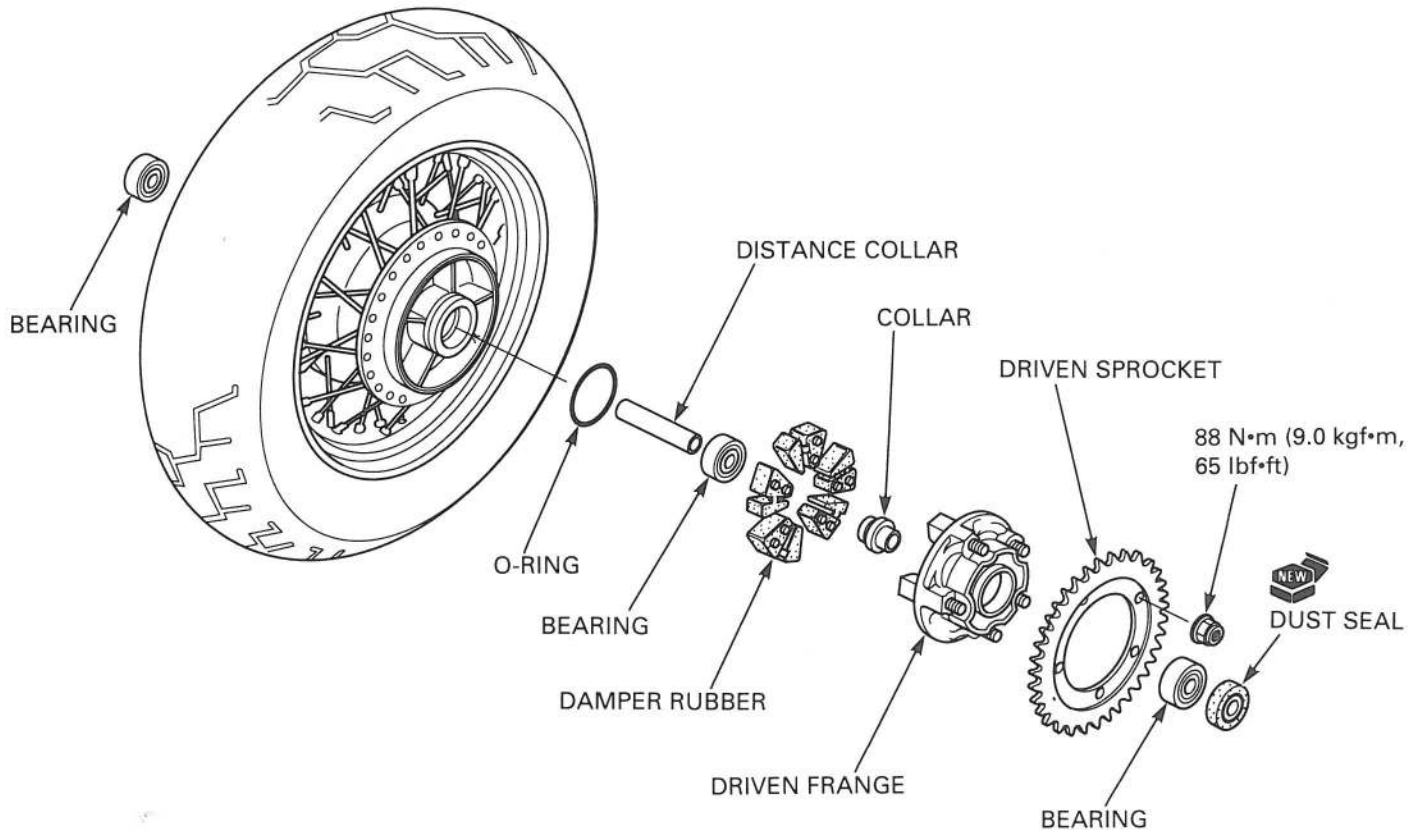

WHEEL BEARING INSTALLATION

Pack all bearing cavities with grease.

CAUTION:

Never install an old bearing has been removed, the bearing must be replaced with a new one.

Drive a new left bearing squarely with its sealed side facing out.

Install the distance collar, then drive in the right side bearing with its sealed side facing out.

TOOLS:

Driver	07749-0010000
Attachment, 42 X 47 mm	07746-0010300
Pilot, 20 mm	07746-0040500

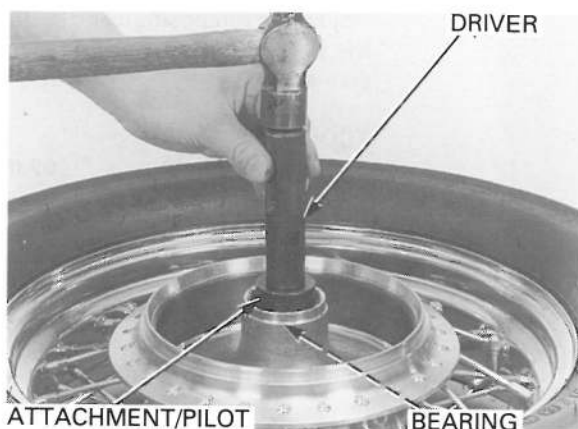
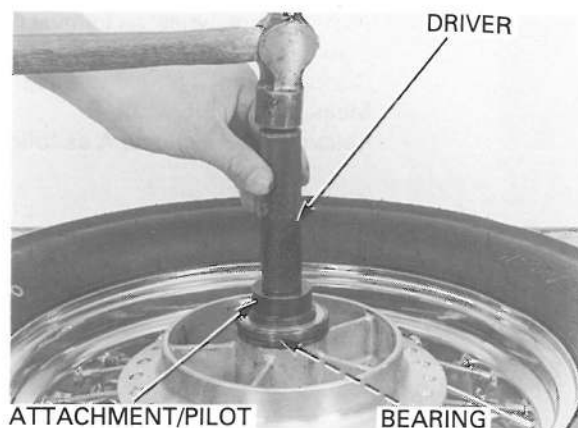

DRIVEN FLANGE BEARING INSTALLATION

Install the driven flange collar to the new driven flange bearing using the special tools.

TOOLS:

Driver	07749-0010000
Attachment, 32 X 35 mm	07746-0010100
Pilot, 20 mm	07746-0040500

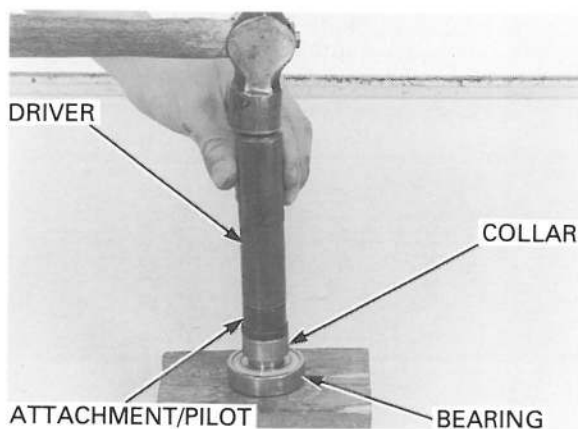

Drive the driven flange bearing and collar into the driven flange using the special tools.

TOOLS:

Driver	07749-0010000
Attachment, 42 X 47 mm	07746-0010300
Pilot, 20 mm	07746-0040500

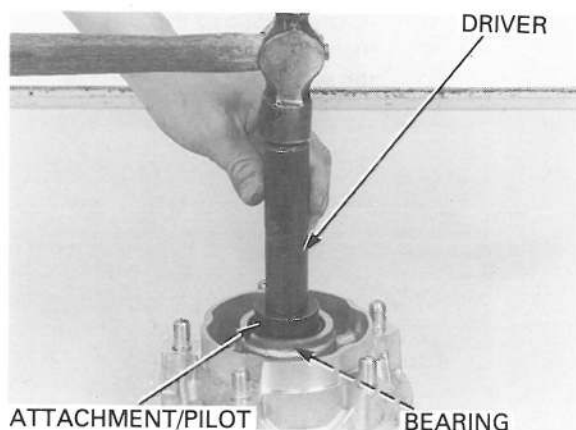

REAR WHEEL/BRAKE/SUSPENSION

Assemble the wheel as follows if wheel is disassembled.

Clean the spoke nipple threads.

Measure the hub width B.

Calculate the distance A as following:

$$A = 72.7 \text{ mm} - B/2$$

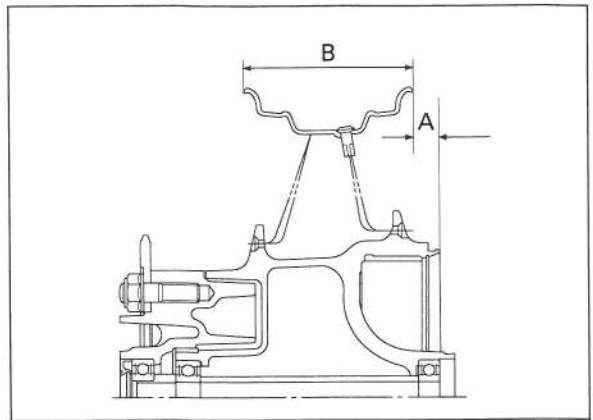

Adjust the rim position and distance A by tightening the spokes to the specified torque in 2 or 3 progressive steps.

TOOL:

Spoke wrench

**07JMA-MR60100
or equivalent
commercially available
in U.S.A.**

TORQUE: 4 N·m (0.38 kgf·m, 2.7 lbf·ft)

Check the rim runout (page 14-4).

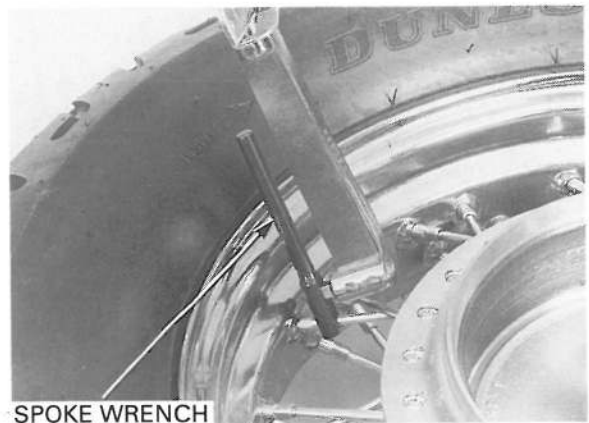

SPOKE WRENCH

Apply grease to the new dust seal lips, then install it into the driven flange.

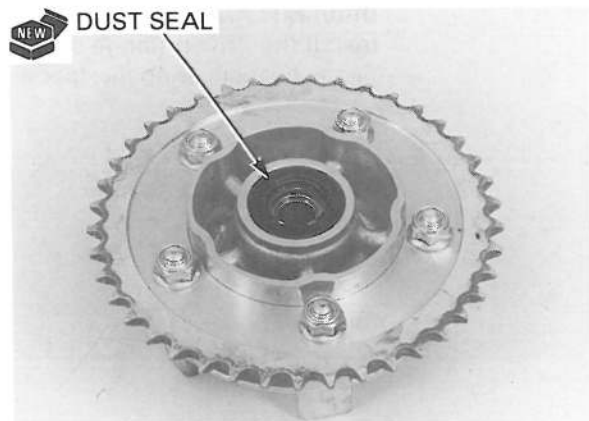

DUST SEAL

Apply grease to the O-ring.

Install the wheel damper rubbers and O-ring into the wheel hub.

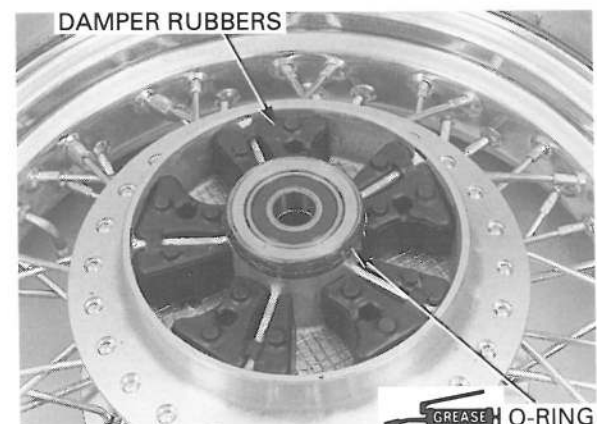

DAMPER RUBBERS

GREASE O-RING

⚠ WARNING

Do not get grease on the brake drum or stopping power will be reduced.

Install the driven flange assembly into the left wheel hub.
Apply grease to the new dust seal lips, then install it into the driven flange.

If the driven sprocket was removed, clean and apply a locking agent to the driven flange stud bolt threads. Install the driven sprocket and tighten the nuts.

TORQUE: 88 N·m (9.0 kgf·m, 65 lbf·ft)

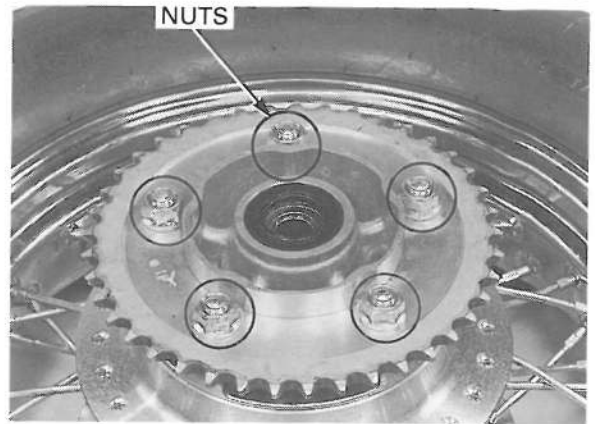

WHEEL BALANCE

⚠ WARNING

Wheel balance directly affects the stability, handling and overall safety of the motorcycle. Carefully check balance before reinstalling the wheel.

NOTE:

- The wheel balance must be checked when the tire is remounted.
- For optimum balance, the tire balance mark (a paint dot on the side wall) must be located next to the valve stem. Remount the tire if necessary.

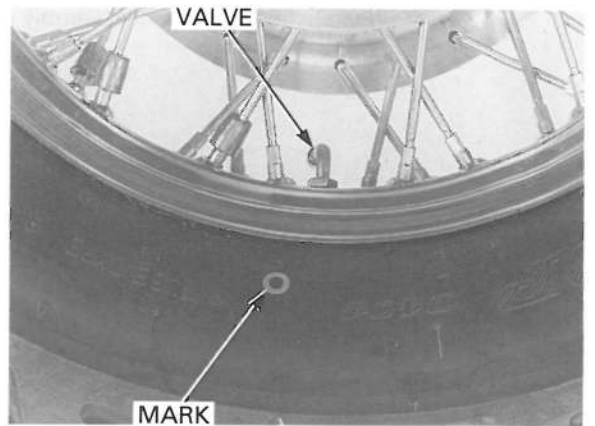

Mount the wheel, tire and driven flange assembly on an inspection stand.
Spin the wheel, allow it to stop, and mark the lowest (heaviest) part of the wheel with chalk.
Do this two or three times to verify the heaviest area.
If the wheel is balanced, it will not stop consistently in the same position.

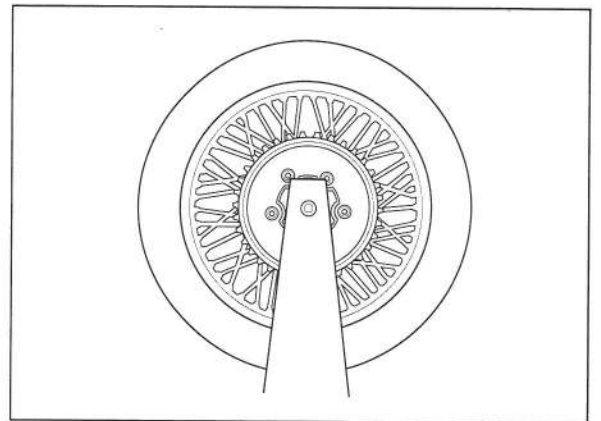

To balance the wheel, install balance weights on the lightest side of rim, the side opposite the chalk marks.
Add just enough weight so the wheel will no longer stop in the same position when it is spun.
Do not add more than 70 g (2.5 oz) to the front wheel.



REAR WHEEL/BRAKE/SUSPENSION

Install the left side collar.

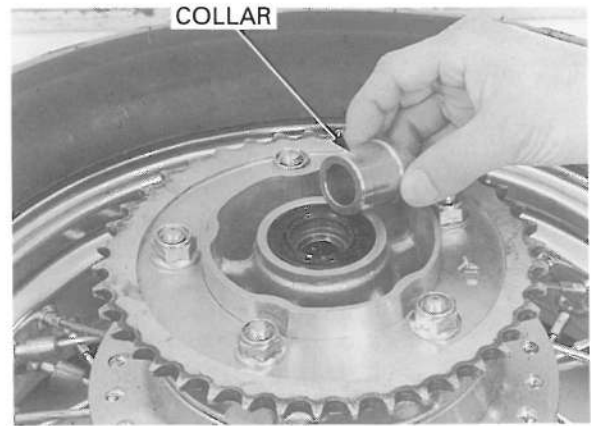

Install the brake panel assembly into the right wheel hub.

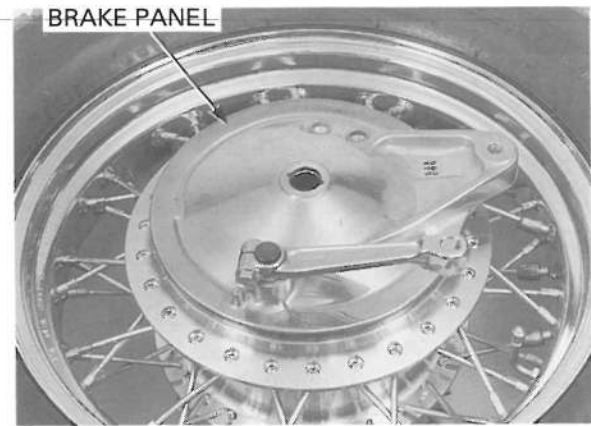

INSTALLATION

Position the rear wheel between in swingarm.

Insert the axle (from the left side) through the swingarm, wheel hub and side collars.

Install the drive chain over the driven sprocket.

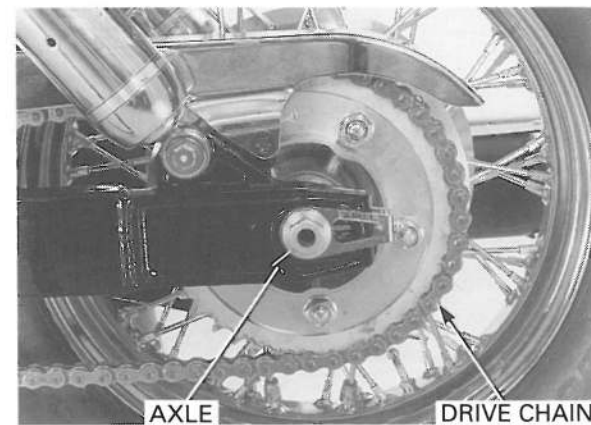

Install the axle nut.

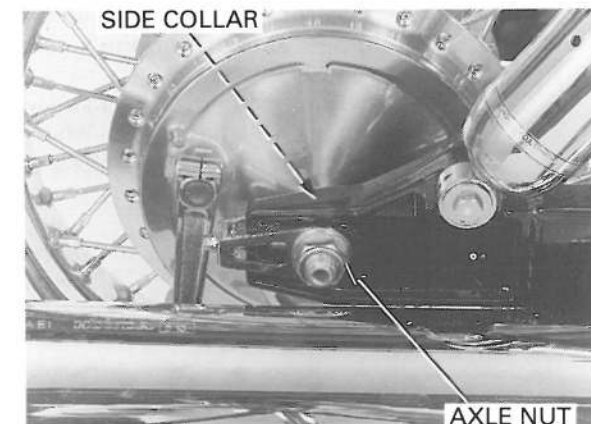

Connect the brake stopper arm to the brake panel with bolt, seat washer, washer and nut. Tighten the nut to the specified torque.

TORQUE: 20 N·m (2.0 kgf·m, 14 lbf·ft)

Install the new cotter pin and bend back it securely. Connect the brake rod to the brake arm.

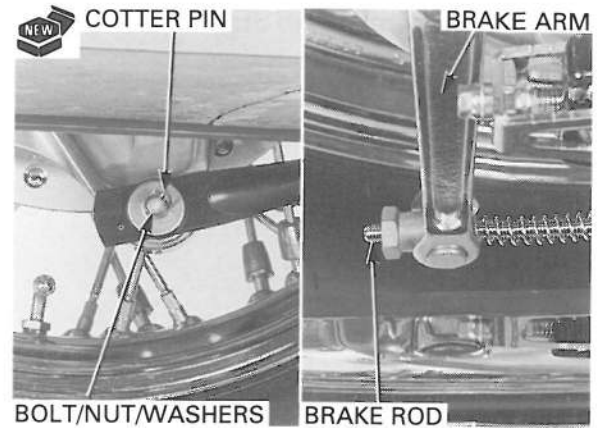

Adjust the drive chain (page 3-18) and rear brake pedal free play (page 3-24).

Tighten the axle nut.

TORQUE: 93 N·m (9.5 kgf·m, 69 lbf·ft)

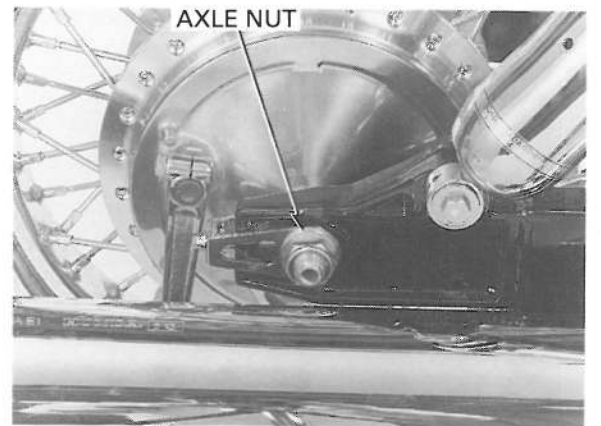

REAR BRAKE

REMOVAL

Remove the rear wheel (page 14-3).
Remove the brake panel from the rear wheel (page 14-4).

INSPECTION

Measure the brake drum I.D.

SERVICE LIMIT: 181 mm (7.13 in)

Measure the brake lining thickness.

SERVICE LIMIT: 2 mm (0.1 in)

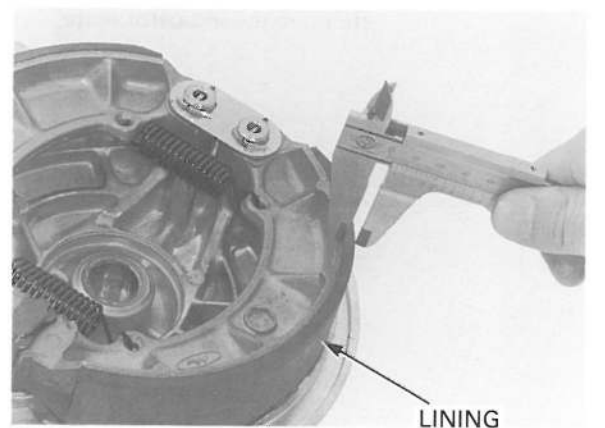
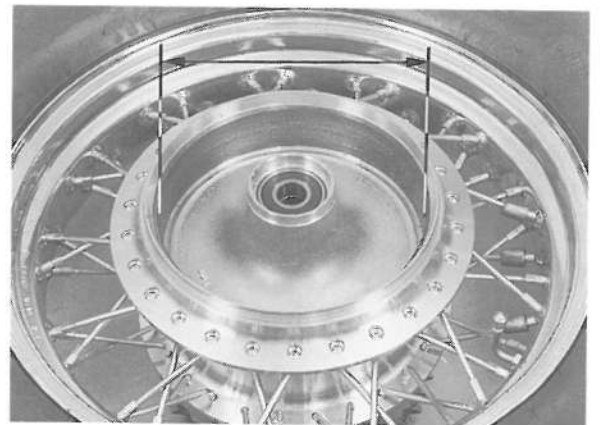

REAR WHEEL/BRAKE/SUSPENSION

DISASSEMBLY

Remove the cotter pins and set plate.

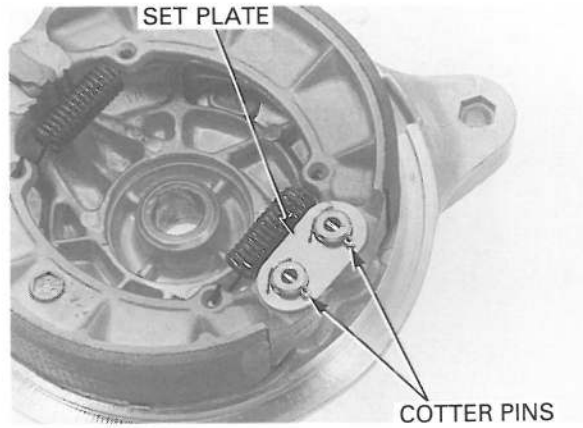

Mark the shoes to indicate their original positions before removing them. Remove the brake shoes and springs.

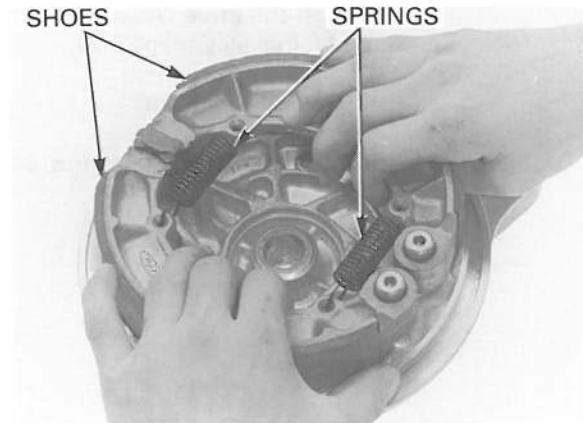

Remove the bolt and brake arm.

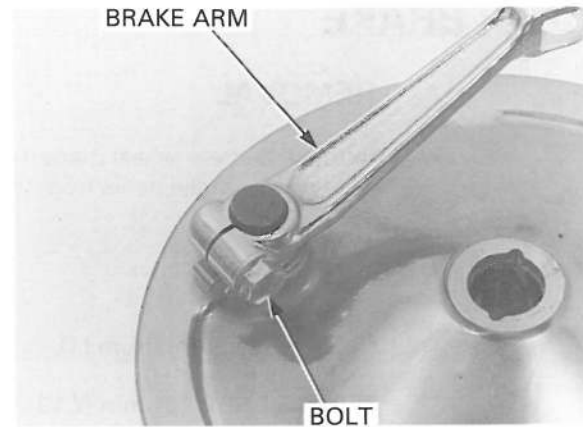

Remove the indicator plate.



Remove the brake cam.

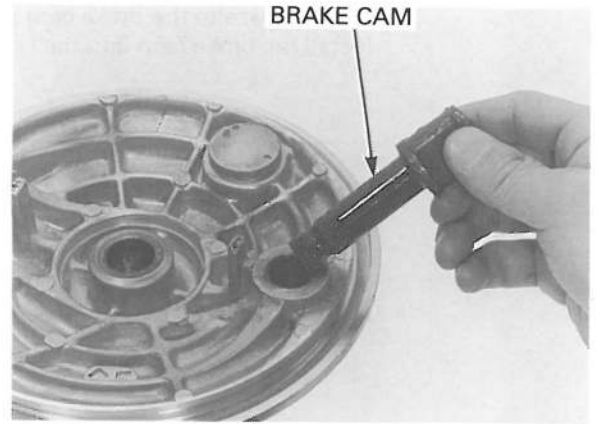

Remove the felt seal.

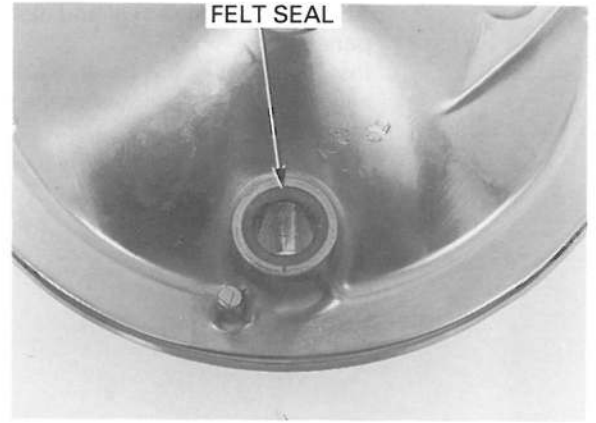

ASSEMBLY

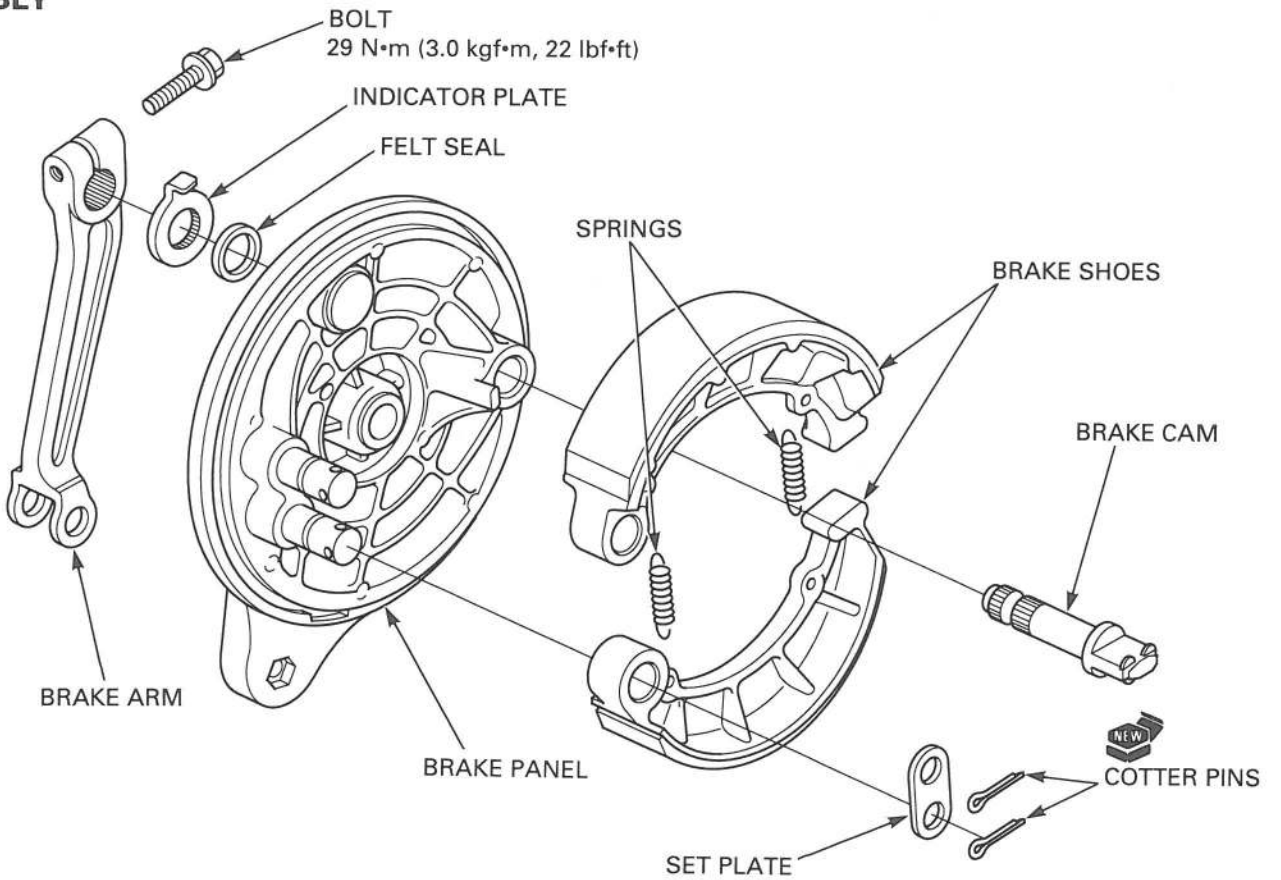

REAR WHEEL/BRAKE/SUSPENSION

Apply grease to the brake cam sliding surface.
Install the brake cam into the brake panel.

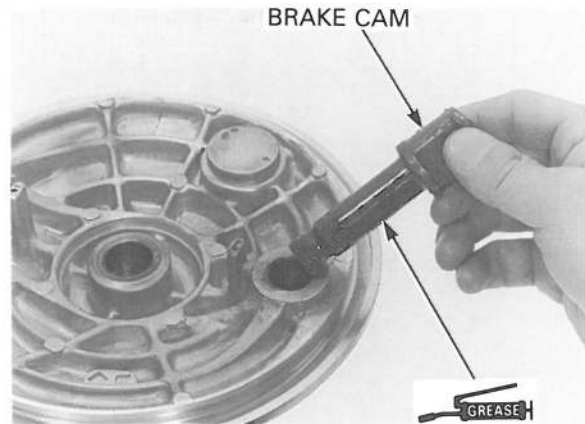

Apply oil to the felt seal and install it onto the brake panel.
Install the wear indicator plate on the brake cam aligning its wide tooth with the wide groove on the brake cam.

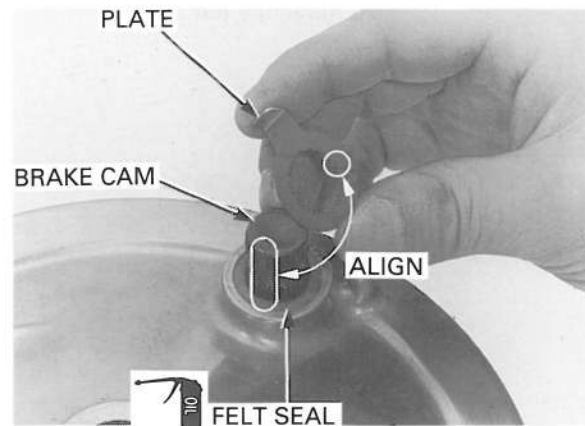

Install the brake arm aligning the punch marks of the arm and the brake cam.
Install and tighten the brake arm pinch bolt to the specified torque.

TORQUE: 29 N·m (3.0 kgf·m, 22 lbf·ft)

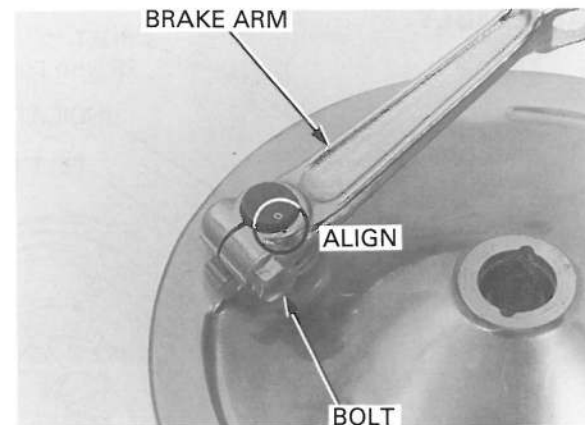

Apply grease to the brake shoe-to-cam sliding surface.
Apply grease to the anchor pin sliding surfaces.
Install the brake shoes and springs.

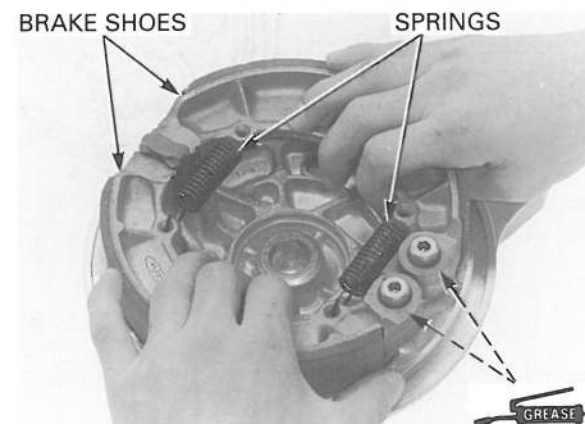

Install the set plate and new cotter pins.

INSTALLATION

Install the brake panel into the wheel hub (page 14-10).

Install the rear wheel (page 14-10).

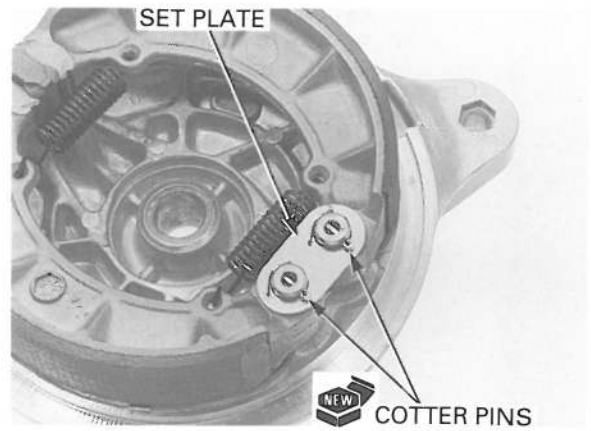

BRAKE PEDAL

REMOVAL

Remove the muffler (page 2-7).

Disconnect the brake rod from the brake arm.

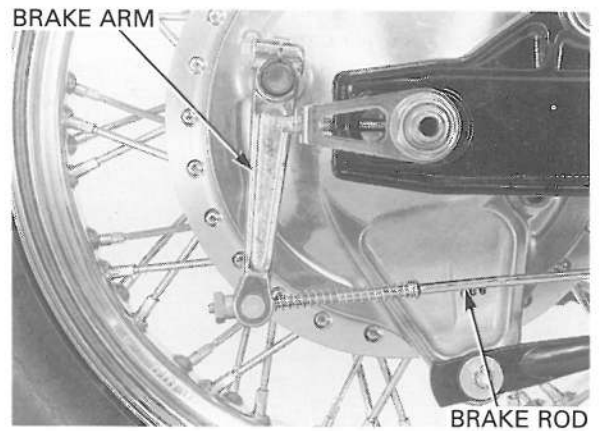

Remove the middle rod joint bolt and washer.
Unhook the middle rod joint return spring.

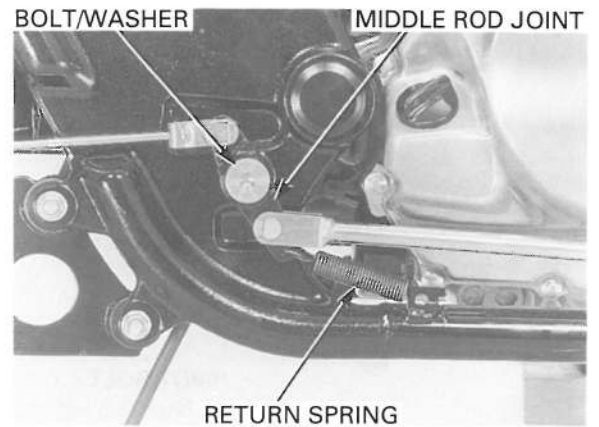

Remove the bolts and right footpeg holder assembly.

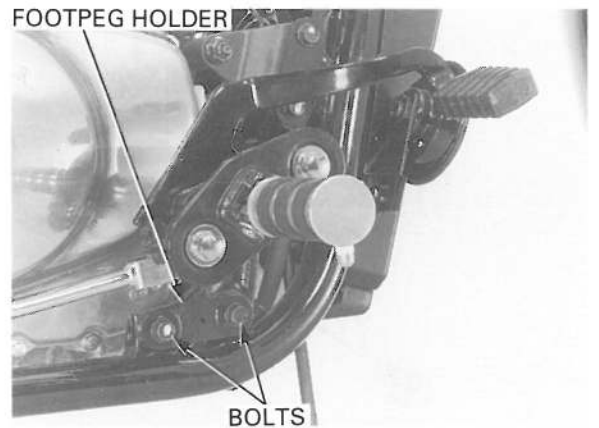

REAR WHEEL/BRAKE/SUSPENSION

Remove the brake pedal pivot bolt and washer, then remove the brake pedal.
Unhook the rear brake light switch spring from the brake rod.
Remove the brake rod assembly.

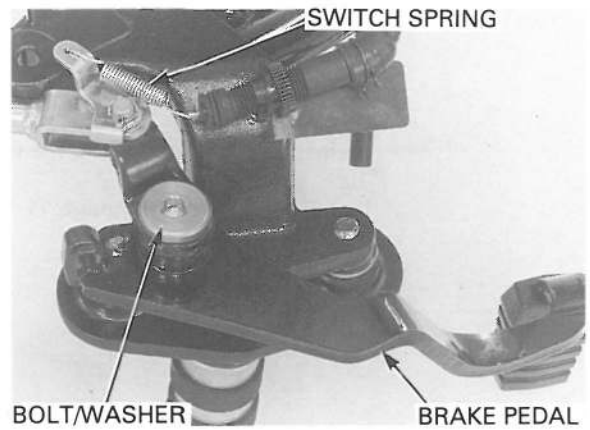

Inspect the brake pedal, rods and middle rod joint for damage.
Inspect the joint pin for wear or damage.
Replace these parts if necessary.

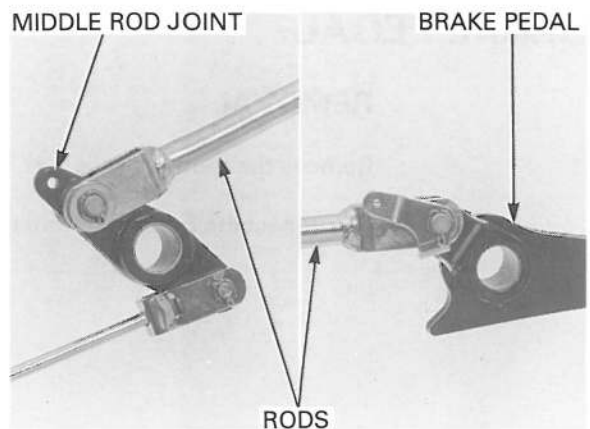

INSTALLATION

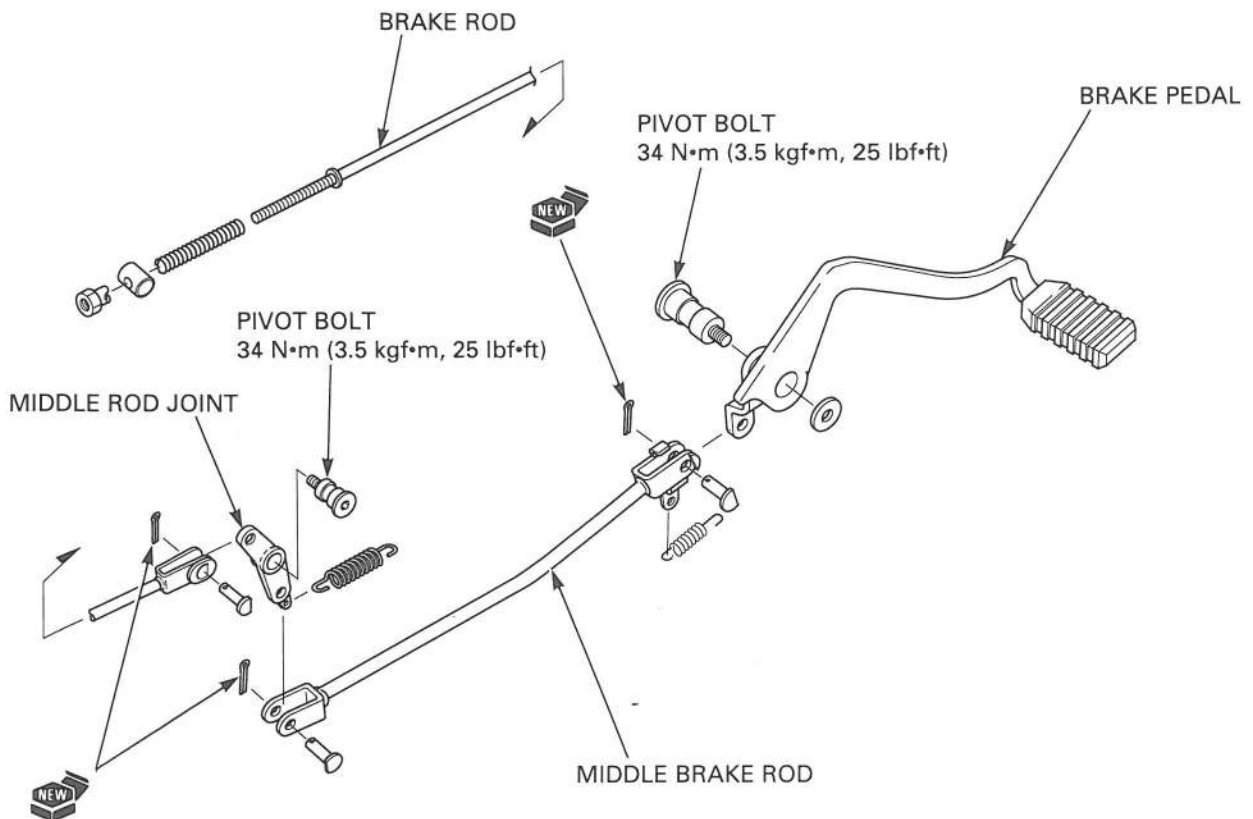

Hook the rear brake light switch spring as shown.

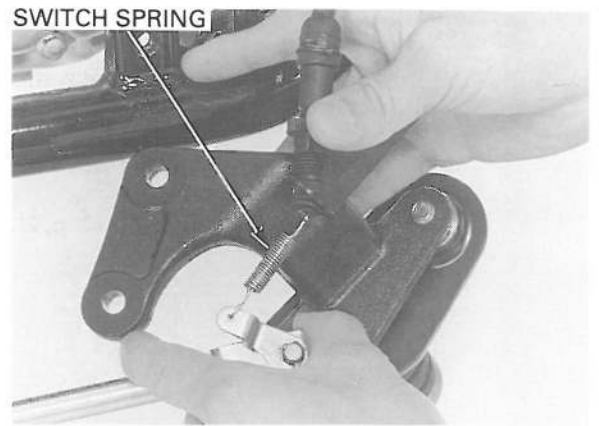

Apply grease to the brake pedal pivot bolt sliding area.

Install the brake pedal, washer and pivot bolt to the frame.

Tighten the bolt to the specified torque.

TORQUE: 34 N·m (3.5 kgf·m, 25 lbf·ft)

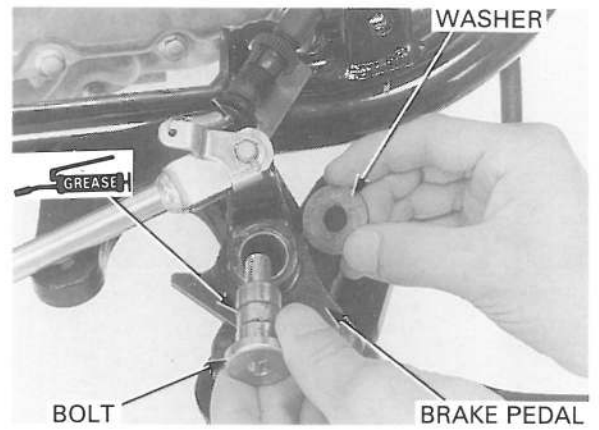

Install the right footpeg holder to the frame.
Install and tighten the mounting bolts securely.

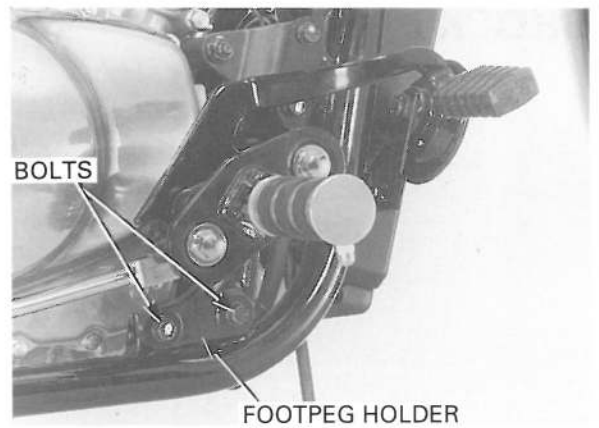

Hook the middle rod joint return spring as shown.

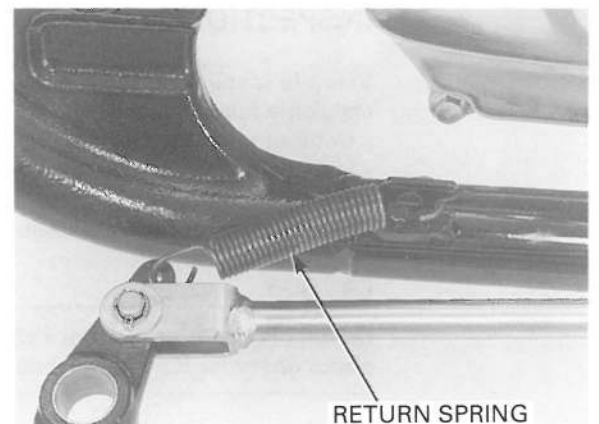

REAR WHEEL/BRAKE/SUSPENSION

Apply grease to the middle rod joint bolt sliding area.

Install the middle rod joint with the washer and joint bolt.

Tighten the bolt to the specified torque.

TORQUE: 34 N·m (3.5 kgf·m, 25 lbf·ft)

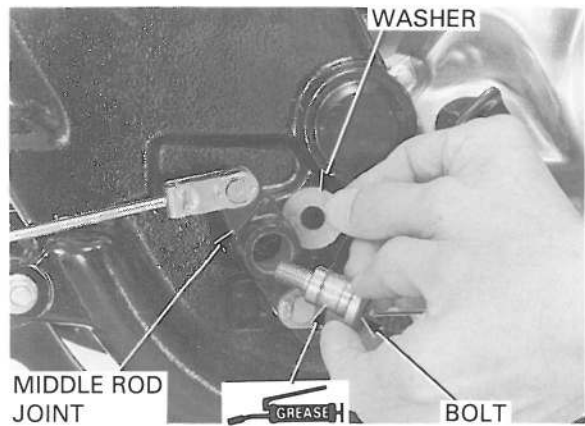

Connect the brake rod to the brake arm.

Install the muffler (page 2-8).

Adjust the brake pedal free play (page 3-24).

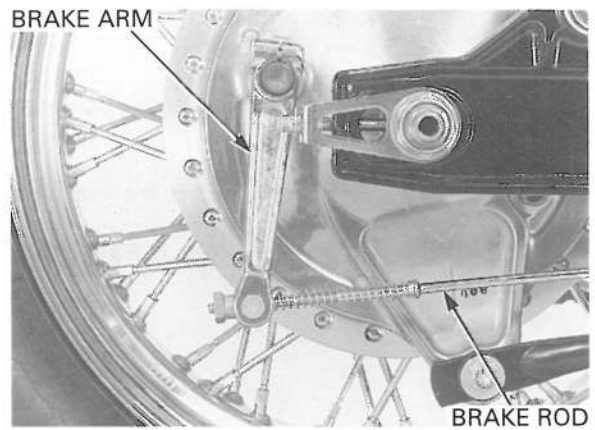

SHOCK ABSORBER

REMOVAL

Raise and support the motorcycle using a hoist or jack under the engine.

Remove the upper and lower mounting bolts and washers.

Remove the shock absorber.

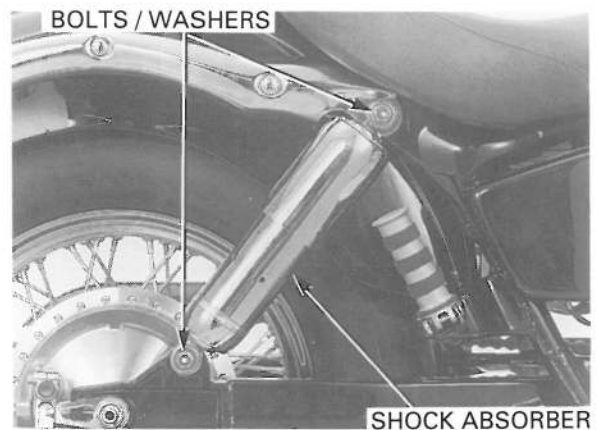

INSPECTION

Visually inspect the shock absorber for damage. check the following:

- Damper unit for deformation or oil leaks
- Upper and lower joint bushings for wear or damage

Check smooth damper operation.

CAUTION:

Do not disassemble the shock absorber. Replace the shock absorber if any component is damaged.



INSTALLATION

Install the shock absorber with the arrow mark facing forward and upward.



Install the mounting bolts and washers. Tighten the bolts to the specified torque.

TORQUE: 26 N·m (2.7 kgf·m, 20 lbf·ft)

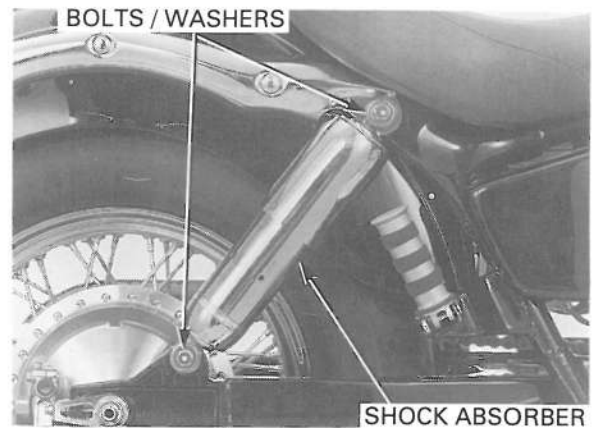

SWINGARM

REMOVAL

Remove the muffler (page 2-7).
Remove the rear wheel (page 14-3).
Remove the right and left shock absorbers (page 14-18).

Remove the bolts and drive chain cover.

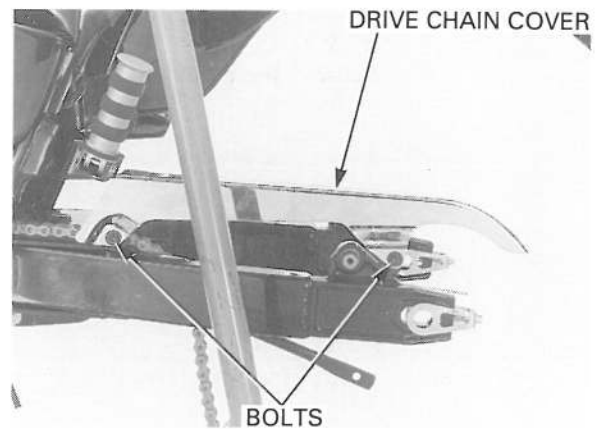

Remove the pivot bolt caps.

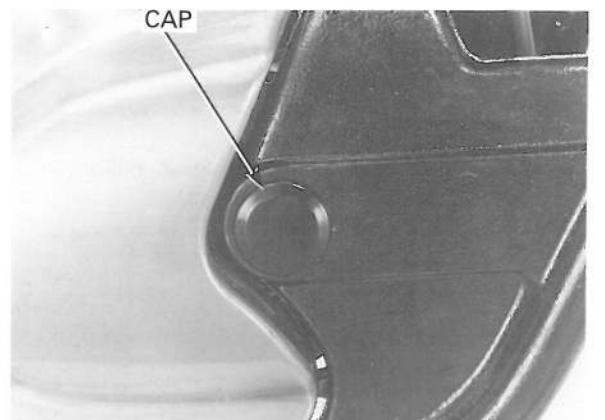

REAR WHEEL/BRAKE/SUSPENSION

Remove the swingarm pivot nut.

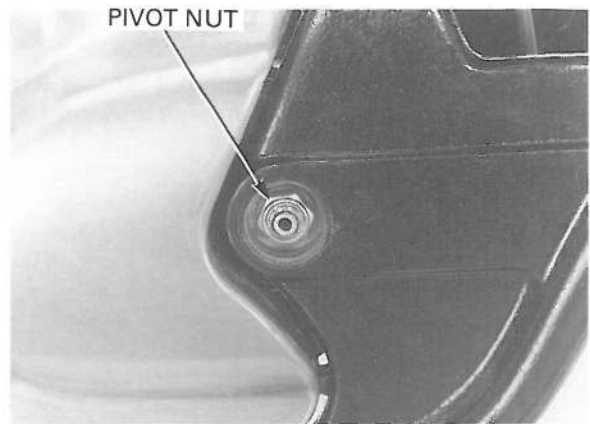

Remove the swingarm pivot lock nut while holding the pivot bolt.

TOOL:
Swingarm pivot lock nut wrench 07GMA-KT70200
Not available in U.S.A.

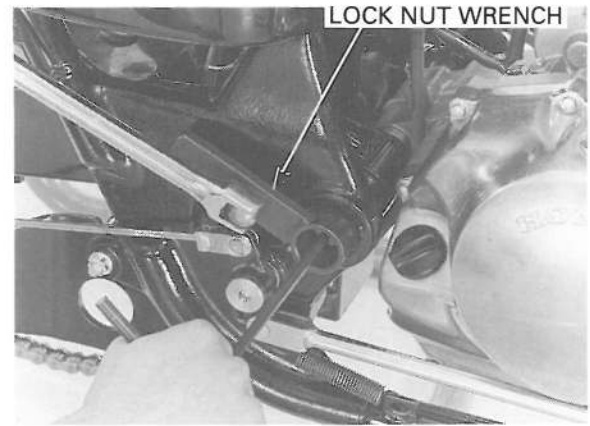

Loosen the swingarm adjusting bolt by turning the pivot bolt.
Remove the pivot bolt and swingarm.

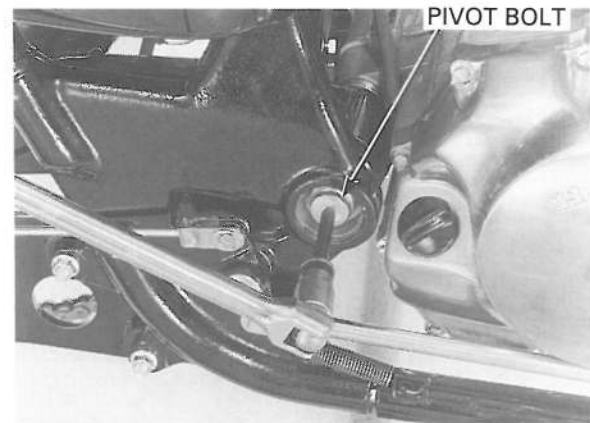

DISASSEMBLY

Inspect the drive chain slider for wear or damage.
Replace it if necessary.

Remove the screws, collars and drive chain slider.

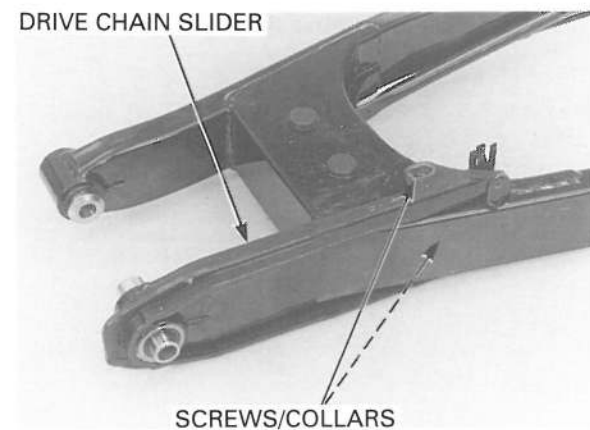

REAR WHEEL/BRAKE/SUSPENSION

Remove the cotter pin, nut, washers, bolt and stopper arm.

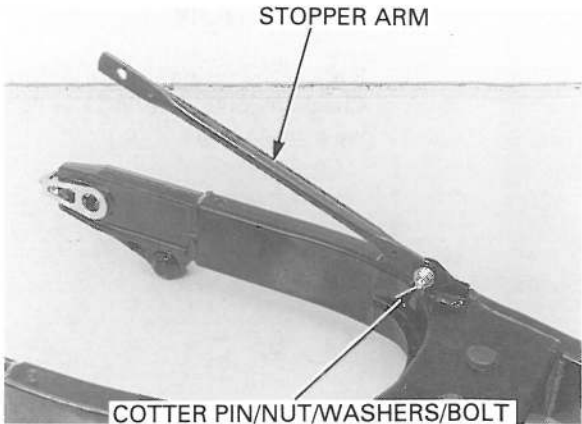

Remove the right and left drive chain adjusters.

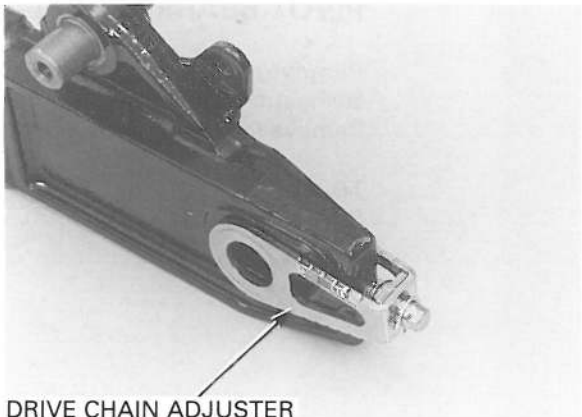

Remove the collar and dust seals from the left side pivot.

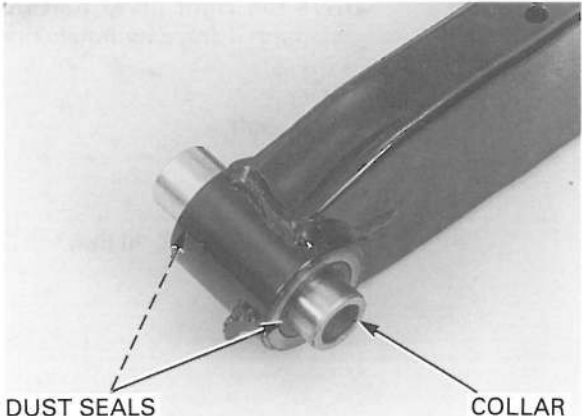

Remove the collars and dust seals from the right side pivot.

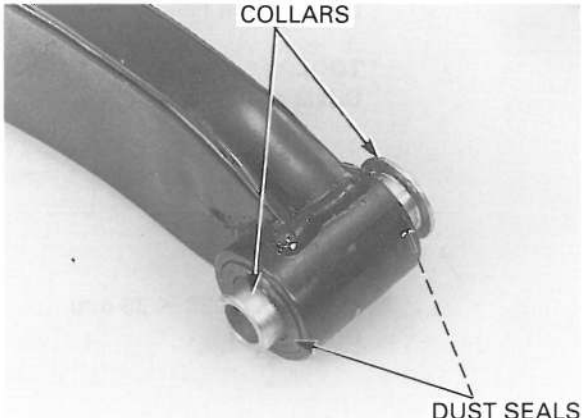

INSPECTION

Inspect the swingarm for deformation or cracks. Check the pivot bearings, collars and dust seals for wear or damage.

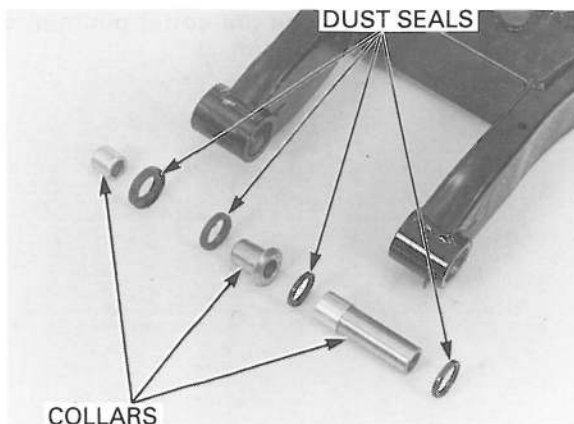

PIVOT BEARING REPLACEMENT

Remove the dust seals from the right and left swingarm pivots. Remove the snap ring from the right pivot.

TOOL:

Snap ring pliers 07914-3230001



Drive the right pivot ball bearings out of the swingarm using a hydraulic press and driver shaft.

TOOL:

Driver shaft 07946-MJ00100
Not available in
U.S.A. or
Pilot, 15 mm 07746-0040300
Attachment, 28 × 30 mm 07946-1870100
Driver shaft 07949-3710001

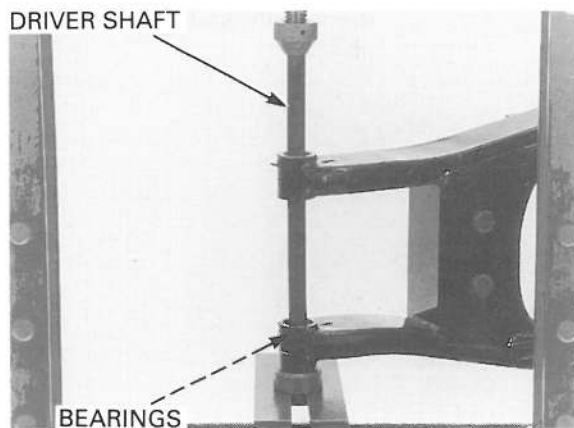

Drive the left needle bearing out of the swingarm.

TOOL:

Driver shaft 07946-MJ00100
Not available in
U.S.A.
Attachment 07946-MJ00200
Not available in
U.S.A. or
Pilot, 20 mm 07746-0040500
Attachment, 28 × 30 mm 07946-1870100
Driver shaft 07949-3710001

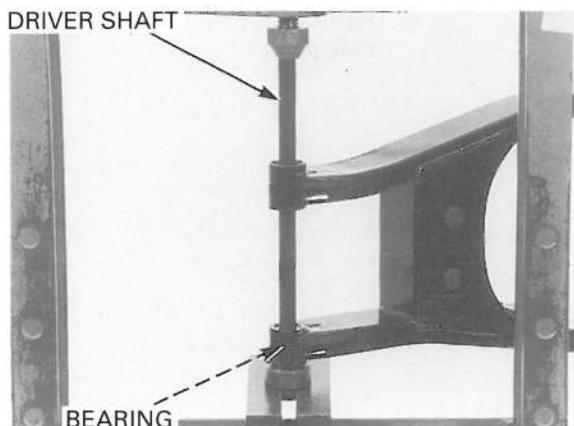

REAR WHEEL/BRAKE/SUSPENSION

Install the bearings with the mark facing out.

Apply grease to the new right side ball bearings. Press the new right side ball bearings into the swingarm.

TOOLS:

Driver	07749-0010000
Attachment, 32 X 35 mm	07746-0010100
Pilot, 15 mm	07746-0040300

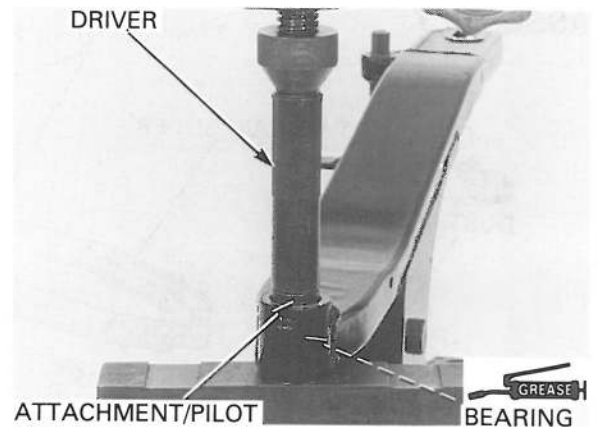

Install the bearing with the mark facing out.

Apply grease to the new left side needle bearing. Press the new left side needle bearing into the swingarm so that the needle bearing outer surface is 4.0 mm (0.16 in) below the outer edge of the swingarm pivot bearing cavity.

TOOLS:

Driver	07749-0010000
Attachment	07946-MJ00200
	Not available in U.S.A. or
Attachment, 28 X 30 mm	07946-1870100

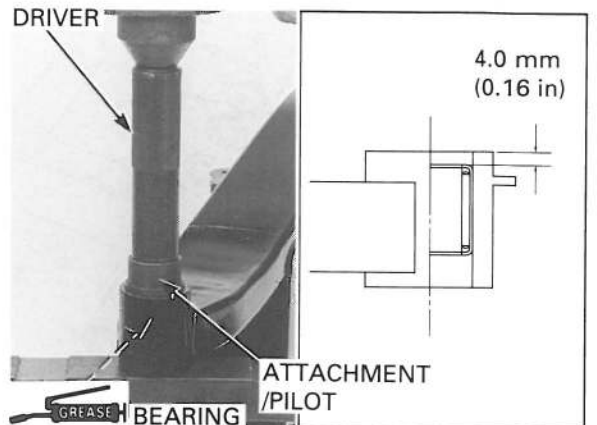

Install the new snap ring into the right pivot.

TOOL:

Snap ring pliers	07914-3230001
-------------------------	---------------



REAR WHEEL/BRAKE/SUSPENSION

ASSEMBLY

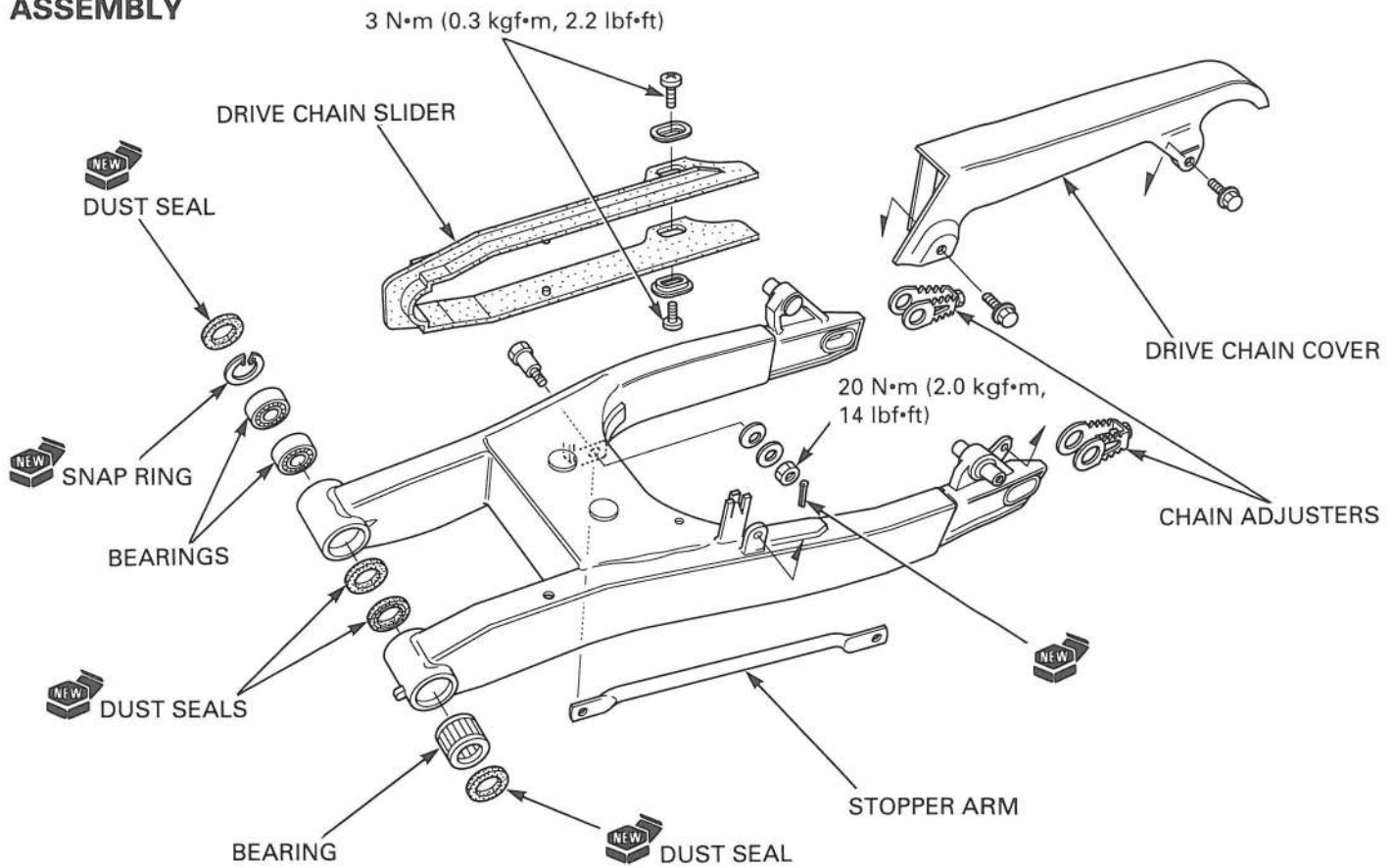

Apply grease to the new dust seal lips.

Apply oil to the pivot collars outer and sliding surface.

Install the dust seals and pivot collars to the swingarm right side pivot.

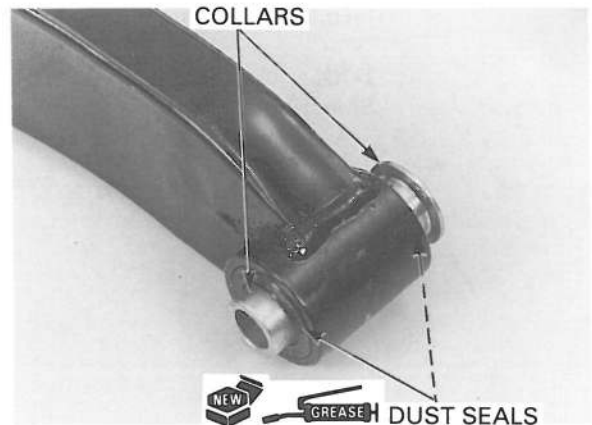

Apply grease to the new dust seal lips.

Apply oil to the pivot collars outer and sliding surface.

Install the dust seals and pivot collars to the swingarm left side pivot.

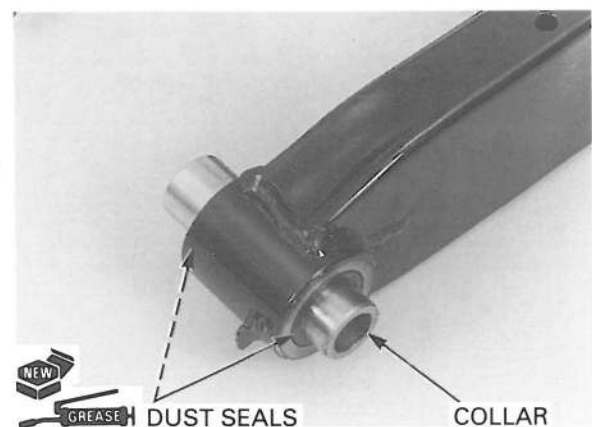

Install the right and left drive chain adjusters.

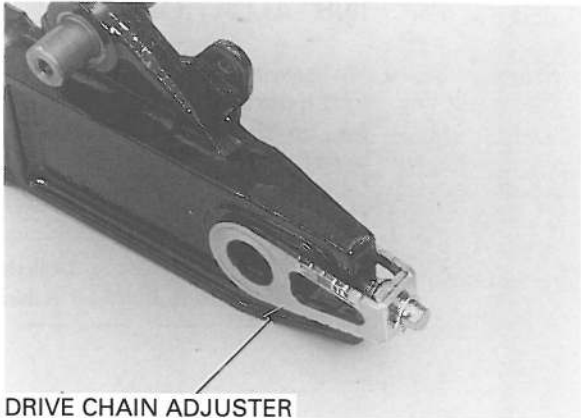

DRIVE CHAIN ADJUSTER

Install the stopper arm, bolt, washers and nut. Tighten the nut to the specified torque.

TORQUE: 20 N·m (2.0 kgf·m, 14 lbf·ft)

Install the new cotter pin to secure the nut.

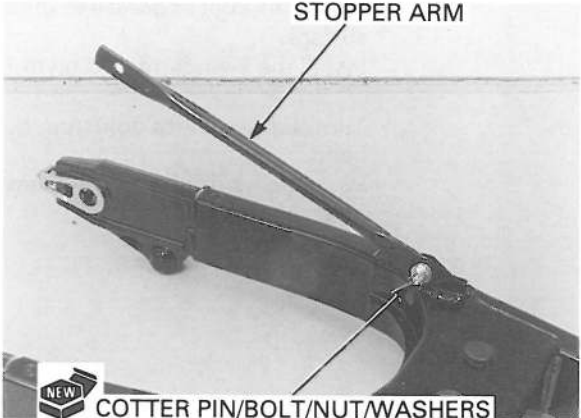

STOPPER ARM

COTTER PIN/BOLT/NUT/WASHERS

Install the drive chain slider aligning the hole on the chain slider to the pin on the swingarm.

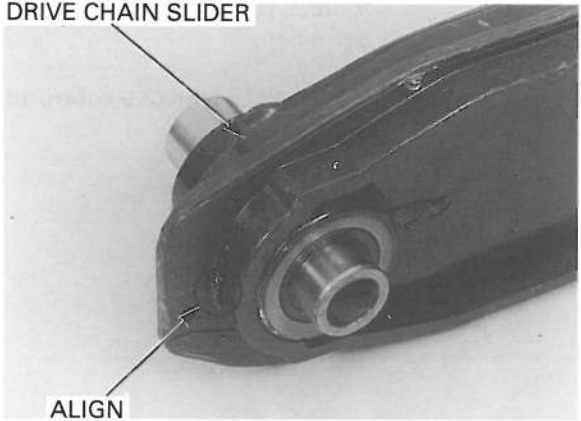

DRIVE CHAIN SLIDER

ALIGN

Clean and apply a locking agent to the drive chain slider screw threads.

Install the collars and screws. Tighten the screws to the specified torque.

TORQUE: 3 N·m (0.3 kgf·m, 2.2 lbf·ft)

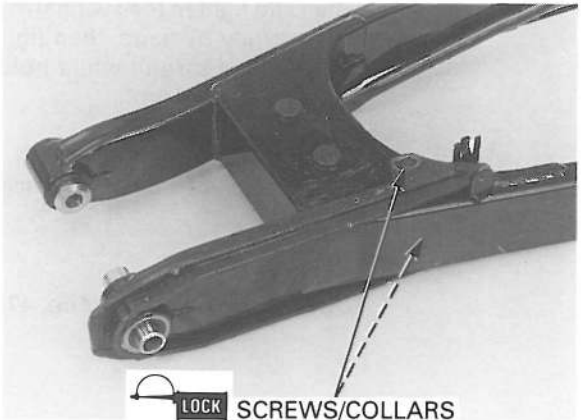

LOCK SCREWS/COLLARS

INSTALLATION

Place swingarm into frame.
Install the swingarm adjusting bolt.
Be sure that the tip of the bolt does not protrude inward.

NOTE:

If the end of the adjusting bolt does protrude, it will not be possible to install the swingarm.

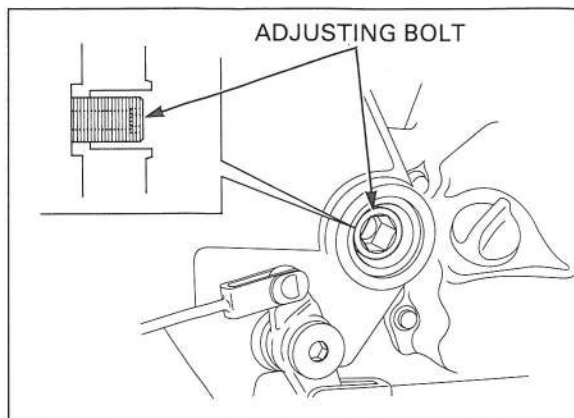

Apply thin coat of grease to the swingarm pivot bolt surface.
Install the swingarm and pivot bolt.

Turn the swingarm adjusting bolt completely in by hand.
Push the pivot bolt's hex shank into the adjusting bolt's socket head.

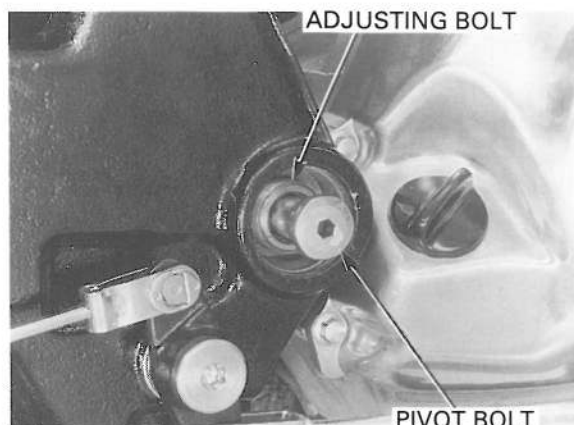

Tighten the swingarm pivot adjusting bolt with the pivot bolt.

TORQUE: 25 N·m (2.5 kgf·m, 18 lbf·ft)

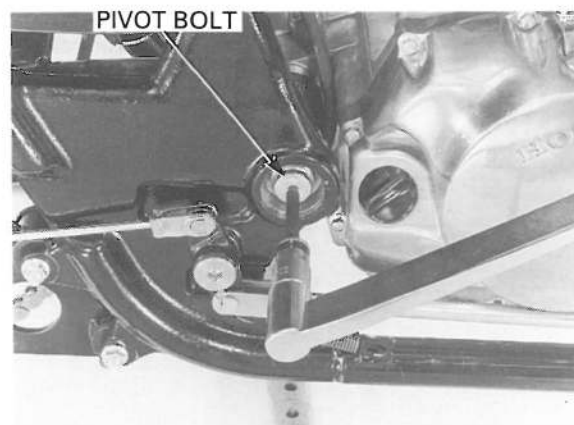

Install and tighten the swingarm pivot adjusting bolt lock nut fully by hand, then tighten the lock nut to the specified torque while holding the pivot bolt using the special tool.

TOOL:

Swingarm pivot lock nut wrench 07GMA-KT70200
Not available in U.S.A.

TORQUE: 64 N·m (6.5 kgf·m, 47 lbf·ft)

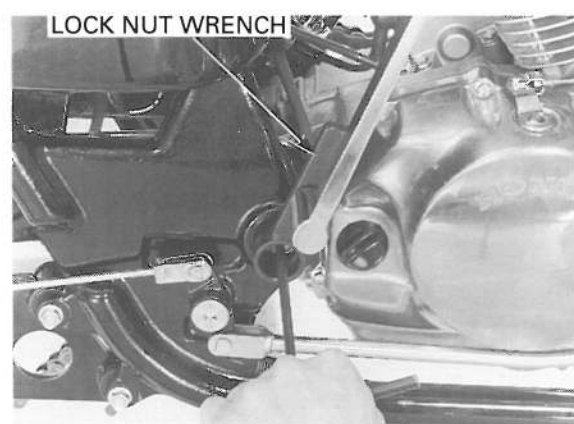

Tighten the swingarm pivot nut to the specified torque.

TORQUE: 88 N•m (9.0 kgf•m, 65 lbf•ft)

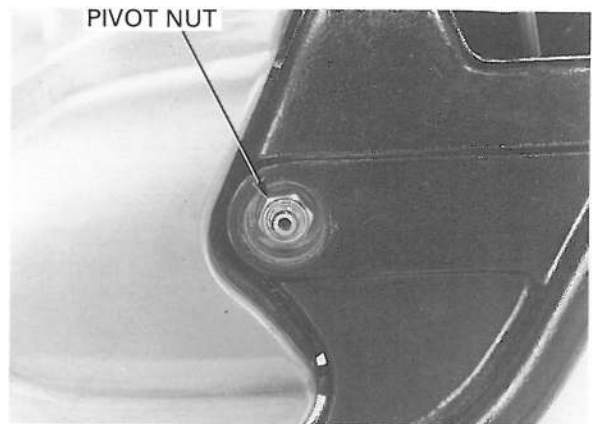

Install the pivot bolt caps.

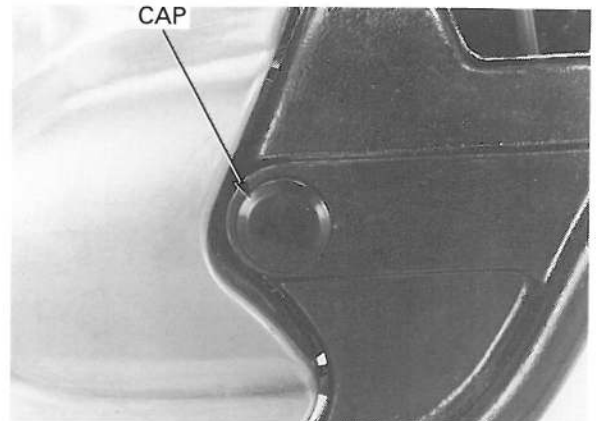

Install the drive chain cover by aligning the set plate with the tab on the swingarm.

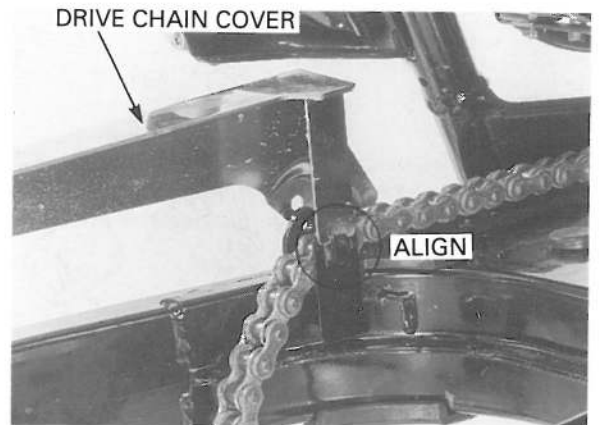

Install and tighten the bolts securely.

Install the right and left shock absorbers (page 14-19).

Install the rear wheel (page 14-10).

Install the muffler (page 2-8).

Adjust the drive chain (page 3-18).

Adjust the rear brake pedal free play (page 3-24).

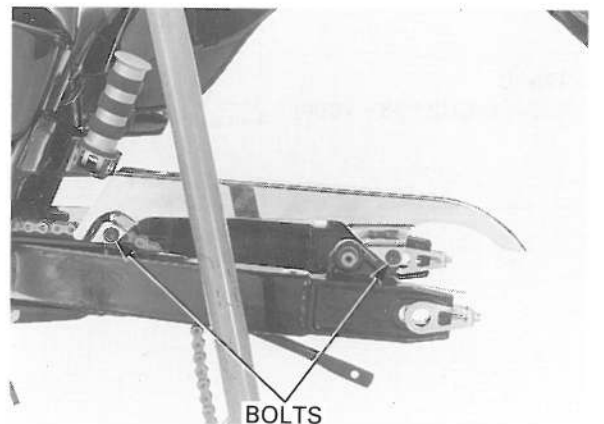

HYDRAULIC BRAKE

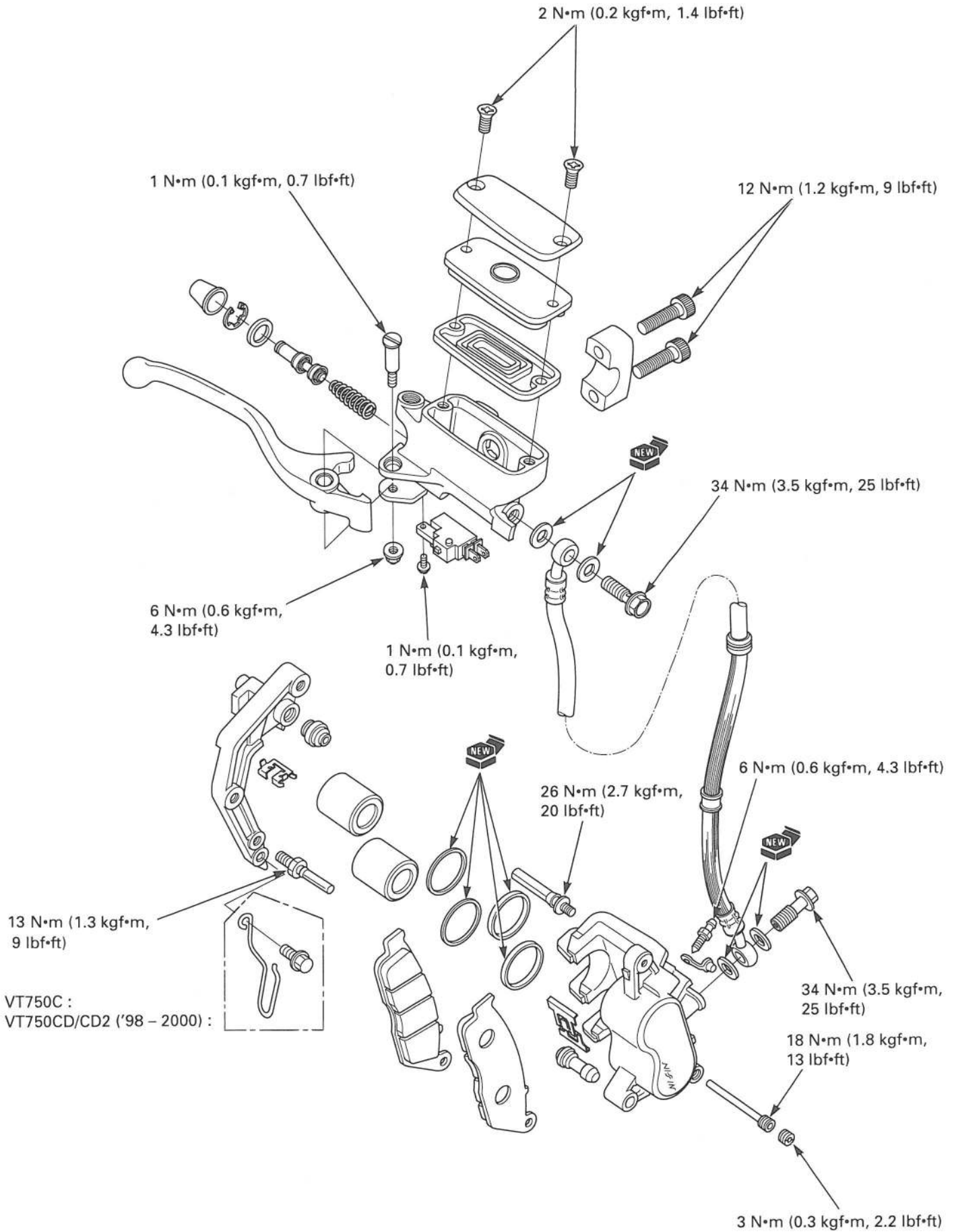

15. HYDRAULIC BRAKE

SERVICE INFORMATION	15-1	BRAKE PAD/DISC	15-5
TROUBLESHOOTING	15-2	MASTER CYLINDER	15-7
BRAKE FLUID REPLACEMENT/ AIR BLEEDING	15-3	BRAKE CALIPER	15-13

SERVICE INFORMATION

GENERAL

▲ WARNING

A contaminated brake disc or pad reduces stopping power. Discard contaminated pads and clean contaminated disc with a high quality brake degreasing agent.

CAUTION:

- *Support the brake caliper with a piece of wire so that it does not hang from the brake hose. Do not twist the brake hose.*
- *Reusing drained fluids can impair braking efficiency.*
- *Avoid spilling brake fluid on painted, plastic or rubber parts. Place a rag or shop towel over these parts whenever the system is serviced.*

- Never allow contaminants (dirt, water, etc.) to get into an open reservoir.
- Always use fresh DOT 4 brake fluid from a sealed container when servicing the system. Do not mix different types of fluid as they may not be compatible.
- Spilled brake fluid will severely damage instrument lenses and painted surfaces. It is also harmful to some rubber parts. Be careful whenever you remove the reservoir cap: make sure the from reservoir is horizontal first.
- Do not reuse the sealing washers. Replace with new ones.
- Once the hydraulic system has been operated, or if the brake feel spongy, the system must be bled.
- Always check brake operation before riding the motorcycle.
- Always replace the brake pads is pairs to ensure even disc pressure.
- Always check brake operation before riding the motorcycle.

15

SPECIFICATIONS

Unit: mm (in)

ITEM	STANDARD	SERVICE LIMIT
Brake fluid	DOT4	—
Brake pad wear indicator	—	To groove
Brake disc thickness	5.8 – 6.2 (0.23 – 0.24)	5 (0.2)
Brake disc runout	—	0.30 (0.012)
Master cylinder I.D.	11.000 – 11.043 (0.4331 – 0.4348)	11.05 (0.435)
Master piston O.D.	10.957 – 10.984 (0.4314 – 0.4324)	10.945 (0.4309)
Caliper cylinder I.D.	27.000 – 27.050 (1.0630 – 1.0650)	27.06 (1.065)
Caliper piston O.D.	26.935 – 26.968 (1.0604 – 1.0617)	26.93 (1.060)

HYDRAULIC BRAKE

TORQUE VALUES

Brake caliper mounting bolt	30 N•m (3.1 kgf•m, 22 lbf•ft)	ALOC bolt: replace with a new one
Caliper pin bolt	26 N•m (2.7 kgf•m, 20 lbf•ft)	
Bracket pin bolt	13 N•m (1.3 kgf•m, 9 lbf•ft)	
Pad pin	18 N•m (1.8 kgf•m, 13 lbf•ft)	
Pad pin plug	3 N•m (0.3 kgf•m, 2.2 lbf•ft)	
Brake caliper bleeder	6 N•m (0.6 kgf•m, 4.3 lbf•ft)	
Brake lever pivot bolt	1 N•m (0.1 kgf•m, 0.7 lbf•ft)	
Brake lever pivot nut	6 N•m (0.6 kgf•m, 4.3 lbf•ft)	
Master cylinder holder bolt	12 N•m (1.2 kgf•m, 9 lbf•ft)	
Master cylinder cover screw	2 N•m (0.2 kgf•m, 1.4 lbf•ft)	
Front brake light switch screw	1 N•m (0.1 kgf•m, 0.7 lbf•ft)	
Brake hose oil bolt	34 N•m (3.5 kgf•m, 25 lbf•ft)	

TOOLS

Snap ring pliers 07914-3230001

TROUBLESHOOTING

Brake lever soft or spongy

- Air in the hydraulic system
- Leaking hydraulic system
- Contaminated brake disc/pad
- Worn caliper piston seal
- Worn brake pad/disc
- Contaminated caliper
- Caliper not sliding properly
- Worn master cylinder piston cup
- Worn brake pad/disc
- Low fluid level
- Clogged fluid passage
- Warped/deformed brake disc
- Sticking/worn caliper piston
- Sticking/worn master cylinder piston
- Contaminated master cylinder
- Bent brake lever/pedal

Brake lever hard

- Sticking/worn caliper piston
- Caliper not sliding properly
- Clogged/restricted fluid passage
- Worn caliper piston seal
- Sticking/worn master cylinder piston
- Bent brake lever/pedal

Brake grab or pull to one side

- Contaminated brake pad/disc
- Misaligned wheel
- Clogged/restricted brake hose joint
- Warped/deformed brake disc
- Caliper not sliding properly

Brakes drag

- Contaminated brake disc/pad
- Warped/deformed brake disc
- Caliper not sliding properly
- Misaligned wheel

BRAKE FLUID REPLACEMENT/AIR BLEEDING

⚠ WARNING

A contaminated brake disc or pad reduces stopping power. Discard contaminated pads and clean contaminated disc with a high quality brake degreasing agent.

CAUTION:

- Do not allow foreign material to enter the system when filling the reservoir.
- Avoid spilling fluid on painted, plastic or rubber parts. Place a rag over these parts whenever the system is serviced.
- Use only DOT 4 brake fluid from a sealed container.
- Do not mix different types of fluid. They are not compatible.

BRAKE FLUID DRAINING

For the front brake, turn the handlebar to the left until the reservoir is level. Remove the screws, reservoir cover, set plate and diaphragm.

Connect the bleed tube to the bleed valve.

Loosen the bleed valve and pump the brake lever until no more fluid flows out of the bleed valve.

BRAKE FLUID FILLING/BLEEDING

Close the bleed valve.

Fill the reservoir with DOT 4 brake fluid from a sealed container.

Connect a commercially available brake bleeder to the bleed valve.

Pump the brake bleeder and loosen the bleed valve. Add brake fluid when the fluid level in the reservoir is low.

NOTE:

- Check the fluid level often while bleeding the brake to prevent air from being pumped into the system.
- When using a brake bleeding tool, follow the manufacturer's operating instructions.

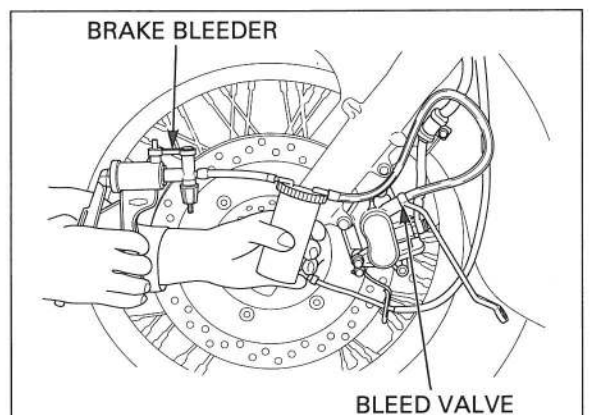
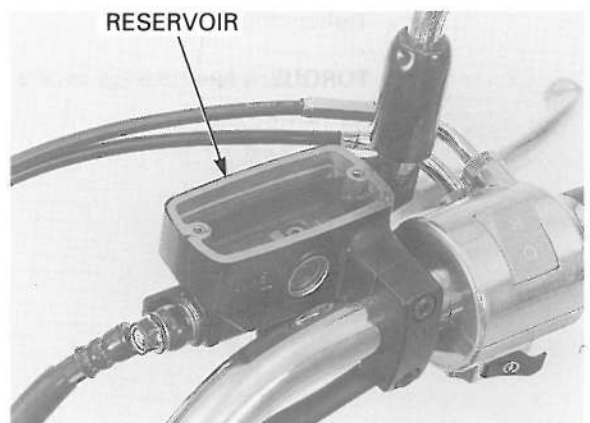
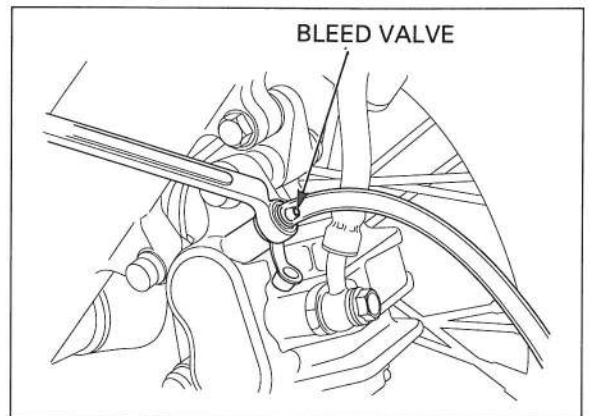
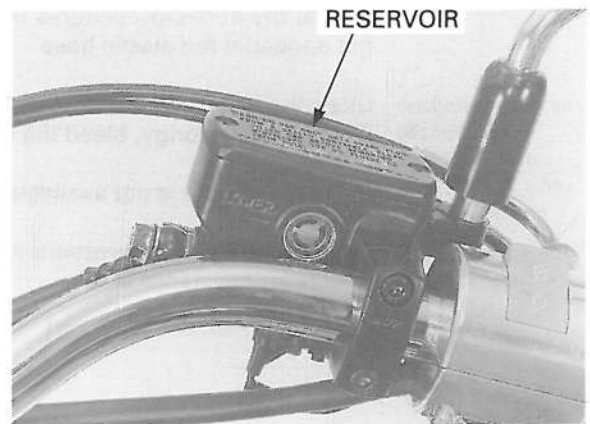

HYDRAULIC BRAKE

Repeat the above procedures until air bubbles do not appear in the plastic hose.

If air is entering the bleeder from around the bleed valve threads, seal the threads with teflon tape.

Close the bleed valve and operate the brake lever. If it still feels spongy, bleed the system again.

If a brake bleeder is not available, use the following procedure:

Pump up the system pressure with the brake lever until lever resistance is felt.

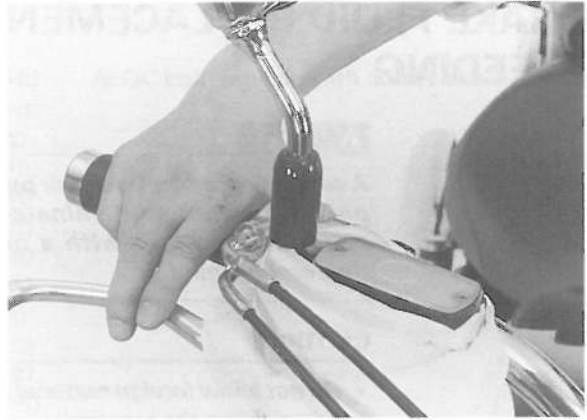

Connect a bleed hose to the bleed valve and bleed the system as follows:

1. Squeeze the brake lever. Open the bleed valve 1/2 turn and close it.

NOTE:

Do not release the brake lever until the bleed valve has been closed.

2. Release the brake lever slowly and wait several seconds after it stops moving.

Repeat steps 1 and 2 until air bubbles do not appear in the bleed valve.

Tighten the bleed valve.

TORQUE: 6 N·m (0.6 kgf·m, 4.3 lbf·ft)

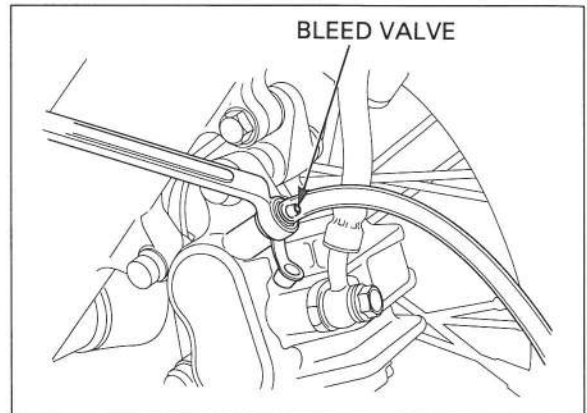

Fill the reservoir to the upper level mark with DOT 4 brake fluid from a sealed container.



Install the diaphragm, set plate and reservoir cover.
Tighten the screws to the specified torque.

TORQUE: 2 N·m (0.2 kgf·m, 1.4 lbf·ft)

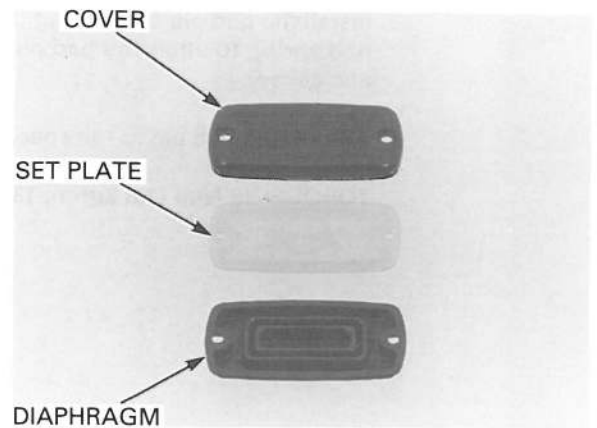

BRAKE PAD/DISC

⚠ WARNING

A contaminated brake disc or pad reduces stopping power. Discard contaminated pads and clean contaminated disc with a high quality brake degreasing agent.

BRAKE PAD REPLACEMENT

Always replace the brake pads in pairs to ensure even disc pressure.

Push the caliper pistons all the way in by pushing the caliper body inward to allow installation of new brake pads.

NOTE:

Check the brake fluid level in the brake master cylinder reservoir as this operation causes the level to rise.

Remove the pad pin plug and loosen the pad pin.

Remove the pad pin and the brake pads.

Install new pads so that their ends rest on the pad retainer on the bracket properly.

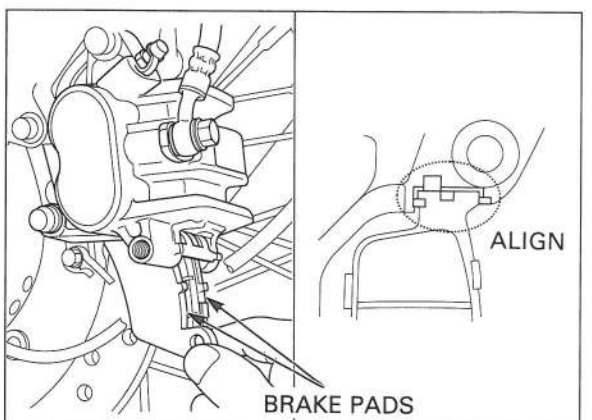
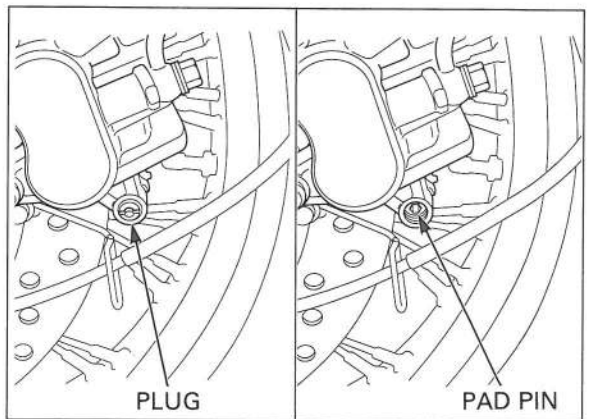
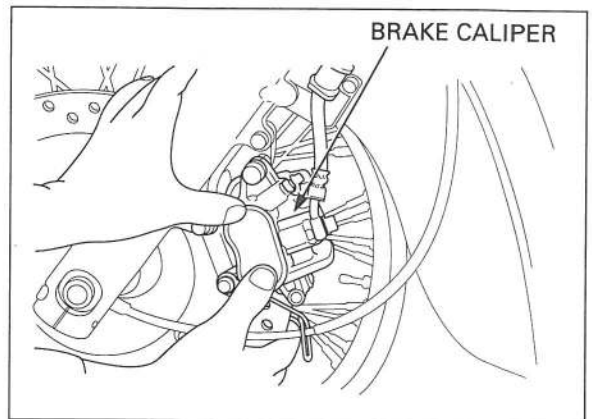

HYDRAULIC BRAKE

Install the pad pin by pushing the pads against the pad spring to align the pad pin holes in the pads and caliper.

Tighten the pad pin to the specified torque.

TORQUE: 18 N·m (1.8 kgf·m, 13 lbf·ft)

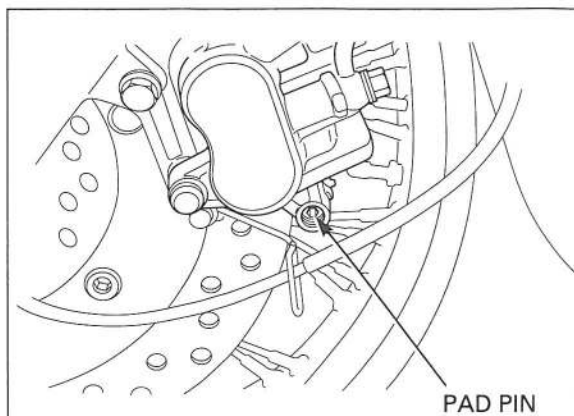

Install and tighten the pad pin plug to the specified torque.

TORQUE: 3 N·m (0.3 kgf·m, 2.2 lbf·ft)

⚠ WARNING

After replacement, operate the brake lever to seat the caliper pistons against the pads.

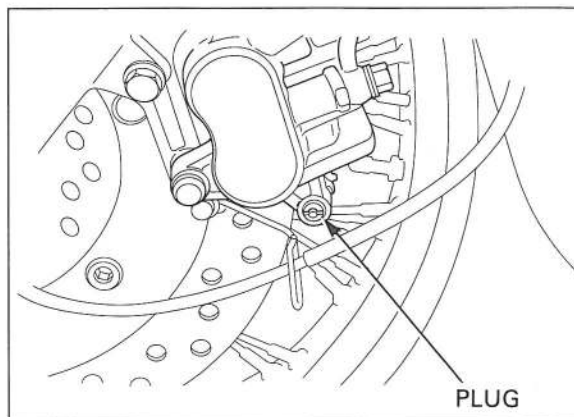

BRAKE DISC INSPECTION

Visually inspect the disc for damage or cracks.

Measure the brake disc thickness at several points.

SERVICE LIMIT: 5 mm (0.2 in)

Replace the brake disc if the smallest measurement is less than the service limit.

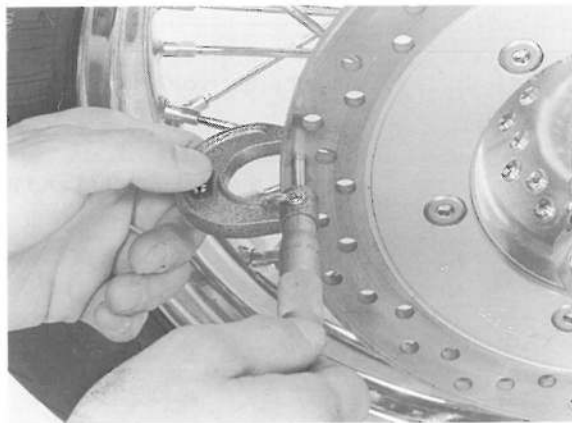

Check the brake disc for warpage.

SERVICE LIMIT: 0.30 mm (0.012 in)

Check the wheel bearings for excessive play, if the warpage exceeds the service limit.
Replace the brake disc if the wheel bearings are normal.

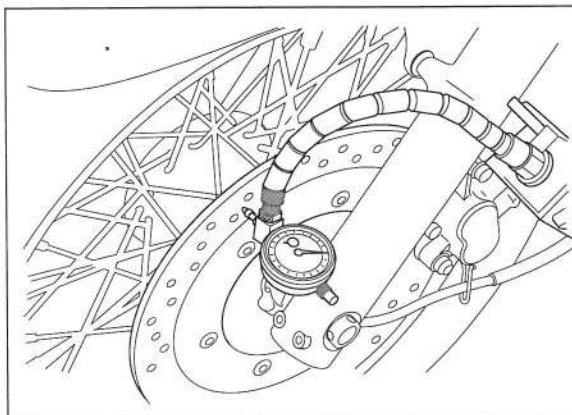

MASTER CYLINDER

CAUTION:

- *Avoid spilling brake fluid on painted, plastic or rubber parts. Place a rag or shop towel over these parts whenever the system is serviced.*
- *When removing the oil hose, cover the end of the hose to prevent contamination.*

REMOVAL

Drain the brake fluid (page 15-3).
Remove the right rear view mirror.

Disconnect the brake light switch connectors.

Disconnect the brake hose by removing the oil bolt and sealing washers.

Remove the master cylinder holder bolts, holder and master cylinder.

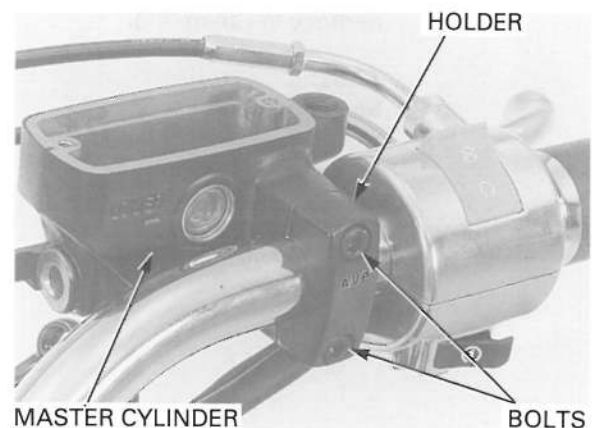
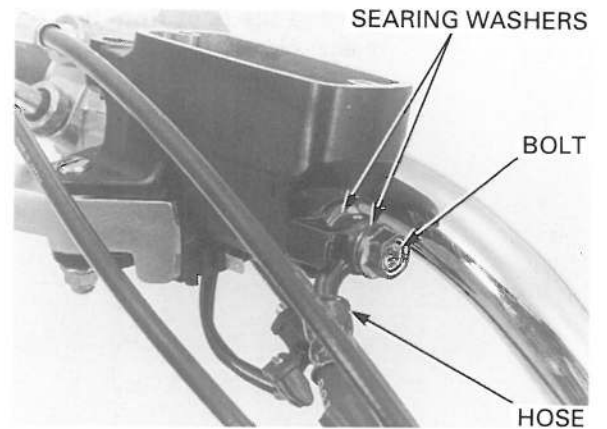
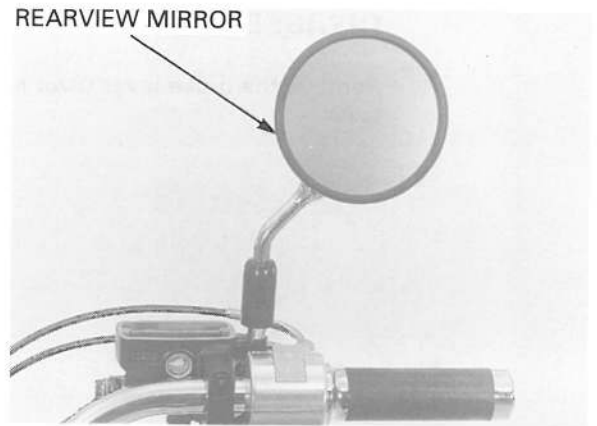

HYDRAULIC BRAKE

DISASSEMBLY

Remove the brake lever pivot nut, bolt and brake lever.

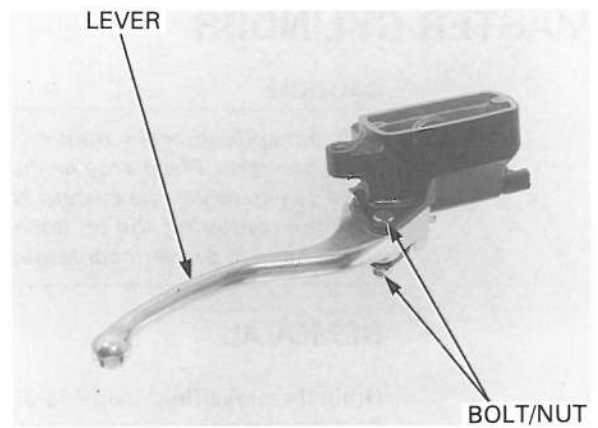

Remove the screw and brake light switch.

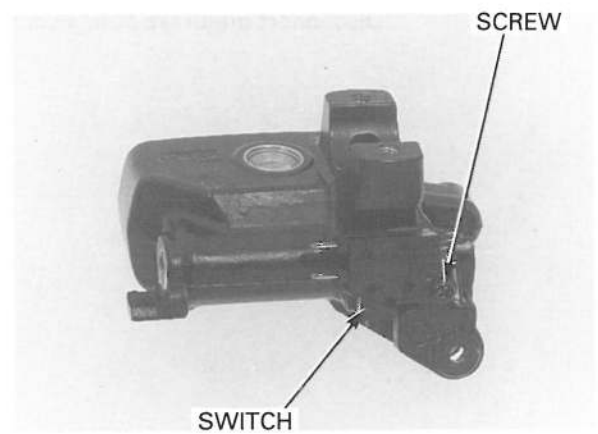

Remove the boot from the master cylinder and master piston.

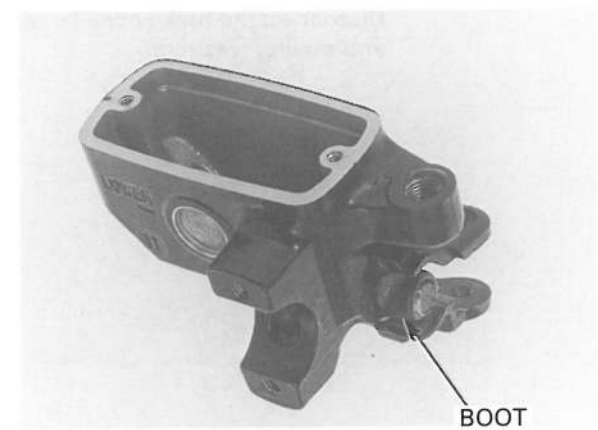

Remove the snap ring.

TOOL:
Snap ring pliers

07914-3230001

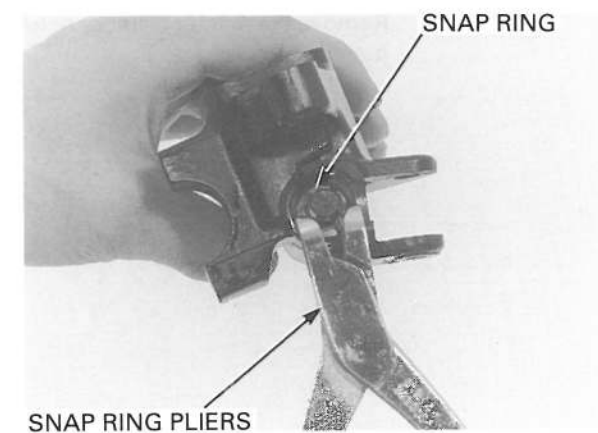

Remove the master piston and spring from the master cylinder.

Clean the master cylinder, reservoir and master piston with clean brake fluid.

NOTE:

- Replace the master piston, spring, cups, spring seat and snap ring as a set whenever they are disassembled.
- Be sure that each part is free from the dust or dirt before reassembly.
- Never allow contaminants (dirt, water, etc.) to get into an open reservoir.

INSPECTION

Check the piston cups and for wear, deterioration or damage.
Check the master cylinder and piston for scoring, scratches or damage.

Measure the master cylinder I.D.

SERVICE LIMIT: 11.05 mm (0.435 in)

Measure the master piston O.D.

SERVICE LIMIT: 10.945 mm (0.4309 in)

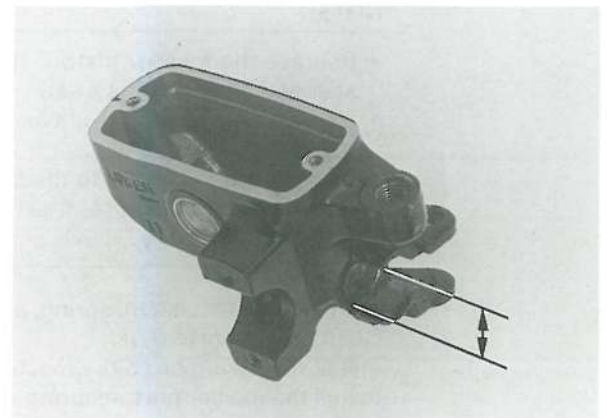
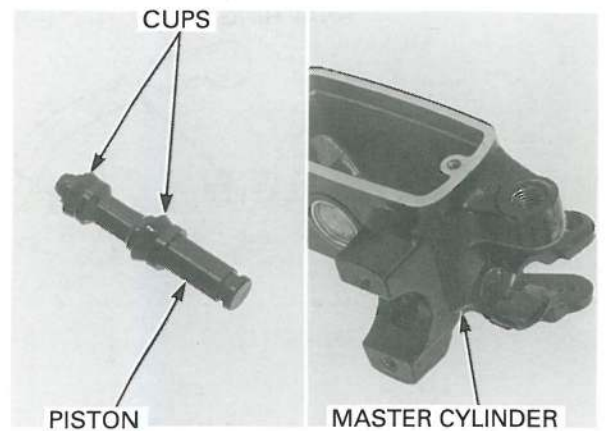
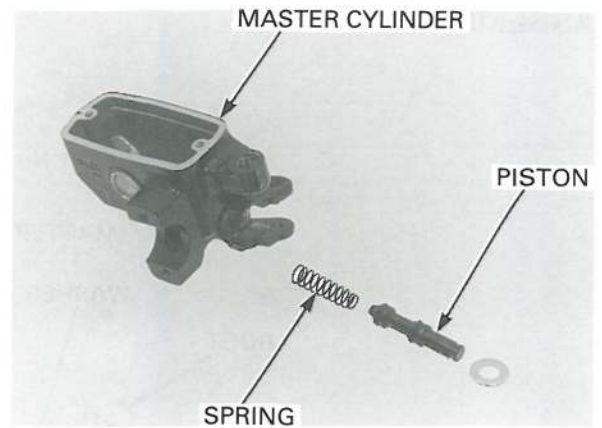

HYDRAULIC BRAKE

ASSEMBLY

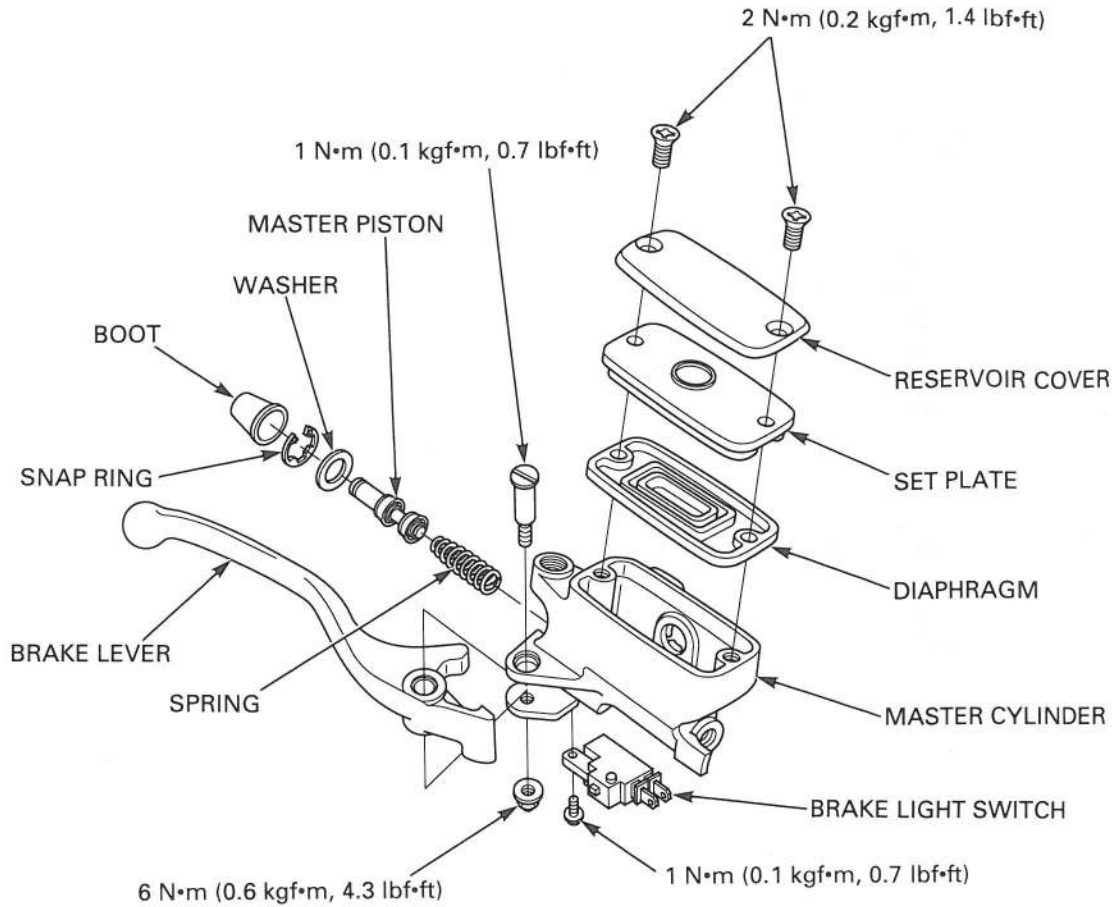

NOTE:

- Replace the master piston, spring, cups, spring seat and snap ring as a set.
- Replace the boot if it is wear, deterioration or damage.
- Apply silicone grease to the boot inner surface.
- Be sure that each part is free from the dust or dirt before reassembly.

Coat the master piston, spring, and piston cups with clean DOT 4 brake fluid.
Install the spring onto the master piston end.
Install the master piston/spring and washer into the master cylinder.

CAUTION:

Do not allow the piston cup lips to turn inside out.

Install the snap ring into the groove in the master cylinder.

TOOL:

Snap ring pliers

07914-3230001

CAUTION:

Be certain the snap ring is firmly seated in the groove.

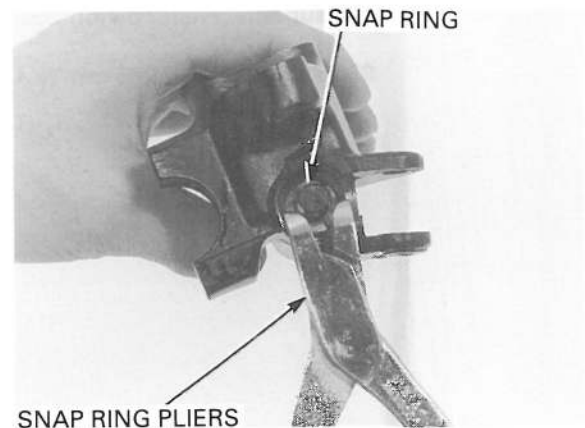
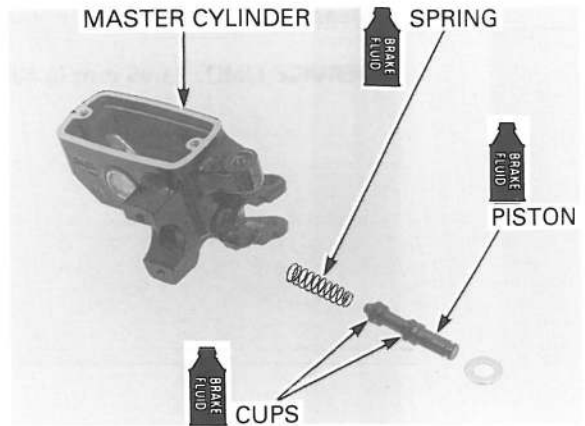

Install the boot into the master cylinder and the groove in the master piston.
Apply silicone grease to the brake lever contacting surface of the master cylinder and piston.

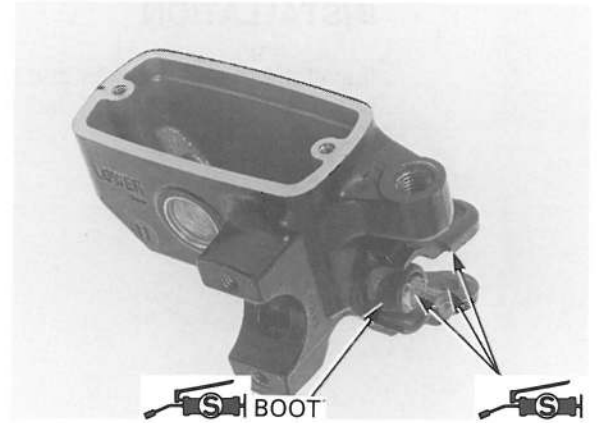

Install the brake light switch to the master cylinder aligning the brake light switch boss and master cylinder hole.

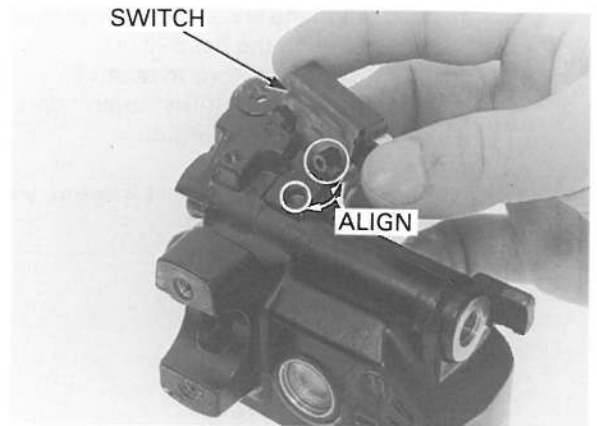

Install and tighten the screw to the specified torque.

TORQUE: 1 N·m (0.1 kgf·m, 0.7 lbf·ft)

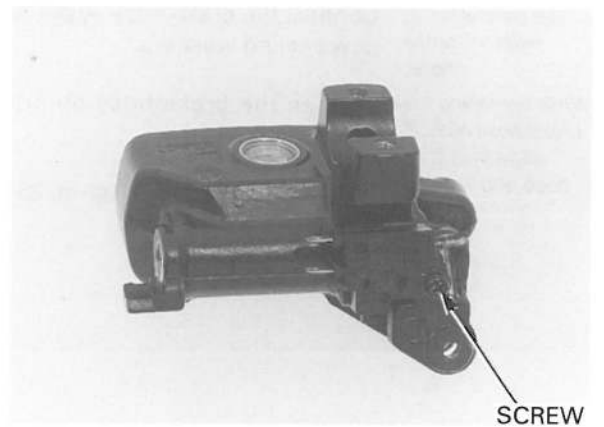

Apply grease to the brake lever pivot bolt.
Install the brake lever to the master cylinder.
Install and tighten the brake lever pivot bolt to the specified torque.

TORQUE: 1 N·m (0.1 kgf·m, 0.7 lbf·ft)

Install and tighten the brake lever pivot nut to the specified torque.

TORQUE: 6 N·m (0.6 kgf·m, 4.3 lbf·ft)

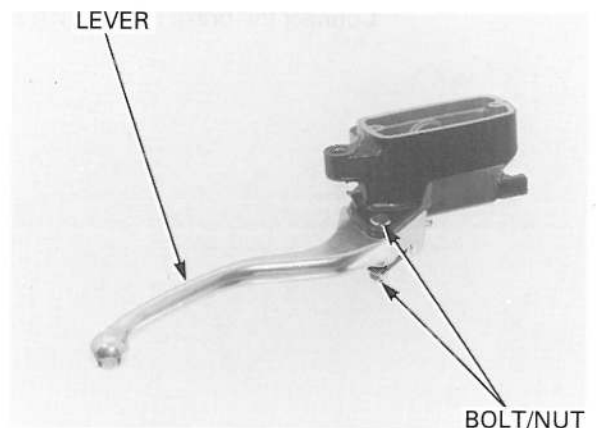

HYDRAULIC BRAKE

INSTALLATION

Install the master cylinder and the master cylinder holder with the "UP" mark facing up.

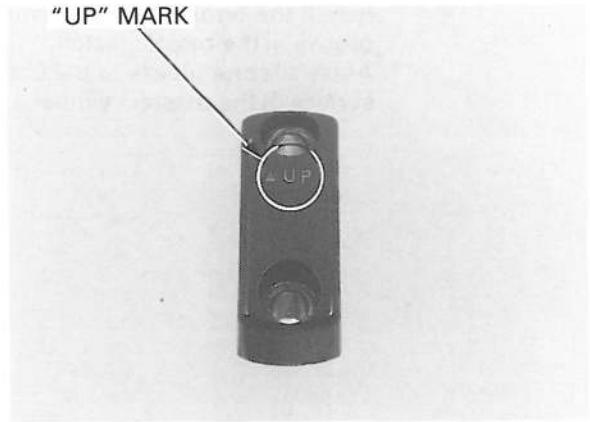

Align the end of the master cylinder with the punch mark on the handlebar. Install the front master cylinder bolts and tighten the upper bolt first, then tighten the lower bolt to the specified torque.

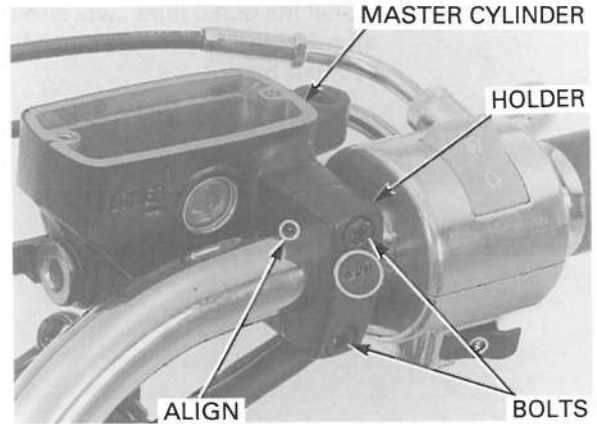

TORQUE: 12 N·m (1.2 kgf·m, 9 lbf·ft)

Be careful not to twist the brake hose.

Connect the brake hose eyelet with the oil bolt and new sealing washers.

While tightening the brake hose oil bolt, align the brake hose end with the stopper.

Tighten the brake hose oil bolt to the specified torque.

TORQUE: 34 N·m (3.5 kgf·m, 25 lbf·ft)

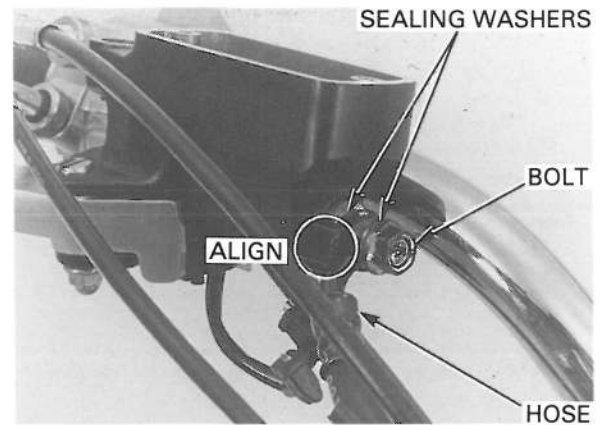

Connect the brake light switch connectors.

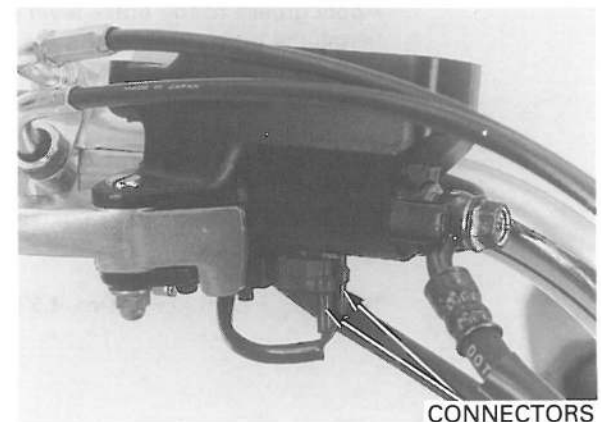

Install the right rear view mirror.

Refill the brake fluid (page 15-3).
Install the brake pad (page 15-5).

REARVIEW MIRROR

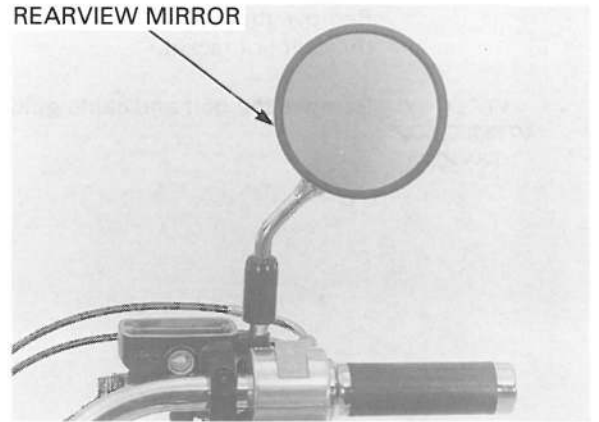

BRAKE CALIPER

CAUTION:

- *Avoid spilling brake fluid on painted, plastic or rubber parts. Place a rag or shop towel over these parts whenever the system is serviced.*
- *When removing the oil hose bolt, cover the end of the hose to prevent contamination.*

REMOVAL

Remove the brake pads (page 15-5).
Drain the brake fluid (page 15-3).

Remove the brake hose oil bolt and sealing washers and disconnect the brake hose from the front brake caliper.

Remove the front brake caliper mounting bolts and front brake caliper.

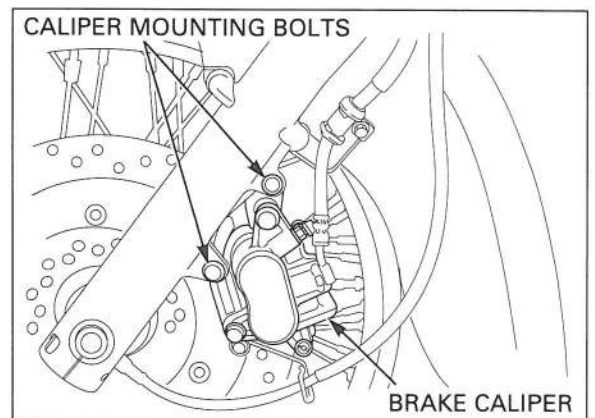
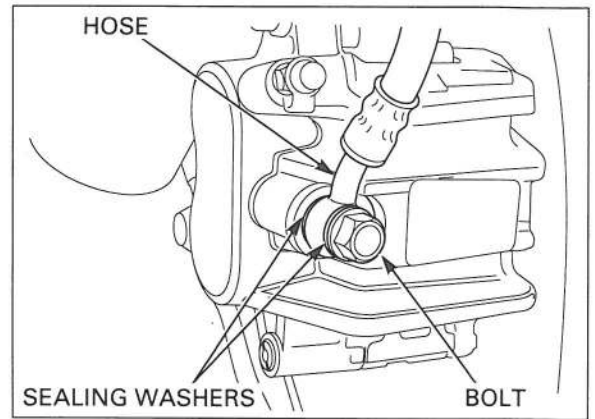

DISASSEMBLY

Do not remove the caliper and bracket pins unless replacement.

Remove the caliper bracket from the caliper body.

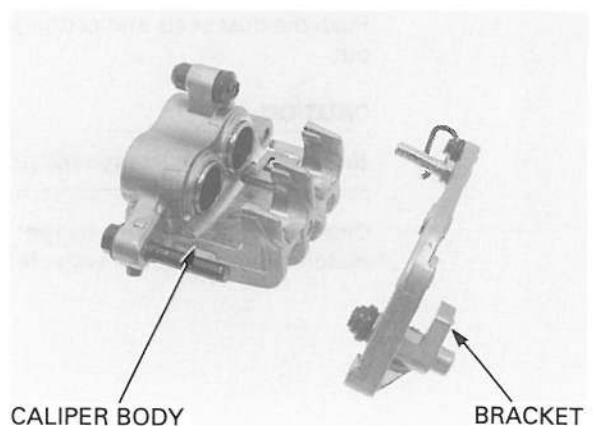

HYDRAULIC BRAKE

Remove the caliper pin boot and pad retainer from the caliper bracket.

*VT750C and
VT750CD/CD2
('98 - 2000) :*

Remove the bolt and cable guide.

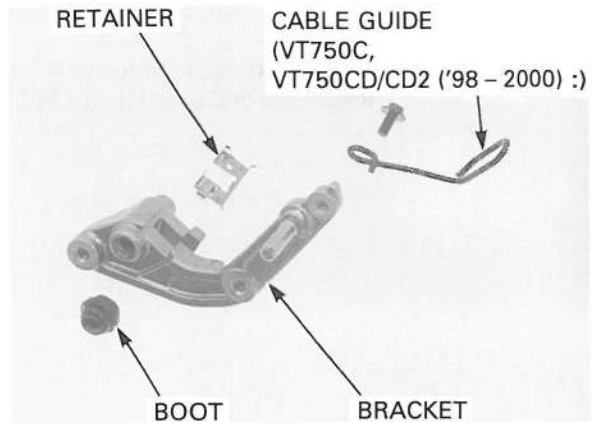

Remove the pad spring and bracket pin boot from the caliper body.

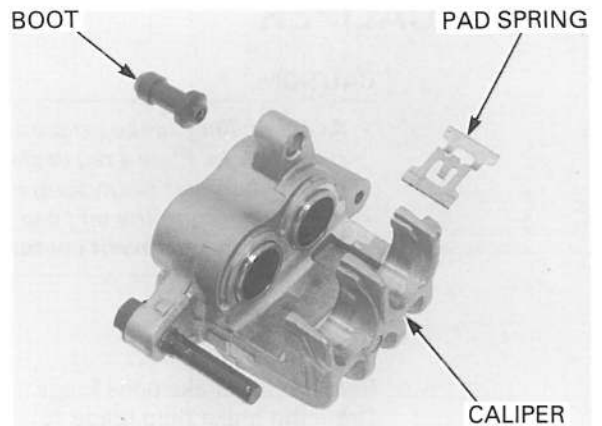

Place a shop towel over the pistons.
Position the caliper body with the pistons down and apply small squirts of air pressure to the fluid inlet to remove the pistons.

CAUTION:

Do not use high pressure air or bring the nozzle too close to the inlet.

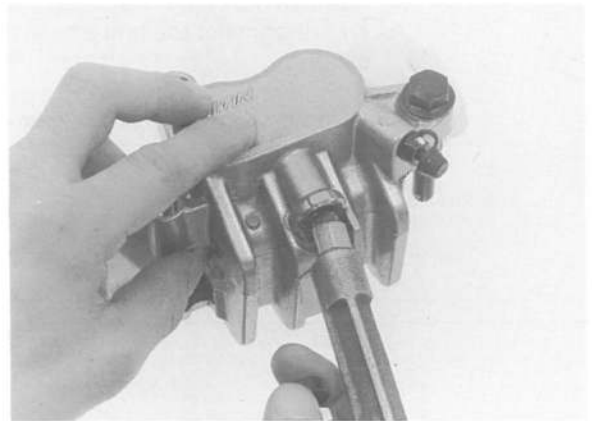

Push the dust seals and piston seals in and lift them out.

CAUTION:

Be careful not to damage the piston sliding surface.

Clean the seal grooves, caliper pistons and caliper piston sliding surfaces with clean brake fluid.

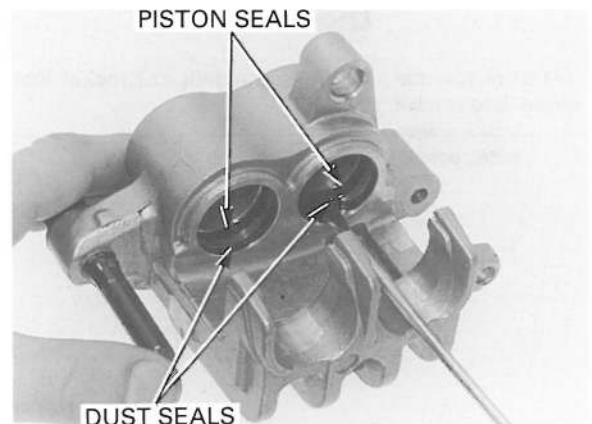

INSPECTION

Check the caliper cylinder and pistons for scoring, scratches or damage.

Measure the caliper cylinder I.D.

SERVICE LIMIT: 27.06 mm (1.065 in)

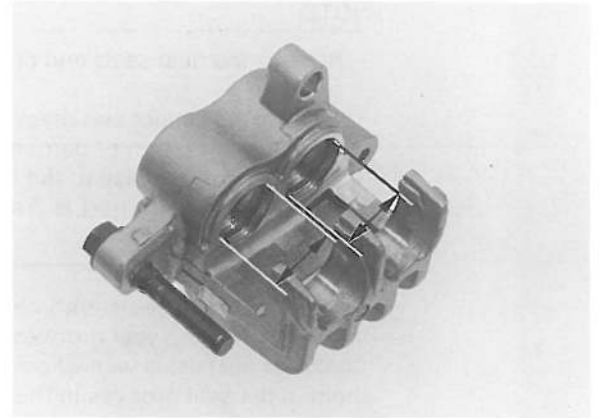

Measure the caliper piston O.D.

SERVICE LIMIT: 26.93 mm (1.060 in)

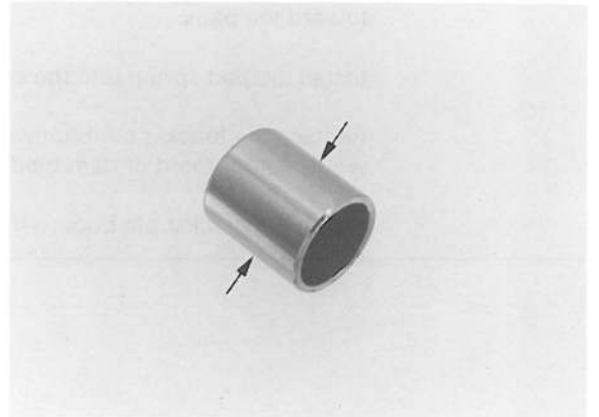

ASSEMBLY

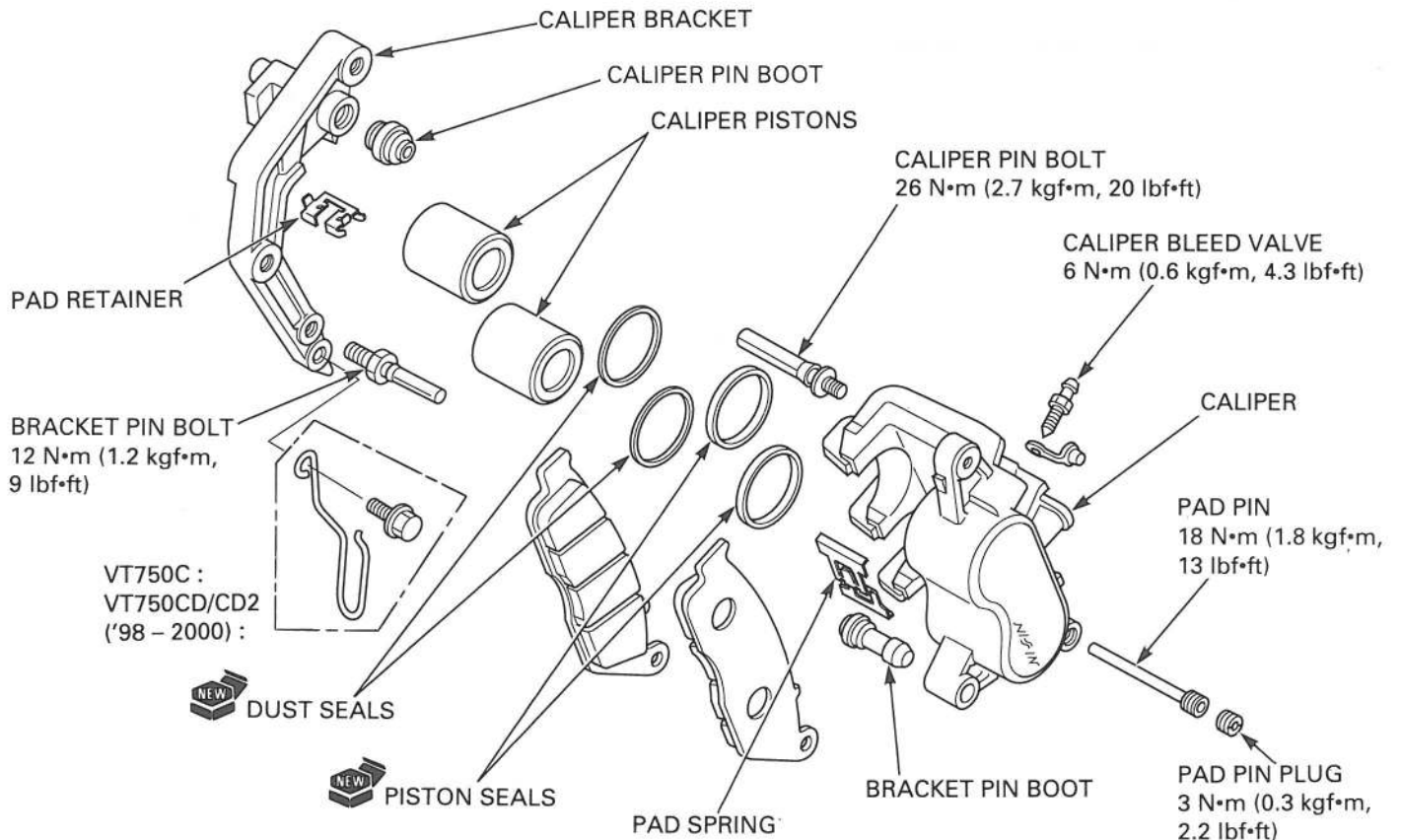

HYDRAULIC BRAKE

NOTE:

- Replace the dust seals and piston seals with new ones.
- Replace the caliper and bracket pin boots there is wear, deterioration or damage.
- Apply silicone grease to the boot inner surface.
- Be sure that each part is free from dust or dirt before reassembly.

Coat new piston seals with clean brake fluid and install them in the seal grooves in the caliper.
Coat new dust seals with silicone grease and install them in the seal grooves in the caliper.
Coat the caliper piston with clean brake fluid and install it into the caliper cylinder with the opening toward the pads.

Install the pad spring into the caliper body.

Replace the bracket pin boot with a new one if it is worn, deteriorated or damaged.

Install the bracket pin boot to the caliper body.

Replace the caliper pin boot with a new one if it is worn, deteriorated or damaged.

Install the caliper pin boot.

Apply Threebond #1521 or equivalent to the pad retainer-to-caliper bracket seating surface.
Install the pad retainer to the caliper bracket.

*VT750C and
VT750CD/CD2
(’98 – 2000):*

Install the speedometer cable guide to the caliper bracket.

Apply silicone grease to the caliper and bracket pins.
Install the caliper bracket over the caliper.

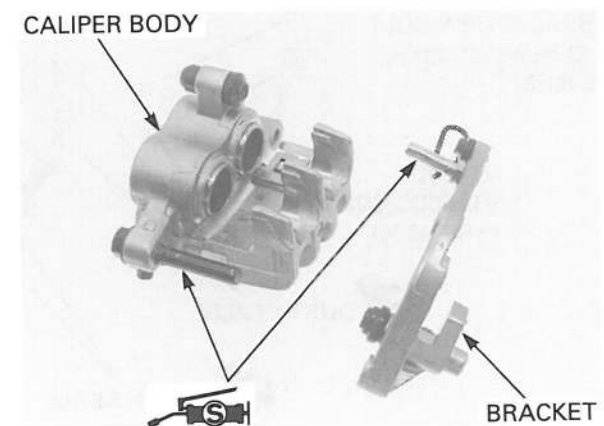
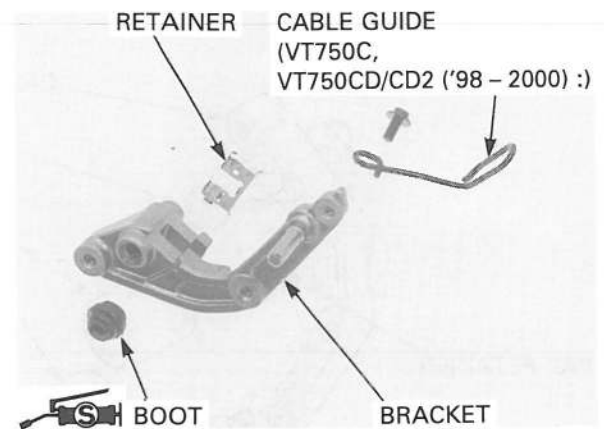
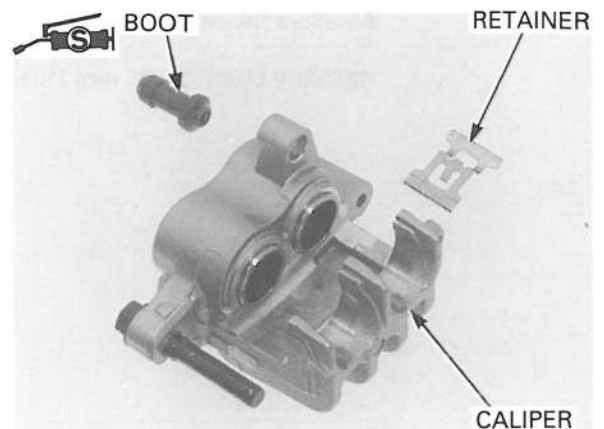
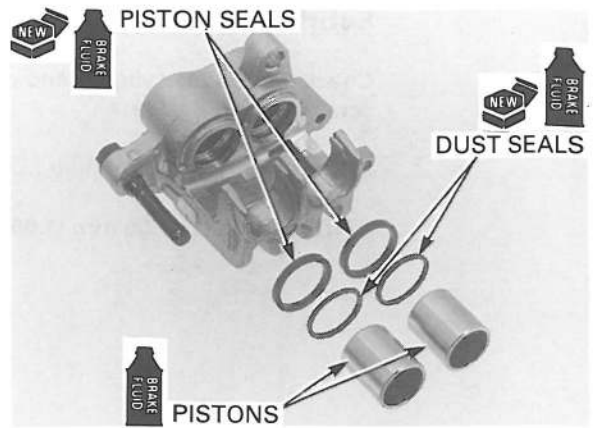

INSTALLATION

Install the front brake caliper to the front fork.
Install and tighten the new front caliper mounting bolts to the specified torque.

TORQUE: 30 N•m (3.1 kgf•m, 22 lbf•ft)

Install and tighten the speedometer wire guide lower mounting bolt securely.

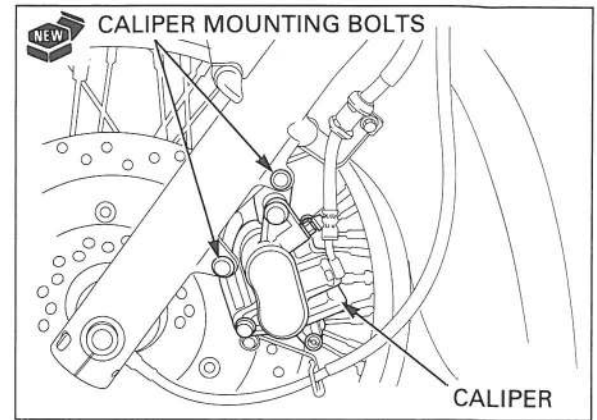

Be careful not to twist the brake hose.

Connect the brake hose to the brake caliper with new sealing washers.

While tightening the brake hose oil bolt, align the brake hose end with the stopper.

Install and tighten the brake hose oil bolt to the specified torque.

TORQUE: 34 N•m (3.5 kgf•m, 25 lbf•ft)

Refill the brake fluid (page 15-3).
Install the brake pads (page 15-5).

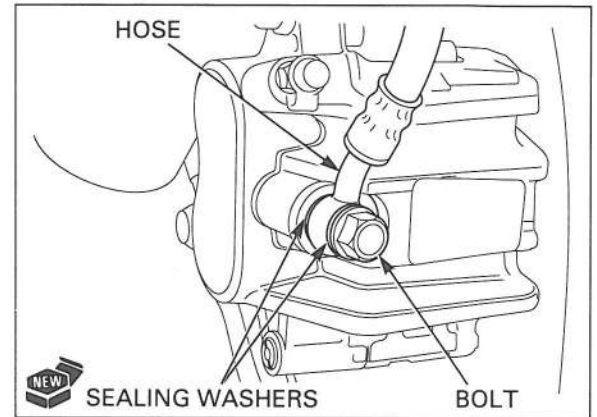

SYSTEM DIAGRAM

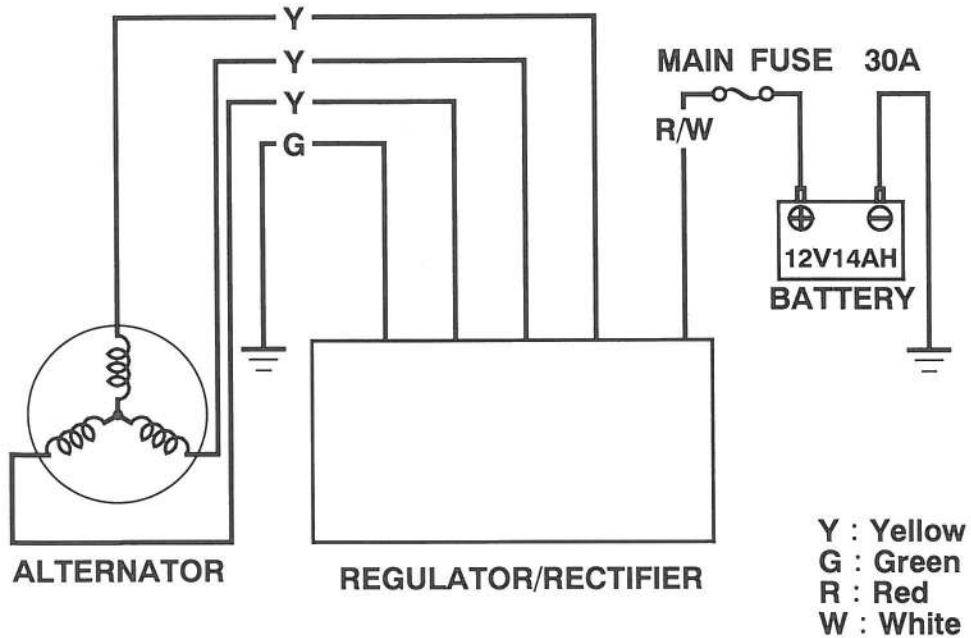
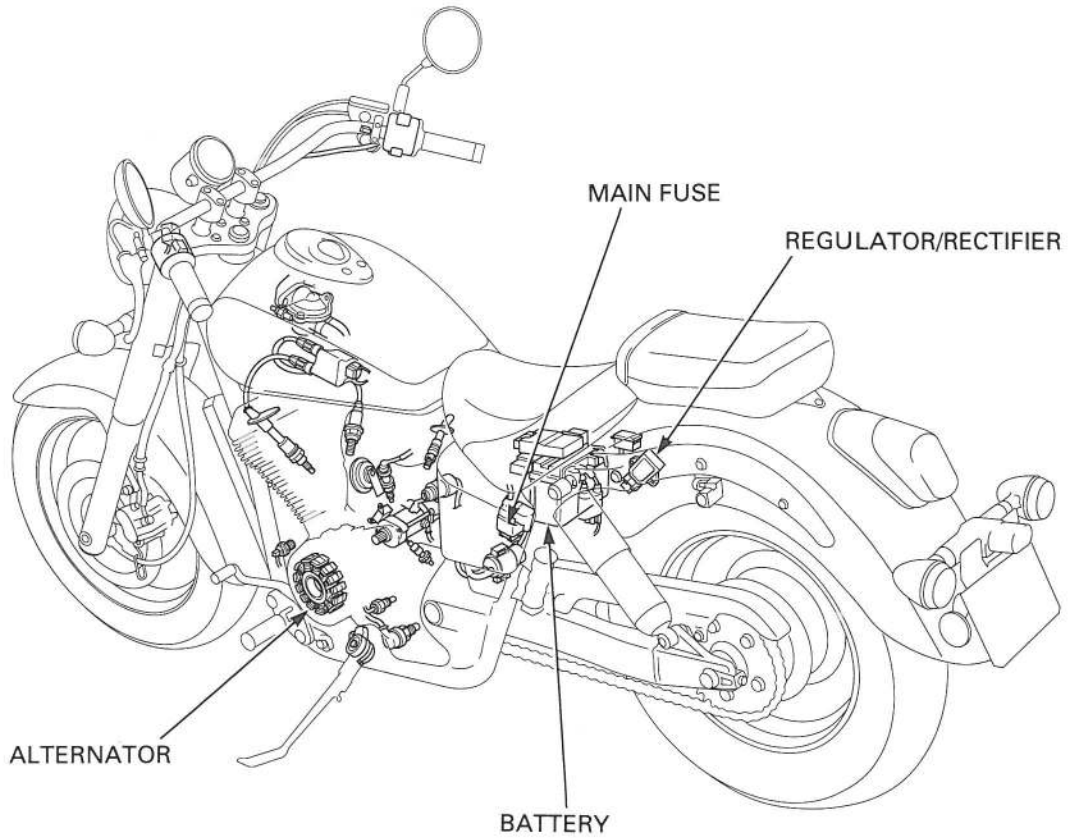

16. BATTERY/CHARGING SYSTEM

SYSTEM DIAGRAM	16-0	BATTERY	16-5
SERVICE INFORMATION	16-1	CHARGING SYSTEM INSPECTION	16-7
TROUBLESHOOTING	16-3	REGULATOR/RECTIFIER	16-9

SERVICE INFORMATION

GENERAL

⚠ WARNING

- *The battery gives off explosive gases; keep sparks, flames and cigarettes away. Provide adequate ventilation when charging or using the battery in an enclosed space.*
- *The battery contains sulfuric acid (electrolyte). Contact with skin or eyes may cause severe burns. Wear protective clothing and a face shield.*
 - *If electrolyte gets on your skin, flush with water.*
 - *If electrolyte gets on your eyes, flush with water for at least 15 minutes and call a physician immediately.*
- *Electrolyte is poisonous.*
 - *If swallowed, drink large quantities of water or milk and follow with milk of magnesia or vegetable oil and call a physician.*
- **KEEP OUT OF REACH OF CHILDREN.**

- Always turn off the ignition switch before disconnecting any electrical component.

CAUTION:

Some electrical components may be damaged if terminals or connectors are connected or disconnect while the ignition switch is ON and a current is present.

- For extended storage, remove the battery, give it a full charge and store it in a cool, dry space. For maximum service life, charge the stored battery every two weeks.
- For battery remaining in a stored motorcycle, disconnect the negative battery cable from the battery terminal.
- The battery can be damaged if overcharged or undercharged, or if left to discharge for long periods. These same conditions contribute to shortening the life-span of the battery. Even under normal use, the performance of the battery deteriorates after 2-3 years.
- Battery voltage may recover after battery charging, but under a heavy load, battery voltage will drop quickly and eventually the battery will be completely discharged. For this reason, the charging system is often suspected to be the problem. Battery overcharge often results in problems in the battery itself, which may appear to be an overcharge symptom. If one of the battery cells is shorted and the battery voltage does not increase, the regulator/rectifier supplies excess voltage to the battery. Under these conditions, the electrolyte level drops quickly.
- Before troubleshooting the charging system, check for proper use and maintenance of the battery. Check if the battery is frequently under a heavy load, such as having the headlight and taillight ON for long periods of time without riding the motorcycle.
- The battery will self-discharge when the motorcycle is not use. For this reason, charge the battery every two weeks to prevent sulfation from forming.
- Filling a new battery with electrolyte will produce some voltage, but in order to achieve maximum performance, always charge the battery. Also, the battery life is lengthened when it is initial-charged.
- When checking the charge system, always follow the steps in the troubleshooting flow chart (page 16-3).
- Alternator servicing may be done with the engine in the frame.

BATTERY/CHARGING SYSTEM

SPECIFICATIONS

ITEM		SPECIFICATIONS	
Battery	Capacity	12 V – 14 Ah	
	Current leakage	1.0 mA max	
	Voltage (20°C/68° F)	Fully charged	13.0 – 13.2 V
		Needs charging	Below 12.3 V
	Charging current	Normal	1.4 A/5 – 10 h
Quick		6.0 A/1 h max	
Alternator	Capacity	345 W/5,000 rpm	
	Charging coil resistance (20°C/68° F)	0.1 – 0.3 Ω	
Regulator/rectifier regulated voltage		14 – 15 V/4,000 rpm	

TORQUE VALUES

Battery case cover screw

10 N•m (1.0 kgf•m, 7 lbf•ft)

TROUBLESHOOTING

Battery undercharging (voltage not raised to regulated voltage).

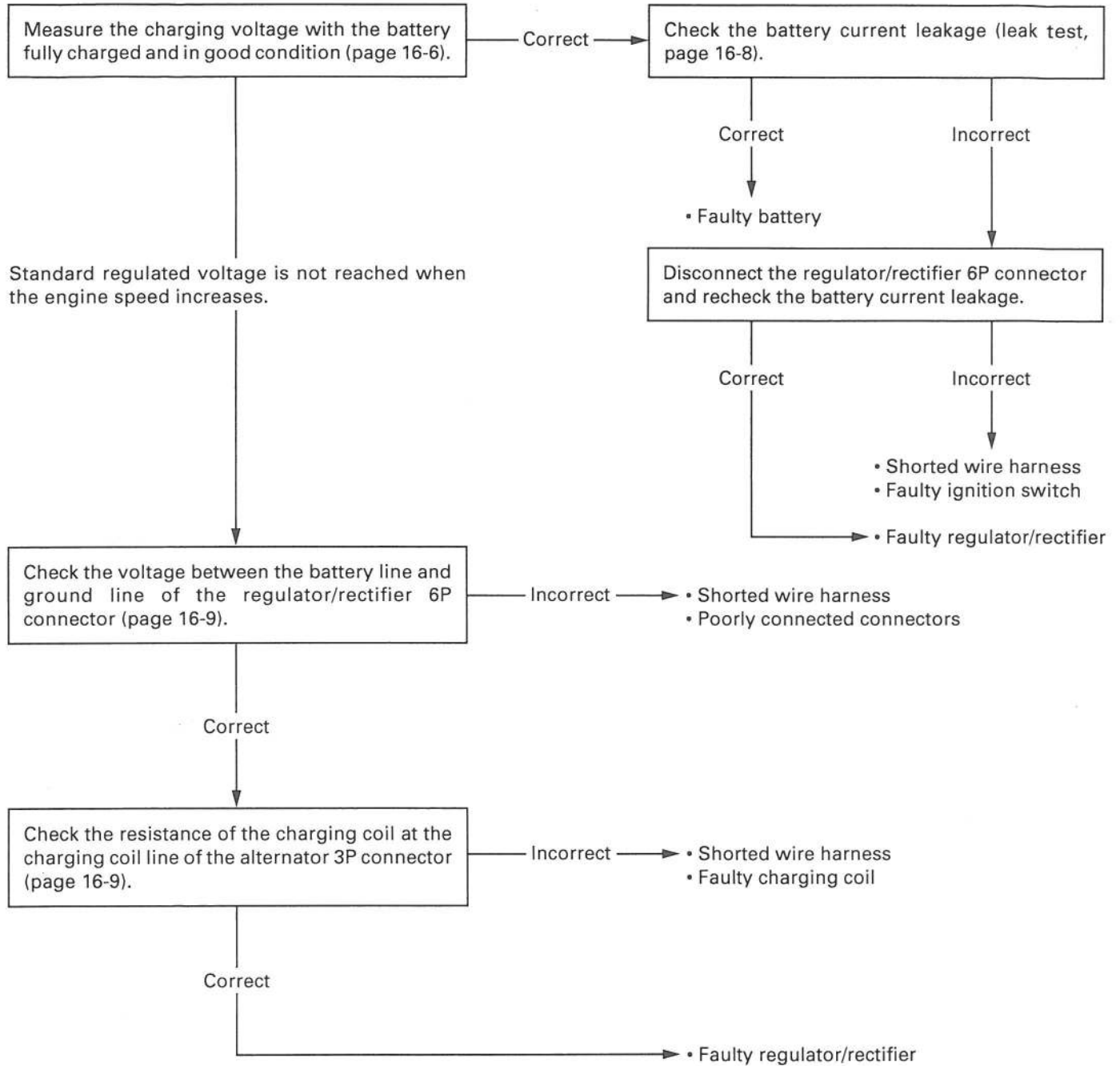

BATTERY/CHARGING SYSTEM

Battery overcharging (regulated voltage too high).

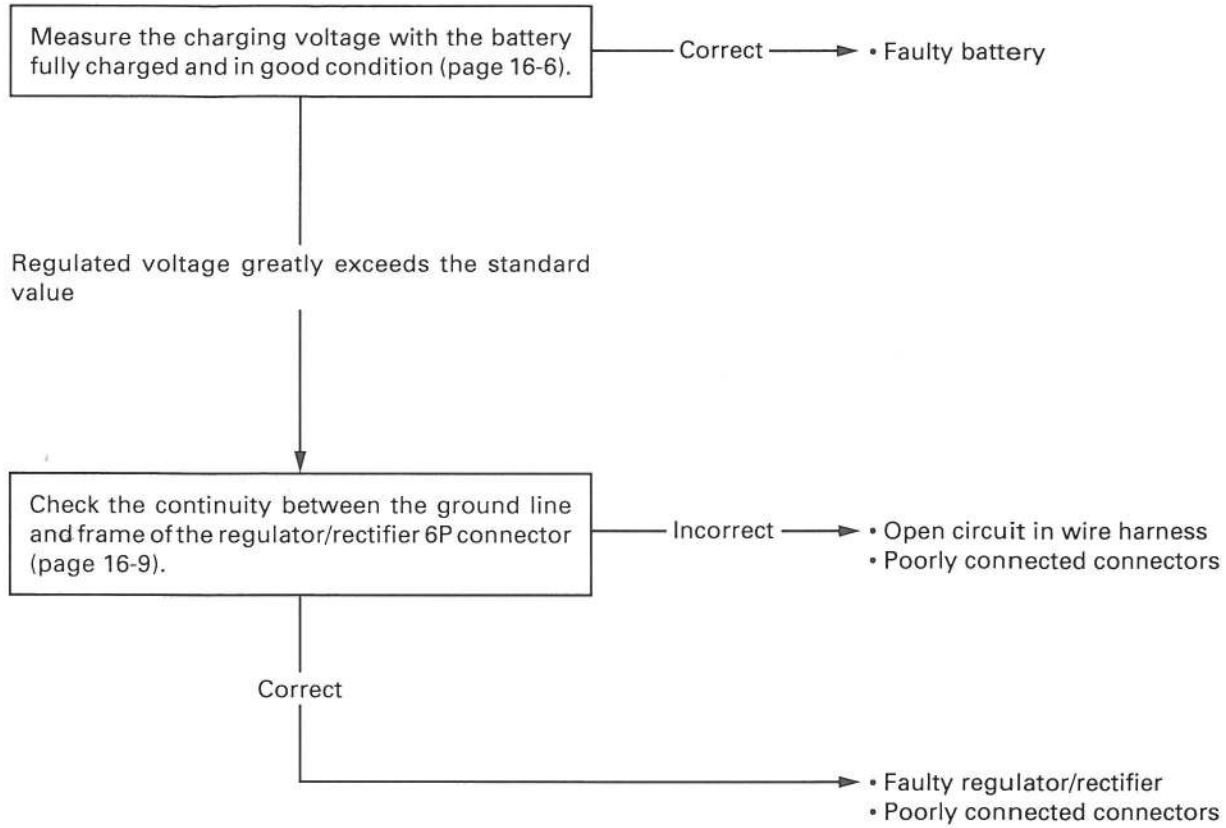

BATTERY

REMOVAL

Always turn the ignition switch OFF before removing or installing the battery.

- Remove the seat (page 2-2).
- Remove the ignition control module from the battery case cover.
- Remove the three screws and battery case cover.

Disconnect the battery negative cable first, then positive cable from the battery.

- Remove the bolt and battery negative cable.
- Remove the positive cable cover.
- Remove the bolt and battery positive cable.
- Pull the battery out of the battery case.

INSTALLATION

Place the battery into the case and connect the battery positive cable to the battery first from the left side, then connect the negative cable from the right side.

Coat the battery terminal with clean grease.

Install the battery case cover then tighten the three screws to the specified torque.

TORQUE: 10 N·m (1.0 kgf·m, 7 lbf·ft)

Install the ignition control module to the battery case cover.

Install the seat (page 2-2).

INSPECTION

Measure the battery voltage using a commercially available digital multimeter.

VOLTAGE: Fully charged: 13.0 – 13.2 V
Under charged: Below 12.3 V

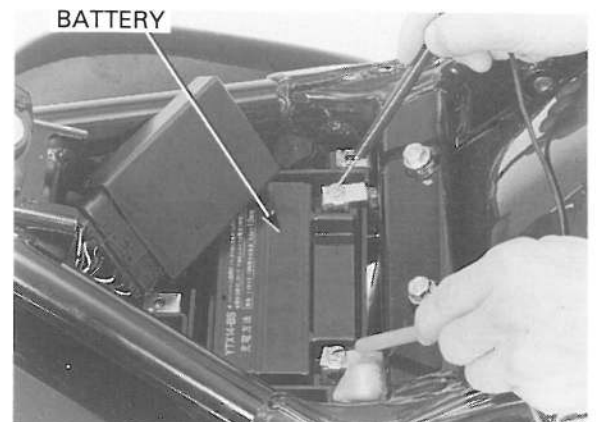
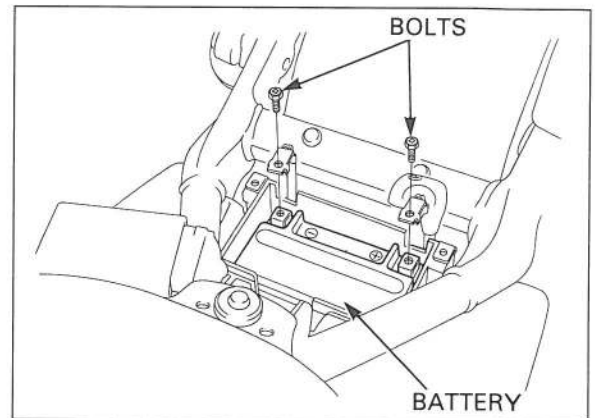
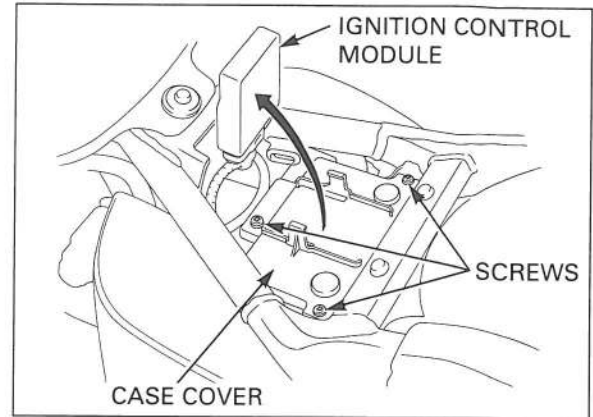

BATTERY CHARGING

⚠ WARNING

- *The battery gives off explosive gases; keep sparks, flames, and cigarettes away. Provide adequate ventilation when charging.*
- *The battery contains sulfuric acid (electrolyte). Contact with skin or eyes may cause severe burns. Wear protective clothing and a face shield.*
 - *If electrolyte gets on your skin, flush with water.*
 - *If electrolyte gets on your eyes, flush with water for at least 15 minutes and call a physician.*
- *Electrolyte is poisonous. If swallowed, drink large quantities of water or milk and follow with milk of magnesia or vegetable oil and call a physician.*
- *Turn power ON/OFF at the charger, not at the battery terminals.*

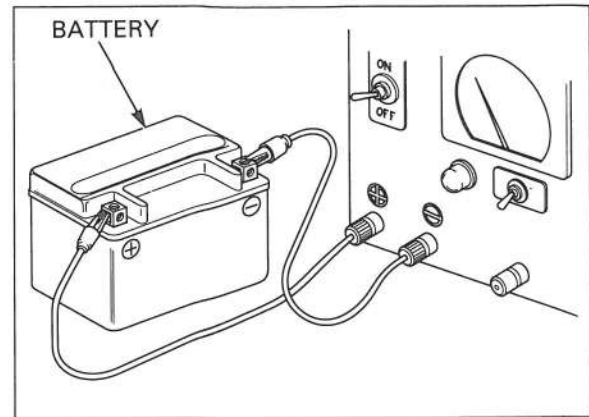

Remove the battery (page 16-5).

Connect the charger positive (+) cable to the battery positive (+) terminal.

Connect the charger negative (-) cable to the battery negative (-) terminal.

CHARGING CURRENT/TIME

Standard: 1.4A/5 – 10 h

Quick: 6.0 A/1 h max

CAUTION:

- *Quick-charging should only be done in an emergency; slow charging is preferred.*
- *For battery charging, do not exceed the charging current and time specified on the battery. Using excessive current or extending the charging time may damage the battery.*

CHARGING SYSTEM INSPECTION

NOTE:

- Measuring circuits with a large capacity that exceeds the capacity of the tester may cause damage to the tester. Before starting each test, set the tester at the high capacity range first, then gradually down to low capacity ranges in order to ensure that you have the correct range and do not damage the tester.
- When measuring small capacity circuits, keep the ignition switch off. If the switch is suddenly turned on during a test, the tester fuse may blow.

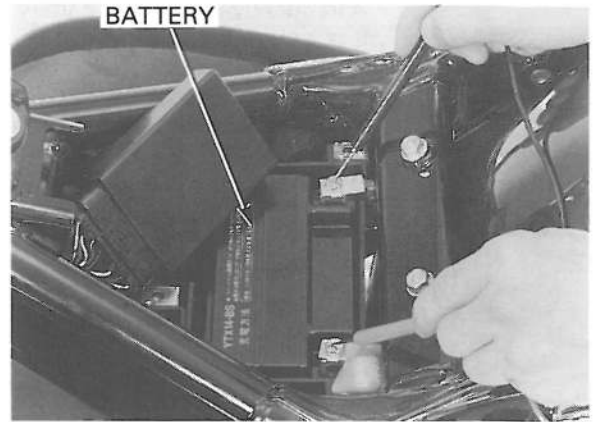

REGULATED VOLTAGE INSPECTION

⚠ WARNING

- *If the engine must be running to do some work, make sure the area is well-ventilated. Never run the engine in an enclosed area.*
- *The exhaust contains poisonous carbon monoxide gas that may cause loss of consciousness and may lead to death.*

Remove the battery (page 16-5) and install the fully charged battery.

Start the engine and warm it up to the operating temperature; stop the engine.

Connect the multimeter between the positive and negative terminals of the battery.

CAUTION:

- *To prevent short, make absolutely certain which are the positive and negative terminals or cable.*
- *Do not disconnect the battery or any cable in the charging system without first switching off the ignition switch. Failure to follow this precaution can damage the tester or electrical components.*

With the headlight to Lo beam, restart the engine. Measure the voltage on the multimeter when the engine runs at 5,000 rpm.

REGULATED VOLTAGE: 14 – 15 V/4,000 rpm

The battery is normal if the voltage reads the regulated voltage on the tester.

NOTE:

The speed at which voltage starts to rise cannot be checked as it varies with the temperature and loads of the generator.

BATTERY/CHARGING SYSTEM

A frequently discharged battery is an indication that it is deteriorated even if it proves normal in the regulated voltage inspection.

The charging circuit may be abnormal if any of the following symptoms is encountered:

1. Voltage not raised to regulated voltage (page 16-3)

- Open or shorted circuit in the charging system wire harness or poorly connected connector
- Open or shorted of the alternator
- Faulty regulator/rectifier

2. Regulated voltage too high (page 16-4)

- Poorly grounded voltage regulator/rectifier
- Faulty battery
- Faulty regulator/rectifier

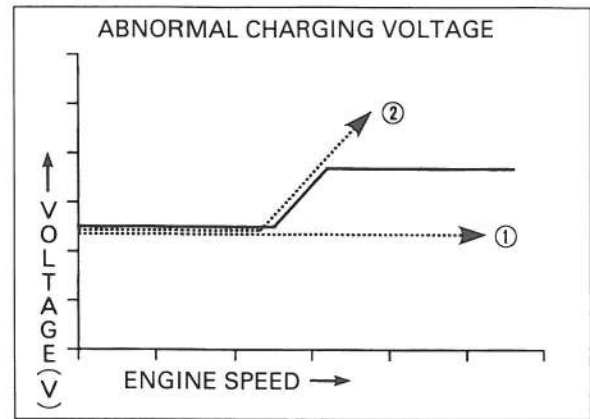
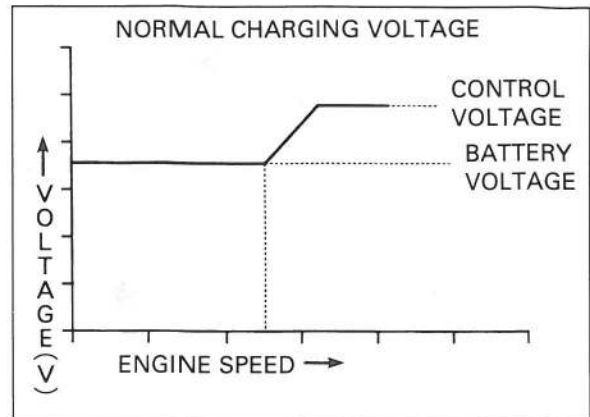

CURRENT LEAKAGE TEST

Remove the battery cover (page 16-5).

Turn the ignition switch OFF, and disconnect the ground (-) cable from the battery.

Connect the ammeter (+) probe to the battery ground cable and the ammeter (-) probe to the battery (-) terminal.

With the ignition switch OFF, check for current leakage.

NOTE:

- When measuring current using a tester, set it to a high range, and then bring the range down to an appropriate level. Current flow higher than the range selected may blow out the fuse in the tester.
- While measuring current, do not turn the ignition switch ON. A sudden surge of current may blow out the fuse in the tester.

SPECIFIED CURRENT LEAKAGE: 1.0 mA max.

If current leakage exceeds the specified value, a shorted circuit is likely.

Locate the short by disconnecting connections one by one and measuring the current.

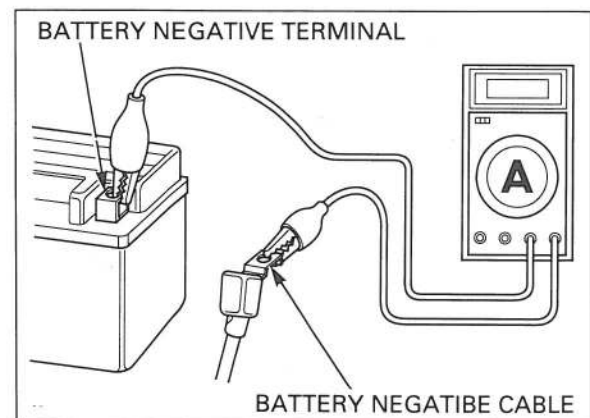

REGULATOR/RECTIFIER

WIRE HARNESS INSPECTION

Remove the left side cover (page 2-4).

Disconnect the regulator/rectifier 6P connector.
Check the connectors for loose or corroded terminals.

BATTERY LINE

Make sure the battery voltage between Red/White (+) and Green (-).

If there are no voltage, measure the following:

Item	Terminals	Specification
Battery charging line	Red/White (+) and ground (-)	Battery voltage should register
Ground line	Green and ground	Continuity exists

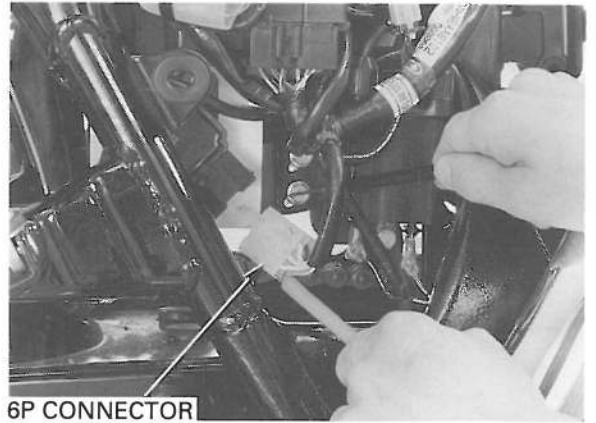
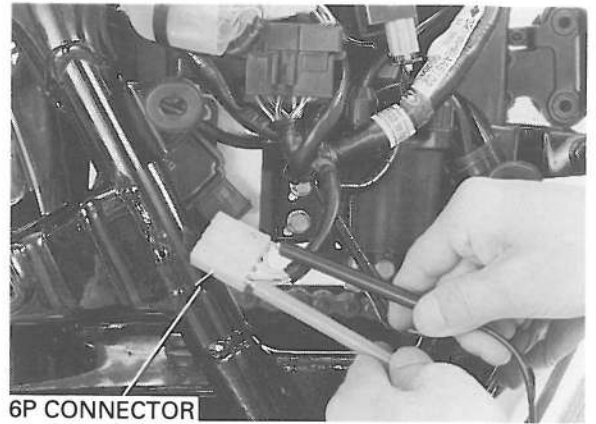

CHARGING LINE

It is not necessary to remove the stator coil to complete this test.

Measure the resistance between the connector terminals and ground.

CONNECTION: Yellow and Yellow
STANDARD: 0.1 – 0.3 Ω (20 °C/68 °F)

If the charging coil reading is out of specification, replace the stator (page 9-2).

Check for continuity between the connector terminals and ground.
There should be no continuity.

If there is continuity between the connector and ground, replace the stator (page 9-2).

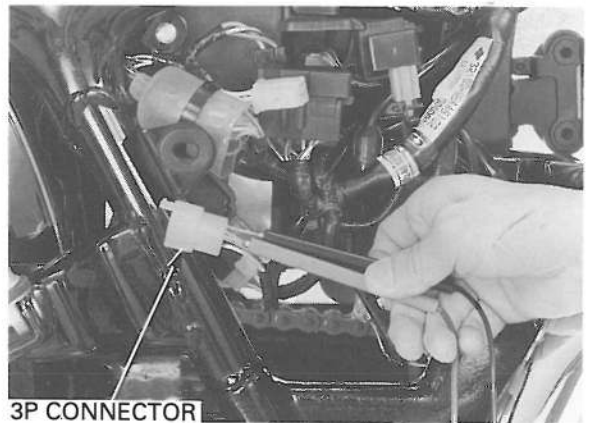

BATTERY/CHARGING SYSTEM

REMOVAL/INSTALLATION

Remove the left side cover (page 2-4).

Disconnect the regulator/rectifier 6P connector.



Remove the nuts and regulator/rectifier unit.

Installation is in the reverse order of removal.

NOTE:

Route the wire harness properly (page 1-22).

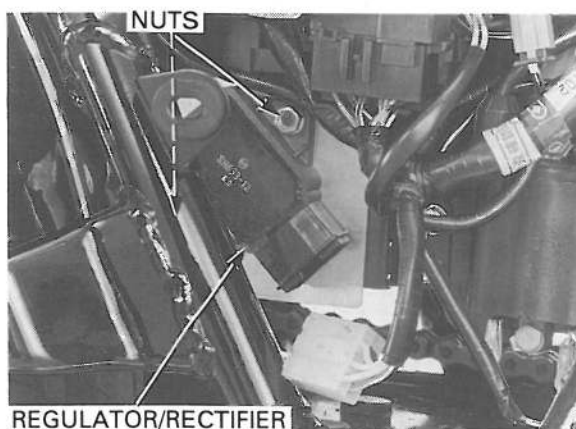

MEMO

IGNITION SYSTEM

SYSTEM DIAGRAM

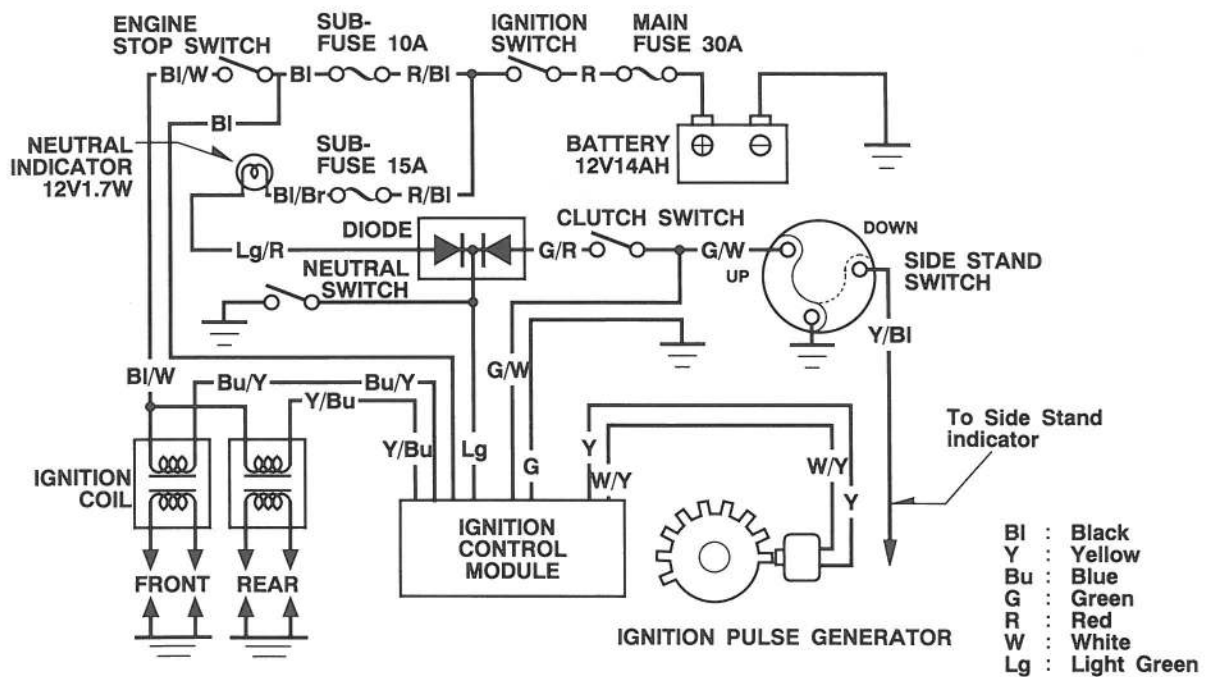
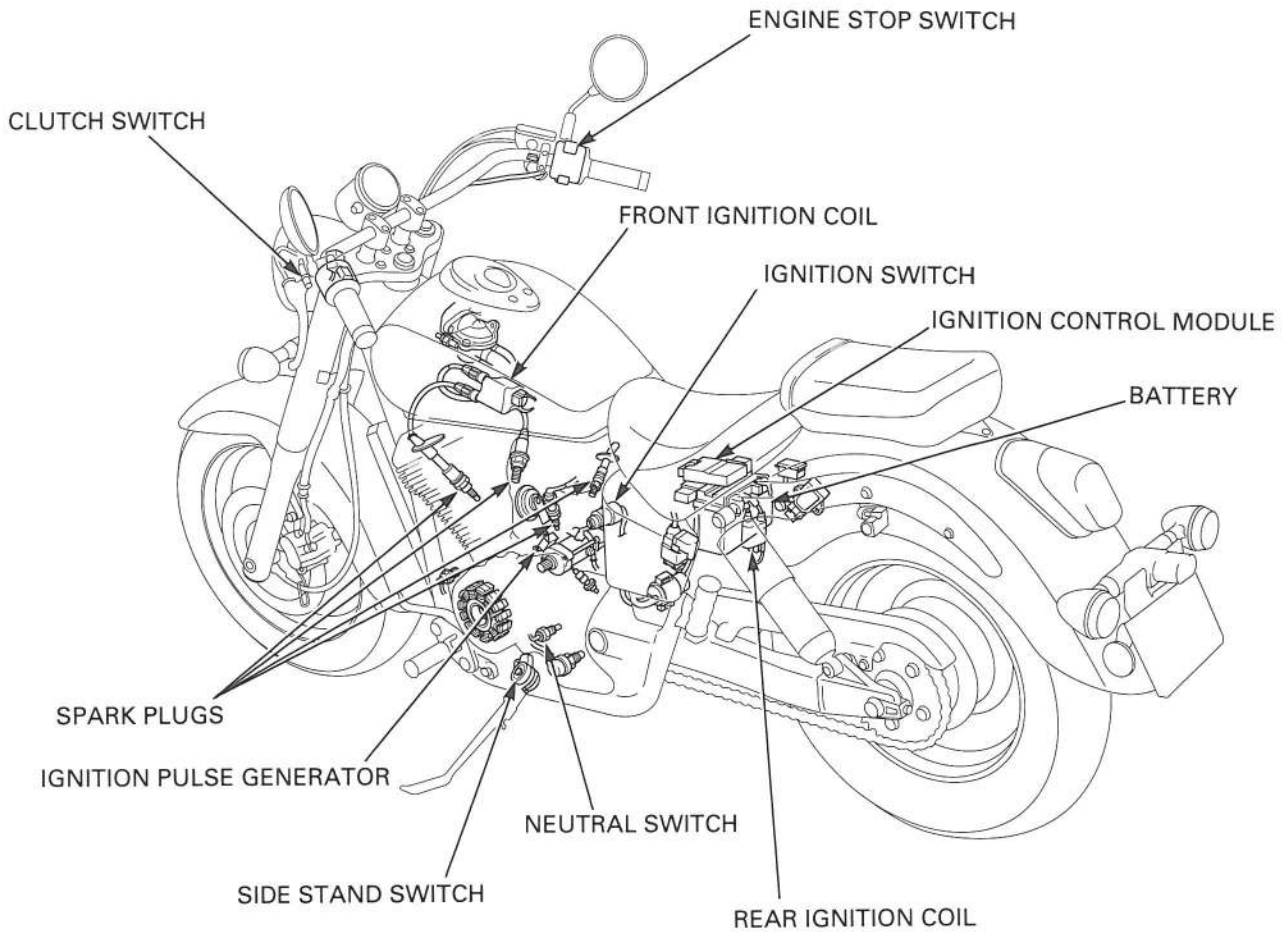

17. IGNITION SYSTEM

SYSTEM DIAGRAM	17-0	IGNITION CONTROL MODULE (ICM)	17-7
SERVICE INFORMATION	17-1	IGNITION COIL	17-7
TROUBLESHOOTING	17-3	IGNITION TIMING	17-8
IGNITION SYSTEM INSPECTION	17-4		

SERVICE INFORMATION

GENERAL

⚠ WARNING

If the engine must be running to do some work, make sure the area is well-ventilated. Never run the engine in an enclosed area. The exhaust contains poisonous carbon monoxide gas that may cause loss of the consciousness and may lead to death. Run the engine in an open area or with an exhaust evacuation system in an enclosed area.

CAUTION:

Some electrical components may be damaged if terminals or connectors are connected or disconnected while the ignition switch is ON and a current is present.

- When checking the ignition system, always follow the steps in the troubleshooting (page 17-3).
- Ignition timing cannot be adjusted since the Ignition Control Module (ICM) is non-adjustable. If ignition timing is incorrect, check the system components and replace any faulty parts.
- The ICM may be damaged if dropped. Also, if the connector is disconnected when current is flowing, the resulting excessive voltage may damage the unit. Always turn off the ignition switch before servicing.
- A faulty ignition system is often related to poorly connected or corroded connectors. Check those connections before proceeding. Make sure the battery is adequately charged. Using the starter motor with a weak battery results in a slower engine cranking speed as well as no spark at the spark plugs.
- Use spark plugs of the correct heat range. Using a spark plug of an incorrect heat range can damage the engine.
- For neutral switch and side stand switch inspection and removal/installation see section 19.
- For engine stop switch and ignition switch inspection and removal/installation see section 13, 19.

SPECIFICATIONS

ITEM		SPECIFICATIONS	
Spark plug		NGK	DENSO
	Standard	DPR8EA 9	X24EPR-U9
	For cold climate (below 5°C/41°F)	DPR7EA 9	X22EPR-U9
	For extended high speed riding	DPR9EA 9	X27EPR-U9
Spark plug gap	0.80 – 0.90 mm (0.031 – 0.035 in)		
Ignition coil primary peak voltage	100 V minimum		
Ignition pulse generator peak voltage	0.7 V minimum		
Ignition timing "F" mark	8° BTDC at 1,000 rpm		
Advance	Start	3,000 ± 200 rpm	
	Stop	5,500 ± 200 rpm	
Full advance	24.5° BTDC at 5,500 rpm		

IGNITION SYSTEM

TORQUE VALUES

Timing hole cap

10 N•m (1.0 kgf•m, 7 lbf•ft)

Apply grease to the threads

TOOLS

Imrie diagnostic tester (model 625) or
Peak voltage adapter

07HGJ-020100 with
Commercially available digital multimeter
(impedance 10 M Ω /DCV minimum)

TROUBLESHOOTING

- Inspect the following before diagnosing the system.
 - Faulty spark plug
 - Loose spark plug cap or spark plug wire connections
 - Water got into the spark plug cap (Leaking to the ignition coil secondary voltage)
- If there is no spark at either cylinders, temporarily exchange the ignition coil with the other good one and perform the spark test. If there is a spark, the exchanged ignition coil is faulty.
- “Initial voltage” of the ignition primary coil is the battery voltage with the ignition switch ON and engine stop switch at RUN (The engine is not cranked by the starter motor).

No spark at all plugs

Unit: mm (in)

Unusual condition		Probable cause (Check in numerical order)
Ignition coil primary voltage	No initial voltage with ignition and engine stop switches ON. (Other electrical components are normal.)	<ol style="list-style-type: none"> 1. Faulty engine stop switch. 2. An open circuit in Black/White wire between the ignition coil and engine stop switch. 3. Loose primary terminal or an open circuit in primary coil. 4. Faulty ICM (when the initial voltage is normal while disconnecting ICM connectors).
	Initial voltage is normal, but it drops down to 2 – 4 V while cranking the engine.	<ol style="list-style-type: none"> 1. Incorrect peak voltage adapter connections. 2. Undercharged battery. 3. No voltage between the Black/White (+) and Body ground (-) at the ICM connector or loosen ICM connection. 4. An open circuit or loose connection in Green wire. 5. An open circuit or loose connection in Yellow/Blue and Blue/Yellow wires between the ignition coils and ICM. 6. Short circuit in ignition primary coil. 7. Faulty side stand switch or neutral switch. 8. An open circuit or loose connection in No.7 related circuit wires. <ul style="list-style-type: none"> • Side stand switch line: Green/White wire. • Neutral switch line: Light green/Red wire. 9. Faulty ignition pulse generator (measure the peak voltage). 10. Faulty ICM (in case when above No. 1 – 9 are normal).
	Initial voltage is normal, but no peak voltage while cranking the engine.	<ol style="list-style-type: none"> 1. Faulty peak voltage adapter connections. 2. Faulty peak voltage adapter. 3. Faulty ICM (in case when above No.1, 2 are normal).
	Initial voltage is normal, but peak voltage is lower than standard value.	<ol style="list-style-type: none"> 1. The multimeter impedance is too low; below 10 MΩ/DCV. 2. Cranking speed is too low (battery undercharged). 3. The sampling timing of the tester and measured pulse were not synchronized (system is normal if measured voltage is over the standard voltage at least once). 4. Faulty ICM (in case when above No. 1 – 3 are normal).
	Initial and voltage are normal, but does not spark.	<ol style="list-style-type: none"> 1. Faulty spark plug or leaking ignition coil secondary current ampere. 2. Faulty ignition coil.
Ignition pulse generator	Peak voltage is lower than standard value.	<ol style="list-style-type: none"> 1. The multimeter impedance is too low; below 10 MΩ/DCV. 2. Cranking speed is too low (battery undercharged). 3. The sampling timing of the tester and measured pulse were not synchronized (system is normal if measured voltage is over the standard voltage at least once). 4. Faulty ignition pulse generator (in case when above No. 1 – 3 are normal).
	No peak voltage.	<ol style="list-style-type: none"> 1. Faulty peak voltage adapter. 2. Faulty ignition pulse generator.

IGNITION SYSTEM INSPECTION

NOTE:

- If there is no spark at either plug, check all connections for loose or poor contact before measuring each peak voltage.
- Use the recommended digital multimeter or commercially available digital multimeter with an impedance of 10 M Ω /DCV minimum.
- The display value differs depending upon the internal impedance of the multimeter.
- If using an Imrie diagnostic tester (model 625), follow the manufacturer's instructions.

Connect the peak voltage adapter to the digital multimeter, or use the Imrie diagnostic tester.

TOOLS:

**Imrie diagnostic tester (model 625) or
Peak voltage adaptor 07HGJ – 0020100 with
Commercially available digital multimeter
(impedance 10M Ω /DCV minimum)**

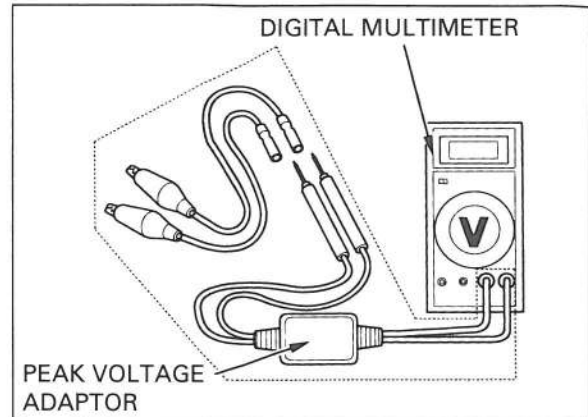

IGNITION PRIMARY VOLTAGE INSPECTION

NOTE:

- Check all system connection before the inspection. If the system is disconnected, an incorrect peak voltage will register.
- Check cylinder compression at each cylinder and check that the spark plugs are installed correctly in each cylinder.

Support the motorcycle using the side stand.

Disconnect the spark plug caps from the spark plugs on the cylinder head (page 17-7).

Connect a good known spark plug to each spark plug cap and ground the spark plugs to the cylinder as done in a spark test.

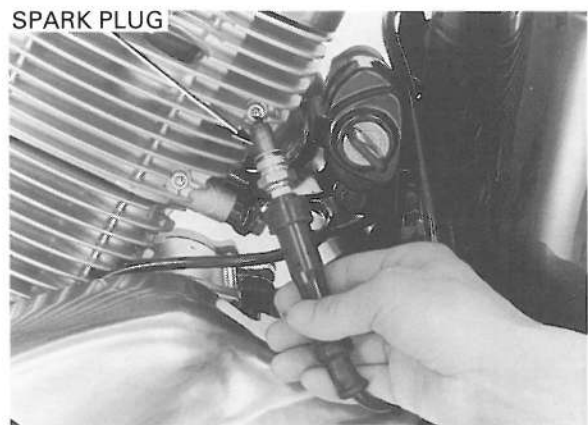

When servicing the front ignition coil:

- Remove the fuel tank (page 2-4).

When servicing the rear ignition coil:

- Remove the right side cover (page 2-4).

*Do not disconnect
the ignition coil
primary wires.*

Connect the peak voltage adaptor or Imrie tester to the ignition coil primary terminal.

TOOLS:

**Imrie diagnostic tester (model 625) or
Peak voltage adapter 07HGJ - 0020100 with
Commercially available digital multimeter
(impedance 10M Ω /DCV minimum)**

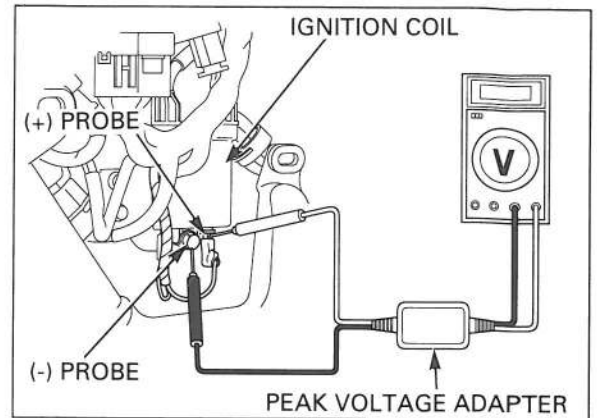

CONNECTION:

Front ignition coil:

Blue/Yellow (+) - Body ground (-)

Rear ignition coil:

Yellow/Blue (+) - Body ground (-)

⚠ WARNING

Avoid touching the spark plugs and tester probes to prevent electric shock.

Turn the ignition switch "ON" and engine stop switch to "RUN".

Check for initial battery voltage.

If battery voltage is not present, follow the checks described in the troubleshooting on page 17-3.

Shift the transmission into neutral.

Crank the engine with the starter motor and read each ignition coil primary voltage.

PEAK VOLTAGE: 100 V minimum

NOTE:

Although measured values are different for each ignition coil, they are normal as long as the voltage is higher than the standard value.

If the peak voltage is lower than the standard value, follow the checks described in the troubleshooting on page 17-3.

IGNITION PULSE GENERATOR PEAK VOLTAGE INSPECTION

NOTE:

- Check all system connections before the inspection. If the system is disconnected, an incorrect peak voltage will register.
- Check cylinder compression at each cylinder and check that the spark plugs are installed correctly in each cylinder.

Remove the ignition control module (ICM) (page 17-7).

Disconnect the ignition control module (ICM) 16P connector.

Connect the peak voltage adaptor to the 16P connector wire harness side.

TOOLS:

Imrie diagnostic tester (model 625) or Peak voltage adapter 07HGJ – 0020100 with Commercially available digital multimeter (impedance 10M Ω /DCV minimum)

CONNECTION: White/Yellow (+) – Yellow (-)

Turn the ignition switch "ON" and engine stop switch to "RUN".

Shift the transmission into neutral.

Crank the engine with the starter motor and read the ignition pulse generator peak voltage.

PEAK VOLTAGE: 0.7 V minimum

If the peak voltage is lower than standard value, perform the following procedure.

Remove the steering covers (page 2-3).

Disconnect the ignition pulse generator 2P (White) connector.

Turn the ignition switch "ON" and engine stop switch to "RUN".

Shift the transmission into neutral.

Crank the engine with the starter motor and measure the peak voltage at the 2P (White) connector ignition pulse generator side and record it.

CONNECTION: White/Yellow (+) – Yellow (-)

PEAK VOLTAGE: 0.7 V minimum

Compare their values at the ignition control module (ICM) 16P connector and the ignition pulse generator 2P connector.

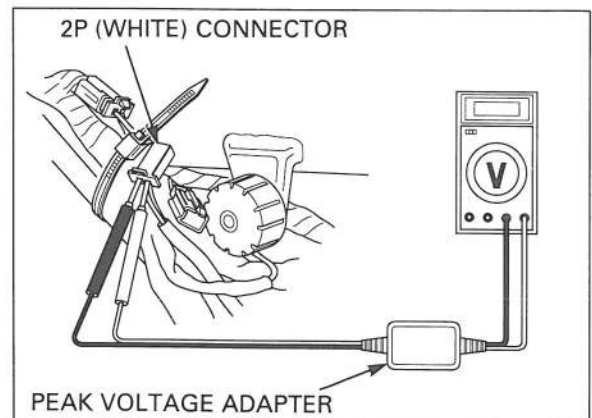
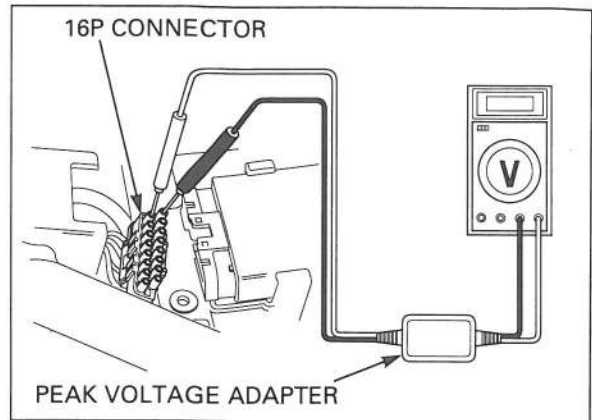

If the value at the ignition pulse generator is normal, but abnormal at the ignition control module (ICM):

- Open circuit in the ignition pulse generator wires
- Loosen connection in the ignition pulse generator connector

If both values are abnormal:

- The ignition pulse generator is likely to be faulty. Check and perform troubleshooting on page 17-3.
- For ignition pulse generator replacement, refer to section 8.

IGNITION CONTROL MODULE (ICM)

REMOVAL/INSTALLATION

Remove the seat (page 2-2).

Remove the ignition control module (ICM) from the battery case cover.

Disconnect the 16P connector.

Installation is in the reverse order of removal.

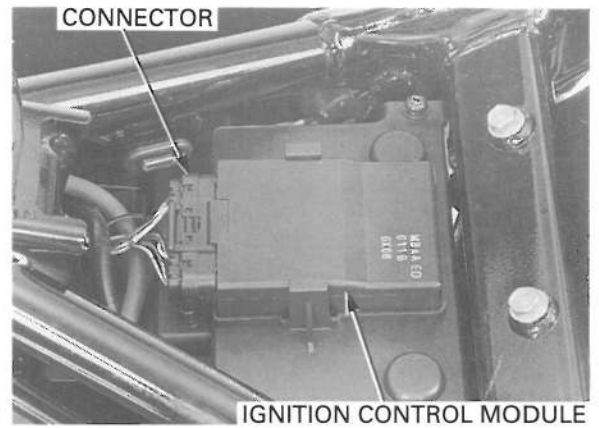

IGNITION COIL

REMOVAL/INSTALLATION

FRONT:

Disconnect the spark plug caps from the spark plugs.

Remove the fuel tank (page 2-4).

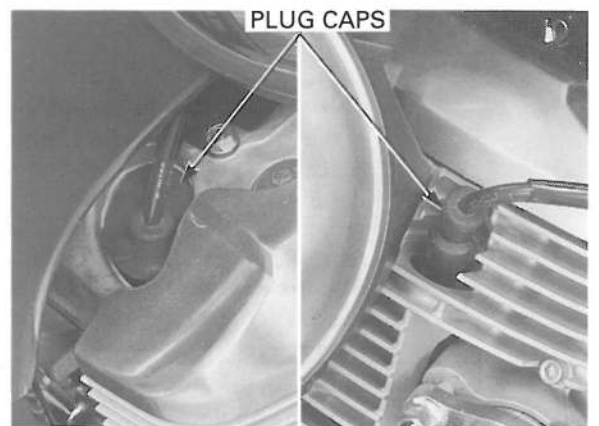

Disconnect the ignition coil primary wires from the terminals.

Remove the bolts and ignition coil.

Installation is in the reverse order of removal.

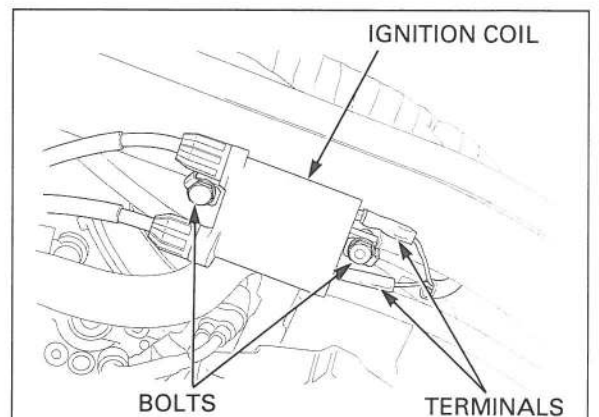

IGNITION SYSTEM

REAR:

Remove the right side cover (page 2-4).

Disconnect the spark plug caps from the spark plugs.
Disconnect the ignition coil primary wires from the terminals.

Remove the bolts and ignition coil.

Installation is in the reverse order of removal.

NOTE:

- Route the spark plug wires properly (Section 1).
- Connect the primary wires to the original position.

Front:

Black terminal: Black/White wire

Green terminal: Blue/Yellow wire

Rear:

Black terminal: Black/White wire

Green terminal: Yellow/Blue wire

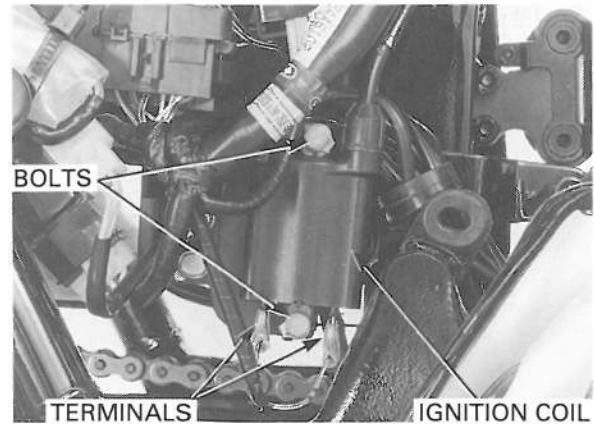
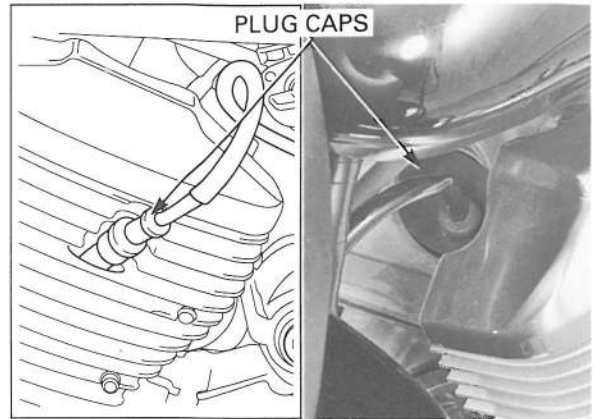

IGNITION TIMING

⚠ WARNING

If the engine must be running to do some work, make sure the area is well-ventilated. Never run the engine in an enclosed area. The exhaust contains poisonous carbon monoxide gas that may cause loss of the consciousness and lead to death.

Run the engine in an open area or with an exhaust evacuation system in an enclosed area.

Read the manufacturer's instructions for the timing light before operating.

Warm up the engine.

Stop the engine.

Remove the timing hole cap.

Connect a timing light to the rear (No.1) cylinder spark plug wire.

Start the engine and let it idle.

IDLE SPEED: 1,000 ± 100 rpm

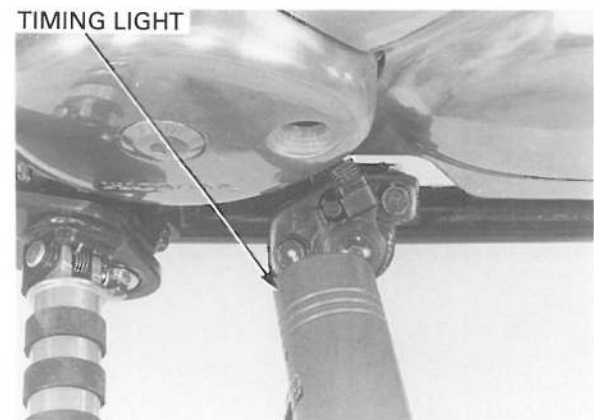
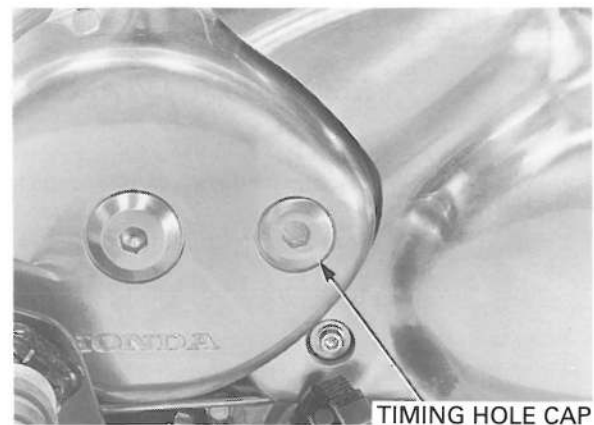

The timing is correct if the "F" mark on the flywheel aligns with the index mark on the left crankcase cover.



Increase the engine speed by rotating the throttle stop control knob. The timing is correct if the advance marks on the flywheel align with the index mark on the left crankcase cover.



Stop the engine and connect the timing light to the front (No.2) cylinder spark plug wire.

Recheck the ignition timing at the front cylinder. Coat the new O-ring with engine oil and install it in the timing hole cap groove. Apply grease to the timing hole cap threads and flange surface.

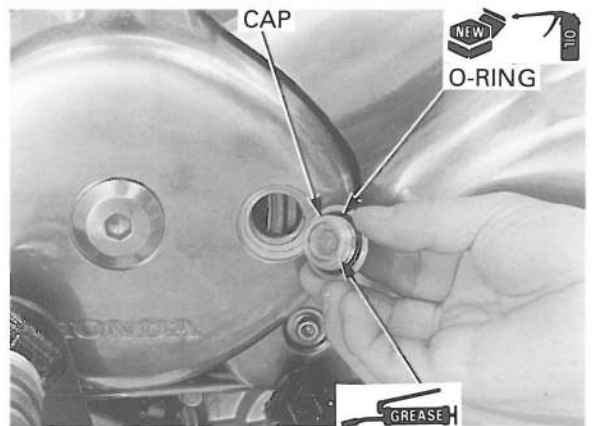

Install and tighten the timing hole cap to the specified torque.

TORQUE: 10 N·m (1.0 kgf·m, 7 lbf·ft)

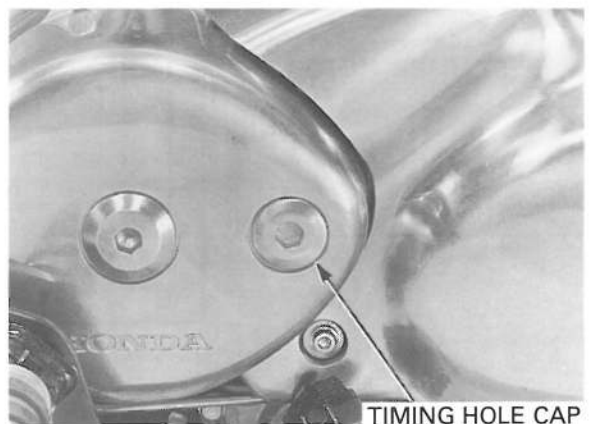

ELECTRIC STARTER

SYSTEM DIAGRAM

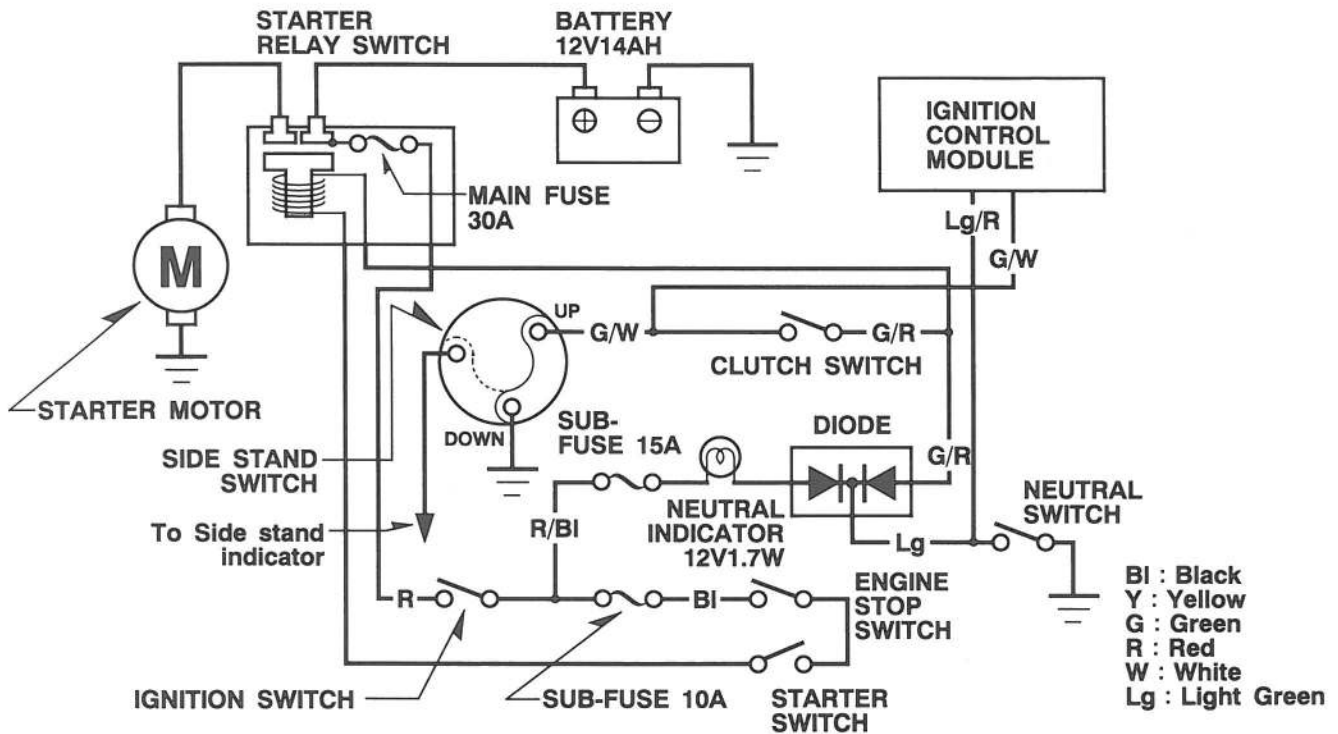
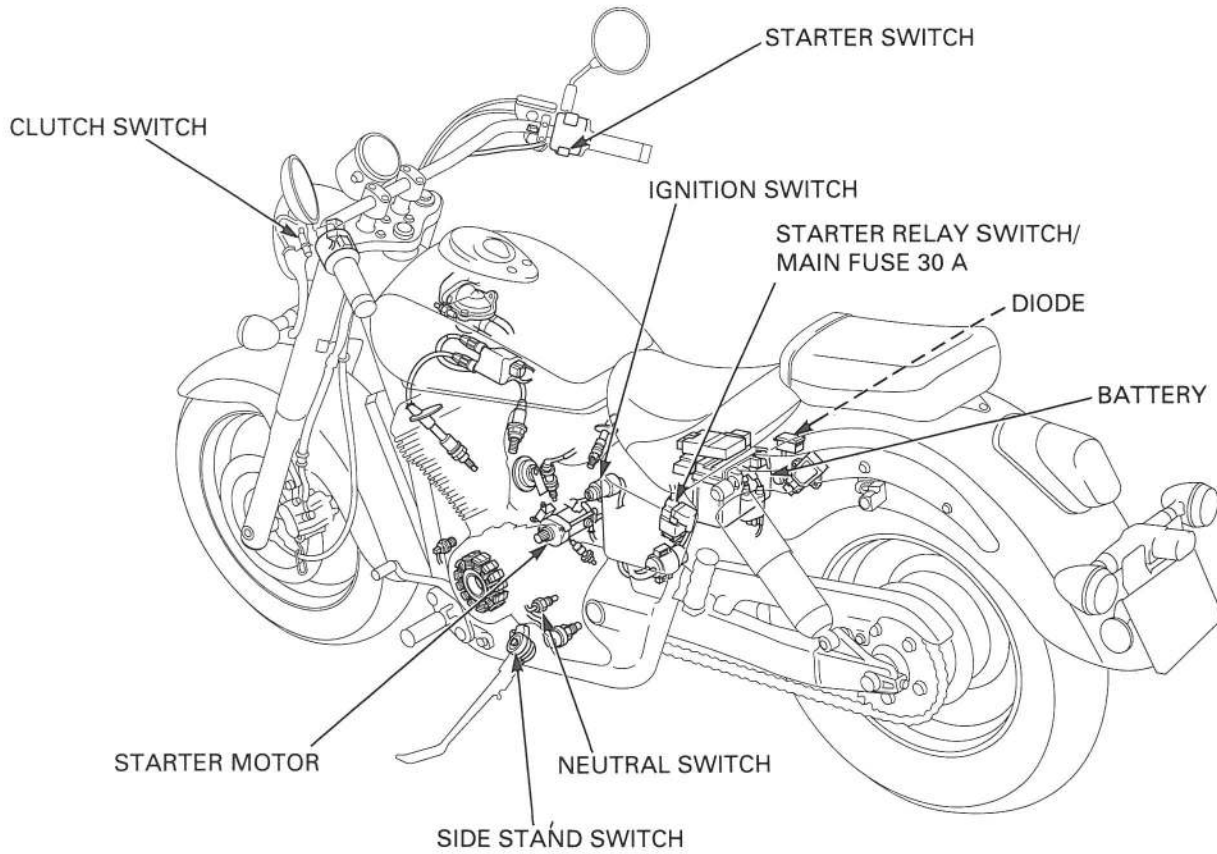

18. ELECTRIC STARTER

SYSTEM DIAGRAM	18-0	STARTER MOTOR	18-4
SERVICE INFORMATION	18-1	STARTER RELAY SWITCH	18-13
TROUBLESHOOTING	18-2	CLUTCH DIODE	18-14

SERVICE INFORMATION

GENERAL

WARNING

Always turn the ignition switch OFF before servicing the starter motor. The motor could suddenly start, causing serious injury.

- When checking the starter system, always follow the steps in the troubleshooting flow chart (page 18-2).
- A weak battery may be unable to turn the starter motor quickly enough, or supply adequate ignition current.
- If current continues to flow kept flowing through the starter motor while the engine is not cranking over, the starter motor may be damaged.
- Always turn of the ignition switch before disconnecting any electrical components.
- For following components inspections, refer to the following pages, for the parts locations, see page 18-0 of this manual.
 - Side stand switch (Section 19)
 - Neutral switch (Section 19)
 - Ignition switch (Section 19)
 - Starter switch (Section 19)
 - Clutch switch (Section 19)

SPECIFICATIONS

Unit: mm (in)

ITEM	STANDARD	SERVICE LIMIT
Starter motor brush length	12.5 (0.49)	6.5 (0.26)

TORQUE VALUES

Starter motor cable nut 10 N•m (1.0 kgf•m, 7 lbf•ft)

ELECTRIC STARTER

TROUBLESHOOTING

- Check for the following before troubleshooting the system.
 - Blown main fuse (30 A) or sub-fuse (10 A, 15 A).
 - Loose battery and starter motor cable.
 - Discharged battery.
- The starter motor should turn when the transmission is in neutral
- The starter motor should turn when transmission is in any gear as indicated the chart below.

Gear Position	Side Stand	Clutch Lever	Starter Motor
Any Gear	Up	Pulled in	Turn
		Released	Does not turn
	Down	Pulled in	Does not turn
		Released	Does not turn

Starter motor will not turn

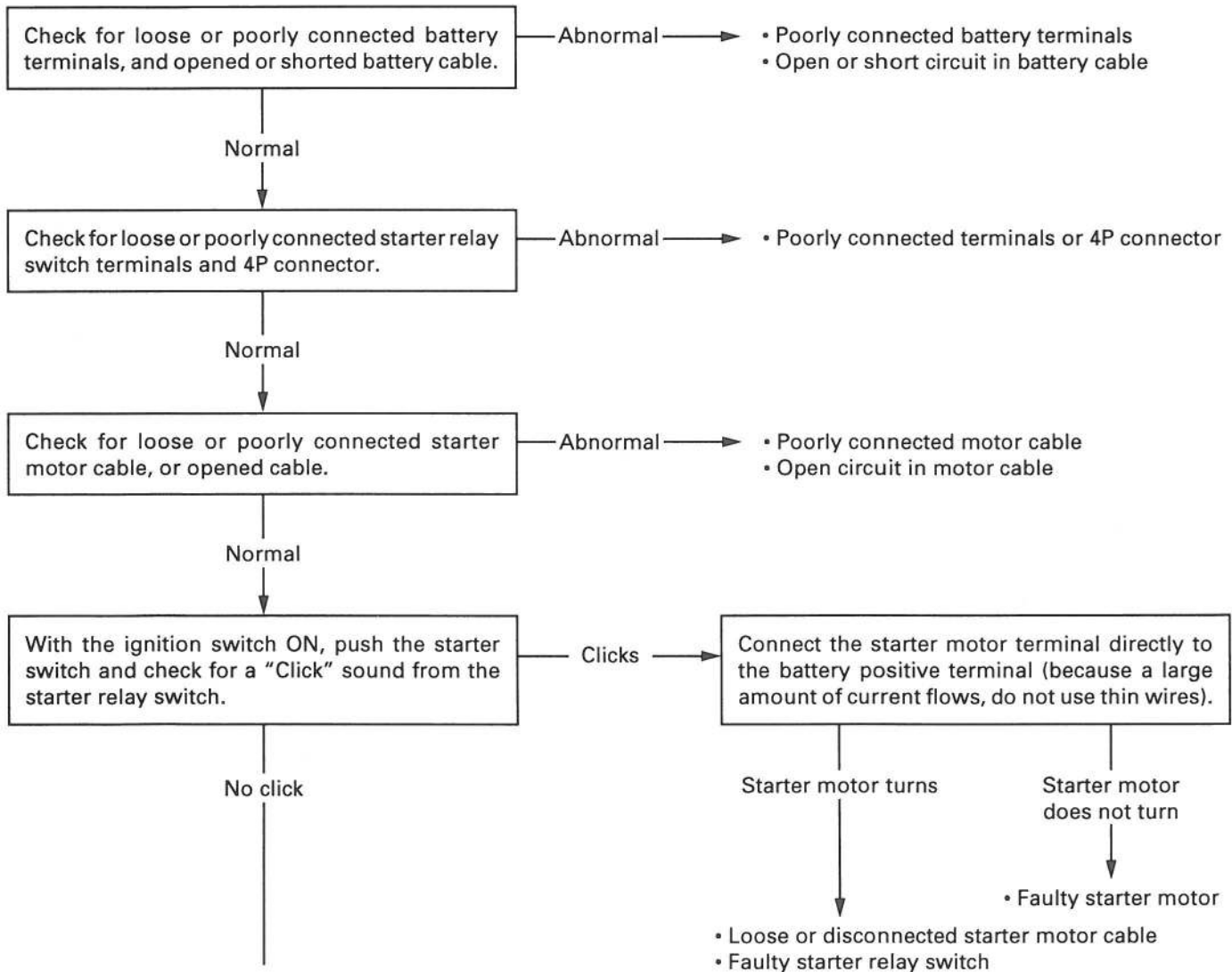

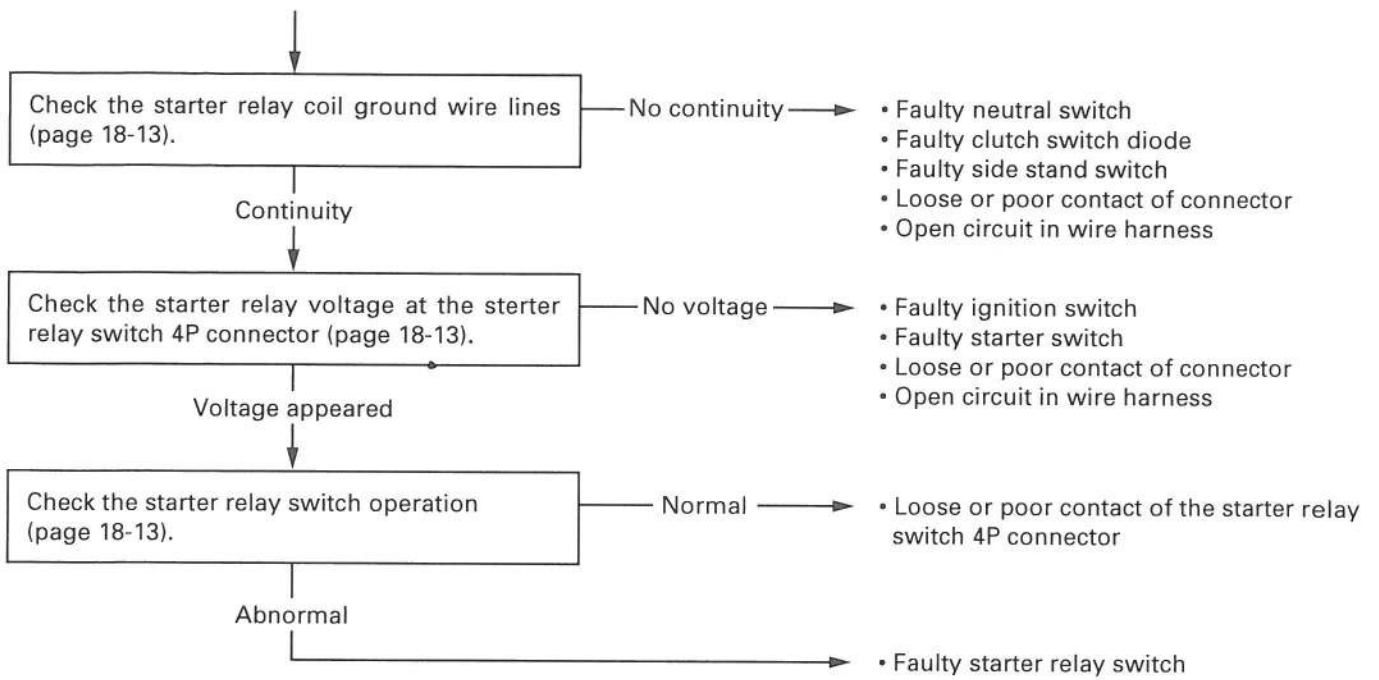

The starter motor turns when the transmission is in neutral, but does not turn with the transmission in any position except neutral. The side stand is up and the clutch lever is pulled in.

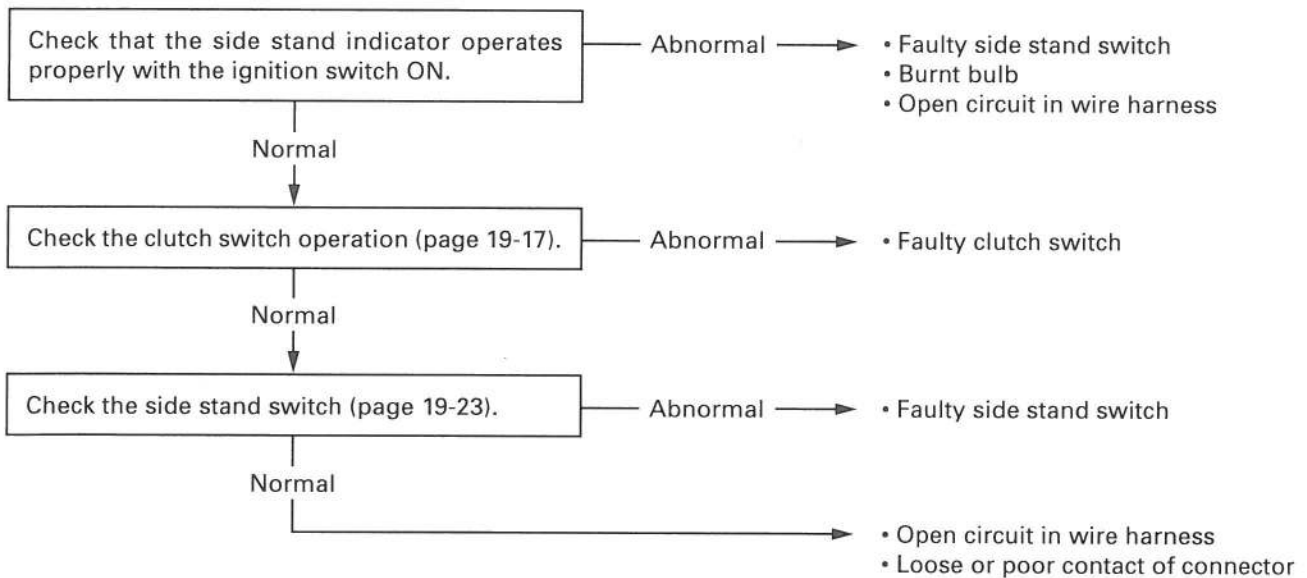

Starter motor turns slowly

- Poorly connected battery terminal cable
- Poorly connected starter motor cable
- Faulty starter motor
- Worn or damaged starter motor brush
- Low battery

Starter relay switch "clicks", but engine does not turn over

- Crankshaft does not turn due to engine problem
- Faulty starter reduction gear
- Faulty starter idle gear
- Low battery

Starter motor turns, but engine does not turn

- Starter motor is running backwards
 - Case assembled improperly
 - Terminals connected improperly
- Faulty starter clutch

STARTER MOTOR

REMOVAL

⚠ WARNING

Always turn the ignition switch OFF before servicing the starter motor. The motor could suddenly start, causing serious injury.

Remove the rubber cap and starter motor cable nut. Disconnect the starter motor cable.

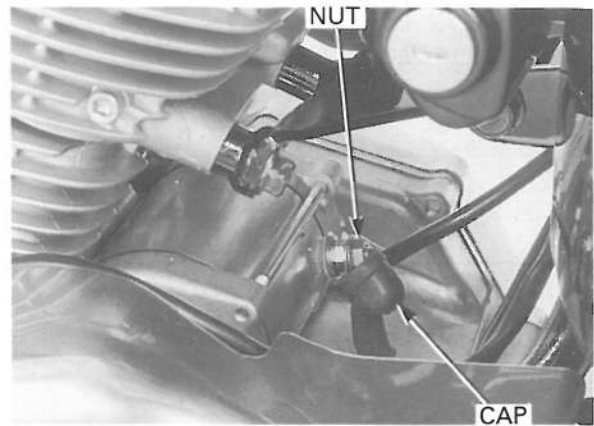

Remove the bolts and ground cable. Remove the starter motor from the left side.

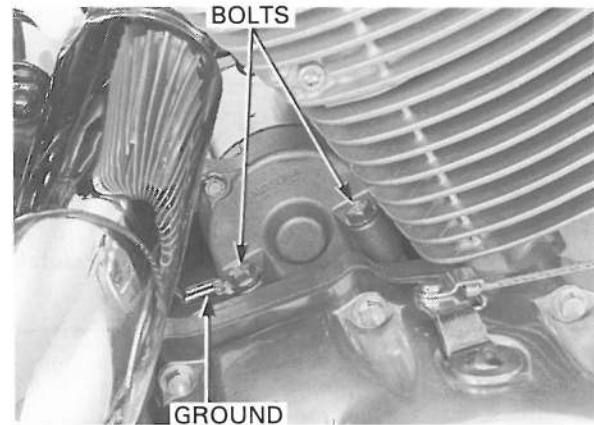

Remove the O-ring.

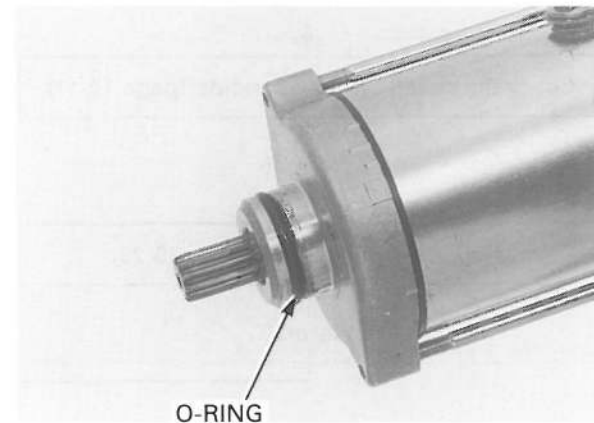

DISASSEMBLY

NOTE:

Record the location and number of shims and washers.

Remove the bolts, rear cover and O-ring.

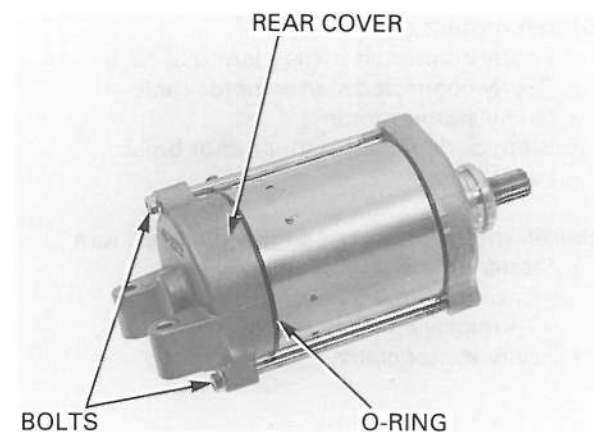

Remove the thrust washers.



Remove the front cover and O-ring.

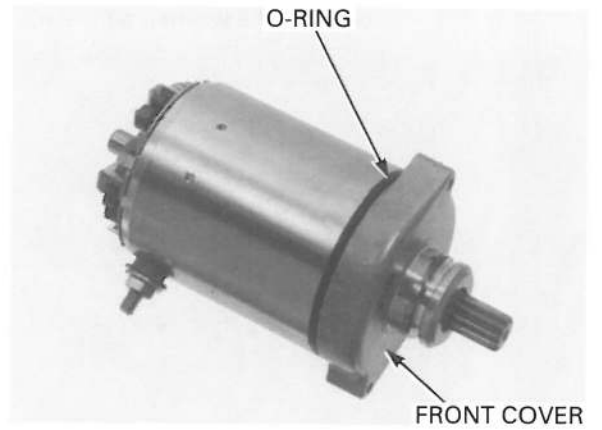

Remove the thrust washers.

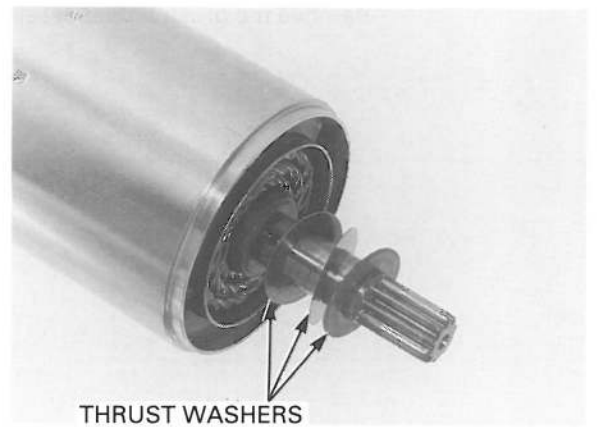

Remove the armature.

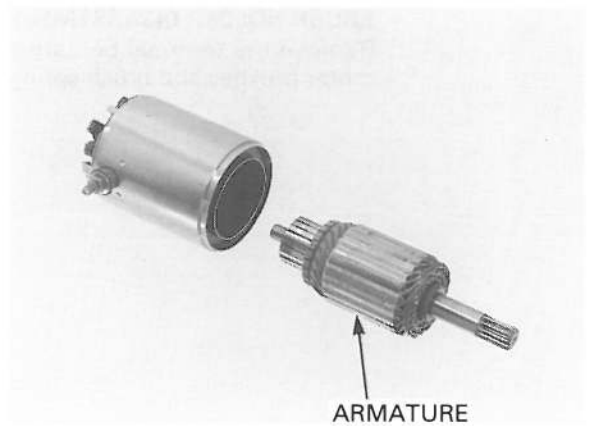

ELECTRIC STARTER

Remove the terminal nut.

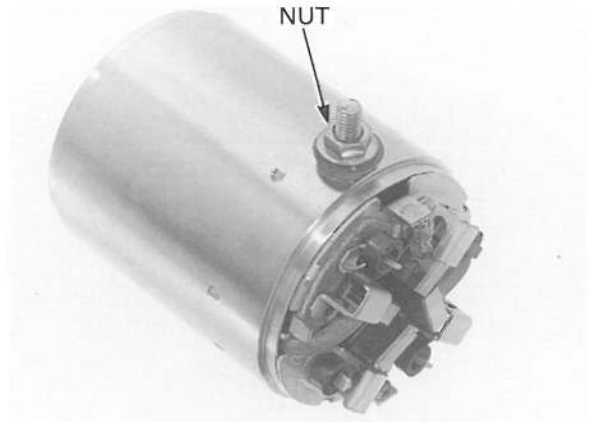

Remove the washer, shims and O-ring.

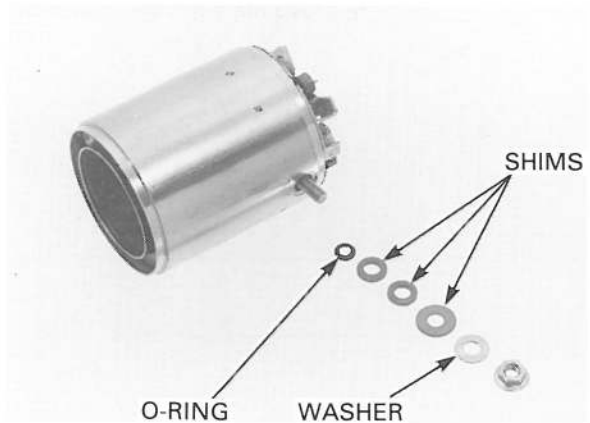

Remove the brush holder assembly.

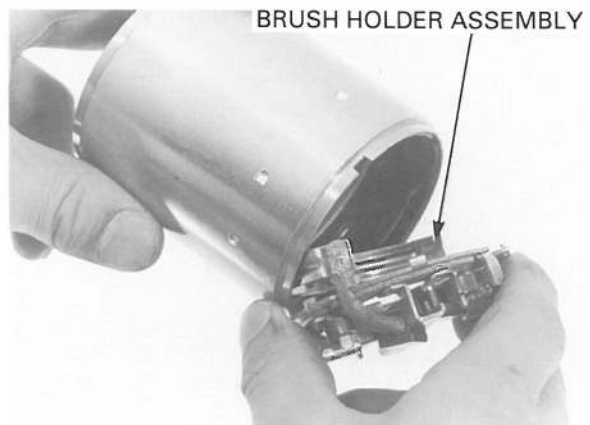

BRUSH HOLDER DISASSEMBLY

Remove the terminal bolt stopper, terminal bolt, motor brushes and brush springs.

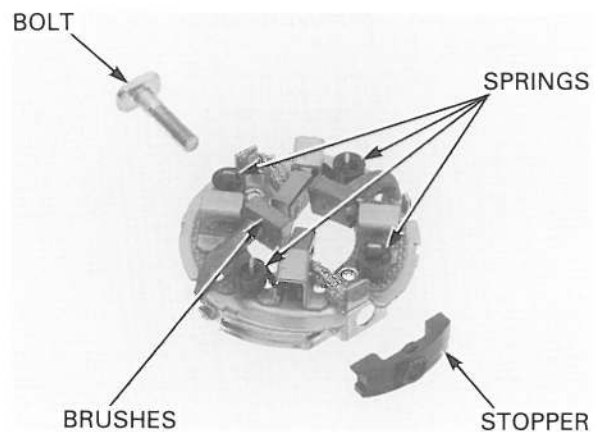

INSPECTION

Measure the each brush length

SERVICE LIMIT: 6.5 mm (0.26 in)

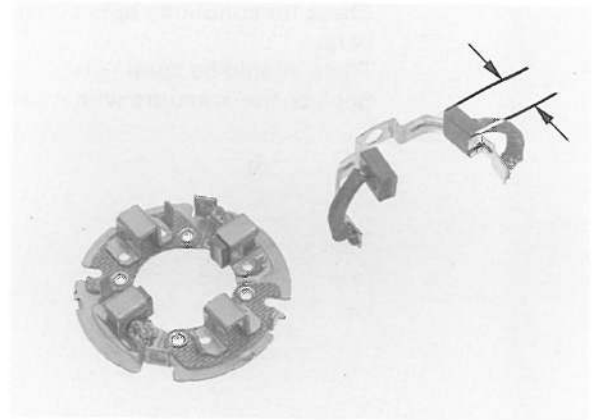

Check for continuity between starter motor terminal and positive brush.

There should be continuity.

Check for continuity between starter motor terminal and starter motor case.

There should be no continuity.

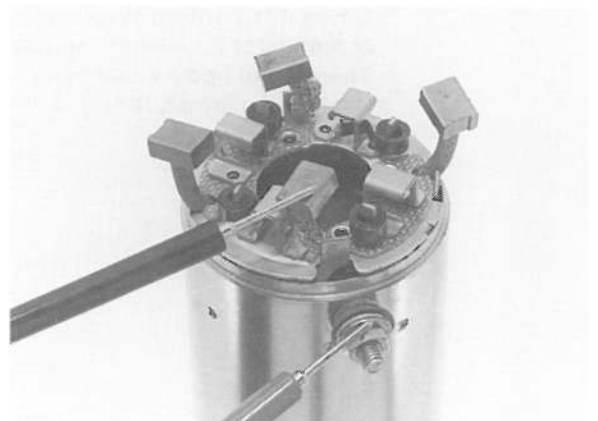

Check for continuity between positive and negative terminals.

There should be no continuity.

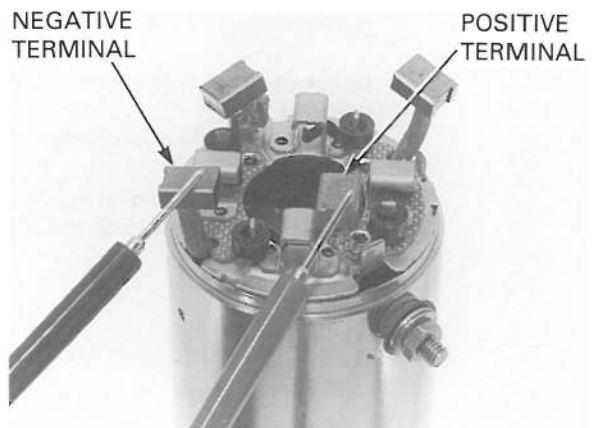

Check the commutator for damage or abnormal wear.

Replace the armature with a new one if necessary.

Check the commutator for metallic debris between commutator bars.

Clean the metallic debris off between commutator bars.

Check the commutator for discoloration of the commutator bar.

Replace the armature with a new one if necessary.

Do not use emery or sand paper on the commutator.

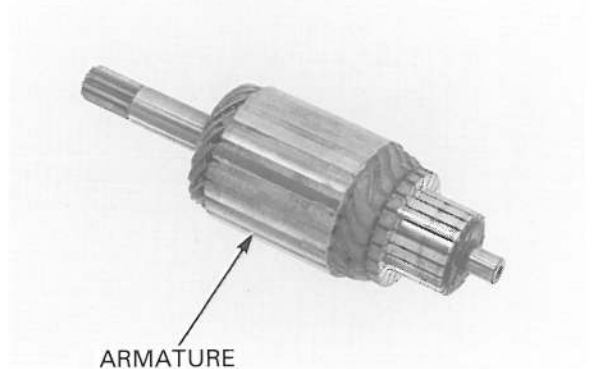

ELECTRIC STARTER

Check for continuity between pairs of commutator bars.
There should be continuity.
Replace the armature with a new one if necessary.

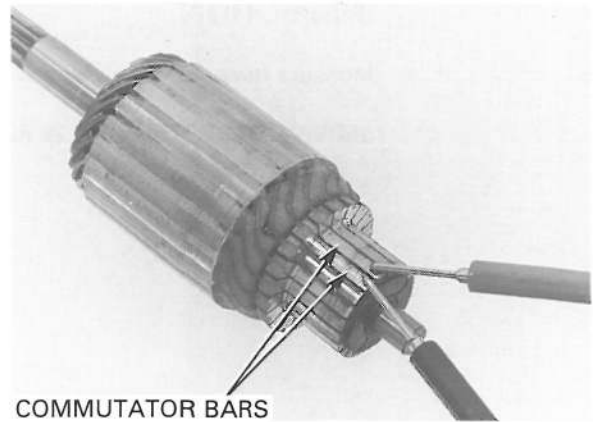

Check for continuity between each individual commutator bar and the armature shaft.
There should be no continuity.
Replace the armature with a new one if necessary.

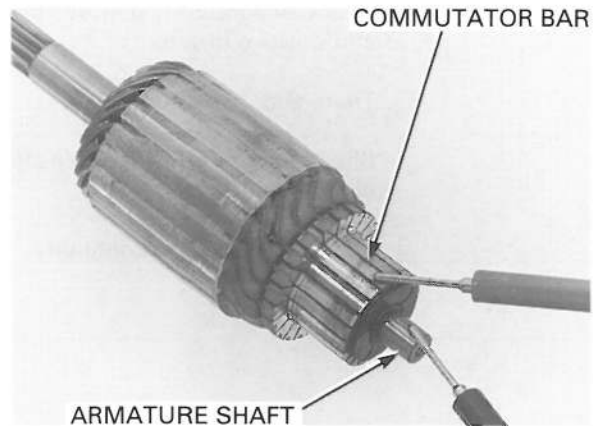

Remove the lock washer from the front cover.

Check the dust seal and needle bearing for wear or damage.
Check the needle bearing rotates smoothly.

Apply grease to the seal lips and needle bearing.
Install the lock washer to the front cover.

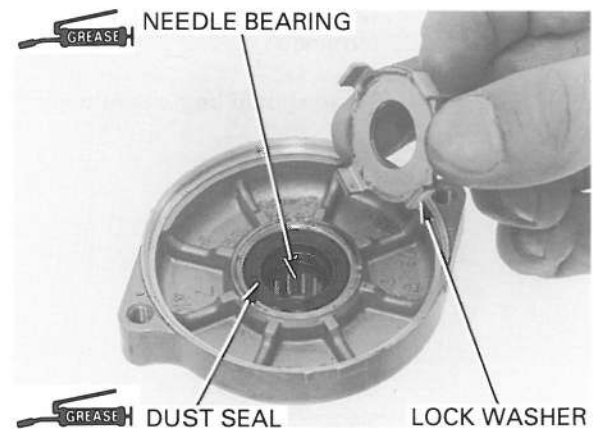

ASSEMBLY

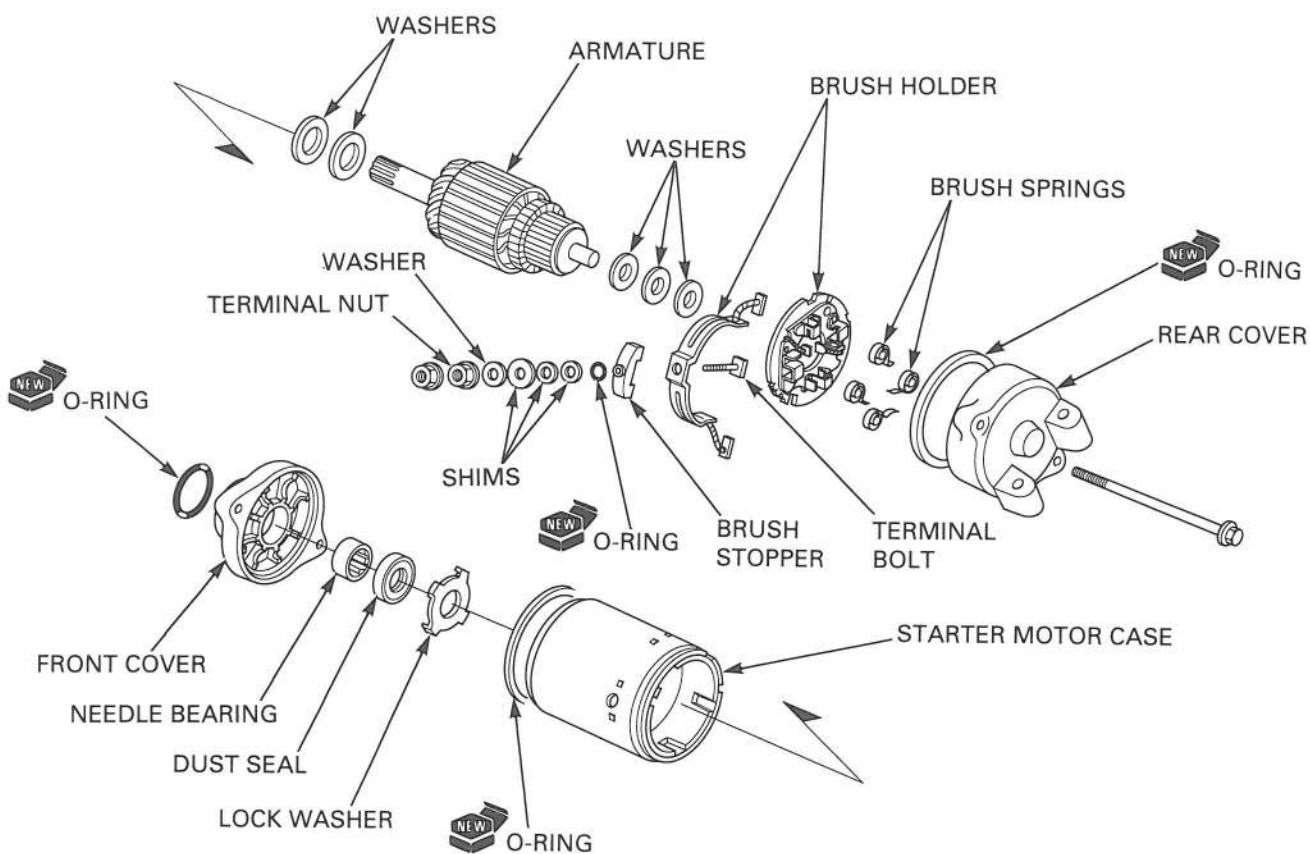

BRUSH HOLDER ASSEMBLY

Install the brush spring, motor brush and terminal bolt.

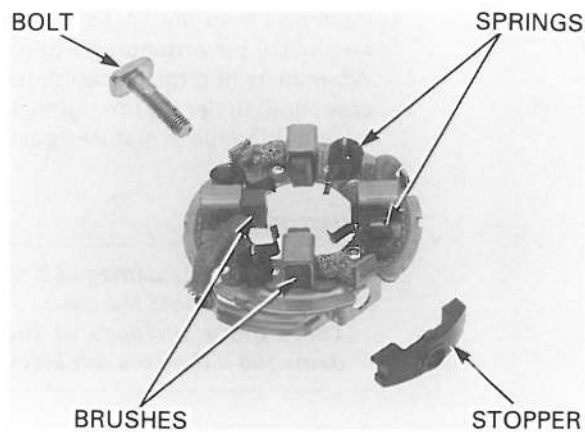

Install the terminal bolt stopper with its tab side facing to the rear cover side.

Install the terminal bolt and brush holder to the starter motor case aligning the terminal bolt and hole on the starter motor case.

Align the starter motor case notch with the brush holder tab.

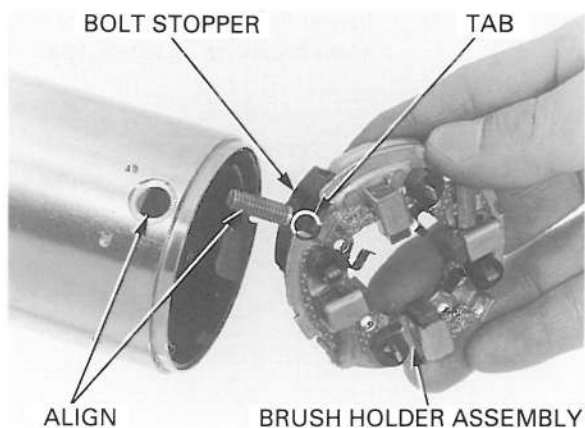

ELECTRIC STARTER

Install the new O-ring.
Install the same number of shims in the same locations as when disassembled.
Install the washer and terminal nut.

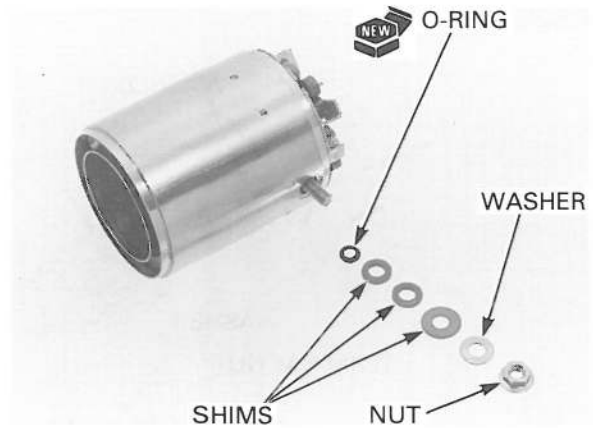

Tighten the terminal nut securely.

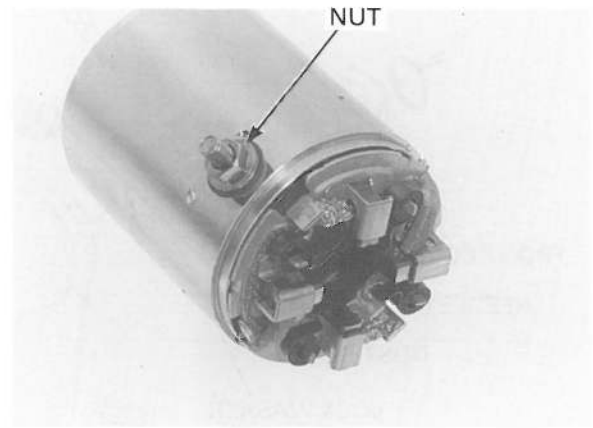

Push and hold the brush inside the brush holder, and install the armature through the brush holder. When installing the armature into the stator motor case, hold the armature tightly to keep the magnet from pulling the armature against the stator motor case.

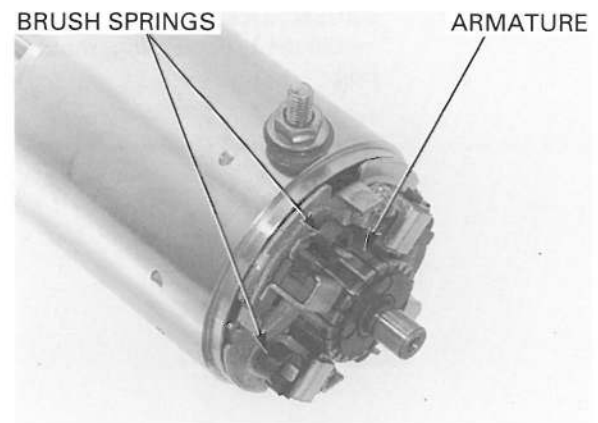

CAUTION:

- *The coil may be damaged if the magnet pulls the armature against the case.*
- *The sliding surfaces of the brushes can be damaged if they are not installed properly.*

Set the brush springs.

Install the same number of thrust washers in the same locations as when disassembled.

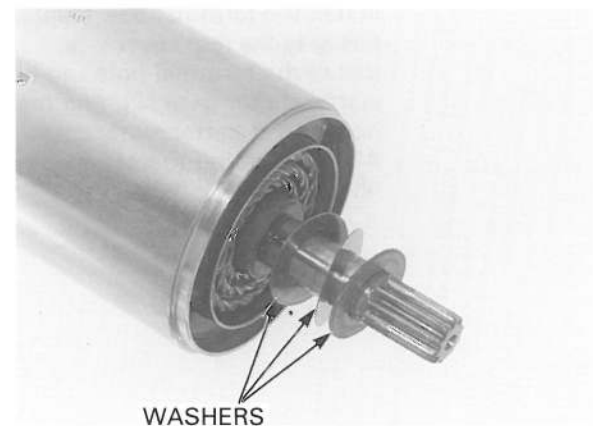

Install the new O-ring and front cover with aligning the index mark.

CAUTION:

When installing the front cover, take care to prevent damaging the oil seal lip with the armature shaft.

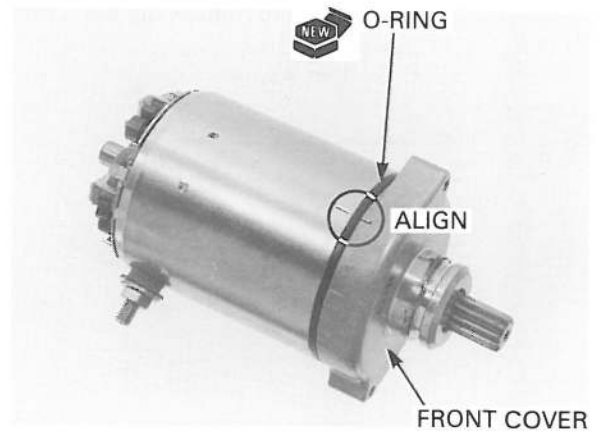

Install the same number of thrust washers in the same locations as when disassembled.



Install the new O-ring.
Apply thin coat of grease to the armature shaft end.
Install the rear cover aligning its groove with the brush holder tab.

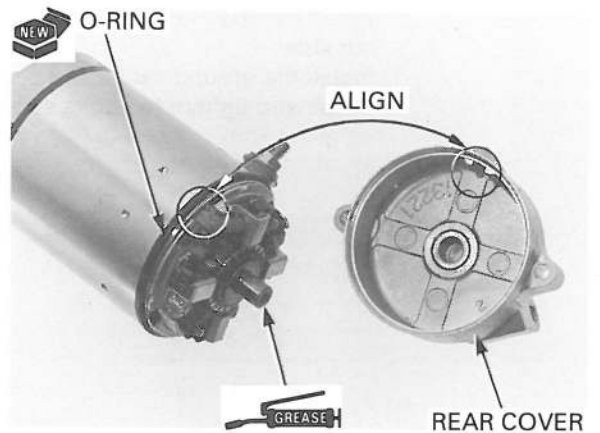

Align the index marks on the starter motor case and front cover.

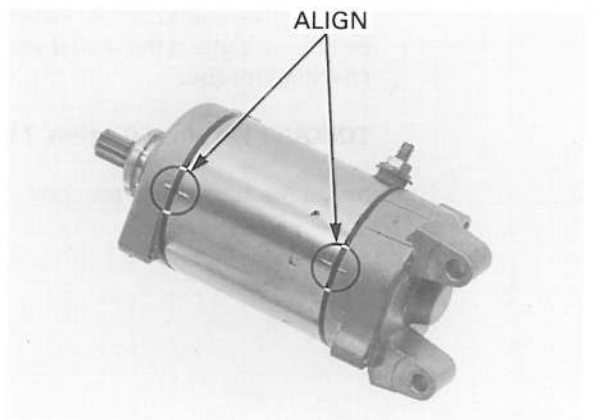

ELECTRIC STARTER

Install and tighten the bolts securely.

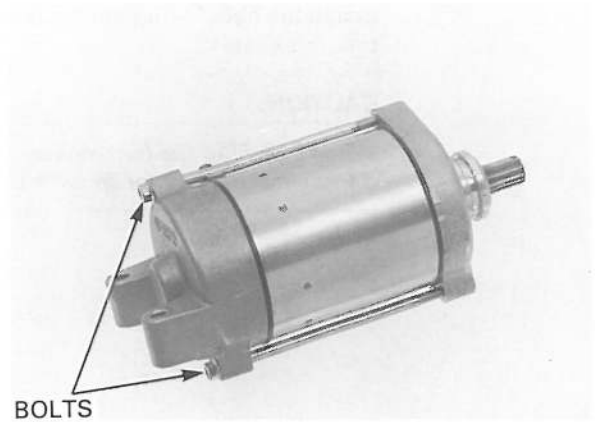

INSTALLATION

NOTE:

Route the starter motor cable and ground cable properly (page 1-29).

Apply oil to the new O-ring and install it to the starter motor groove.

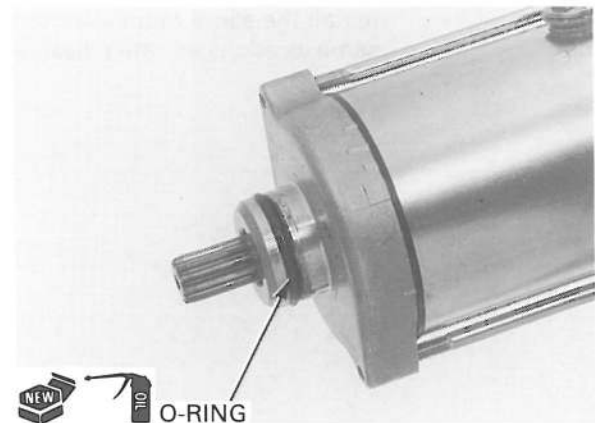

Install the starter motor onto the crankcase from the left side.
Install the ground cable.
Install and tighten the bolts securely.

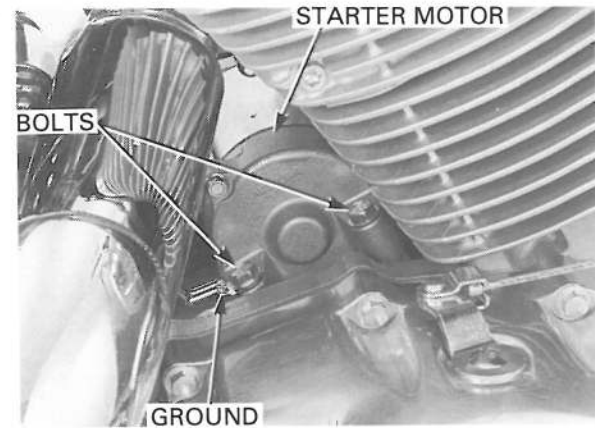

Connect the starter motor cable.
Install and tighten the starter motor cable nut to the specified torque.

TORQUE: 10 N·m (1.0 kgf·m, 7 lbf·ft)

Install the rubber cap securely.

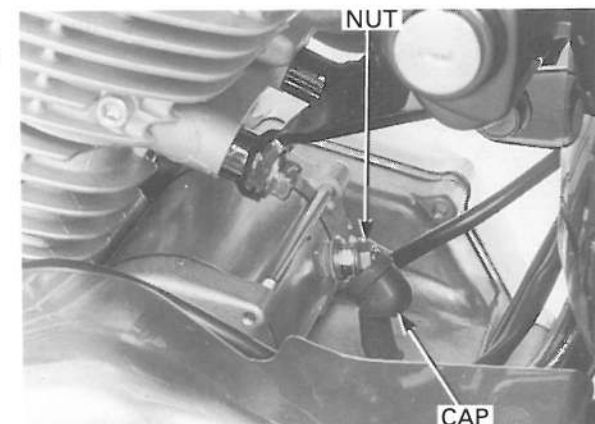

STARTER RELAY SWITCH

INSPECTION

NOTE:

Before checking the starter relay switch, check for battery condition.

Remove the left side cover (page 2-4).

Shift the transmission into neutral.
Turn the ignition switch ON and engine stop switch to RUN.

Depress the starter switch button.

The coil is normal if the starter relay switch clicks.

If you don't hear the switch "CLICK", inspect the relay switch using the procedure below.

GROUND LINE

Disconnect the starter relay switch 4P connector.
Check for continuity between the Green/Red wire (ground line) and ground.

If there is continuity when the transmission is in neutral or when the clutch is disengaged and the side stand switch is up, the ground circuit is normal (In neutral, there is a slight resistance due to the diode).

STARTER RELAY VOLTAGE

Connect the starter relay switch 4P connector.
Shift the transmission into neutral.
Measure the voltage between the Yellow/Red (+) wire and ground at the starter relay switch 4P connector.

If the battery voltage appears only when the starter switch is pressed with the ignition switch ON, it is normal.

OPERATION CHECK

Disconnect the starter relay switch 4P connector and cables.

Connect a fully charged 12 V battery positive wire to the relay switch Yellow/Red wire terminal and negative wire to the Green/Red wire terminal.

There should be continuity between the large terminals while the battery is connected, and no continuity when the battery is disconnected.

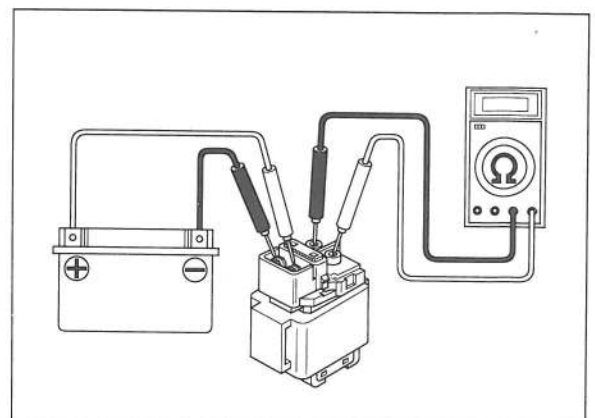
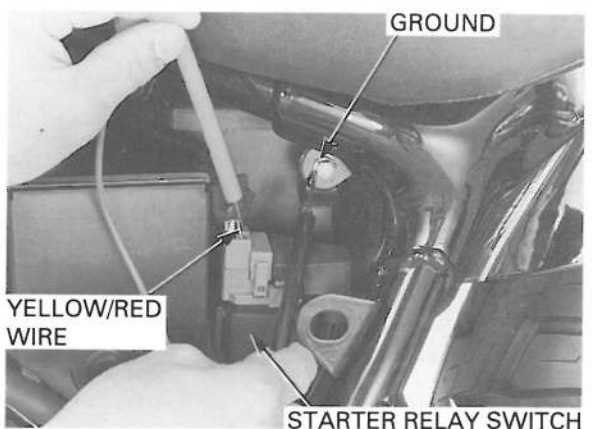
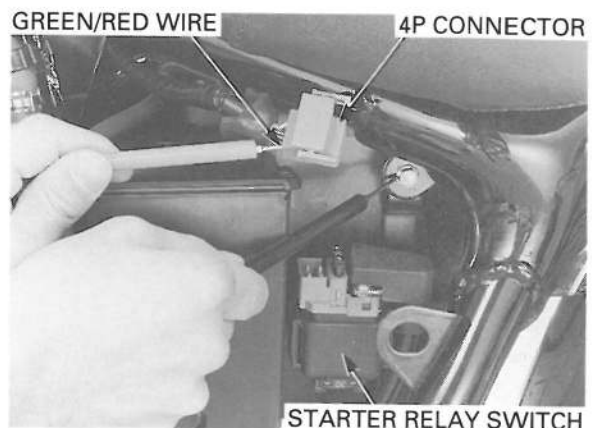

ELECTRIC STARTER

REMOVAL/INSTALLATION

Remove the left side cover (page 2-4).

Disconnect the starter relay 4P connector.

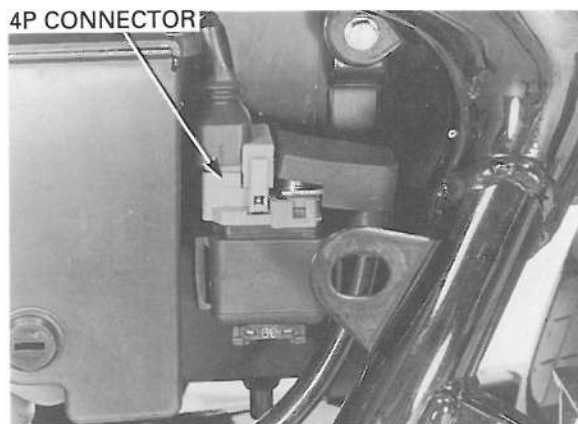

Remove the socket bolts and cables.
Remove the starter relay switch.

Installation is in the reverse order of removal.

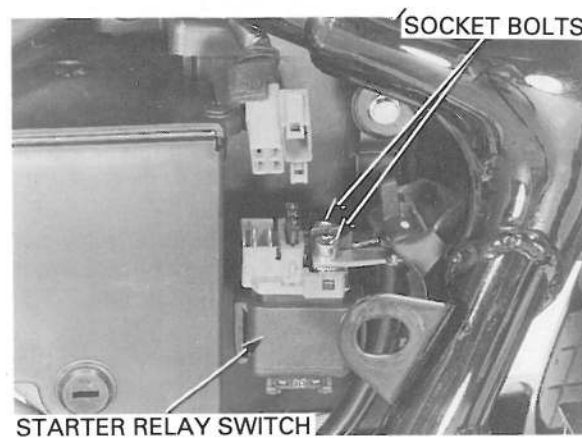

CLUTCH DIODE

INSPECTION

Remove the right side cover (page 2-4).

Open the fuse box and remove the diode.



Check for continuity between the diode terminals.
When there is continuity, a small resistance value
will register.

If there is continuity in one direction, the diode is
normal.

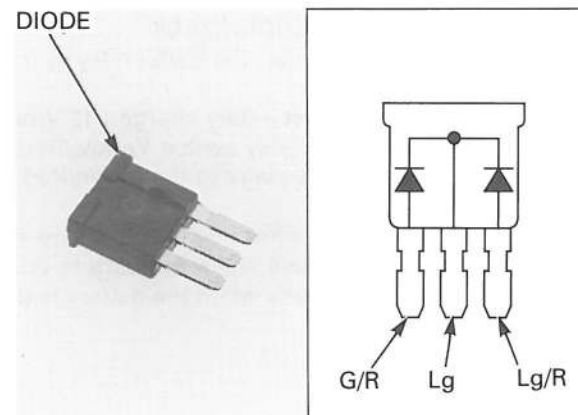

MEMO

SYSTEM DIAGRAM

VT750C :
VT750CD/CD2 ('98 - 2000) :

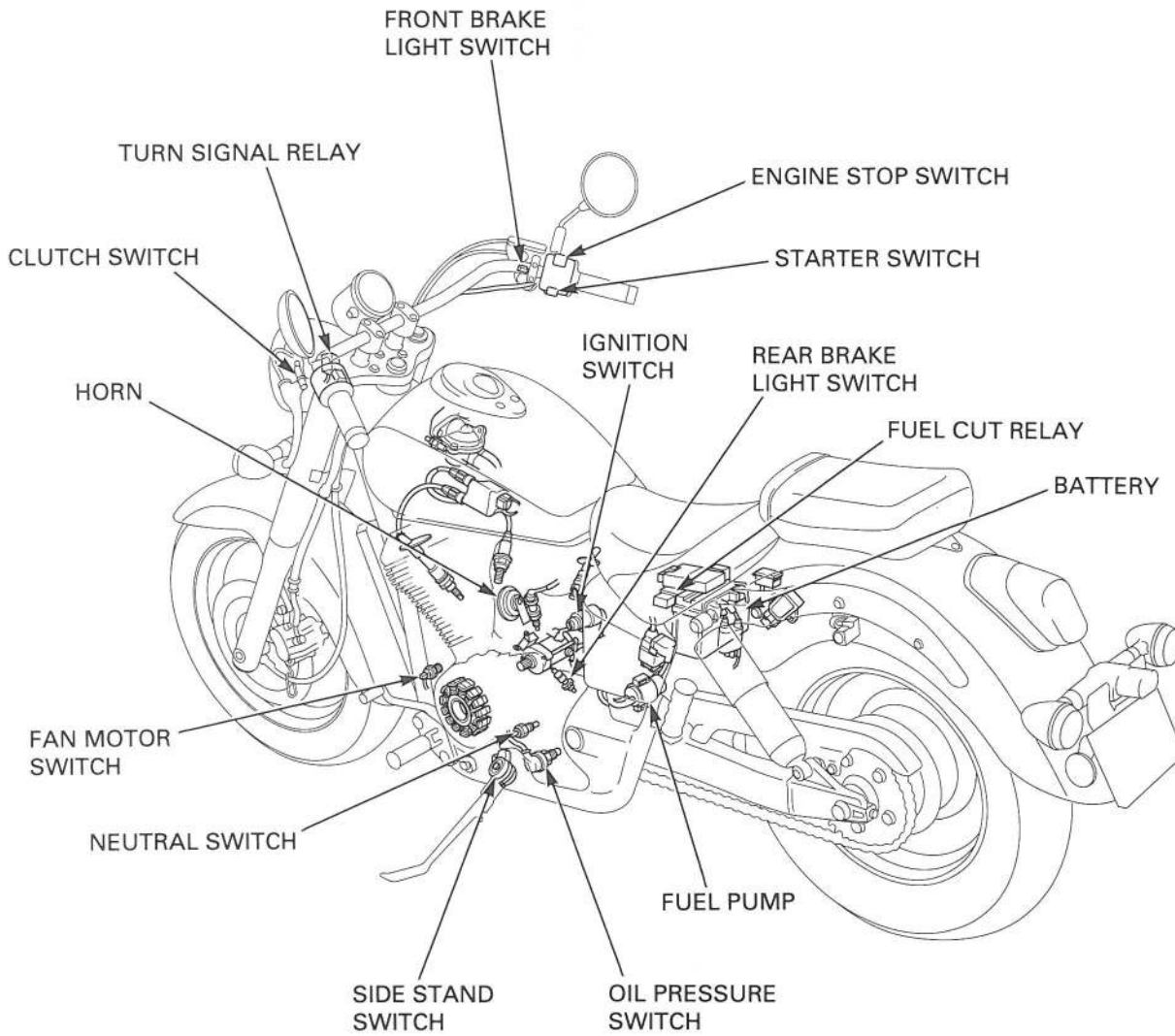

19. LIGHTS/METERS/SWITCHES

VT750CD/CD2 (After 2000) :
VT750C3/CD3 :

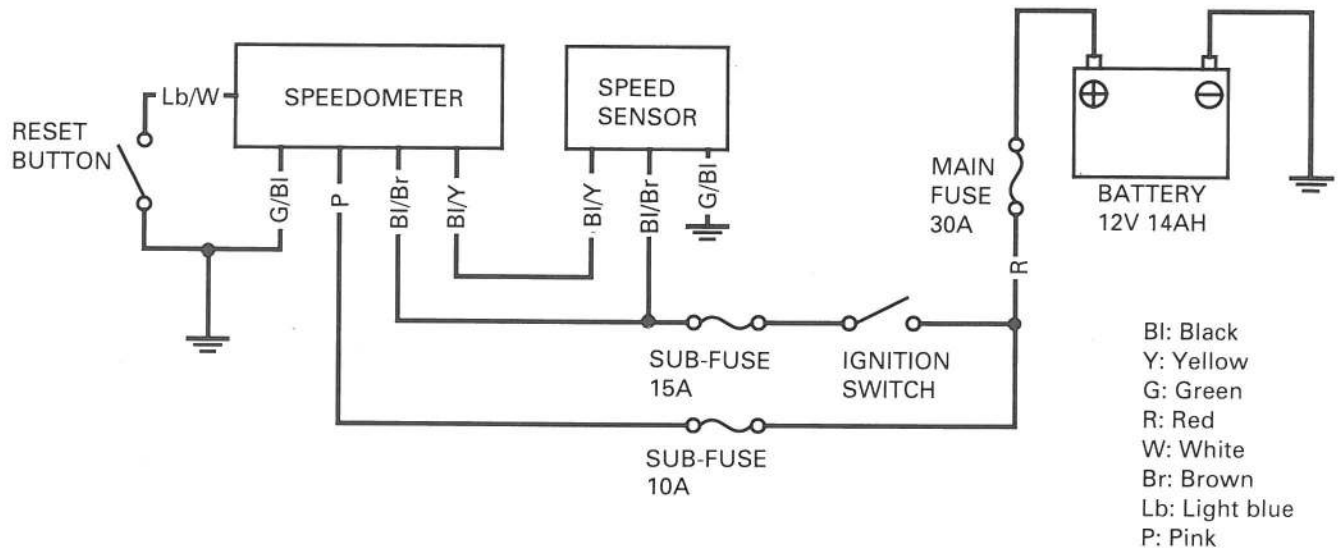
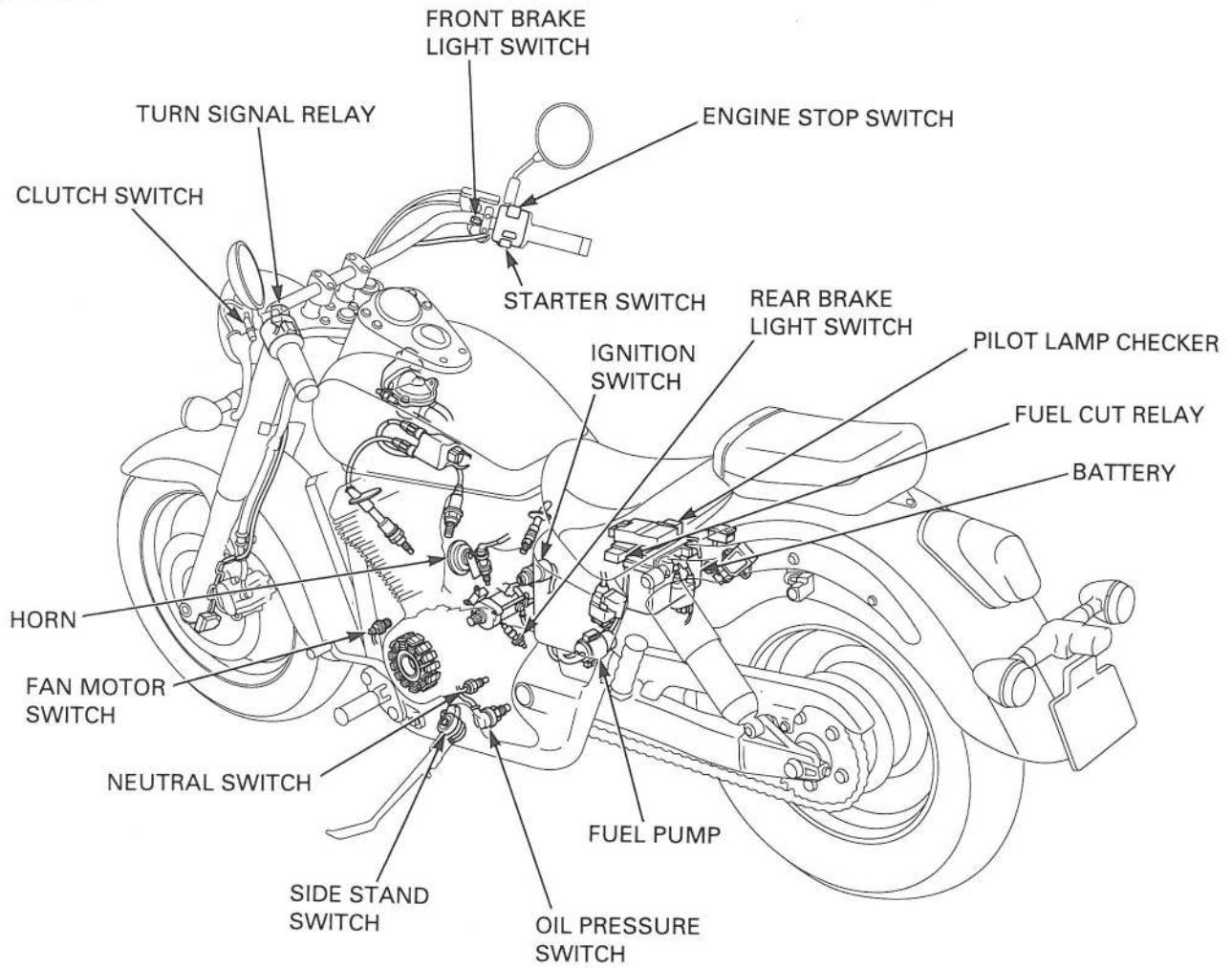

SYSTEM DIAGRAM	19-0	REAR BRAKE LIGHT SWITCH	19-16
SERVICE INFORMATION	19-2	CLUTCH SWITCH	19-17
TROUBLESHOOTING (VT750CD/CD2 (AFTER 2000), VT750C3/CD3)	19-4	HANDLEBAR SWITCH	19-17
BULB REPLACEMENT	19-7	IGNITION SWITCH	19-18
SPEEDOMETER	19-10	FAN MOTOR SWITCH	19-19
SPEED SENSOR (VT750CD/CD2 (AFTER 2000), VT750C3/CD3)	19-13	COOLANT TEMPERATURE, THERMO SWITCH	19-20
OIL PRESSURE SWITCH	19-14	HORN	19-22
NEUTRAL SWITCH	19-15	TURN SIGNAL RELAY	19-23
FRONT BRAKE LIGHT SWITCH	19-16	SIDE STAND SWITCH	19-23

SERVICE INFORMATION

GENERAL

WARNING

- *A halogen headlight bulb becomes very hot while the headlight is ON, and remains hot for a while after it is turned OFF. Be sure to let it cool down before servicing.*
 - *Use an electric heating element to heat the water/coolant mixture for the thermosensor inspection. Keep all flammable materials away from the electric heating element. Wear protective clothing, insulated gloves and eye protection.*
-
- Note the following when replacing the halogen headlight bulb.
 - Wear clean gloves while replacing the bulb. Do not put finger prints on the headlight bulb, as they may create hot spots on the bulb and cause it to break.
 - If you touch the bulb with your bare hands, clean it with a cloth moistened with alcohol to prevent its early failure.
 - Be sure to install the dust cover after replacing the bulb.
 - All plastic connectors have locking tabs that must be released before disconnecting, and must be aligned when reconnecting.
 - Always turn off the ignition switch before disconnecting any electrical component.
 - A continuity test can be made with switches installed on the motorcycle.
 - Check the battery condition before performing any inspection that requires proper battery voltage.
 - If you disconnect the battery terminal, the trip meter memory is erased (:VT750CD/CD2 (After 2000), VT750C3/CD3).

ITEM		SPECIFICATIONS	
Bulbs	Headlight (High/Low beam)	12 V – 60/55 W	
	Brake/tail light	12 V – 32/3 CP	
	Front turn signal/running light	12 V – 21/5 W × 2	
	Rear turn signal light	12 V – 21 W × 2	
	License light	12 V – 5 W	
	Speedometer light	VT750C	12 V – 3.4 W
		VT750CD/CD2 ('98 – 2000)	
		VT750CD/CD2 (After 2000)	12 V – 1.7 W
		VT750C3/CD3	
	Turn signal indicator	12 V – 3.4 W	
	High beam indicator	12 V – 3.4 W	
	Neutral indicator	12 V – 3.4 W	
	Side stand indicator	VT750CD/CD2 (After 2000)	12 V – 3.4 W
VT750C3/CD3			
Oil indicator	VT750CD/CD2 (After 2000)	12 V – 3.4 W	
	VT750C3/CD3		
Temp indicator	VT750CD/CD2 (After 2000)	12 V – 3.4 W	
	VT750C3/CD3		
Fuse	Main fuse	30 A	
	Sub-fuse	10 A × 4, 15 A × 1	
Fan motor switch	Starts to close (ON)	98 – 102 °C (208 – 216 °F)	
	Starts to open (OFF)	93 – 97 °C (199 – 207 °F)	
Coolant temperature sensor	Starts to close (ON)	112 – 118 °C (259 – 270 °F)	
	Starts to open (OFF)	Below 108 °C (252 °F)	

TORQUE VALUES

Oil pressure switch	12 N•m (1.2 kgf•m, 9 lbf•ft)	Apply sealant to the threads
Neutral switch	12 N•m (1.2 kgf•m, 9 lbf•ft)	
Handlebar switch screw	3 N•m (0.3 kgf•m, 2.2 lbf•ft)	
Fan motor switch	18 N•m (1.8 kgf•m, 13 lbf•ft)	Apply sealant to the threads
Thermo sensor	12 N•m (1.2 kgf•m, 9 lbf•ft)	Apply sealant to the threads
Side stand switch mounting bolt	10 N•m (1.0 kgf•m, 7 lbf•ft)	ALOC bolt: Replace with a new one

TROUBLESHOOTING (VT750CD/CD2 (AFTER 2000), VT750C3/CD3)

Speed sensor/Speedometer

NOTE:

- The speed sensor sends digital pulse signals to the speedometer.
- When the speedometer or odometer/trip meter operates abnormally, replace the speedometer assembly.

The odometer/trip meter operate normally, but the speedometer does not operate

- Faulty speedometer

The speedometer operates normally, but the odometer/trip meter does not operate

- Faulty odometer/trip meter

The speedometer indication error is large

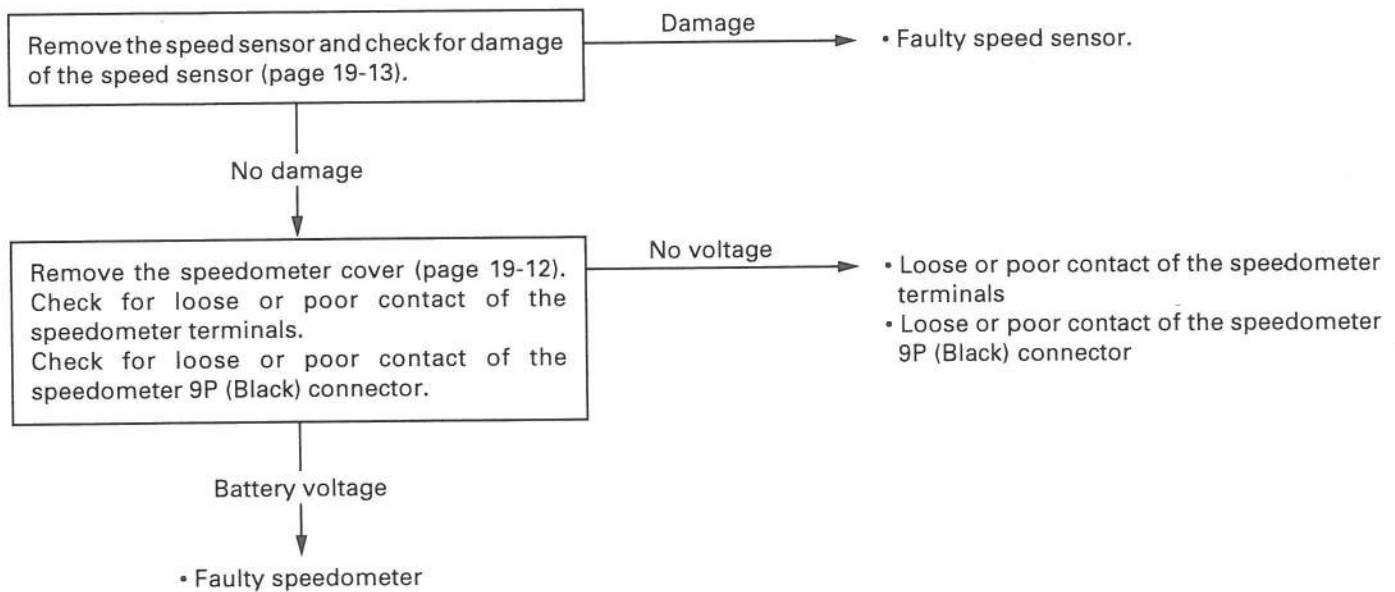

The speedometer and odometer/trip meter does not operate

- Check for the following before diagnosing.
 - blown main fuse (30A) or sub-fuse (10A).
 - loose or corroded terminals of the connectors.
 - discharged battery.

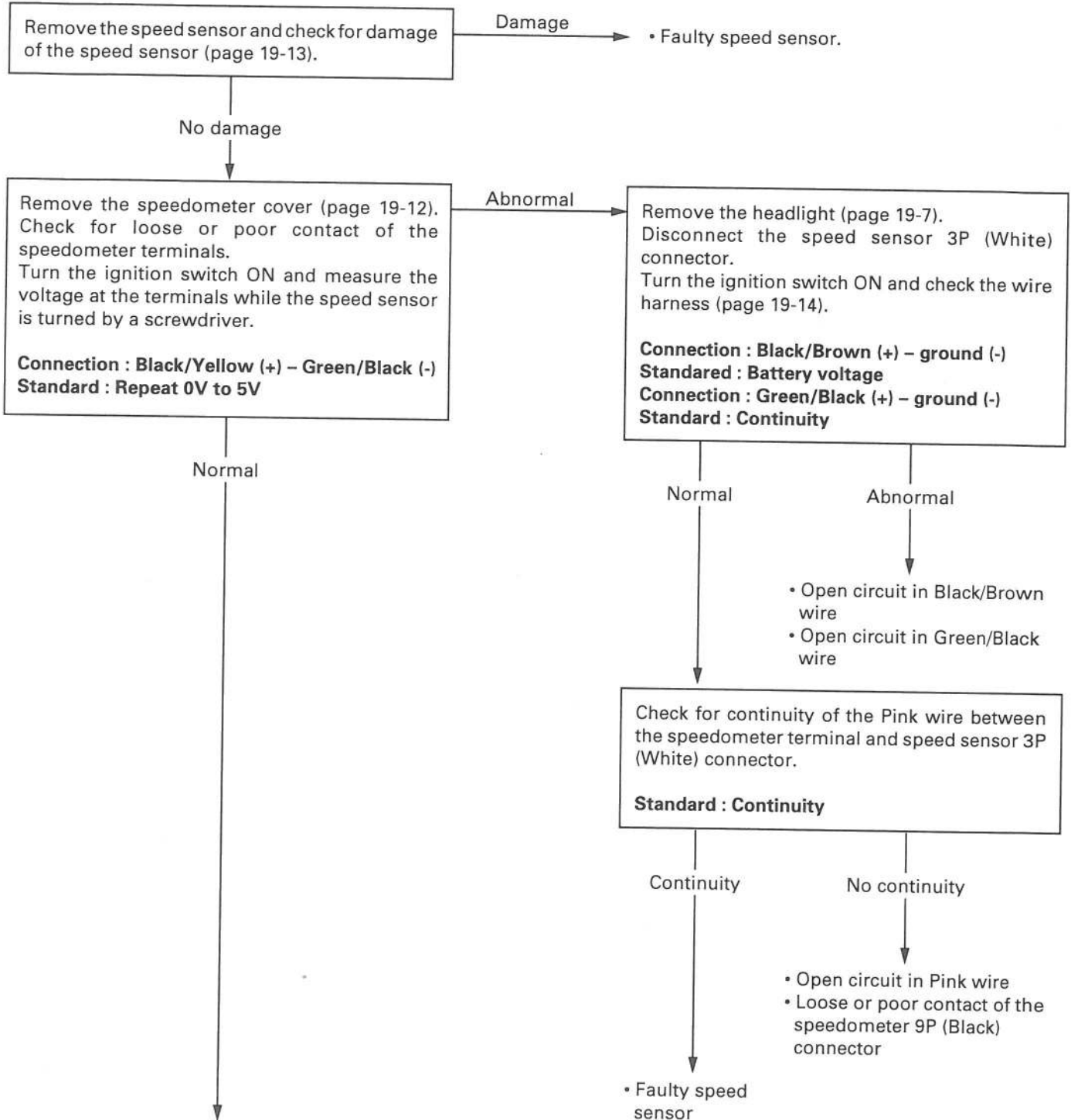

LIGHTS/METERS/SWITCHES

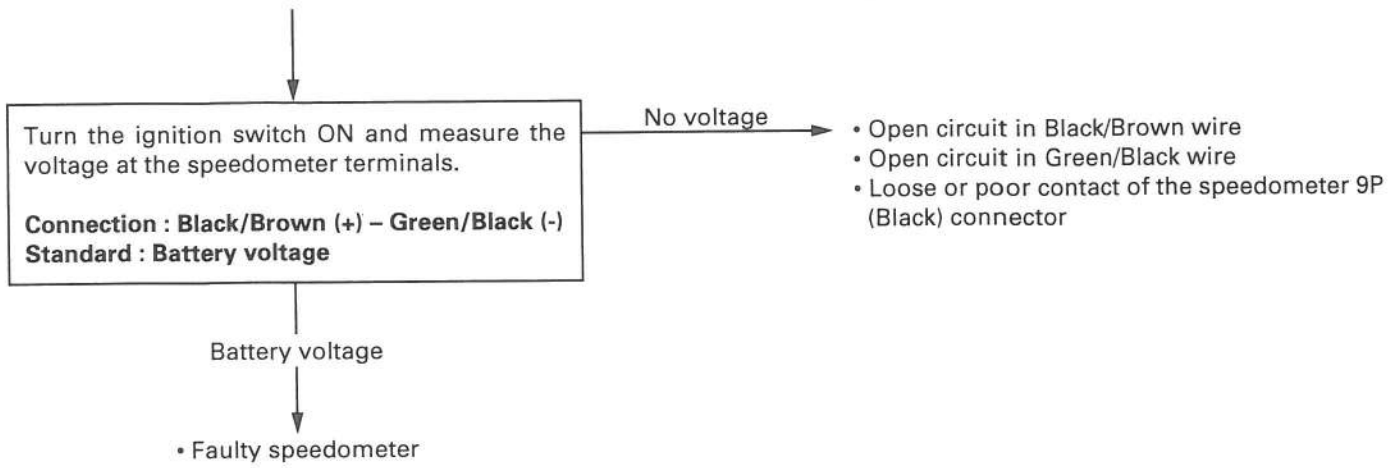

BULB REPLACEMENT

HEADLIGHT

⚠ WARNING

A halogen headlight bulb becomes very hot while the headlight is ON, and remains hot for a while after it is turned OFF. Be sure to let it cool down before servicing.

CAUTION:

- *Wear clean gloves while replacing the bulb. Do not put fingerprints on the headlight bulb, as they may create hot spots on the bulb and cause it to break.*
- *If you touch the bulb with your bare hands, clean it with a cloth moistened with alcohol to prevent its early failure.*
- *Be sure to install the dust cover after replacing the bulb.*

Remove the bolts, collars and headlight.

Disconnect the headlight bulb socket and remove the dust cover.

Unhook the bulb retainer and remove the headlight bulb.

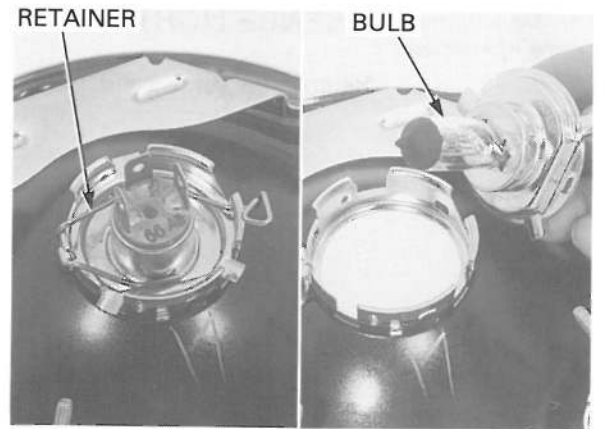
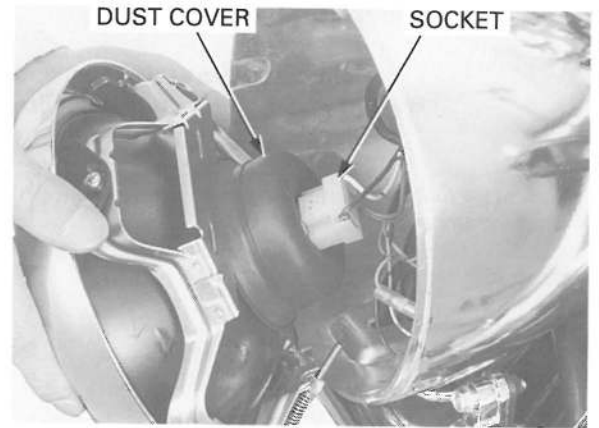
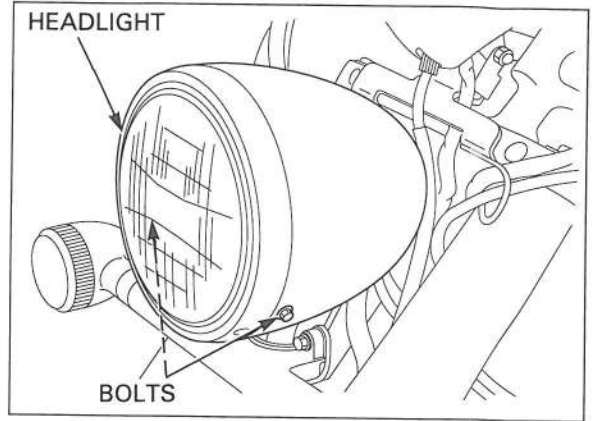

Install the dust cover with its "TOP" mark facing up.

Installation is in the reverse order of removal

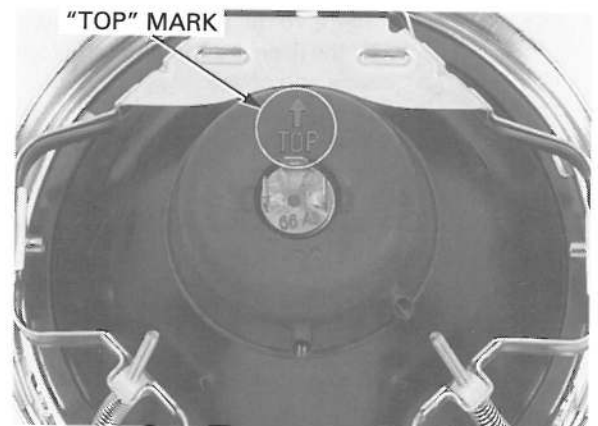

TURN SIGNAL LIGHT

Remove the screw and turn signal lens. While pushing in, turn the bulb counterclockwise to remove it and replace with a new one.

Installation is in the reverse order of removal.

NOTE:

- When performing turn signal light lens installation, align the tab on the lens with the groove on the turn signal light case.
- Seat the rubber packing properly.

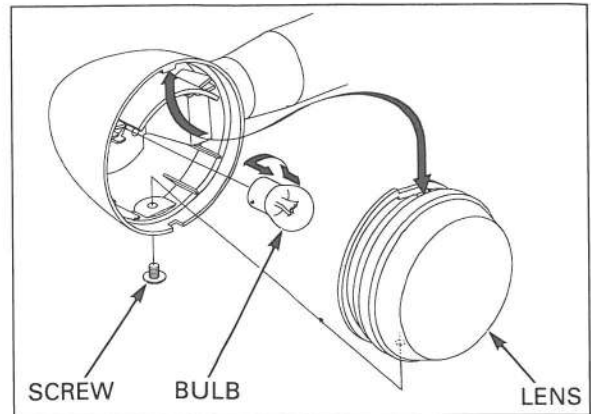

TAIL/BRAKE LIGHT

Remove the screws and tail/brake light lens. While pushing in, turn the bulb counterclockwise to remove it and replace with a new one.

Seat the rubber packing properly.

Installation is in the reverse order of removal.

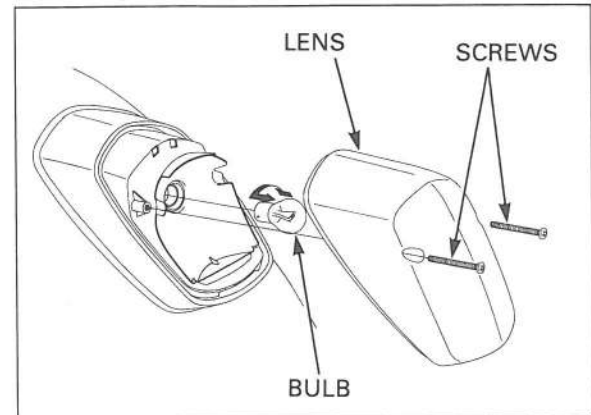

Do not damage the wire harness.

LICENSE LIGHT

Remove the screws and license light cover.

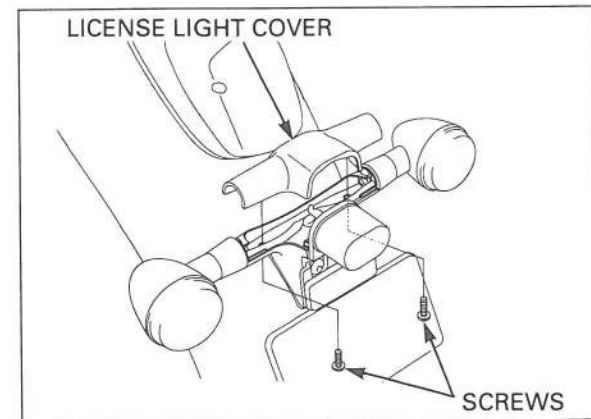

Remove the lens attaching nuts on the reverse side of the license plate base and remove the license light lens and cover.

While pushing in, turn the bulb counterclockwise to remove it.

Installation is in the reverse order of removal.

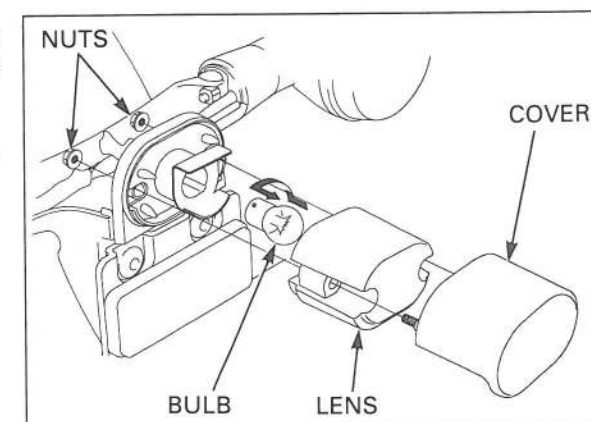

INDICATOR LIGHT

Remove the indicator light lens.

Remove the bulb socket.
 Replace a new bulb and install it in the reverse order of removal.

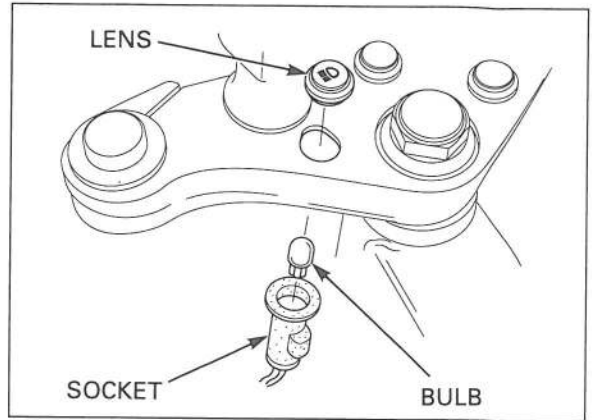

*VT750C3/CD3 and
 VT750CD/CD2
 (after 2000):*

NOTE:

The speedometer cover must be removed from the fuel tank before servicing the speedometer cover side indicator light.
 - Refer to speedometer cover removal/installation (page 19-12)

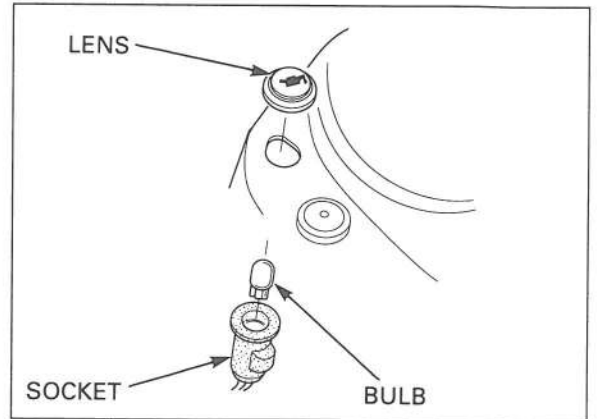

*VT750C and
 VT750CD/CD2
 (98 - 2000):*

SPEEDOMETER LIGHT

Disconnect the speedometer cable from the speedometer

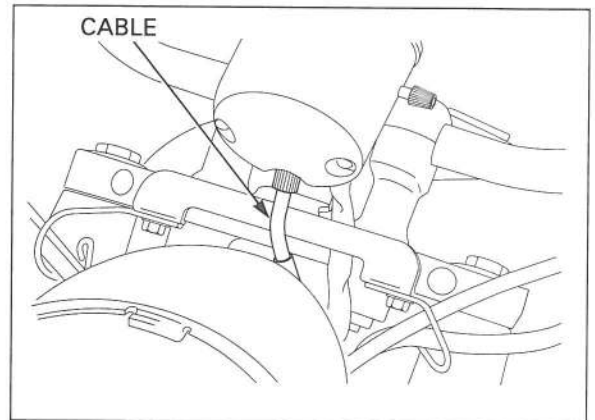

Remove the speedometer cover mounting screws and cover.

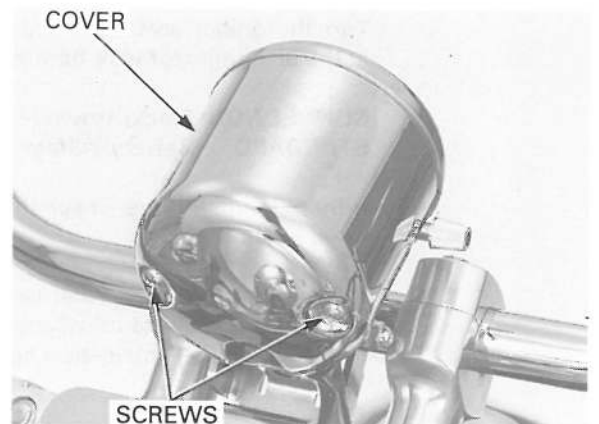

LIGHTS/METERS/SWITCHES

Remove the bulb socket from the speedometer.
Remove the speedometer bulb from the bulb socket.
Replace a new bulb and install it in the reverse order of removal.

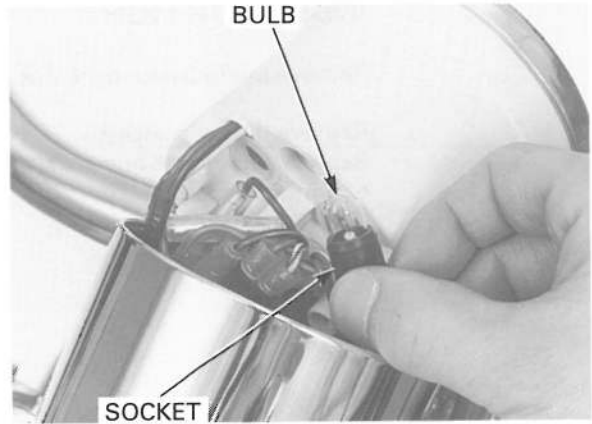

SPEEDOMETER

*VT750C3/CD3 and
VT750CD/CD2
(after 2000):*

INSPECTION

Check that the main fuse (30 A) or sub-fuse (10 A, 15 A) is not blown.

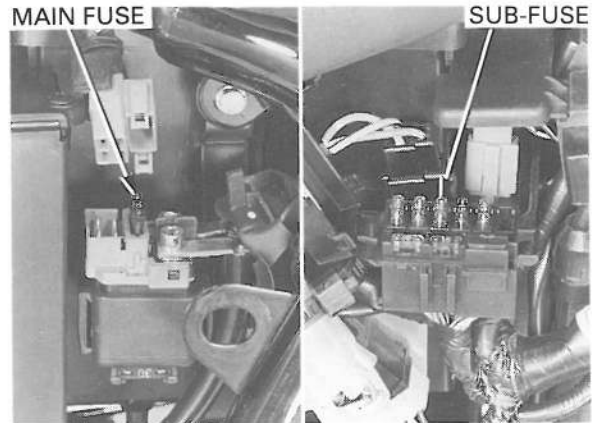

Remove the speedometer (page 19-12).

Disconnect the speedometer 9P connector.

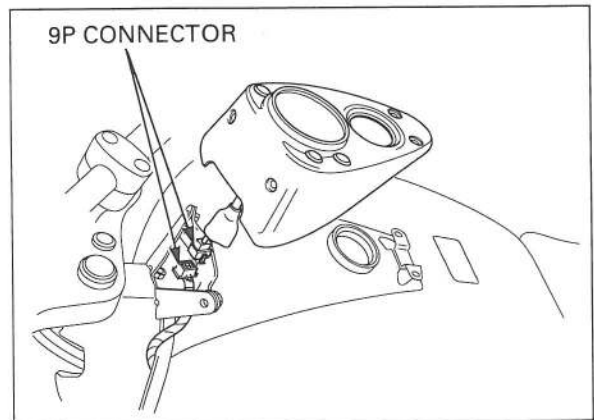

Turn the ignition switch ON and measure the voltage at the 9P connector wire harness side.

CONNECTION: Black/Brown (+) – Green/Black (-)
STANDARD: Battery voltage

If there is no voltage, check the related circuit for open or short circuit.

If the related circuit is normal, temporarily disconnect the battery positive terminal and reset the meter (see Owner's manual) and inspect again.

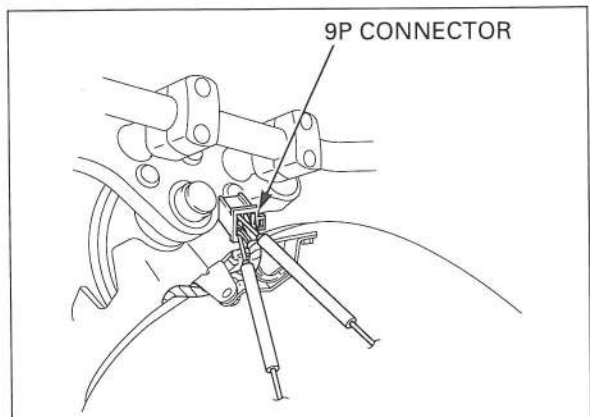

Measure the voltage at the 9P connector wire harness side.

CONNECTION: Pink (+) – Green/Black (–)
STANDARD: Battery voltage

If there is no voltage, check the related circuit for open or short circuit.

If the related circuit is normal, temporarily disconnect the battery positive terminal and reset the meter (see Owner's manual) and inspect again.

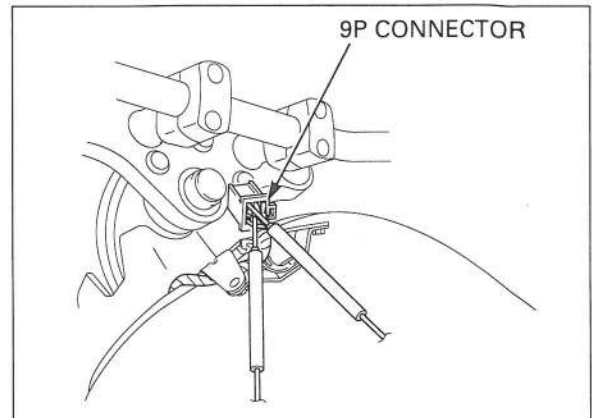

*VT750C and
VT750CD/CD2
('98 – 2000):*

REMOVAL/INSTALLATION

Remove the headlight (page 19-7).
Disconnect the speedometer 6P (Black) connector.



Disconnect the speedometer cable from the speedometer

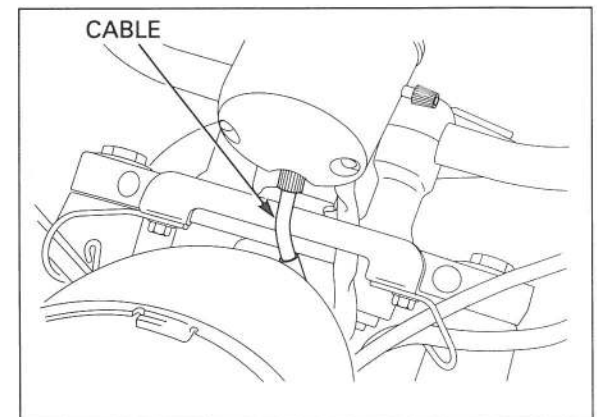

Remove the speedometer mounting nut/bolt and meter from the speedometer stay.

Installation is in the reverse order of removal.

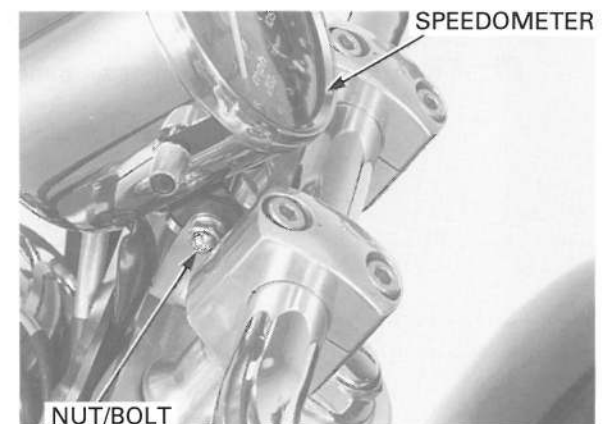

LIGHTS/METERS/SWITCHES

VT750C3/CD3 and
VT750CD/CD2
(after 2000):

REMOVAL/INSTALLATION

⚠ WARNING

Gasoline is extremely flammable and explosive under certain conditions. KEEP OUT OF REACH OF CHILDREN.

Remove the fuel tank mounting bolt (page 2-4) and lift the fuel tank upward.

Disconnect the speedometer 9P connector.

Remove the speedometer cover mounting bolts, collars and grommets.
Remove the fuel tank cap.
Remove the speedometer cover from the fuel tank.

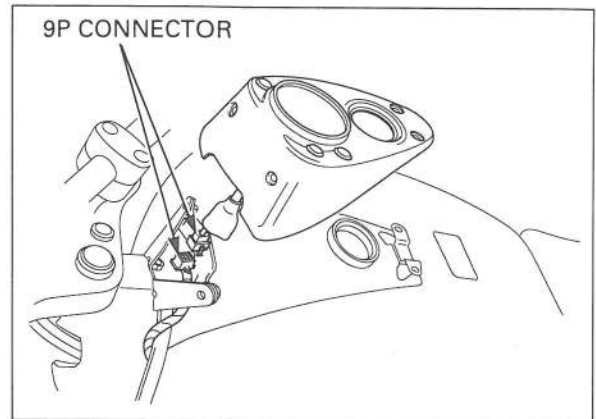
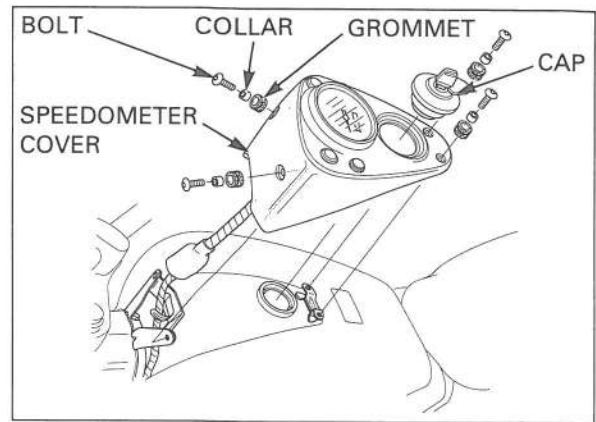

Remove the speedometer light, indicator light and trip meter reset button from the speedometer cover (page 19-9).
Remove the screws and speedometer from the cover.

Installation is in the reverse order of removal.

NOTE:

Route the wire harness properly.

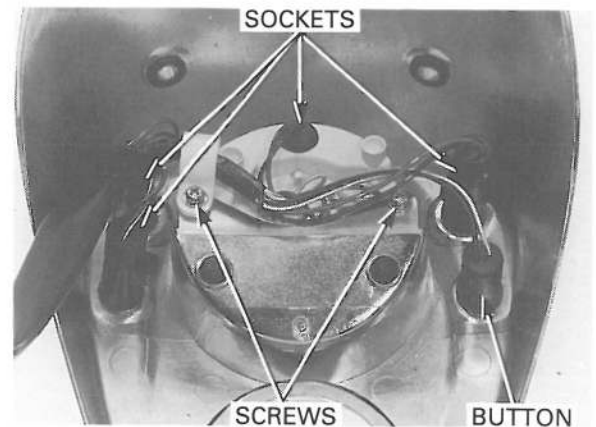

VT750C and
VT750CD/CD2
(98 - 2000):

DISASSEMBLY

Remove the speedometer (page 19-11).

Remove the screws and speedometer cover.
Remove the speedometer stay.

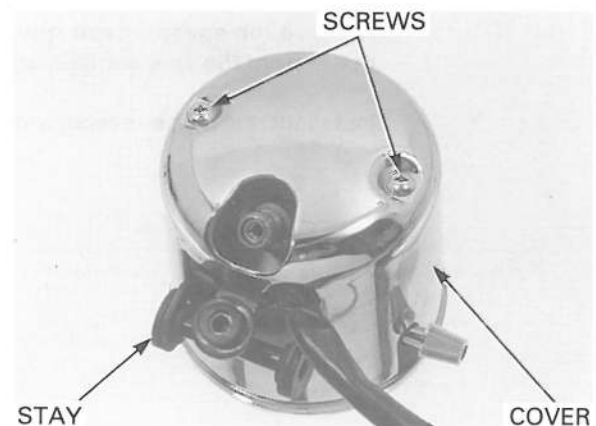

Remove the clamp and speedometer light from the speedometer.
 Remove the wire harness from the speedometer.
 Assembly is in the reverse order of disassembly.

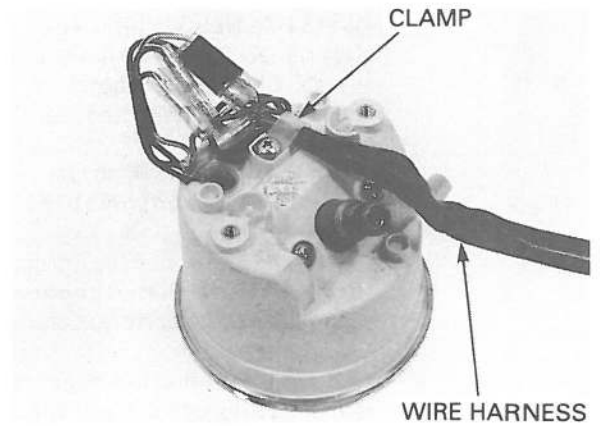

SPEED SENSOR (VT750CD/CD2 (AFTER 2000), VT750C3/CD3)

INSPECTION

NOTE:

- Check for the following before diagnosing:
- blown main fuse (30A) or sub-fuse (10A)
 - loose or corroded terminals of the connectors
 - discharged battery

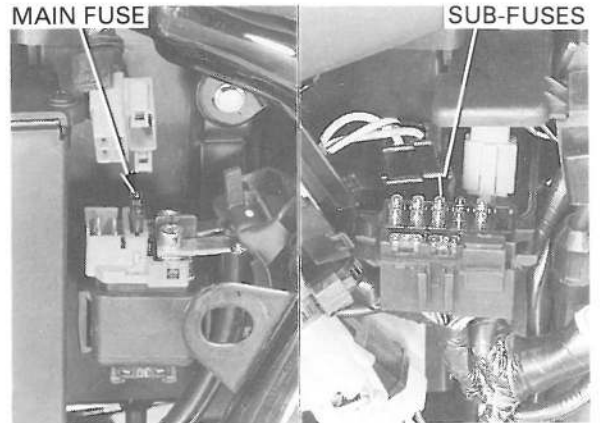

Remove the mounting screw and speed sensor.

Check that the speed sensor turns smoothly.
 If the speed sensor does not turn smoothly, replace it with a new one.
 Install the speed sensor in the reverse order of removal.

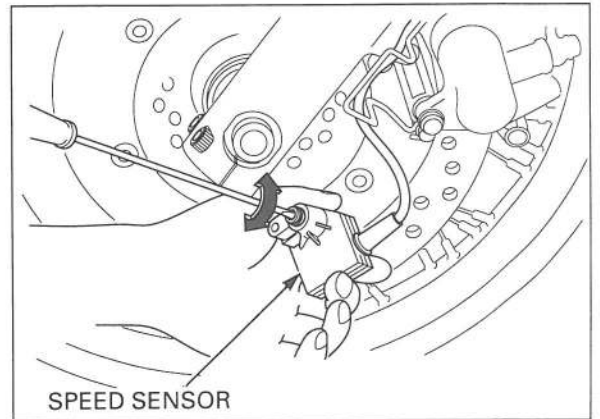

OUTPUT SIGNAL INSPECTION

Turn the ignition switch ON.
 Measure the voltage at the terminals while the speed sensor is turned by a screwdriver.

CONNECTION: Black/Yellow (+) – Green/Black(-)
STANDARD: Repeat 0V to 5V

If the measured value is out of specification, inspect the following:
 Turn the ignition switch ON.
 Measure the voltage at the speedometer terminals.

CONNECTION: Black/Brown (+) – Green/Black (-)
STANDARD: Battery voltage

If the measured value is out of specification, inspect the wire harness.

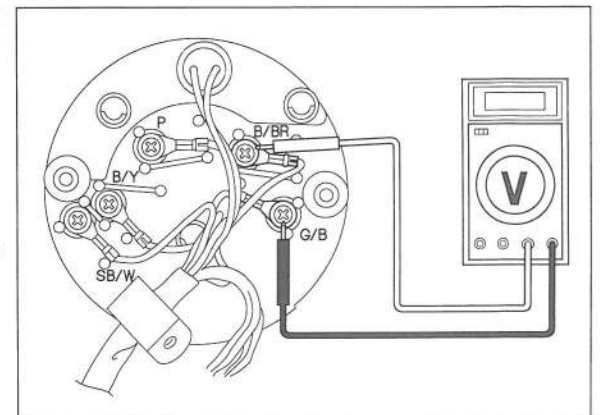

LIGHTS/METERS/SWITCHES

WIRE HARNESS INSPECTION

Disconnect the speed sensor 3P connector.
Check the continuity between Green/Black terminal of 3P connector wire harness side and ground.

Turn the ignition switch ON.
Measure the voltage at the 3P connector wire harness side.

CONNECTION: Black/Brown (+) – ground (-)
STANDARD: Battery voltage

If the measured value is out of specification, check for continuity of the Pink wire between the speedometer 9P (Black) connector and speed sensor 3P (White) connector.

STANDARD: Continuity

If the measured value is out of specification, inspect the wire harness.

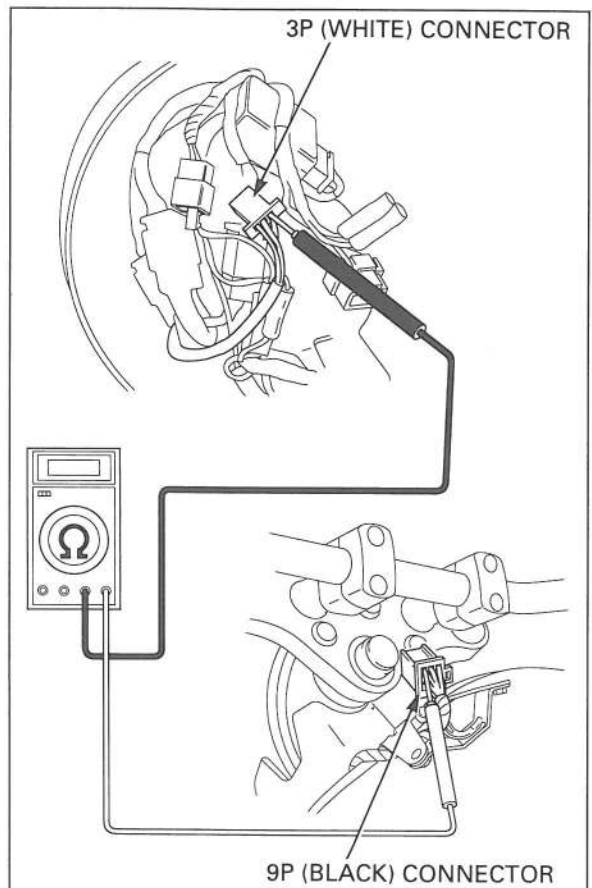
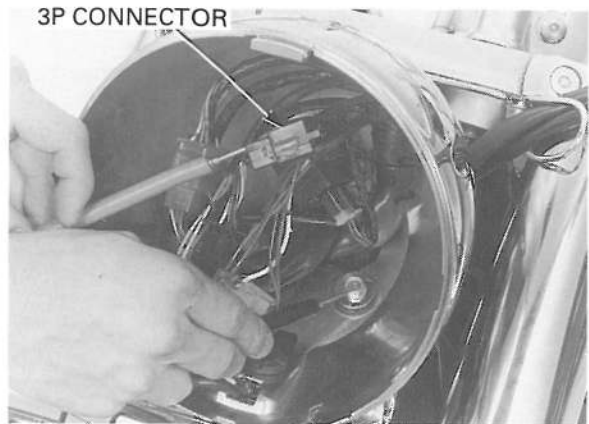

OIL PRESSURE SWITCH

NOTE:

The oil pressure switch removal/installation procedure is on page 4-3.

Make sure that the oil pressure warning indicator comes on with the ignition switch "ON".

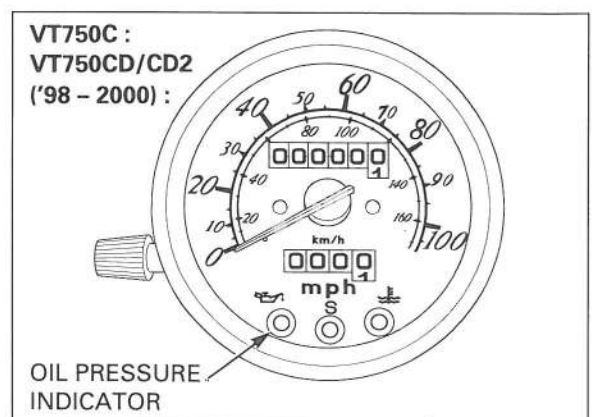

If the indicator does not come on, inspect as follows:
 Remove the left rear cover (page 7-3).
 Disconnect the oil pressure switch wire from the switch by removing the terminal screw.
 Short it to ground using a jumper wire. Turn the ignition switch "ON".

The oil pressure warning indicator should come on.
 If the indicator does not come on, check the sub-fuse (10A) and wires for a loose connection or an open circuit.

Start the engine and make sure that the indicator goes out. If the indicator does not go out, check the oil pressure (page 4-3).
 If the oil pressure is normal, replace the oil pressure switch (page 4-3).

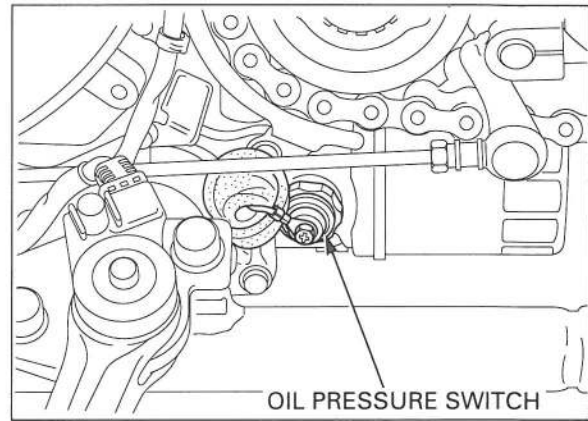
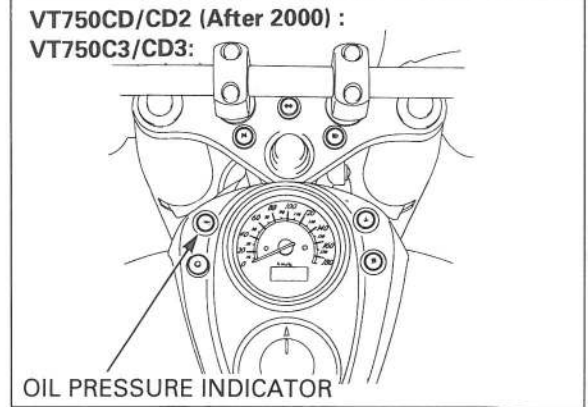

NEUTRAL SWITCH

INSPECTION

Remove the right side cover (page 2-4).

Disconnect the engine sub-harness 2P (Black) connector.

Shift the transmission into neutral and check for continuity between the Light green/Red wire and ground.

There should be continuity when the transmission is in neutral.

There should be no continuity when the transmission is in any other gear.

REMOVAL/INSTALLATION

Remove the left rear cover (page 7-4).

Disconnect the neutral switch connector.

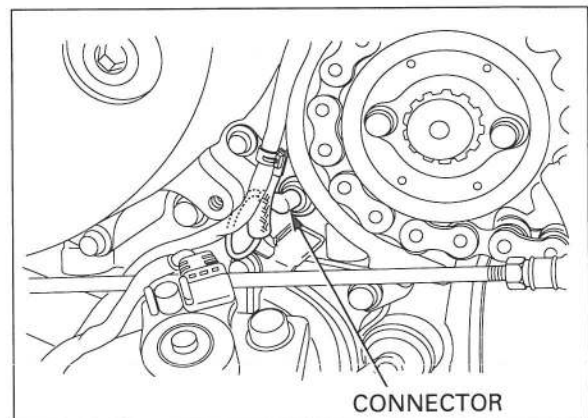
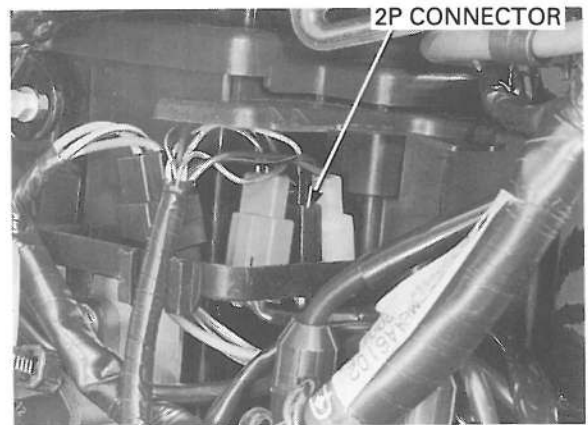

LIGHTS/METERS/SWITCHES

Remove the neutral switch.

Install and tighten the neutral switch to the specified torque.

TORQUE: 12 N·m (1.2 kgf·m, 9 lbf·ft)

Connect the neutral switch connector.

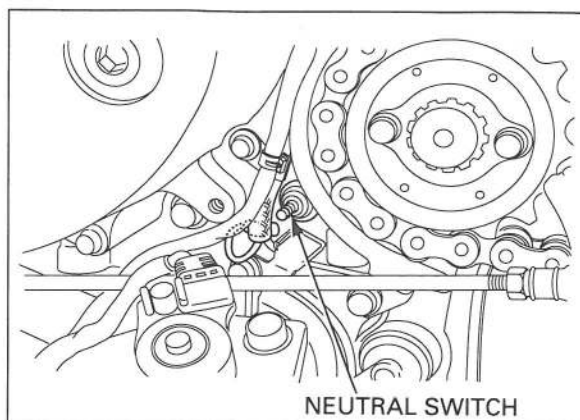

FRONT BRAKE LIGHT SWITCH

NOTE:

The front brake light switch removal/installation procedure is on pages 15-8,11.

Disconnect the front brake light switch connectors and check for continuity.

There should be continuity with the front brake applied and no continuity with it released.

FRONT BRAKE LIGHT SWITCH

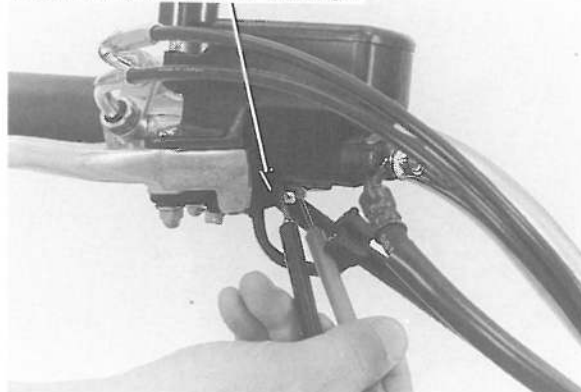

REAR BRAKE LIGHT SWITCH

Remove the fuel tank (page 2-4).

Disconnect the rear brake light switch 2P (Black) connector and check for continuity at the switch side connector.

There should be continuity with the rear brake applied and no continuity with it released.

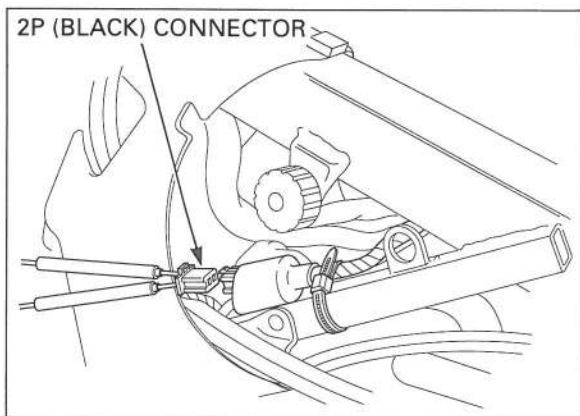
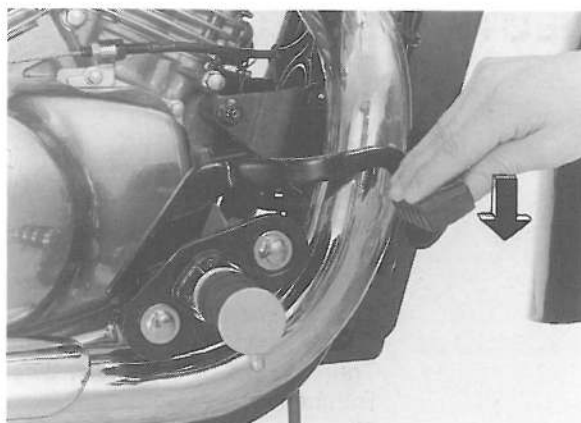

CLUTCH SWITCH

NOTE:

The clutch switch removal/installation procedure is on pages 13-7,12.

Disconnect the clutch switch connectors and check for continuity.

There should be continuity with the clutch lever applied and no continuity with it released.

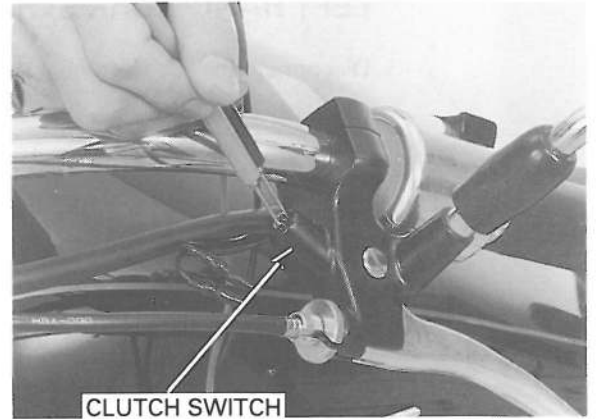

HANDLEBAR SWITCH

NOTE:

The handlebar switches removal/installation procedure is on pages 13-7, 10.

Remove the headlight (page 19-7).

Check for continuity between the terminals. Continuity should exist between the color code wire as shown in each chart.

RIGHT HANDLEBAR SWITCH

Disconnect the right handlebar 9P connector.

STARTER SWITCH

	BI/W	Y/R
Free		
Push	○	○

ENGINE STOP SWITCH

	BI/G	BI/W
Off		
Run	○	○

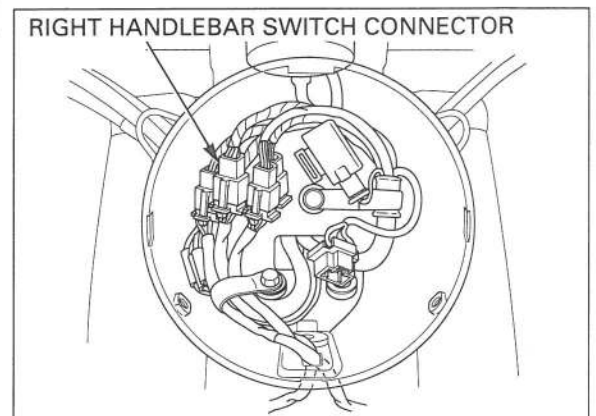
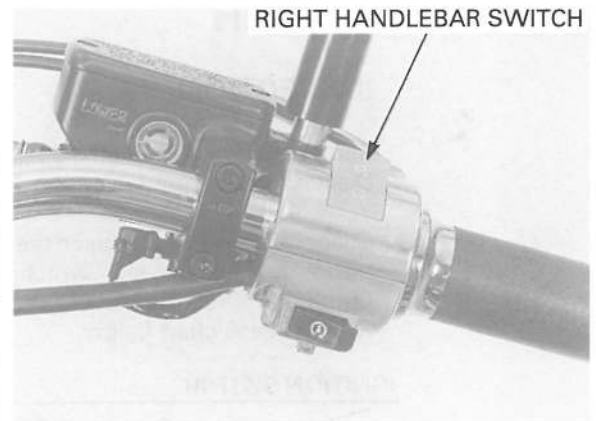

LIGHTS/METERS/SWITCHES

LEFT HANDLEBAR SWITCH

Disconnect the left handlebar 9P connector.

DIMMER SWITCH

	Bu/W	Bu	W
Lo	○	○	○
(N)	○	○	○
H	○	○	

TURN SIGNAL SWITCH

	Gr	Lb	O	Br/Bl	Lb/W	O/W
Right	○	○		○	○	○
N				○	○	○
Left	○		○	○	○	

HORN SWITCH

	Bl/Br	Lg
Free		
Push	○	○

LEFT HANDLEBAR SWITCH

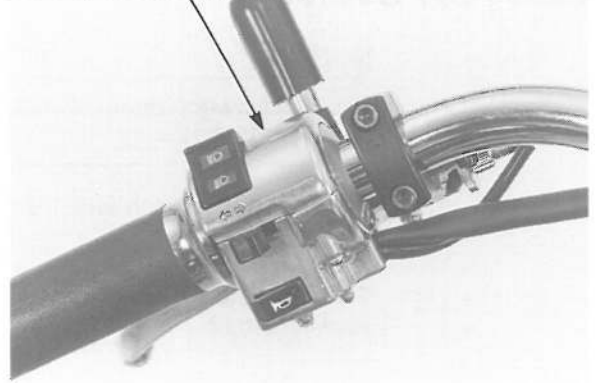

LEFT HANDLEBAR SWITCH CONNECTOR

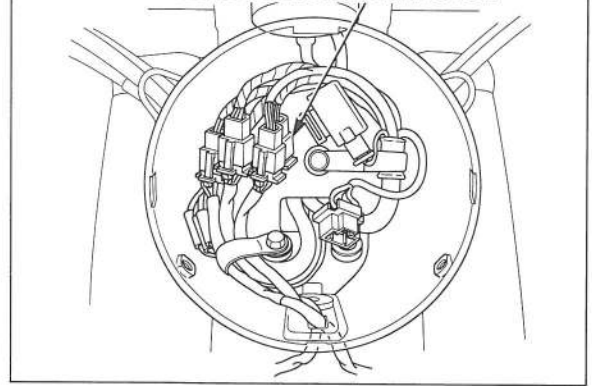

IGNITION SWITCH

INSPECTION

Remove the seat and left side cover (page 2-4). Disconnect the ignition switch 4P connector.

Check for continuity between the ignition switch connector terminals in each switch position. Continuity should exist between the color coded wires in each chart below.

IGNITION SWITCH

	R	R/Bl	Bu/O
On	○	○	○
Off			

REMOVAL/INSTALLATION

Disconnect the ignition switch 4P connector (see above).

Remove the two screws and ignition switch cover. Remove the two bolts and ignition switch.

Installation is in the reverse order of removal.

4P CONNECTOR

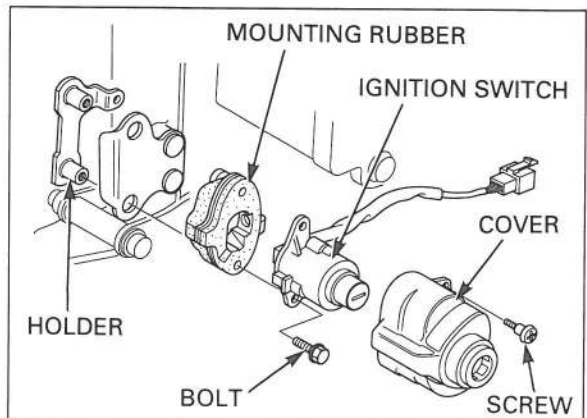
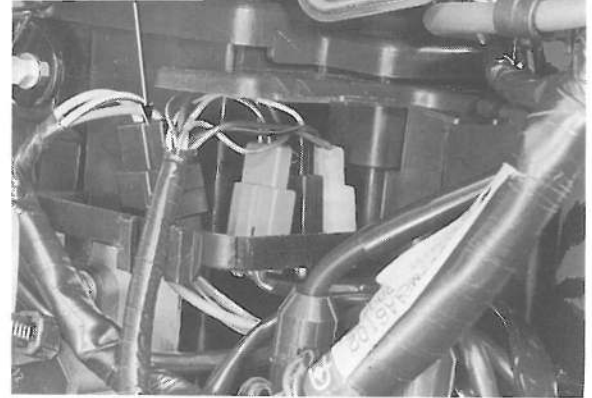

FAN MOTOR SWITCH

INSPECTION

FAN MOTOR DOES NOT STOP

Turn the ignition switch OFF, disconnect the fan motor switch connector from the fan motor switch and turn the ignition switch ON again.

If the fan motor does not stop, check for a shorted wire between the fan motor and switch.

If the fan motor stops, replace the fan motor switch.

FAN MOTOR DOES NOT START

Before testing, warm up the engine to operating temperature.

Disconnect the connector from the fan motor switch and ground the connector to the body with a jumper wire.

Turn the ignition switch ON and check the fan motor. If the motor starts, check the connection at the fan motor switch terminal. If it is OK, replace the fan motor switch.

If the motor does not start, check for voltage between the fan motor switch connector and ground.

- Battery voltage: Faulty fan motor
- No battery voltage:
 - Broken wire harness
 - Blown sub-fuse
 - Faulty ignition switch
 - Poor connection of the connector (between the ignition switch and fuse box)

REMOVAL/INSTALLATION

Remove the radiator (page 6-9).

Disconnect the fan motor switch connector from the fan motor switch.

Remove the fan motor switch and O-ring from the radiator.

Install the new O-ring.

Clean and apply sealant to the fan motor switch threads.

Install and tighten the fan motor switch to the specified torque.

TORQUE: 18 N·m (1.8 kgf·m, 13 lbf·ft)

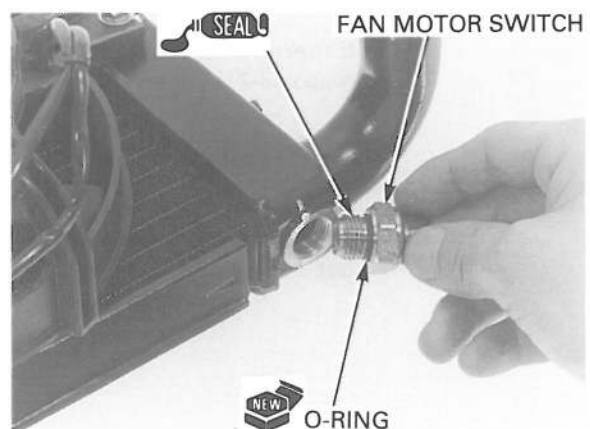
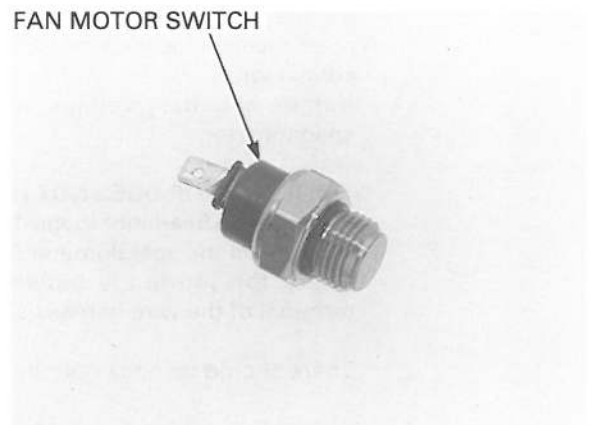
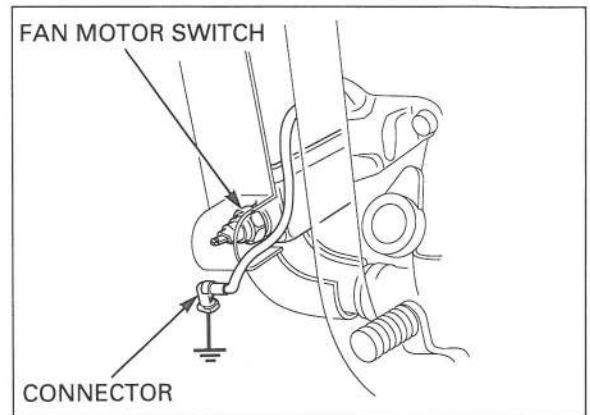
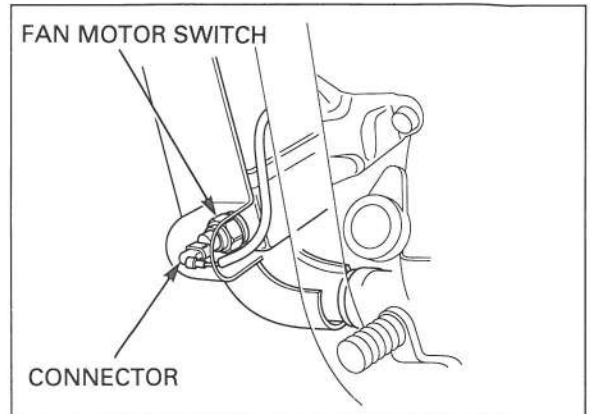

COOLANT TEMPERATURE, THERMO SWITCH

VT750C and
VT750CD/CD2
(*98 - 2000) :

SYSTEM INSPECTION

THE INDICATOR DOES NOT COME ON

Lower the side stand.
Turn the ignition switch ON. The side stand indicator and oil pressure indicator should come on.

-If the side stand indicator and oil pressure indicator come on:

Remove the left steering cover (page 2-3).

Disconnect the thermo switch connector.
Short it to ground using a jumper wire then turn the ignition switch "ON".

Check for loose or poor connection of Green/Yellow connector and the thermo switch.

-If the side stand indicator and oil pressure indicator do not come on:

Check the sub fuse (15A)
Remove the headlight (page 19-7).

Disconnect the speedometer 6P (Black) connector.
Measure the voltage between the Black/Brown (+) and Green/Blue (-) terminal of the wire harness side.

There should be voltage with the ignition switch ON. If there is no voltage, check the wire harness for an open circuit or loose connections in the speedometer connector.

If there is battery voltage available, replace the speedometer.

THE INDICATOR DOES NOT GO OFF

Remove the headlight (page 19-7).
Disconnect the speedometer 6P (Black) connector.
Check for continuity between the Green/Blue terminal of the wire harness side and ground.

There should be no continuity.

If there is continuity, check for a short circuit in the Green/Blue wire.

If there is no continuity, check the thermo switch (page 19-21).

SYSTEM INSPECTION

VT750C3/CD3 and
VT750CD/CD2
(after 2000) :

Turn the ignition switch ON. The temperature warning light should come on for a few seconds and then go out.

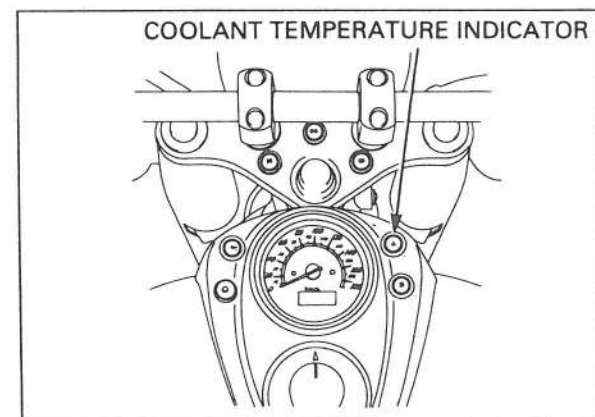
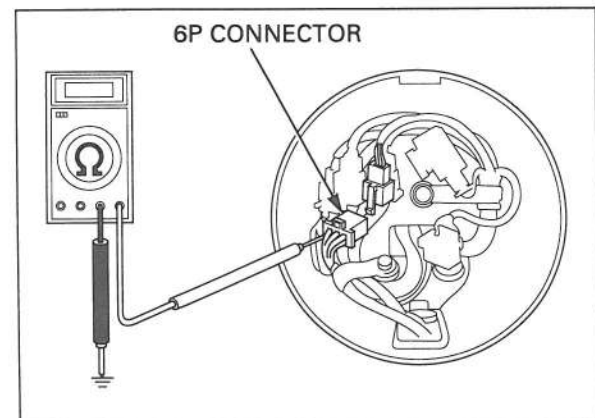
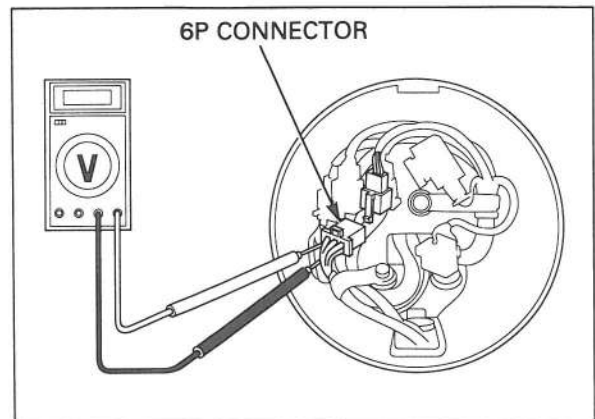
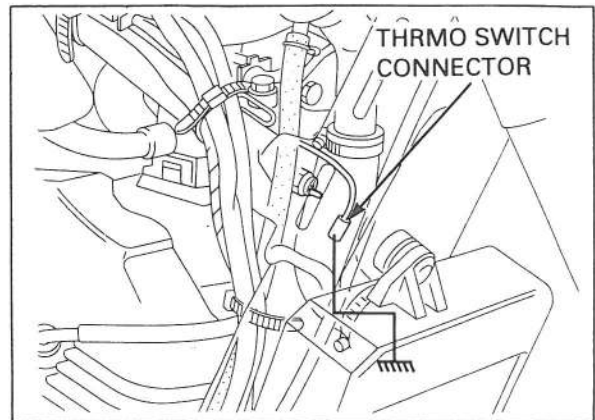

THE INDICATOR DOES NOT GO OFF

Remove the right side cover (page 2-4).

Disconnect the pilot lamp checker connector and ignition switch ON.

Check for coolant temperature indicator illuminates. If the coolant temperature indicator illuminates, check for a short circuit in the pilot lamp checker connector Green/Blue terminal.

If the circuit is normal, replace the thermo switch.

If the coolant temperature indicator does not come on, connect the pilot lamp checker connector and ignition switch ON.

Check that the coolant temperature indicator illuminates.

- If the indicators does not go off:
 - Faulty pilot lamp checker
- If the indicators should come on for few seconds, then go off:
 - Faulty thermo switch

THE INDICATOR DOES NOT ILLUMINATE

Remove the right side cover (page 2-4).

Disconnect the pilot lamp checker connector, check for continuity between the Green/Blue wire and ground.

Check that the coolant temperature indicator illuminates.

If the coolant temperature indicator does not illuminates, check for an open circuit in Green/Blue wire.

If the circuit is normal, replace the coolant temperature indicator bulb.

If the coolant temperature indicator illuminates, measure the battery voltage between the pilot lamp checker connector Black/Brown and Green terminal.

- If there is battery voltage:
 - Faulty pilot lamp checker
- If there is no voltage:
 - Open circuit or loose connection in Black/Brown wire

THERMO SWITCH INSPECTION

⚠ WARNING

- *Wear insulated gloves and adequate eye protection.*
- *Keep flammable materials away from the electric heating element.*

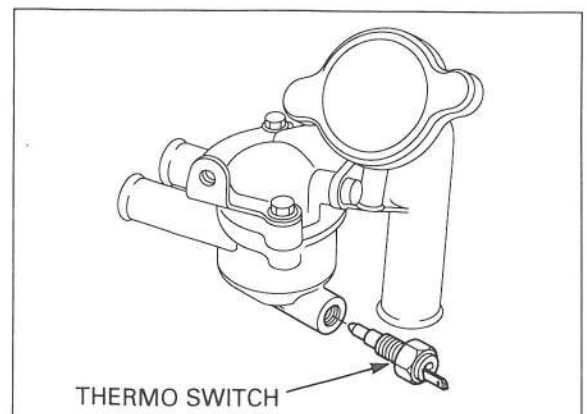
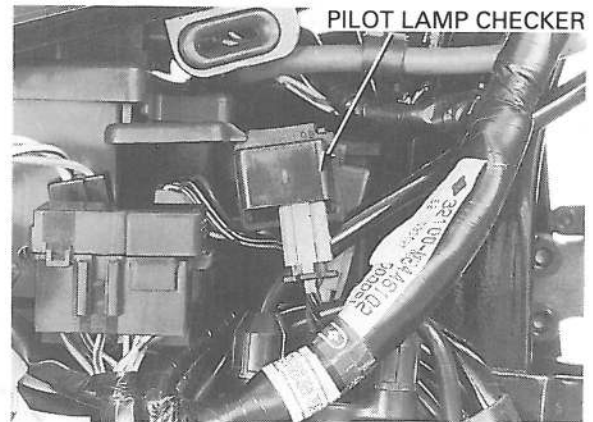

LIGHTS/METERS/SWITCHES

CAUTION:

Do not drop or give strong shock on the thermo switch. Damage to the switch can result.

NOTE:

- The thermo switch is a precision device and can be damaged easily. Before reinstalling an old switch, check that it is not damaged and in good condition.
- Soak the thermo switch in coolant up to its threads with at least a 40 mm (1.6 in) gap from the bottom of the pan to the bottom of the switch.
- Keep the temperature constant for 3 minutes before testing. A sudden change of temperature will result in incorrect readings. Do not let the thermo switch or thermometer touch the pan.

Drain the coolant (page 6-5).
Remove the left steering cover (page 2-3).

Disconnect the thermo switch connector.
Remove the thermo switch.
Suspend the thermo switch in a pan of coolant (50 - 50 mixture) over the electric heating element and check for continuity through the switch as the coolant heats up.

STANDARD:

Starts to close (ON) : 112 – 118°C (259 – 270°F)

Starts to open (OFF) : Below 108°C (252°F)

Replace the switch if it is out of specification.

Clean and apply sealant to the thermo switch threads.
Do not apply sealant to the switch head.

Install and tighten the thermo switch to the specified torque.

TORQUE: 12 N·m (1.2 kgf·m, 9 lbf·ft)

Connect the thermo switch connector.

Refill the coolant (page 6-6).
Install the left steering cover (page 2-3).

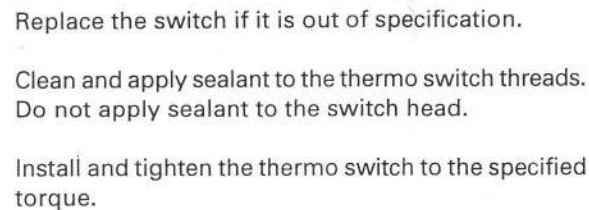
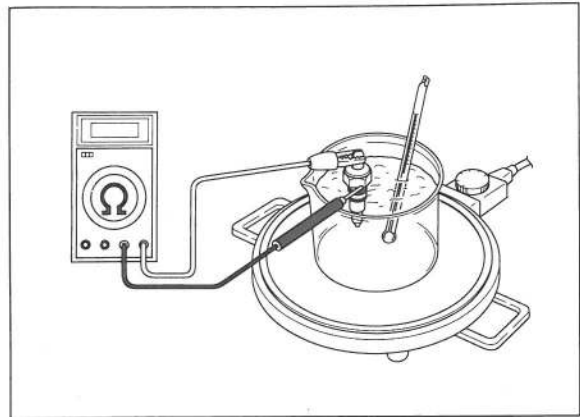

HORN

Remove the nut.
Disconnect the horn connectors and remove the horn.

Connect a 12 V battery to the horn terminals.

The horn is normal if it sounds when the 12 V battery is connected across the horn terminals.

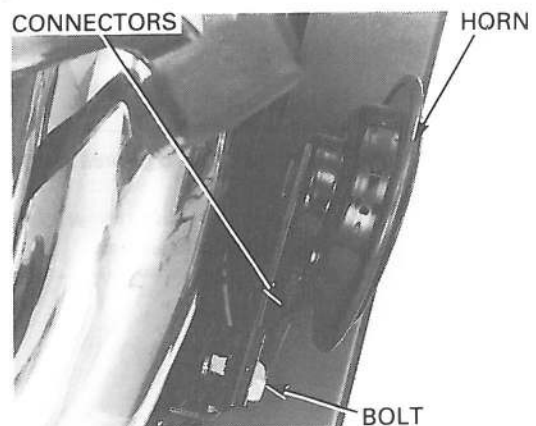

TURN SIGNAL RELAY

REMOVAL/INSTALLATION

Remove the headlight (page 19-7).

Disconnect the turn signal relay 3P connector.
Remove the turn signal relay.

Installation is in the reverse order of removal.

PERFORMANCE TEST

Check the turn signal circuit connection before testing.

Short the Black and Gray terminals of the turn signal relay connector with a jumper wire. Turn the ignition switch ON and check the turn signal light by turning the turn signal switch ON.

If the light does not come on, check the turn signal switch for an open circuit in Black or Gray wire.

If the light comes on, check for continuity between Green terminal and body ground at the turn signal relay 3P (Black) connector.

- No continuity: Open circuit in Green wire
- Continuity:
 - Loose or poor contact of the turn signal relay 3P connector
 - Faulty turn signal relay

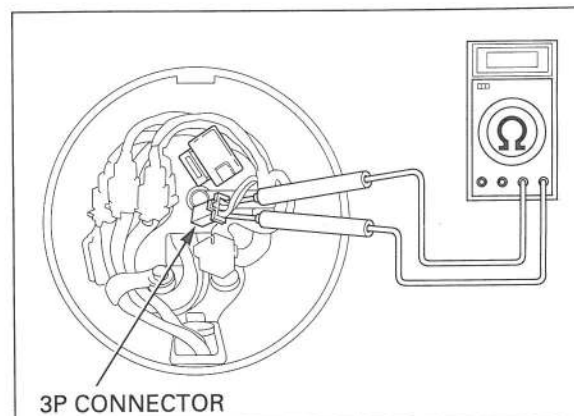
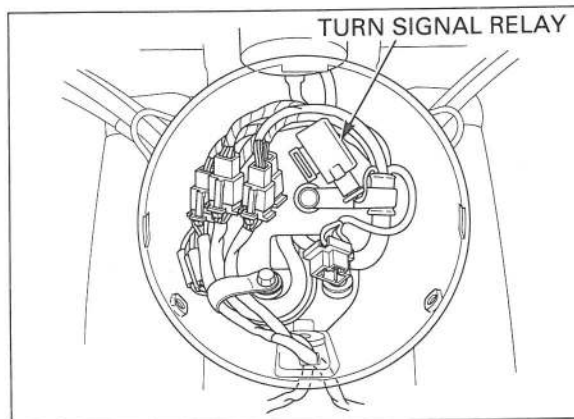

SIDE STAND SWITCH

INSPECTION

Remove the right side cover (page 2-4).

Disconnect the side stand switch 3P (Green) connector.

Check for continuity between each of the terminals as below.

There should be continuity between the ○—○ positions on the chart below.

SIDE STAND SWITCH

	G/W	Y/BI	G
Side stand down		○—○	
Side stand up	○—○		

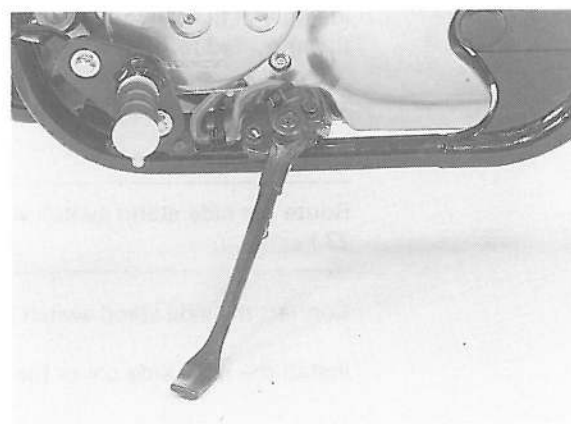
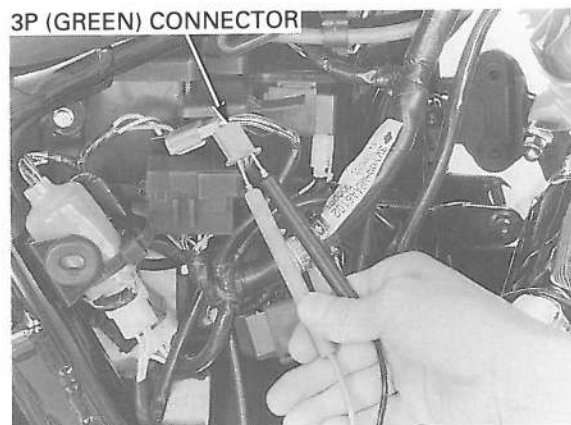

LIGHTS/METERS/SWITCHES

REMOVAL

Remove the right side cover (page 2-4).

Disconnect the side stand 3P (Green) connector.

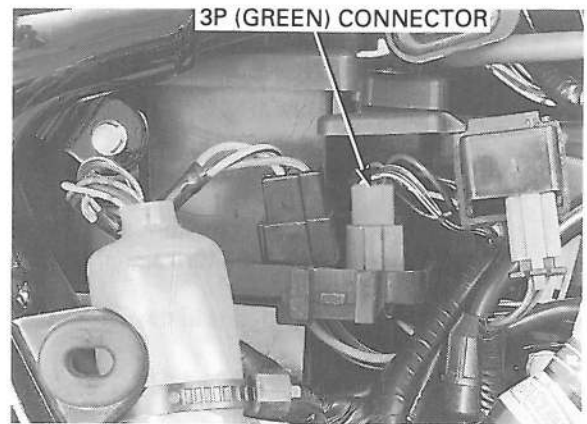

Remove the side stand switch bolt and side stand switch.

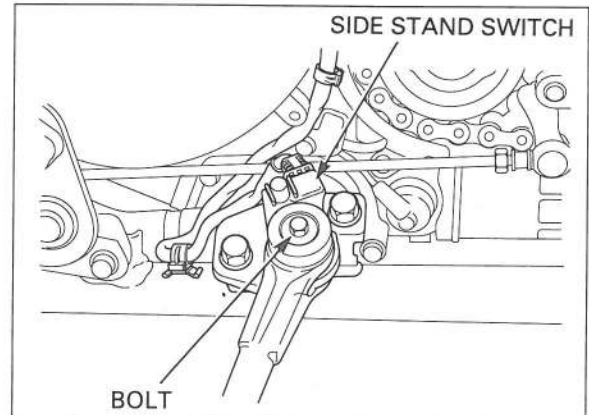

INSTALLATION

Install the side stand switch.

NOTE:

- During side stand switch installation, align the pin on the switch with the hole in the side stand.
- During side stand switch installation, align the groove on the switch with the pin on the side stand bracket.

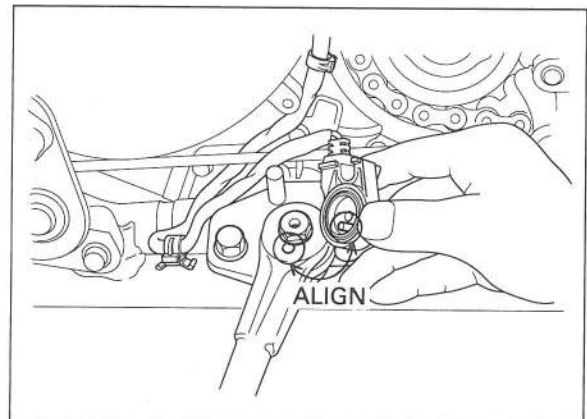

Install and tighten the new side stand switch bolt to the specified torque.

TORQUE: 10 N·m (1.0 kgf·m, 7 lbf·ft)

NOTE:

Route the side stand switch wire properly (page 1-27).

Connect the side stand switch 3P (Green) connector.

Install the right side cover (page 2-4).

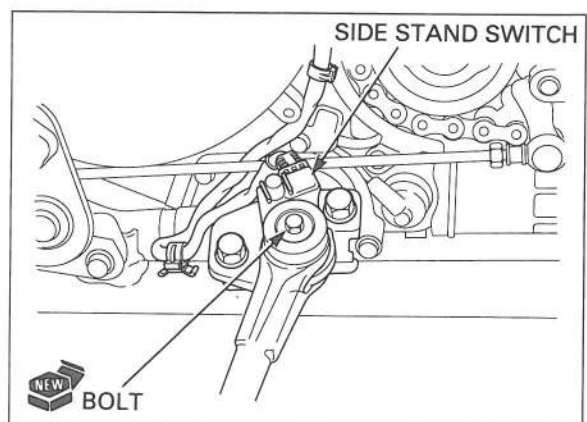

20. WIRING DIAGRAM

VT750C :
VT750CD/CD2 ('98 - 2000) :

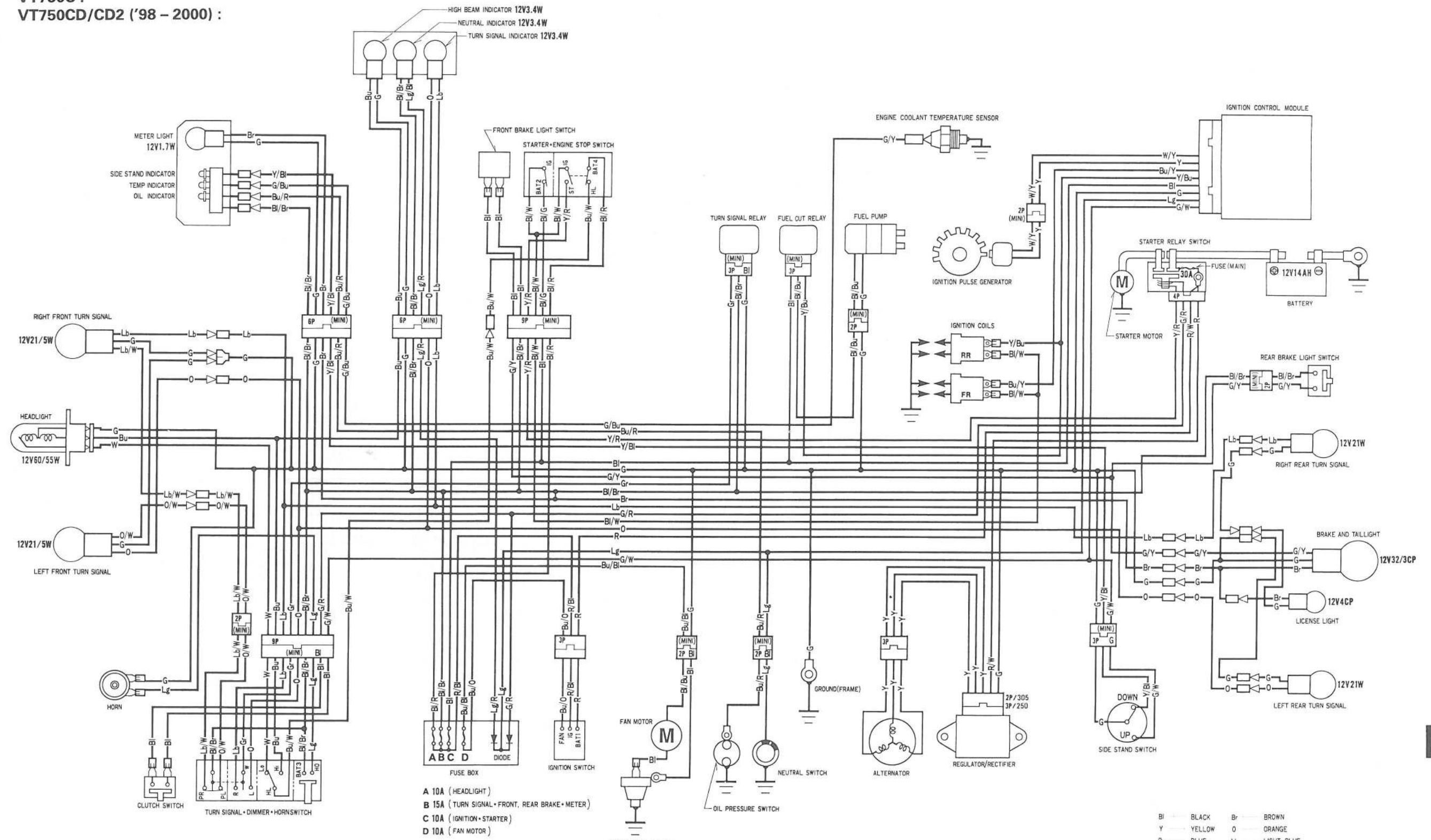

- A 10A (HEADLIGHT)
- B 15A (TURN SIGNAL • FRONT, REAR BRAKE • METER)
- C 10A (IGNITION • STARTER)
- D 10A (FAN MOTOR)

- Bl — BLACK
- Y — YELLOW
- Bu — BLUE
- G — GREEN
- R — RED
- W — WHITE
- Br — BROWN
- O — ORANGE
- Lb — LIGHT BLUE
- Lg — LIGHT GREEN
- P — PINK
- Gr — GRAY

SWITCH CONTINUITY

IGNITION SWITCH			TURN SIGNAL SWITCH						DIMMER SWITCH			HORN SWITCH		ENGINE STOP SWITCH			STARTER SWITCH						
	FAN	IG	BAT1	W	R	L	BAT3	PR	PL	Lo	Lo	Hi	HO	BAT3	OFF	IG	BAT2	FREE	ST	IG	BAT4	HL	
ON	○	○	○	○	○	○	○	○	○	○	○	○	○	○	○	○	○	○	○	○	○	○	○
OFF	○	○	○	○	○	○	○	○	○	○	○	○	○	○	○	○	○	○	○	○	○	○	○

WIRING DIAGRAM

VT750CD/CD2 (After 2000) :
VT750C3/CD3:

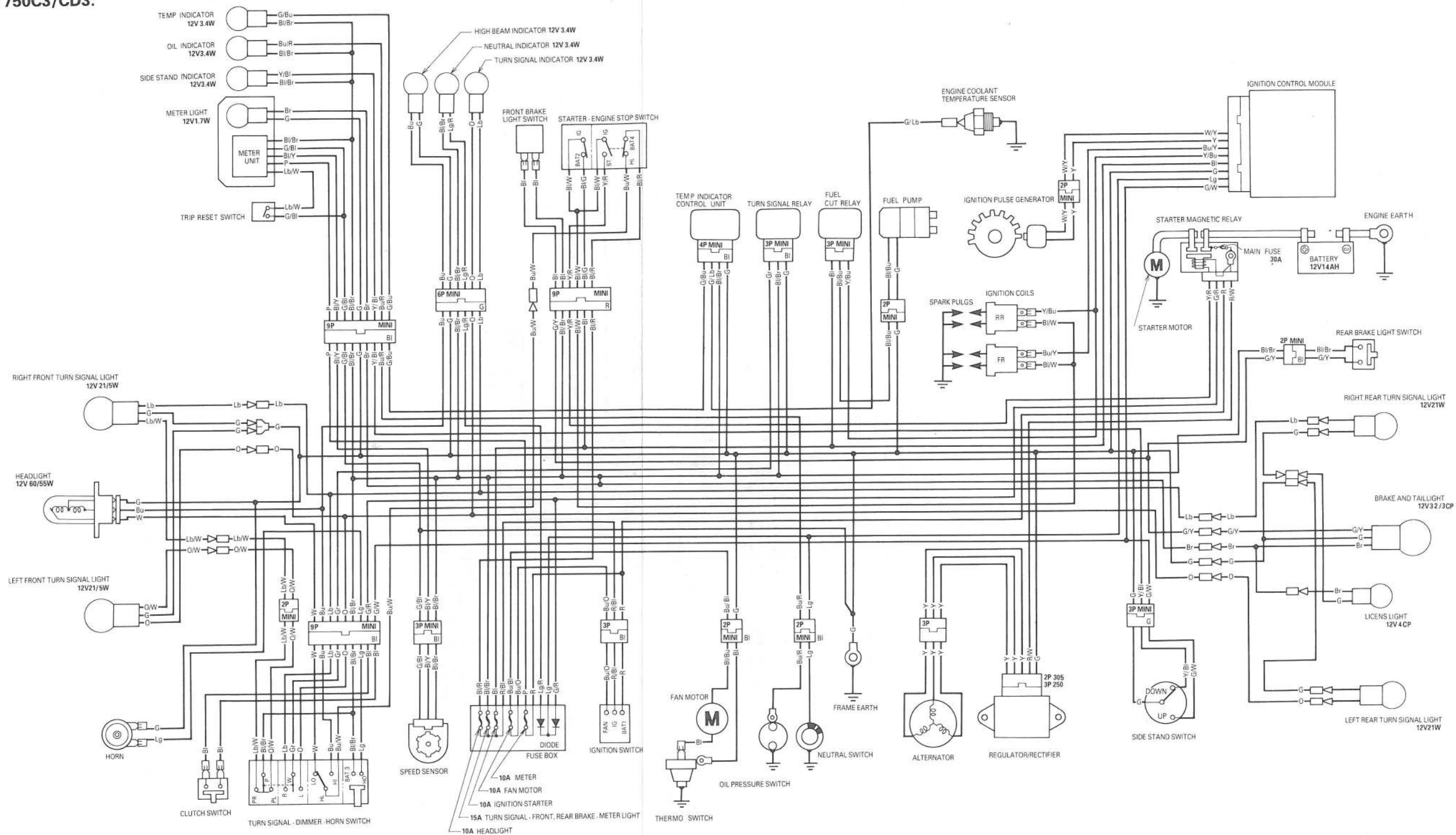

SWITCH CONTINUITY

IGNITION SWITCH	
	FAN IG BAT1
ON	○ ○ ○
OFF	

TURN SIGNAL SWITCH						
	W	R	L	BAT3	PR	PL
R	○	○			○	○
N					○	○
L	○		○		○	○

DIMMER SWITCH			
	HL	LO	HI
LO	○	○	
INI			
HI	○		

HORN SWITCH	
	HO BAT3
FREE	
PUSH	○

ENGINE STOP SWITCH	
	IG BAT2
OFF	
RUN	○

STARTER SWITCH				
	ST	IG	BAT4	HL
FREE				
PUSH	○			

- Bl ---- BLACK
- Y ---- YELLOW
- Bu ---- BLUE
- G ---- GREEN
- R ---- RED
- W ---- WHITE
- Br ---- BROWN
- O ---- ORANGE
- Lb ---- LIGHT BLUE
- Lg ---- LIGHT GREEN
- P ---- PINK
- Gr ---- GRAY

0030Z-MBA-7100

21. TROUBLESHOOTING

ENGINE DOES NOT START OR IS HARD TO START	21-1	POOR PERFORMANCE AT HIGH SPEED	21-4
ENGINE LACKS POWER	21-2	POOR HANDLING	21-4
POOR PERFORMANCE AT LOW AND IDLE SPEED	21-3		

ENGINE DOES NOT START OR IS HARD TO START

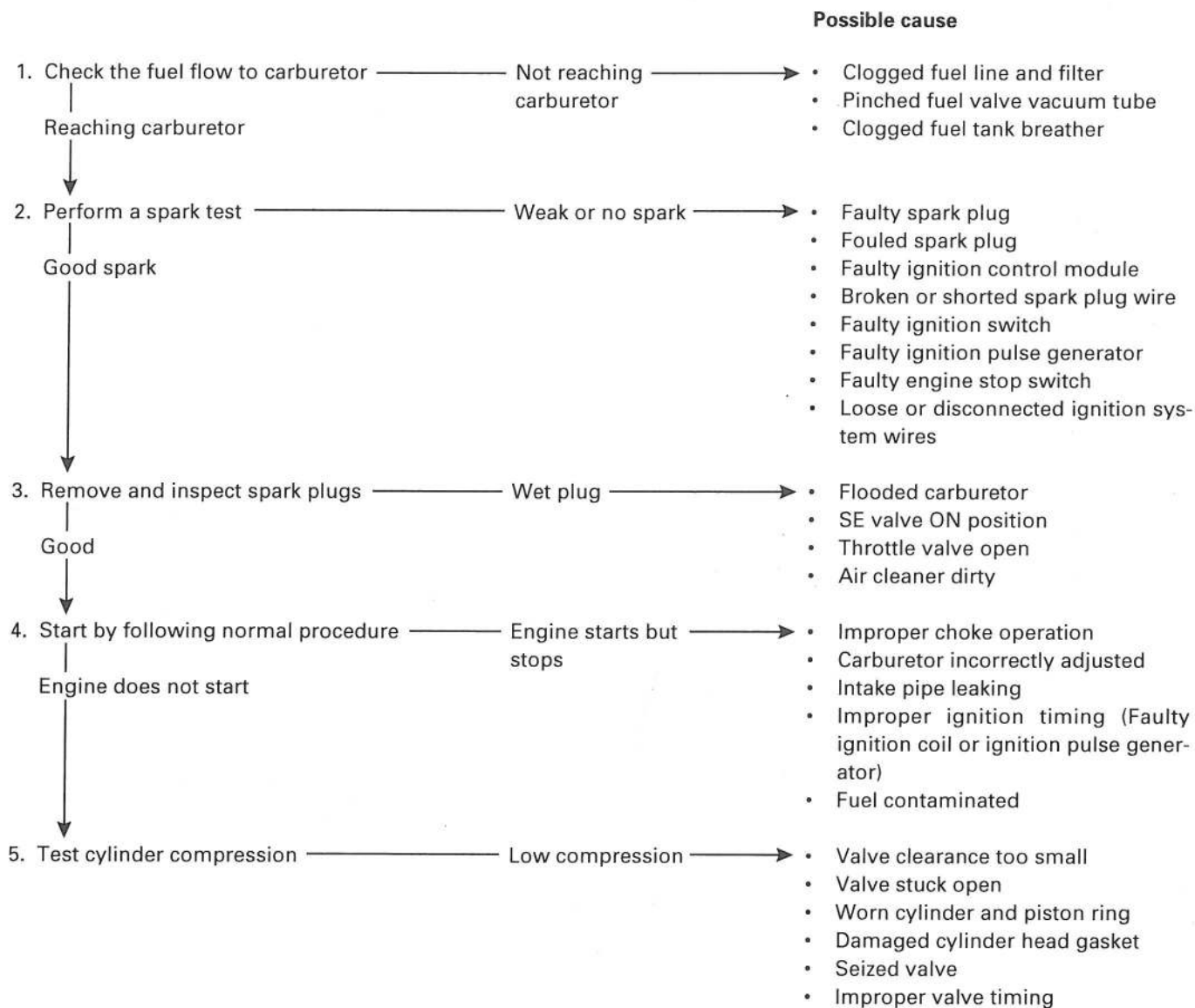

TROUBLESHOOTING

ENGINE LACKS POWER

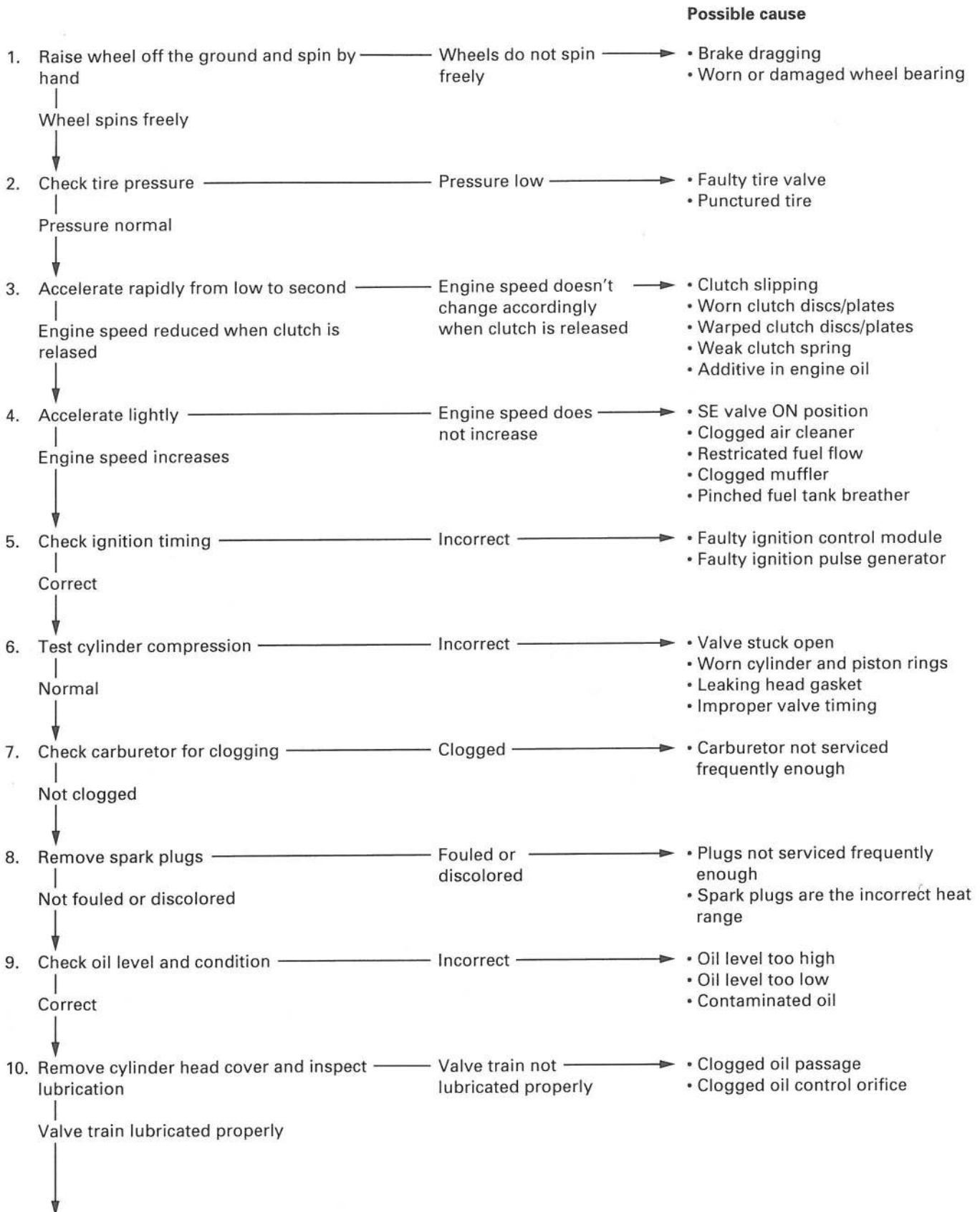

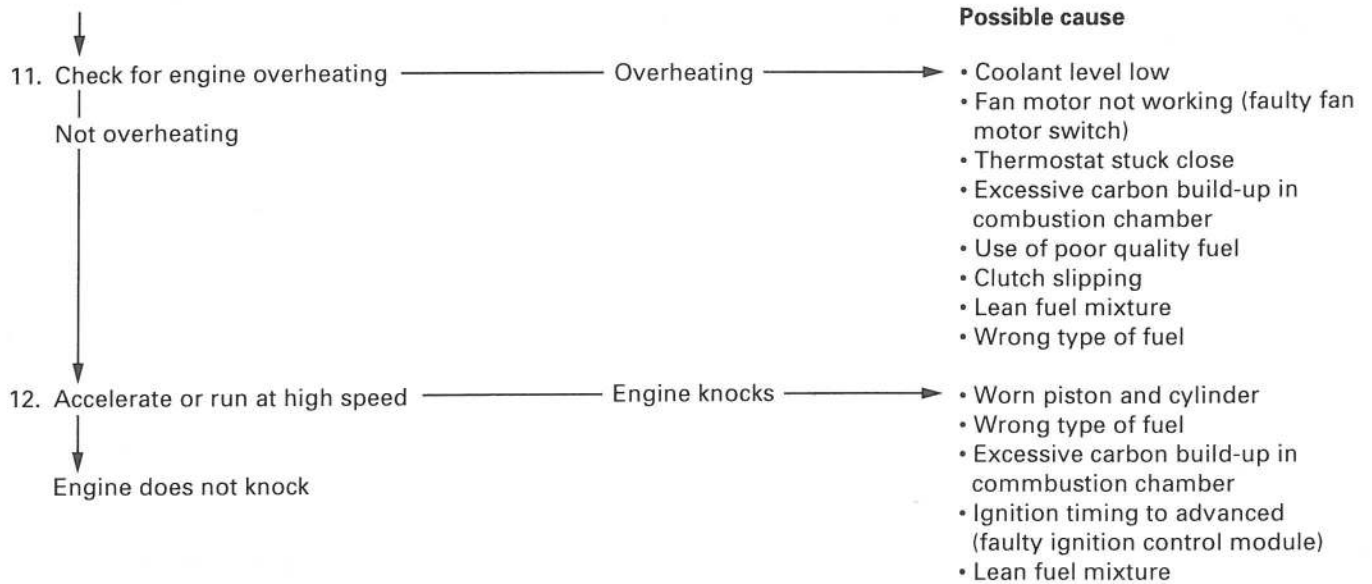

POOR PERFORMANCE AT LOW AND IDLE SPEED

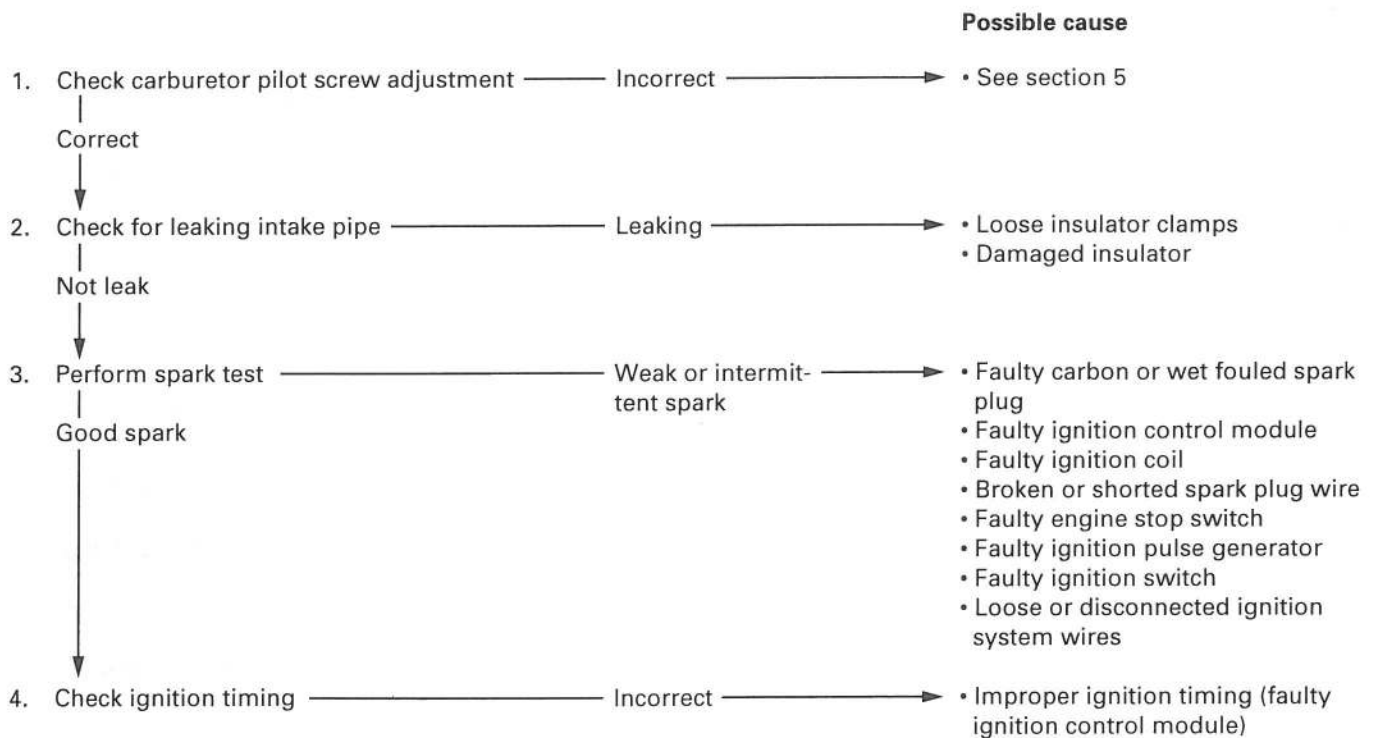

TROUBLESHOOTING

POOR PERFORMAMCE AT HIGH SPEED

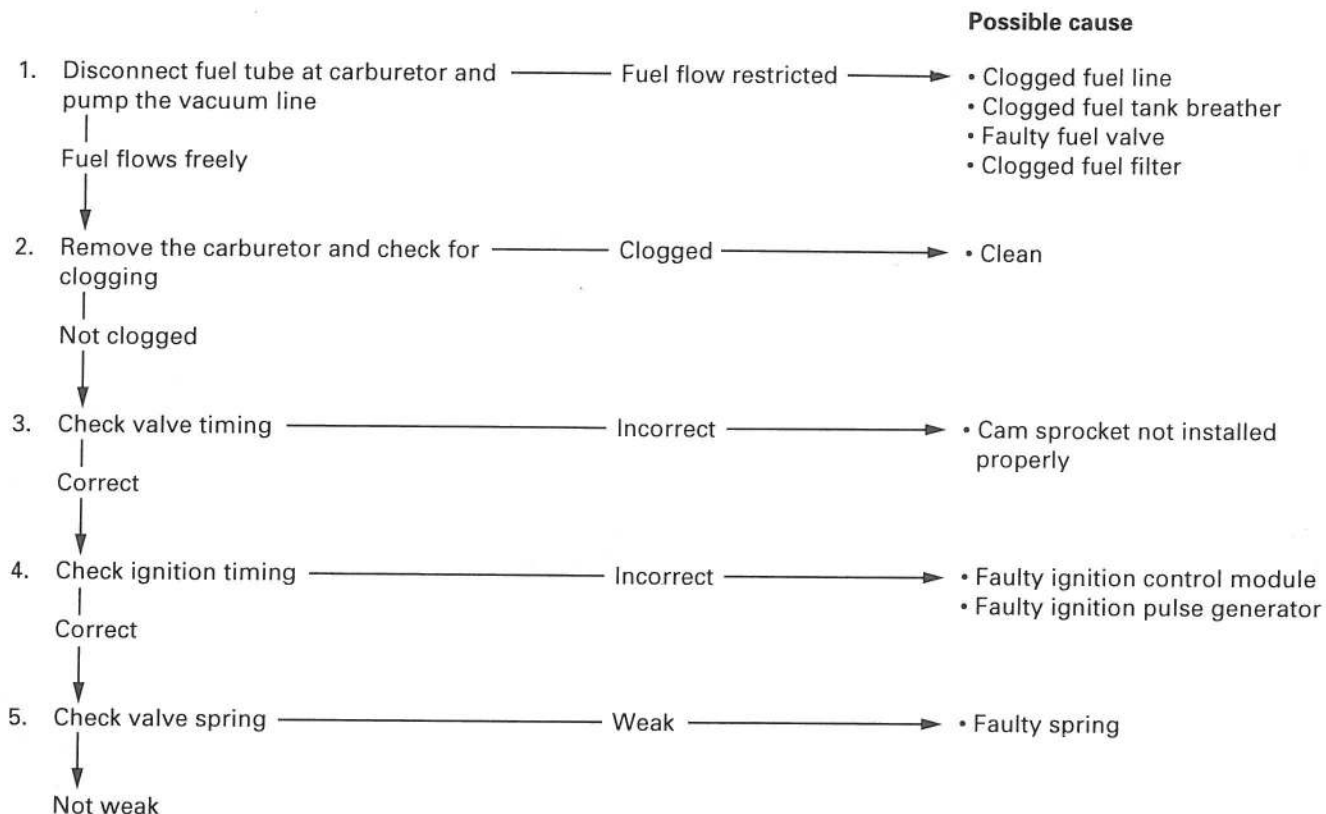

POOR HANDLING

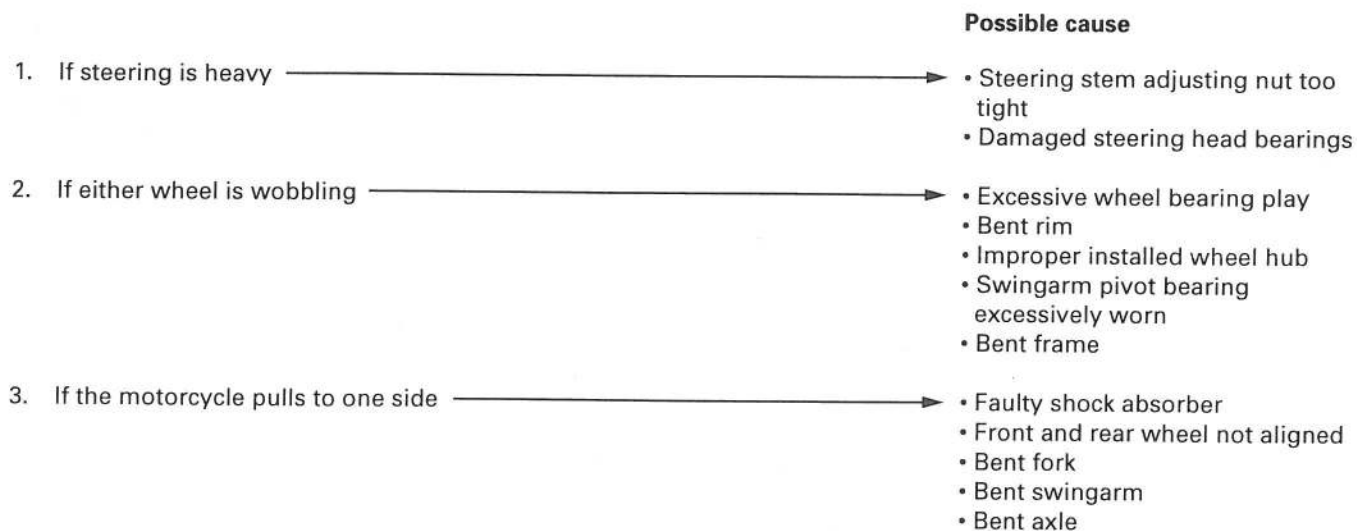

AIR CLEANER	3-6	ENGINE REMOVAL	7-5
AIR CLEANER CHAMBER	5-6	EVAPORATIVE EMISSION CARBURETOR AIR	
AIR CLEANER HOUSING	5-4	VENT CONTROL VALVE INSPECTION	
AIR CUT-OFF VALVE	5-17	(CALIFORNIA TYPE ONLY)	5-30
BATTERY	16-5	EVAPORATIVE EMISSION PURGE CONTROL	
BRAKE CALIPER	15-13	VALVE INSPECTION (CALIFORNIA TYPE ONLY)	5-28
BRAKE FLUID	3-22	EXHAUST PIPE/MUFFLER	2-7
BRAKE FLUID REPLACEMENT/AIR BLEEDING	15-3	FAN MOTOR SWITCH	19-19
BRAKE LIGHT SWITCH	3-25	FLOAT CHAMBER	5-13
BRAKE PAD/DISC	15-5	FLYWHEEL, STARTER CLUTCH	9-3
BRAKE PEDAL	14-15	FORK	13-22
BRAKE SHOE/PAD WEAR	3-23	FRONT BRAKE LIGHT SWITCH	19-16
BRAKE SYSTEM	3-23	FRONT WHEEL	13-13
BULB REPLACEMENT	19-7	FUEL FILTER	5-26
CABLE & HARNESS ROUTING	1-22	FUEL LINE	3-4
CAMSHAFT INSTALLATION	10-26	FUEL PUMP	5-24
CAMSHAFT REMOVAL	10-8	FUEL TANK	2-4
CARBURETOR BODY CLEANING	5-17	GEARSHIFT LINKAGE	8-12
CARBURETOR CHOKE	3-5	GENERAL SAFETY	1-1
CARBURETOR DISASSEMBLY/ASSEMBLY	5-10	GRAB RAIL	2-6
CARBURETOR INSTALLATION	5-21	HANDLEBAR	13-5
CARBURETOR REASSEMBLY	5-19	HANDLEBAR SWITCH	19-17
CARBURETOR REMOVAL	5-8	HEADLIGHT AIM	3-26
CARBURETOR SEPARATION	5-18	HORN	19-22
CARBURETOR SYNCHRONIZATION	3-14	IGNITION COIL	17-7
CHARGING SYSTEM INSPECTION	16-7	IGNITION CONTROL MODULE (ICM)	17-7
CLUTCH DIODE	18-14	IGNITION SWITCH	19-18
CLUTCH INSTALLATION	8-17	IGNITION SYSTEM INSPECTION	17-4
CLUTCH REMOVAL	8-4	IGNITION TIMING	17-8
CLUTCH SWITCH	19-17	LUBRICATION & SEAL POINTS	1-19
CLUTCH SYSTEM	3-26	MAINTENANCE SCHEDULE	3-3
COOLANT	6-4	MASTER CYLINDER	15-7
COOLANT TEMPERATURE, THERMO SWITCH	19-20	MODEL IDENTIFICATION	1-3
COOLING SYSTEM	3-16	NEUTRAL SWITCH	19-15
CRANKCASE ASSEMBLY	12-22	NUTS, BOLTS, FASTENERS	3-28
CRANKCASE BEARING REPLACEMENT	12-20	OIL PRESSURE CHECK	4-3
CRANKCASE BREATHER	3-7	OIL PRESSURE SWITCH	19-14
CRANKCASE SEPARATION	12-4	OIL PUMP	4-4
CRANKCASE STUD BOLT INSPECTION	11-8	PILOT SCREW ADJUSTMENT	5-22
CRANKSHAFT/CONNECTING ROD	12-6	PISTON INSTALLATION	11-8
CYLINDER COMPRESSION	10-4	PISTON REMOVAL	11-5
CYLINDER HEAD ASSEMBLY	10-22	POOR HANDLING	21-4
CYLINDER HEAD COVER INSTALLATION	10-32	POOR PERFORMANCE AT HIGH SPEED	21-4
CYLINDER HEAD COVER REMOVAL	10-5	POOR PERFORMANCE AT LOW AND IDLE SPEED	21-3
CYLINDER HEAD DISASSEMBLY	10-15	PRIMARY DRIVE GEAR	8-10
CYLINDER HEAD INSTALLATION	10-24	RADIATOR COOLANT	3-16
CYLINDER HEAD REMOVAL	10-14	RADIATOR RESERVE TANK	6-18
CYLINDER INSTALLATION	11-10	RADIATOR/COOLING FAN	6-9
CYLINDER REMOVAL	11-3	REAR BRAKE	14-11
DRIVE CHAIN	3-18	REAR BRAKE LIGHT SWITCH	19-16
DRIVE CHAIN SLIDER	3-22	REAR FENDER	2-6
DRIVE SPROCKET INSTALLATION	7-13	REAR WHEEL	14-3
DRIVE SPROCKET REMOVAL	7-3	REGULATOR/RECTIFIER	16-9
EMISSION CONTROL INFORMATION LABELS	1-36	RIGHT CRANKCASE COVER INSTALLATION	8-21
EMISSION CONTROL SYSTEMS	1-34	RIGHT CRANKCASE COVER REMOVAL	8-3
ENGINE DOES NOT START OR IS		SEAT	2-2
HARD TO START	21-1	SERVICE INFORMATION	
ENGINE IDLE SPEED	3-15	(ALTERNATOR/STARTER CLUTCH)	9-1
ENGINE INSTALLATION	7-9	(BATTERY/CHARGING SYSTEM)	16-1
ENGINE LACKS POWER	21-2	(CLUTCH/GEARSHIFT LINKAGE)	8-1
ENGINE OIL/OIL FILTER	3-11	(COOLING SYSTEM)	6-1

INDEX

SERVICE INFORMATION		(LIGHT/METERS/SWITCHES)	19-4
(CRANKSHAFT/TRANSMISSION)	12-2	(LUBRICATION SYSTEM)	4-2
(CYLINDER HEAD/VALVES)	10-1	(REAR WHEEL/BRAKE/SUSPENSION)	14-2
(CYLINDER/PISTON)	11-1	TURN SIGNAL RELAY	19-23
(ENGINE REMOVAL/INSTALLATION)	7-2	VACUUM CHAMBER	5-11
(ELECTRIC STARTER)	18-1	VALVE CLEARANCE	3-9
(FRAME/BODY PANELS/EXHAUST SYSTEM)	2-1	VALVE GUIDE REPLACEMENT	10-18
(FRONT WHEEL/SUSPENSION/STEERING)	13-2	VALVE SEAT INSPECTION/REFACING	10-20
(FUEL SYSTEM)	5-1	WATER PUMP	6-15
(HYDRAULIC BRAKE)	15-1	WHEELS/TIRES	3-28
(IGNITION SYSTEM)	17-1		
(LIGHTS/METERS/SWITCHES)	19-2		
(LUBRICATION SYSTEM)	4-1		
(MAINTENANCE)	3-1		
(REAR WHEEL/BRAKE/SUSPENSION)	14-1		
SERVICE RULES	1-2		
SHOCK ABSORBER	14-18		
SIDE COVER	2-4		
SIDE STAND	3-27		
SIDE STAND SWITCH	19-23		
SPARK PLUG	3-7		
SPECIFICATIONS	1-4		
SPEEDOMETER	19-10		
SPEED SENSOR (VT750CD (AFTER '00), VT750CD2/C3/CD3)	19-13		
STARTER MOTOR	18-4		
STARTER RELAY SWITCH	18-13		
STATOR INSTALLATION	9-9		
STATOR REMOVAL	9-2		
STEERING COVER	2-3		
STEERING HEAD BEARINGS	3-29		
STEERING STEM	13-34		
SUB-AIR CLEANER ELEMENT	5-5		
SUSPENSION	3-27		
SWINGARM	14-19		
SYSTEM DIAGRAM			
(BATTERY/CHARGING SYSTEM)	16-0		
(ELECTRIC STARTER)	18-0		
(IGNITION SYSTEM)	17-0		
(LIGHTS/METERS/SWITCHES)	19-0		
SYSTEM TESTING	6-3		
THERMOSTAT	6-6		
THROTTLE OPERATION	3-4		
TOOLS	1-17		
TORQUE VALUES	1-13		
TRANSMISSION	12-12		
TROUBLESHOOTING	10-3		
(ALTERNATOR/STARTER CLUTCH)	9-1		
(BATTERY/CHARGING SYSTEM)	16-3		
(CLUTCH/GEARSHIFT LINKAGE)	8-2		
(COOLING SYSTEM)	6-2		
(CRANKSHAFT/TRANSMISSION)	12-3		
(CYLINDER HEAD/VALVES)	10-3		
(CYLINDER/PISTON)	11-2		
(ELECTRIC STARTER)	18-2		
(FRAME/BODY PANELS/EXHAUST SYSTEM)	2-1		
(FRONT WHEEL/SUSPENSION/STEERING)	13-4		
(FUEL SYSTEM)	5-3		
(HYDRAULIC BRAKE)	15-2		
(IGNITION SYSTEM)	17-3		